

**ASME B30.13-2017**  
(Revision of ASME B30.13-2011)

# **Storage/Retrieval (S/R) Machines and Associated Equipment**

---

**Safety Standard for Cableways,  
Cranes, Derricks, Hoists, Hooks, Jacks,  
and Slings**

**AN AMERICAN NATIONAL STANDARD**



**The American Society of  
Mechanical Engineers**

**ASME B30.13-2017**  
(Revision of ASME B30.13-2011)

# **Storage/Retrieval (S/R) Machines and Associated Equipment**

---

**Safety Standard for Cableways,  
Cranes, Derricks, Hoists, Hooks, Jacks,  
and Slings**

**AN AMERICAN NATIONAL STANDARD**



**The American Society of  
Mechanical Engineers**

Two Park Avenue • New York, NY • 10016 USA

Date of Issuance: October 20, 2017

The next edition of this Standard is scheduled for publication in 2022. This Standard will become effective 1 year after the Date of Issuance.

ASME issues written replies to inquiries concerning interpretations of technical aspects of this Standard. Interpretations are published on the ASME Web site under the Committee Pages at <http://cstools.asme.org/> as they are issued.

Errata to codes and standards may be posted on the ASME Web site under the Committee Pages to provide corrections to incorrectly published items, or to correct typographical or grammatical errors in codes and standards. Such errata shall be used on the date posted.

The Committee Pages can be found at <http://cstools.asme.org/>. There is an option available to automatically receive an e-mail notification when errata are posted to a particular code or standard. This option can be found on the appropriate Committee Page after selecting “Errata” in the “Publication Information” section.

ASME is the registered trademark of The American Society of Mechanical Engineers.

This code or standard was developed under procedures accredited as meeting the criteria for American National Standards. The Standards Committee that approved the code or standard was balanced to assure that individuals from competent and concerned interests have had an opportunity to participate. The proposed code or standard was made available for public review and comment that provides an opportunity for additional public input from industry, academia, regulatory agencies, and the public-at-large.

ASME does not “approve,” “rate,” or “endorse” any item, construction, proprietary device, or activity.

ASME does not take any position with respect to the validity of any patent rights asserted in connection with any items mentioned in this document, and does not undertake to insure anyone utilizing a standard against liability for infringement of any applicable letters patent, nor assume any such liability. Users of a code or standard are expressly advised that determination of the validity of any such patent rights, and the risk of infringement of such rights, is entirely their own responsibility.

Participation by federal agency representative(s) or person(s) affiliated with industry is not to be interpreted as government or industry endorsement of this code or standard.

ASME accepts responsibility for only those interpretations of this document issued in accordance with the established ASME procedures and policies, which precludes the issuance of interpretations by individuals.

No part of this document may be reproduced in any form,  
in an electronic retrieval system or otherwise,  
without the prior written permission of the publisher.

The American Society of Mechanical Engineers  
Two Park Avenue, New York, NY 10016-5990

Copyright © 2017 by  
THE AMERICAN SOCIETY OF MECHANICAL ENGINEERS  
All rights reserved  
Printed in U.S.A.

# CONTENTS

Foreword . . . . .	iv
Committee Roster . . . . .	vi
B30 Standard Introduction . . . . .	viii
Summary of Changes . . . . .	xi
<b>Chapter 13-0</b> <b>Scope, Definitions, References, and Personnel Competence</b> . . . . .	1
Section 13-0.1    Scope of B30.13 . . . . .	1
Section 13-0.2    Definitions . . . . .	1
Section 13-0.3    References to Other Codes and Standards . . . . .	4
Section 13-0.4    Personnel Competence . . . . .	4
<b>Chapter 13-1</b> <b>Construction and Installation</b> . . . . .	5
Section 13-1.1    Signs and Labels . . . . .	5
Section 13-1.2    Clearances . . . . .	5
Section 13-1.3    General Construction . . . . .	5
Section 13-1.4    Cabs . . . . .	6
Section 13-1.5    Lubrication . . . . .	6
Section 13-1.6    Platforms, Ladders, and Personnel Access to Aisles and Runways . . . . .	6
Section 13-1.7    Stops, Bumpers, Interlocks, Sweeps, and Guards . . . . .	7
Section 13-1.8    Brakes . . . . .	7
Section 13-1.9    Electrical Equipment . . . . .	8
Section 13-1.10   Hoisting Equipment . . . . .	11
Section 13-1.11   Technical and Safety-Related Instructions and Manuals . . . . .	12
<b>Chapter 13-2</b> <b>Inspection, Testing, and Maintenance</b> . . . . .	14
Section 13-2.1    Inspection . . . . .	14
Section 13-2.2    Testing . . . . .	15
Section 13-2.3    Maintenance . . . . .	15
Section 13-2.4    Rope Inspection, Replacement, and Maintenance . . . . .	16
Section 13-2.5    Roller Chain and Leaf Chain Inspection, Replacement, and Maintenance . . . . .	17
Section 13-2.6    Welded Link Chain Inspection, Replacement, and Maintenance . . . . .	18
Section 13-2.7    Belt Inspection and Replacement . . . . .	18
<b>Chapter 13-3</b> <b>Operation.</b>	20
Section 13-3.1    Qualifications for and Conduct of Operators . . . . .	20
Section 13-3.2    Handling the Load . . . . .	21
Section 13-3.3    Miscellaneous . . . . .	21
<b>Figures</b>	
13-0.2.1-1       Typical Unit Load S/R Machine . . . . .	2
13-0.2.1-2       Typical Aisle Transfer Car . . . . .	2
13-0.2.1-3       Typical Operator Ridden S/R Machine . . . . .	3

## FOREWORD

This American National Standard, Safety Standard for Cableways, Cranes, Derricks, Hoists, Hooks, Jacks, and Slings, has been developed under the procedures accredited by the American National Standards Institute (ANSI). This Standard had its beginning in December 1916 when an eight-page Code of Safety Standards for Cranes, prepared by an ASME Committee on the Protection of Industrial Workers, was presented to the annual meeting of the ASME.

Meetings and discussions regarding safety on cranes, derricks, and hoists were held from 1920 to 1925, involving the ASME Safety Code Correlating Committee, the Association of Iron and Steel Electrical Engineers, the American Museum of Safety, the American Engineering Standards Committee (AESC) [later changed to American Standards Association (ASA), then to the United States of America Standards Institute (USASI), and finally to ANSI], Department of Labor — State of New Jersey, Department of Labor and Industry — State of Pennsylvania, and the Locomotive Crane Manufacturers Association. On June 11, 1925, AESC approved the ASME Safety Code Correlating Committee's recommendation and authorized the project with the U.S. Department of the Navy, Bureau of Yards and Docks, and ASME as sponsors.

In March 1926, invitations were issued to 50 organizations to appoint representatives to a Sectional Committee. The call for organization of this Sectional Committee was sent out October 2, 1926, and the committee organized November 4, 1926, with 57 members representing 29 national organizations. Commencing June 1, 1927, and using the eight-page code published by ASME in 1916 as a basis, the Sectional Committee developed the Safety Code for Cranes, Derricks, and Hoists. The early drafts of this safety code included requirements for jacks but, due to inputs and comments on those drafts, the Sectional Committee decided in 1938 to make the requirements for jacks a separate code. In January 1943, ASA B30.2-1943 was published addressing a multitude of equipment types, and in August 1943, ASA B30.1-1943 was published just addressing jacks. Both documents were reaffirmed in 1952 and widely accepted as a safety standard.

Due to changes in design, advancement in techniques, and general interest of labor and industry in safety, the Sectional Committee, under the joint sponsorship of ASME and the Bureau of Yards and Docks (now the Naval Facilities Engineering Command), was reorganized on January 31, 1962, with 39 members representing 27 national organizations. The new committee changed the format of ASA B30.2-1943 so that the multitude of equipment types it addressed could be published in separate volumes that could completely cover the construction, installation, inspection, testing, maintenance, and operation of each type of equipment that was included in the scope of ASA B30.2. This format change resulted in the initial publication of B30.3, B30.5, B30.6, B30.11, and B30.16 being designated as revisions of B30.2 with the remainder of the B30 volumes being published as totally new volumes. ASA changed its name to USASI in 1966 and to ANSI in 1969, which resulted in B30 volumes from 1943 to 1968 being designated as ASA B30, USAS B30 or ANSI B30 depending on their date of publication.

In 1982, the Committee was reorganized as an Accredited Organization Committee, operating under procedures developed by ASME and accredited by ANSI. This Standard presents a coordinated set of rules that may serve as a guide to government and other regulatory bodies and municipal authorities responsible for the guarding and inspection of the equipment falling within its scope. The suggestions leading to accident prevention are given both as mandatory and advisory provisions; compliance with both types may be required by employers of their employees.

In case of practical difficulties, new developments, or unnecessary hardship, the administrative or regulatory authority may grant variances from the literal requirements or permit the use of other devices or methods, but only when it is clearly evident that an equivalent degree of protection is thereby secured. To secure uniform application and interpretation of this Standard, administrative or regulatory authorities are urged to consult the B30 Committee, in accordance with the format described in Section IX of the Introduction, before rendering decisions on disputed points.

Safety codes and standards are intended to enhance public safety. Revisions result from committee consideration of factors such as technological advances, new data, and changing environmental and industry needs. Revisions do not imply that previous editions were inadequate.

The first edition of ASME B30.13, entitled Controlled Mechanical Storage Cranes, was published in 1977. New editions were published in 1985, 1991, 1996, 2003, and 2011. In this 2017 edition, revisions were made to reflect current technology and terminology.

This Volume of the Standard, which was approved by the B30 Standard Committee and ASME, was approved by ANSI and designated as an American National Standard on March 20, 2017.

# ASME B30 COMMITTEE

## Safety Standard for Cableways, Cranes, Derricks, Hoists, Hooks, Jacks, and Slings

(The following is the roster of the Committee at the time of approval of this Standard.)

### STANDARDS COMMITTEE OFFICERS

**B. D. Closson**, *Chair*  
**T. L. Blanton**, *Vice Chair*  
**K. M. Hyam**, *Secretary*

### STANDARDS COMMITTEE PERSONNEL

**N. E. Andrew**, LTS Cranes Mechanical  
**M. J. Eggenberger**, *Alternate*, Bery Contracting, Inc.  
**T. L. Blanton**, *Vice Chair*, NACB Group, Inc.  
**P. A. Boeckman**, The Crosby Group, Inc.  
**E. E. Lutter**, *Alternate*, The Crosby Group, Inc.  
**P. W. Boyd**, The Boeing Co.  
**B. B. Bacon**, *Alternate*, Tennessee Valley Authority  
**B. D. Closson**, *Chair*, Craft Forensic Service  
**J. A. Danielson**, The Boeing Co.  
**B. M. Casey**, *Alternate*, General Dynamics Electric Boat  
**D. R. Decker**, Becket, LLC  
**L. D. DeMark, Sr.**, Equipment Training Solutions, LLC  
**D. F. Jordan**, *Alternate*, American International Crane Bureau  
**D. W. Eckstine**, Eckstine & Associates  
**G. J. Brent**, *Alternate*, National Commission for the Certification of Crane Operators  
**R. J. Edwards**, NBIS Claims and Risk Management, Inc.  
**T. Inglese**, *Alternate*, Pioneer Concrete Pumping  
**A. J. Egging**, National Oilwell Varco  
**R. Stanoch**, *Alternate*, IPS Worldwide  
**E. D. Fidler**, The Manitowoc Co.  
**G. D. Miller**, *Alternate*, Manitowoc Cranes  
**J. A. Gilbert**, Associated Wire Rope Fabricators  
**J. L. Gordon**, Acco Material Handling Solutions, Inc.  
**N. C. Hargreaves**, Hargreaves Consulting, LLC  
**G. B. Hetherston**, Consultant  
**R. J. Bolen**, *Alternate*, Consultant  
**K. M. Hyam**, *Secretary*, The American Society of Mechanical Engineers  
**M. M. Jaxheimer**, Navy Crane Center  
**S. R. Gridley**, *Alternate*, Navy Crane Center  
**P. R. Juhren**, Morrow Equipment Co., LLC  
**M. J. Quinn**, *Alternate*, Morrow Equipment Co., LLC  
**R. M. Kohner**, Landmark Engineering Services, Ltd.  
**D. Duerr**, *Alternate*, 2DM Associates, Inc.  
**A. J. Lusi, Jr.**, Lumark Consulting, LLP  
**K. J. Shinn**, *Alternate*, K. J. Shinn, Inc.  
**E. K. Marburg**, Columbus McKinnon Corp.  
**J. R. Burkey**, *Alternate*, Columbus McKinnon Corp.  
**L. D. Means**, Means Engineering & Consulting  
**D. A. Henninger**, *Alternate*, The Ropes Group  
**M. W. Mills**, Liberty Mutual Insurance  
**D. M. Gordon**, *Alternate*, Liberty Mutual Insurance  
**D. L. Morgan**, Critical Lift Consultants, LLC  
**T. C. Mackey**, *Alternate*, WRPS Hanford, an AECOM Co.  
**W. E. Osborn**, Ingersoll Rand  
**S. Snider**, *Alternate*, Ingersoll Rand  
**R. M. Parnell**, Industrial Training International  
**W. C. Dickinson, Jr.**, *Alternate*, Crane Industry Services, LLC  
**J. T. Perkins**, First Solar Electric  
**J. R. Schober**, *Alternate*, American Bridge Co.  
**B. A. Pickett**, Systems Engineering and Forensic Services  
**S. K. Rammelsberg**, Chicago Bridge & Iron Co.  
**J. M. Randall**, *Alternate*, Chicago Bridge & Iron Co.  
**J. E. Richardson**, Navy Crane Center  
**K. Kennedy**, *Alternate*, Navy Crane Center  
**D. W. Ritchie**, David Ritchie Consultant, LLC  
**L. K. Shapiro**, *Alternate*, Howard I. Shapiro & Associates  
**J. W. Rowland III**, Consultant  
**D. A. Moore**, *Alternate*, Unified Engineering  
**J. C. Ryan**, Boh Bros. Construction Co., LLC  
**A. R. Ruud**, *Alternate*, Atkinson Construction  
**D. W. Smith**, STI Group  
**C. Warren**, *Alternate*, Webber  
**W. J. Smith, Jr.**, NBIS Claims and Risk Management, Inc.  
**J. Schoppert**, *Alternate*, NBIS Claims and Risk Management, Inc.  
**R. S. Stemp**, Lampson International, LLC  
**M. P. Zerba**, *Alternate*, Lampson International, LLC  
**R. G. Strain**, Advanced Crane Technologies, LLC  
**J. Sturm**, Sturm Corp.  
**P. D. Sweeney**, Riverside Engineering, LLC  
**S. R. Fletcher**, *Alternate*, Cowles, Murphy, Glover & Associates  
**E. P. Vliet**, Turner Industries Group, LLC  
**J. D. Wiethorn**, Haag Engineering Co.  
**M. Gardiner**, *Alternate*, Haag Engineering Co.  
**R. C. Wild**, CJ Drilling, Inc.  
**J. Dudley**, *Alternate*, Archer Western Contractors  
**D. N. Wolff**, National Crane/Manitowoc Crane Group  
**J. A. Pilgrim**, *Alternate*, Manitowoc Cranes  
**S. D. Wood**, Terex Corp.  
**J. Lindsay**, *Alternate*, Link-Belt Construction Equipment

## HONORARY MEMBERS

**J. W. Downs, Jr.**, Downs Crane and Hoist Co.  
**J. L. Franks**, Consultant  
**C. W. Ireland**, National Oilwell Varco  
**J. M. Klibert**, Lift-All Co., Inc.  
**R. W. Parry**, Consultant

## B30.13 SUBCOMMITTEE PERSONNEL

**J. E. Richardson**, *Chair*, Navy Crane Center  
**J. Bresnahan**, Swisslog Logistics, Inc.  
**M. Felbinger**, Swisslog Logistics, Inc.  
**P. K. Gines**, Dematic North America

**G. G. Harris**, Westfalia Technologies, Inc.  
**G. B. Hetherston**, Consultant  
**D. P. Modzeleski**, Dematic Corp.  
**E. Nafziger**, Westfalia Technologies, Inc.

## B30 INTEREST REVIEW GROUP

**O. Akinboboye**, Ropetech Engineering Services  
**J. D. Cannon**, Consultant  
**B. Dobbs**, LEEA  
**M. J. Eggenberger**, Berry Contracting, Inc.  
**H. A. Hashem**, Saudi Aramco  
**J. Hui**, Southeast University, Nanjing  
**C. Lan**, U.S. Department of the Interior — Bureau of Safety and Environmental Enforcement

**A. C. Mattoli**, Prowinch, LLC  
**J. P. Mihlbauer**, All Ship and Cargo Surveys, Ltd.  
**G. L. Owens**, Consultant  
**D. R. Remus**, Reed Manufacturing  
**A. G. Rocha**, Belgo Bekaert Arames  
**C.-C. Tsauro**, Institute of Occupational Safety and Health

## B30 REGULATORY AUTHORITY COUNCIL

**C. Shelhamer**, *Chair*, New York City Department of Buildings  
**A. O. Omran**, *Alternate*, New York City Department of Buildings  
**K. M. Hyam**, *Secretary*, The American Society of Mechanical Engineers  
**M. J. Nelmida**, State of California — OSH Standards Board

**G. E. Pushies**, Michigan Occupational Safety and Health Administration  
**C. N. Stribling, Jr.**, Kentucky Labor Cabinet  
**T. Taylor**, State of Minnesota — Department of Labor and Industry



# SAFETY STANDARD FOR CABLEWAYS, CRANES, DERRICKS, HOISTS, HOOKS, JACKS, AND SLINGS

## B30 STANDARD INTRODUCTION

### (17) SECTION I: SCOPE

The ASME B30 Standard contains provisions that apply to the construction, installation, operation, inspection, testing, maintenance, and use of cranes and other lifting and material-movement related equipment. For the convenience of the reader, the Standard has been divided into separate volumes. Each volume has been written under the direction of the ASME B30 Standard Committee and has successfully completed a consensus approval process under the general auspices of the American National Standards Institute (ANSI).

As of the date of issuance of this Volume, the B30 Standard comprises the following volumes:

- B30.1 Jacks, Industrial Rollers, Air Casters, and Hydraulic Gantries
- B30.2 Overhead and Gantry Cranes (Top Running Bridge, Single or Multiple Girder, Top Running Trolley Hoist)
- B30.3 Tower Cranes
- B30.4 Portal and Pedestal Cranes
- B30.5 Mobile and Locomotive Cranes
- B30.6 Derricks
- B30.7 Winches
- B30.8 Floating Cranes and Floating Derricks
- B30.9 Slings
- B30.10 Hooks
- B30.11 Monorails and Underhung Cranes
- B30.12 Handling Loads Suspended From Rotorcraft
- B30.13 Storage/Retrieval (S/R) Machines and Associated Equipment
- B30.14 Side Boom Tractors
- B30.15 Mobile Hydraulic Cranes (withdrawn 1982 — requirements found in latest revision of B30.5)
- B30.16 Overhead Hoists (Underhung)
- B30.17 Cranes and Monorails (With Underhung Trolley or Bridge)
- B30.18 Stacker Cranes (Top or Under Running Bridge, Multiple Girder With Top or Under Running Trolley Hoist)
- B30.19 Cableways
- B30.20 Below-the-Hook Lifting Devices
- B30.21 Lever Hoists
- B30.22 Articulating Boom Cranes
- B30.23 Personnel Lifting Systems
- B30.24 Container Cranes
- B30.25 Scrap and Material Handlers
- B30.26 Rigging Hardware
- B30.27 Material Placement Systems
- B30.28 Balance Lifting Units
- B30.29 Self-Erecting Tower Cranes
- B30.30 Ropes
- B30.31 Self-Propelled, Towed, or Remote Controlled Hydraulic Platform Transporters<sup>1</sup>

### SECTION II: SCOPE EXCLUSIONS

Any exclusion of, or limitations applicable to the equipment, requirements, recommendations or operations contained in this Standard are established in the affected volume's scope.

### SECTION III: PURPOSE

The B30 Standard is intended to

- (a) prevent or minimize injury to workers, and otherwise provide for the protection of life, limb, and property by prescribing safety requirements
- (b) provide direction to manufacturers, owners, employers, users, and others concerned with, or responsible for, its application
- (c) guide governments and other regulatory bodies in the development, promulgation, and enforcement of appropriate safety directives

### SECTION IV: USE BY REGULATORY AGENCIES

These volumes may be adopted in whole or in part for governmental or regulatory use. If adopted for governmental use, the references to other national codes and standards in the specific volumes may be changed to refer to the corresponding regulations of the governmental authorities.

### SECTION V: EFFECTIVE DATE

(a) *Effective Date.* The effective date of this Volume of the B30 Standard shall be 1 yr after its date of issuance.

<sup>1</sup> This Volume is currently in the development process.

Construction, installation, inspection, testing, maintenance, and operation of equipment manufactured and facilities constructed after the effective date of this Volume shall conform to the mandatory requirements of this Volume.

(b) *Existing Installations.* Equipment manufactured and facilities constructed prior to the effective date of this Volume of the B30 Standard shall be subject to the inspection, testing, maintenance, and operation requirements of this Standard after the effective date.

It is not the intent of this Volume of the B30 Standard to require retrofitting of existing equipment. However, when an item is being modified, its performance requirements shall be reviewed relative to the requirements within the current volume. The need to meet the current requirements shall be evaluated by a qualified person selected by the owner (user). Recommended changes shall be made by the owner (user) within 1 yr.

## **SECTION VI: REQUIREMENTS AND RECOMMENDATIONS**

Requirements of this Standard are characterized by use of the word *shall*. Recommendations of this Standard are characterized by the word *should*.

## **SECTION VII: USE OF MEASUREMENT UNITS**

This Standard contains SI (metric) units as well as U.S. Customary units. The values stated in U.S. Customary units are to be regarded as the standard. The SI units are a direct (soft) conversion from the U.S. Customary units.

## **SECTION VIII: REQUESTS FOR REVISION**

The B30 Standard Committee will consider requests for revision of any of the volumes within the B30 Standard. Such requests should be directed to

Secretary, B30 Standard Committee  
ASME Codes and Standards  
Two Park Avenue  
New York, NY 10016-5990

Requests should be in the following format:

- Volume: Cite the designation and title of the volume.  
Edition: Cite the applicable edition of the volume.  
Subject: Cite the applicable paragraph number(s) and the relevant heading(s).  
Request: Indicate the suggested revision.  
Rationale: State the rationale for the suggested revision.

Upon receipt by the Secretary, the request will be forwarded to the relevant B30 Subcommittee for consideration and action. Correspondence will be provided to

the requester defining the actions undertaken by the B30 Standard Committee.

## **SECTION IX: REQUESTS FOR INTERPRETATION**

(17)

The B30 Standard Committee will render an interpretation of the provisions of the B30 Standard. An Interpretation Submittal Form is available on ASME's website at <http://cstools.asme.org/Interpretation/InterpretationForm.cfm>.

Phrase the question as a request for an interpretation of a specific provision suitable for general understanding and use, not as a request for approval of a proprietary design or situation. Plans or drawings that explain the question may be submitted to clarify the question. However, they should not contain any proprietary names or information. Read carefully the note addressing the types of requests that the B30 Standard Committee can and cannot consider.

Upon submittal, the request will be forwarded to the relevant B30 Subcommittee for a draft response, which will then be subject to approval by the B30 Standard Committee prior to its formal issuance. The B30 Standard Committee may rewrite the question for the sake of clarity.

Interpretations to the B30 Standard will be available online at <https://cstools.asme.org/Interpretation/SearchInterpretation.cfm>.

## **SECTION X: ADDITIONAL GUIDANCE**

The equipment covered by the B30 Standard is subject to hazards that cannot be abated by mechanical means, but only by the exercise of intelligence, care, and common sense. It is therefore essential to have personnel involved in the use and operation of equipment who are competent, careful, physically and mentally qualified, and trained in the proper operation of the equipment and the handling of loads. Serious hazards include, but are not limited to, improper or inadequate maintenance, overloading, dropping or slipping of the load, obstructing the free passage of the load, and using equipment for a purpose for which it was not intended or designed.

The B30 Standard Committee fully realizes the importance of proper design factors, minimum or maximum dimensions, and other limiting criteria of wire rope or chain and their fastenings, sheaves, sprockets, drums, and similar equipment covered by the standard, all of which are closely connected with safety. Sizes, strengths, and similar criteria are dependent on many different factors, often varying with the installation and uses. These factors depend on

- (a) the condition of the equipment or material
- (b) the loads
- (c) the acceleration or speed of the ropes, chains, sheaves, sprockets, or drums

(d) the type of attachments

(e) the number, size, and arrangement of sheaves or other parts

(f) environmental conditions causing corrosion or wear

(g) many variables that must be considered in each individual case

The requirements and recommendations provided in the volumes must be interpreted accordingly, and judgment used in determining their application.

# ASME B30.13-2017 SUMMARY OF CHANGES

Following approval by the ASME B30 Standard Committee and ASME, and after public review, ASME B30.13-2017 was approved by the American National Standards Institute on March 20, 2017.

ASME B30.13-2017 includes the following changes identified by a margin note, (17).

<i>Page</i>	<i>Location</i>	<i>Change</i>
viii–x	B30 Standard Introduction	Updated
1–4	Chapter 13-0	Title revised
	13-0.2.2	(1) Definitions of <i>administrative or regulatory authority; aisle pedestrian; ampacity; appointed; authorized; designated person; overspeed device; and switch, main</i> deleted
		(2) Definitions of <i>aisle, machine; brake; cab, carriage mounted; collectors, current; conductors, aisle(s); control braking means; drift point; fault conditions; load, design; load, rated; operational aid; pickup and deposit (P and D) station; rated load (capacity); runway; service platform; shall; should; storage/retrieval machine service, heavy; storage/retrieval machine service, normal; switch, emergency stop; switch, limit (sensor); and switch, master</i> revised
		(3) Definitions of <i>original language</i> added
	Section 13-0.3	References added
	Section 13-0.4	Added
5	13-1.1	Revised in its entirety
7	13-1.6.5	Revised
12, 13	13-1.11	Revised in its entirety
14	13-2.1	Revised
	13-2.1.1	(1) Subparagraph (b) revised (2) Subparagraphs (b)(1)(-c) and (b)(2)(-c) deleted
15	13-2.1.4	Revised
	13-2.1.5	Revised
	13-2.2.2	Revised
	13-2.3.1	Subparagraph (a) revised
16	13-2.4.1	(1) Paragraph added below title (2) Subparagraphs (a)(1) and (b)(2) revised

<i>Page</i>	<i>Location</i>	<i>Change</i>
17	13-2.5.1	Revised
	13-2.5.2	Subparagraph (a) revised
18	13-2.6.1	Paragraph added below title
	13-2.6.2	Subparagraph (b) revised
	13-2.7.1	(1) Paragraph added below title (2) Subparagraph (a)(1) revised
20	13-3.1.1	Subparagraphs (a)(2) and (b) revised
	13-3.1.4	Subparagraph (e) revised

# STORAGE/RETRIEVAL (S/R) MACHINES AND ASSOCIATED EQUIPMENT

## Chapter 13-0

(17)

### Scope, Definitions, References, and Personnel Competence

#### SECTION 13-0.1: SCOPE OF B30.13

Within the general scope defined in Section I, ASME B30.13 applies to storage/retrieval (S/R) machines and associated equipment, such as aisle transfer cars and aisle equipment (as defined in para. 13-0.2.1), and interfaces with other material handling equipment covered under other standards. The provisions of this Volume applying to S/R machines shall apply equally to the construction, installation, inspection, testing, maintenance, and operation of aisle transfer cars and any load handling equipment that is part of or attached to S/R machines or aisle transfer cars.

#### SECTION 13-0.2: DEFINITIONS

##### 13-0.2.1 Types of Equipment

*storage/retrieval (S/R) machine*: a machine operating on floor or other mounted rail(s) used for transferring a load from a storage compartment to a pickup and deposit (P and D) station and from a P and D station to a storage compartment. The movement of the storage/retrieval machine may be both vertical and parallel in the aisle. A storage/retrieval machine is sometimes called a storage crane or S/R machine, but it is different from a stacker crane. A typical unit load storage/retrieval machine is shown in Fig. 13-0.2.1-1.

*aisle transfer car*: a machine or vehicle for transferring an S/R machine from aisle to aisle and that normally runs on a rail or rails (see Fig. 13-0.2.1-2).

*automatic (S/R) machine*: an S/R machine that, when activated, operates through a preset program cycle or cycles.

*operator ridden (S/R) machine*: an S/R machine, with a cab attached to the machine and with an operator in the cab, whose movements can be controlled either manually or automatically (see Fig. 13-0.2.1-3).

*automatic or automatically*: pertains to equipment functions that do not require the attention of the operator during their functional operation.

*brake*: a device, other than a motor, used for retarding or stopping motion by means of friction or power.

*bumper*: an energy absorbing device for reducing impact when a moving S/R machine reaches the end of its permitted travel, or when two moving S/R machines come into contact.

*cab*: the operator's compartment on the equipment.

*carriage*: that part of an S/R machine by which a load is moved in the vertical direction.

*carriage free-fall stop*: a mechanism used to prevent or stop uncontrolled descent of the carriage in event of loss of support.

*carriage-mounted cab*: an operator's cab that is attached to the carriage of an S/R machine and moves vertically with the carriage.

*clearance*: the distance between loads, structure, and equipment calculated to allow for operating and installation tolerances, deflections, load displacement, and load integrity.

*collectors*: contacting devices for collecting current from aisle conductors.

*control braking*: a method of controlling speed by removing energy from the moving body or by imparting energy in the opposite direction.

*control voltage*: electrical voltage used in the control components and circuits.

*design load*: the maximum length, width, height, and weight of a load handled, including any pallet, container, slave pallet, or stacking tolerances.

*drift point*: a point on a travel motion master switch or on a manual controller that maintains the brake released while the motor is not energized. This allows for coasting.

##### (17) 13-0.2.2 General

*aisle conductors*: electrical feeders along the runway that provide power to the equipment.

Fig. 13-0.2.1-1 Typical Unit Load S/R Machine

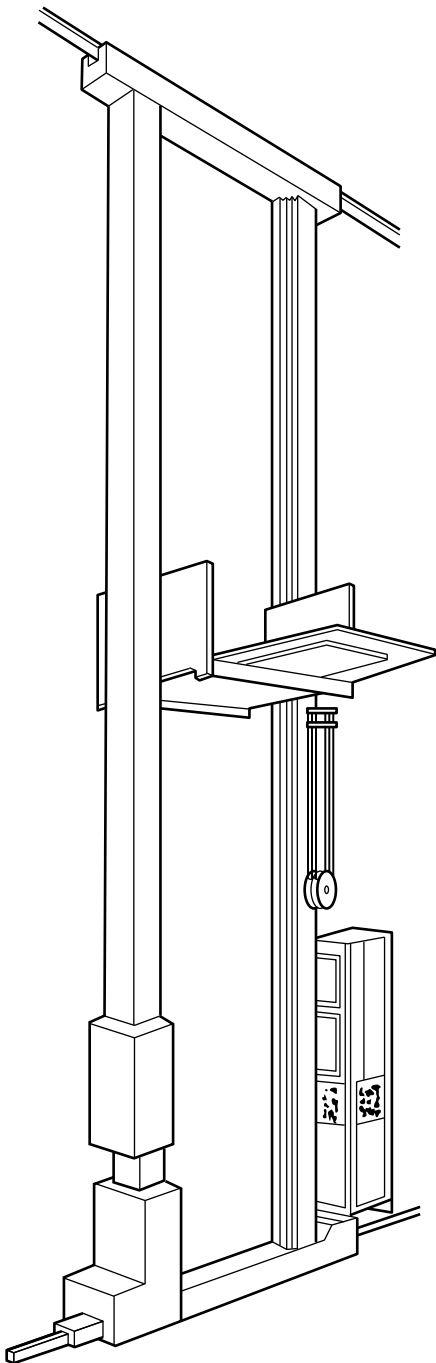
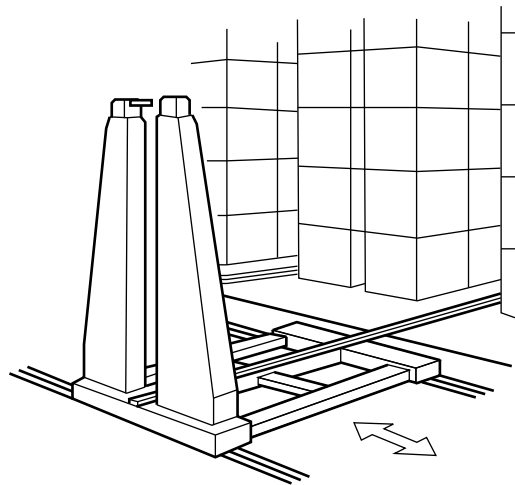

Fig. 13-0.2.1-2 Typical Aisle Transfer Car



*emergency stop switch:* a manually or automatically operated switch to cut off power independently of the regular operating controls.

*fault condition:* a malfunction caused by overload, travel beyond set limits, emergency stop, or failure of components essential to safe operation of the equipment.

*heavy service:* service that involves operating at 85% to 100% of the rated load, or in excess of 10 lift cycles/hr, as a regular specified procedure.

*hoist:* a machinery unit that is used for lifting and lowering.

*hoist chain:* a roller or calibrated link chain in a hoist that supports the carriage.

*hoist motion:* the motion of a storage crane that lifts and lowers the carriage.

*limit sensor:* a device that is operated by some part or motion of a power-driven machine or equipment to alter the circuit associated with the machine or equipment.

*load sizing:* a process to determine that the loads are dimensionally acceptable for storage.

*machine aisle:* space between storage compartment rows in which the S/R machine operates.

*manual operation:* pertains to equipment functions that require action by the operator.

*master switch:* a switch that dominates the operation of contactors, relays, or other remotely operated devices.

*minimum breaking force:* the minimum load at which a new and unused wire rope will break when loaded to destruction in direct tension.

*normal service:* service that involves operating at less than 85% of the rated load and not more than 10 lift cycles/hr, except for isolated instances.

**Fig. 13-0.2.1-3 Typical Operator Ridden S/R Machine**

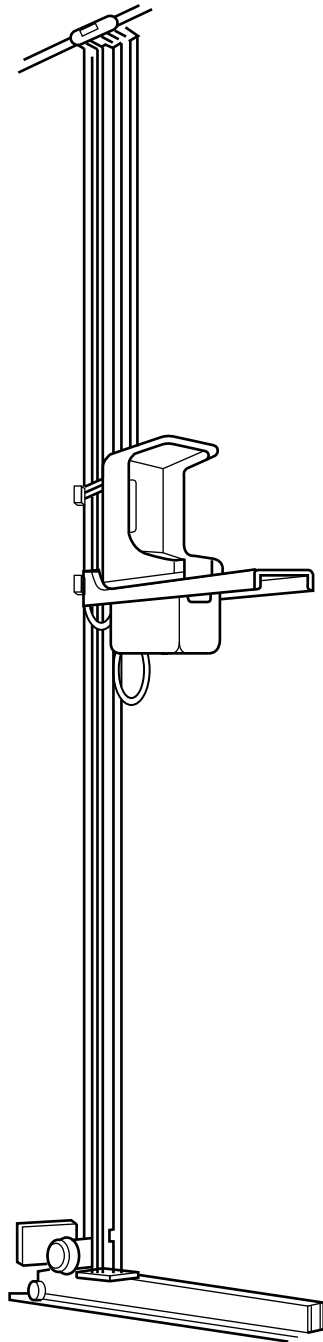

*operational aid*: an accessory that provides information to facilitate operation of the equipment or that takes control of particular functions without action by the operator when a limiting condition is sensed.

*original language(s)*: language(s) used by the manufacturer to develop product instructions and manual(s).

*pickup and deposit (P and D) station*: a location at which a load entering or leaving storage is supported in a manner suitable for handling by the S/R machine. Prior usage has also called this the transfer station, I/O, pickup and delivery station, or feed/discharge station.

*qualified person*: a person who, by possession of a recognized degree in an applicable field, or certificate of professional standing, or by extensive knowledge, training, and experience, has successfully demonstrated the ability to solve or resolve problems relating to the subject matter and work.

*rated load (capacity)*: the maximum load designated by the manufacturer for which the equipment is designed and built.

*rated load speed*: the maximum speed at which the S/R machine or aisle transfer car motions are designed to operate under rated load.

*remote operation*: an S/R machine or aisle transfer car operation in which the motions are controlled or directed from a location other than the machine.

*retrieve*: to move a desired load from a predetermined, occupied compartment to a P and D station.

*rope*: refers to wire rope unless otherwise specified.

*running sheave*: a sheave that rotates as a load carriage is lifted or lowered.

*runway*: an assembly of rails, beams, girders, brackets, or framework on which the equipment travels.

*sensor*: a device that responds to a physical stimulus and transmits the resulting signal.

*service platform*: a means provided for workers to perform maintenance, inspection, adjustment, or repair of equipment.

*shall*: a word indicating a requirement.

*should*: a word indicating a recommendation.

*shuttle*: the load supporting mechanism on the carriage that provides for movement of loads into or out of storage compartments or transfer stations.

*slave pallet or slave container*: a handling base or container that is normally captive to a system on which a unit load is supported.

*stop*: a device to limit travel. This device normally is attached to a fixed structure and normally does not have energy absorbing ability.

*storage location or compartment*: the space into which a given unit load is stored. It is dimensioned by the unit



load sizes plus all working clearances and tolerances required, including any pallet if part of a system.

*store*: to move a load from a pickup and deposit (P and D) station into a predetermined, unoccupied compartment.

*switch*: a device for making, breaking, or for changing the connections in an electric circuit.

*tolerance*: the allowance made for manufacturing and installation variances from nominal dimensions.

*travel*: movement in a direction parallel to the runway.

### (17) SECTION 13-0.3: REFERENCES TO OTHER CODES AND STANDARDS

Within the text, reference is made to the following publications, copies of which may be obtained from the publishers as indicated.

ANSI/AWS D1.1-2010, Structural Welding Code — Steel<sup>1</sup>

ANSI/AWS D14.1-2005, Specification for Welding of Industrial and Mill Cranes and Other Material Handling Equipment<sup>1</sup>

Publisher: American Welding Society (AWS), 8669 NW 36 Street, No. 130, Miami, FL 33166 (<http://www.aws.org>)

ANSI/NFPA 70-2011, National Electrical Code<sup>1</sup>

Publisher: National Fire Protection Association (NFPA), 1 Batterymarch Park, Quincy, MA 02169-7471 (<http://www.nfpa.org>)

<sup>1</sup> May also be obtained from American National Standards Institute (ANSI), 25 West 43rd Street, New York, NY 10036.

ANSI/SAE Z26.1-1983, Safety Glazing Materials for Glazing Motor Vehicles and Motor Vehicle Equipment Operating on Land Highways — Safety Standard  
Publisher: SAE International, 400 Commonwealth Drive, Warrendale, PA 15096 (<http://www.sae.org>)

ANSI Z535.4-2011, Product Safety Signs and Labels  
Publisher: National Electrical Manufacturers Association (NEMA), 1300 North 17th Street, Suite 900, Arlington, VA 22209 (<http://www.nema.org>)

ASSE Z359.1-2007, Safety Requirements for Personal Fall Arrest Systems, Subsystems and Components  
Publisher: The American Society of Safety Engineers (ASSE), 520 N. Northwest Hwy, Park Ridge, IL 60068 (<http://www.asse.org>)

ISO 7000:2014, Graphical symbols for use on equipment — Registered symbols

ISO 7296-1/AMD1:1996, Cranes — Graphical symbols — Part 1: General

Publisher: International Organization for Standardization (ISO), Central Secretariat, Chemin de Blandonnet 8, Case Postale 401, 1214 Vernier, Geneva, Switzerland (<http://www.iso.org>)

### SECTION 13-0.4: PERSONNEL COMPETENCE (17)

Persons performing the functions identified in this Volume shall, through education, training, experience, skill, and physical fitness, as necessary, be competent and capable to perform the functions as determined by the employer or employer's representative.

# Chapter 13-1

## Construction and Installation

### (17) SECTION 13-1.1: SIGNS AND LABELS

#### 13-1.1.1 S/R Machine Load Signs and Labels

Signs or labels shall be visible to the operator(s).

- (a) The rated load of the S/R machine shall be shown.
- (b) If the S/R machine stores more than one design load, each design load size shall be shown.

#### 13-1.1.2 Safety Signs and Labels (Operator Ridden S/R Machines)

Operator ridden S/R machines shall have affixed to them and to the S/R machine aisle entrance points or access positions, in a readable position, a sign(s) or labels displaying the following information concerning operating procedures. Signs or labels shall be in compliance with ANSI Z535.4:

- (a) the appropriate signal word for the hazard
- (b) cautionary language against
  - (1) unauthorized personnel entering the machine aisle
  - (2) designated personnel entering the machine aisle while the S/R machine is in normal operation
  - (3) operating S/R machines other than by designated personnel
  - (4) clearing any malfunctions other than by designated personnel
  - (5) removing or obscuring safety signs or label(s)

#### 13-1.1.3 Safety Signs and Labels (Automatic S/R Machines)

Each aisle entrance point to automatic S/R machines shall have affixed to it, in a readable position, a sign(s) or label(s) displaying the following information. Signs or labels shall be in compliance with ANSI Z535.4:

- (a) the appropriate signal word for the hazard
- (b) cautionary language against
  - (1) personnel entering the machine aisle, unless the system is designed and interlocked to prevent personnel from entering the machine aisle while the machine is in operation and to prevent operation of the machine while personnel are in the aisle
  - (2) removing or obscuring safety signs or label(s)

### SECTION 13-1.2: CLEARANCES

#### 13-1.2.1 Clearances Within System

The clearances and tolerances within the system are based on the design for proper operation and are determined by the manufacturer and the user or his representative with consideration given to factors such as

- (a) load configuration
- (b) storage structure and equipment configuration
- (c) degree of interaction with operating, inspection, and maintenance personnel
- (d) allowance for building variations

### SECTION 13-1.3: GENERAL CONSTRUCTION

#### 13-1.3.1 Foundations and Anchorage

The foundations and anchorage shall be constructed to accommodate the equipment loadings specified by the manufacturer.

#### 13-1.3.2 S/R Machine Runways

The runways for S/R machines shall be constructed to accommodate the wheel loadings specified by the manufacturer.

##### 13-1.3.2.1 Floor-Mounted or Rack-Mounted Runways

- (a) *Construction of Runways*
  - (1) The S/R machine runways and supporting structures shall be designed to withstand the loads and forces imposed by the S/R machine under normal operating conditions.
  - (2) The structure shall be free from detrimental vibration under normal operating conditions.
  - (3) Rails shall be level, straight, and joined to be compatible with the design of the S/R machine.
- (b) *Runway Stops*
  - (1) Stops shall be provided at the limits of travel of the S/R machine and aisle transfer car.
  - (2) Stops shall be designed to withstand the forces applied to the stops as specified in para. 13-1.7.1.

#### 13-1.3.3 Welded Construction

All welding procedures and welding operator qualifications to be used on load sustaining members shall be in accordance with ANSI/AWS D1.1 except as modified by ANSI/AWS D14.1. Where special steels or other materials are used, the manufacturer of the S/R machine shall provide welding procedures.

#### 13-1.3.4 Modifications

S/R machines may be modified or rerated, provided such modifications and the supporting structure are analyzed by a qualified person or the manufacturer. A rerated machine or one whose load-supporting components have been modified shall be tested in accordance with para. 13-2.2.2. New rated load or design load shall be displayed in accordance with para. 13-1.1.1.

### SECTION 13-1.4: CABS

#### 13-1.4.1 Cab Location on an Operator Ridden S/R Machine

(a) The general arrangement of the cab and location of the control equipment shall be such that all devices necessary to select, initiate, or terminate an automatic cycle or to start or stop each manually controlled operation are within convenient reach of the operator.

(b) The cab shall be clear of all fixed structures within its area of possible movement.

#### 13-1.4.2 Cab Construction

(a) The cab interior construction should protect the operator from knobs, edges, or corners in the event of sudden crane accelerations or decelerations.

(b) The cab should be constructed and installed to minimize swaying or vibration.

(c) In the absence of an outside platform, the door, if provided, shall open inward or slide and be self-closing. It shall be equipped with positive latching devices to prevent inadvertent opening.

(d) Emergency exit means to the floor shall be provided for all positions of a carriage-mounted cab.

(e) While the machine is in motion, all parts of the operator's body shall be kept within the design clearances by the construction of the cab, by hands-on, feet-in-place operating type controls, or by mechanical restraints interlocked with motion controls.

(f) All cab glazing shall be safety glazing material as defined in ANSI Z26.1.

(g) The crane operator shall be protected from falling objects at the normal work station. The protection required shall be based upon the materials being stored and their height. Protection such as an overhead guard or cab location is acceptable. The operator protection shall be designed by a qualified person.

(h) Means shall be provided to limit horizontal displacement of a pallet or container on a carriage toward the operator.

(i) Materials that will propagate combustion or rekindle shall not be used in the construction of the cab.

#### 13-1.4.3 Fire Extinguisher

A portable fire extinguisher, with a basic minimum extinguisher rating of 10 BC, shall be installed in the cab.

#### 13-1.4.4 Lighting

Cab lighting, either natural or artificial, shall provide a level of illumination that enables the operator to observe the operating controls.

### SECTION 13-1.5: LUBRICATION

Lubricating points should be accessible from walkways, floor(s), or platforms without the necessity of removing guards or other parts.

### SECTION 13-1.6: PLATFORMS, LADDERS, AND PERSONNEL ACCESS TO AISLES AND RUNWAYS

#### 13-1.6.1 Location of Platforms

Service platforms, fixed or removable, should be provided as required for access to controls and other maintenance items.

#### 13-1.6.2 Construction of Platforms

(a) Platforms shall be designed to sustain a distributed load of at least 50 lb/ft<sup>2</sup> (2.4 kPa).

(b) Platforms shall have a slip-resistant walking surface.

(c) Handrails for platforms shall be 36 in. (915 mm) to 42 in. (1 067 mm) high with an intermediate rail and a 4 in. (102 mm) to 6 in. (152 mm) toeboard.

(d) Ladder access openings in the platform floor should be approximately 24 in. (610 mm) × 27 in. (685 mm) protected with a hinged hatch cover.

(e) When platforms are provided for personnel who ride on the carriage outside the cab, they shall be equipped with the following:

(1) a flat slip-resistant surface upon which to stand, either on the carriage or on a portable platform/surface attached to the carriage

(2) a fall arrest anchorage at shoulder height or higher, meeting the requirements of ASSE Z359.1

(3) a means of communication between the operator and the person on the carriage

(4) a means of "emergency stop" that is available to the person on the carriage

(5) a handhold for each person on the carriage

#### 13-1.6.3 Fixed Ladders

Fixed ladders, if provided, shall meet the following requirements:

(a) the minimum design live load shall be a single concentrated load of 250 lb (113 kg), concentrated at such a point that will cause maximum stress in the structural member being considered.

(b) rungs shall have a minimum diameter of  $\frac{3}{4}$  in. (19 mm), a maximum distance between rungs of 12 in. (305 mm), and a minimum clear width of 16 in. (406 mm).

(c) a minimum climbing space of 15 in. (381 mm) each way from the centerline of the ladder and 30 in. (762 mm) on the climbing side of the ladder shall be provided except when inside cages or hatchways are used.

(d) the distance from the centerline of the rungs to the nearest permanent object in back of the ladder shall be not less than 7 in. (178 mm).

(e) on ladders over 20 ft (6 m) in height, cages shall be provided from a point not more than 8 ft (2.4 m) above the floor, to a point not less than 3 ft 6 in. (1.1 m) above the landing platform unless safety devices as per (f) are provided. Such cages shall be at least 27 in. (685 mm) clear inside diameter.

(f) ladder safety devices may be used on ladders over 20 ft (6 m) in unbroken height in lieu of cage protection. All ladder safety devices such as those that incorporate life belts, friction brakes, and sliding attachments shall meet the design requirements of the ladders that they serve.

(g) when exiting at the top of the ladder, handrails of at least 3 ft 6 in. (1.1 m) shall extend vertically from the top level of the ladder; otherwise, the ladder will extend an additional similar distance above the point of exit.

#### 13-1.6.4 Access to Cab or Service Platform

Access to the cab or service platform shall be by means requiring no step over any gap exceeding 12 in. (305 mm).

#### (17) 13-1.6.5 Personnel Access to Machine Aisles and Runways

Machine aisles and runways shall be clearly identified by signage to indicate they are for use only by designated personnel.

### SECTION 13-1.7: STOPS, BUMPERS, INTERLOCKS, SWEEPS, AND GUARDS

#### 13-1.7.1 Stops

Mechanical means shall be provided for preventing the shuttle from becoming disengaged from its support(s).

#### 13-1.7.2 Bumpers for S/R Machines and Aisle Transfer Cars

(a) S/R machines or aisle transfer cars shall be provided with bumpers or other means capable of stopping the equipment including the rated load when traveling in either direction at 100% of the rated load speed without structural damage to the equipment. When devices other than bumpers are provided for this purpose, they shall operate independently from all other power, drive, and electrical systems on the S/R machine or aisle transfer car.

(b) The application of the stopping force shall not cause the S/R machine or the aisle transfer car to overturn.

(c) When more than one S/R machine or aisle transfer car is located and operated on the same runway, bumpers or other means shall be provided on their adjacent ends to meet the stopping requirements specified in (a) and (b). When devices other than bumpers are used, the application of such devices shall be based on sensing the physical position of other S/R machines or aisle transfer cars at a safe enough distance to ensure sufficient braking application to prevent collision.

(d) As an additional requirement for operator ridden S/R machines and for machines that may be ridden by other personnel, bumpers or other means shall be provided that are capable of stopping the S/R machine (including the rated load) at a deceleration that shall not exceed 16 ft/sec<sup>2</sup> (4.9 m/s<sup>2</sup>) when travelling in either direction at 50% of the rated load speed.

#### 13-1.7.3 Runway Interlocks

(a) Interlocks shall prevent S/R machine travel between the aisle and aisle transfer car unless the tracks in the aisle and on the transfer car are aligned. Also, travel of the transfer car shall be prevented unless the S/R machine is completely on or off the transfer car.

(b) Means should be provided to limit the drop of the S/R machine frame to 1/2 in. (13 mm) in case of wheel or axle breakage. Also, a means should be provided to limit the lateral movement in the event of wheel or axle breakage.

#### 13-1.7.4 Runway Sweeps

Runway sweeps shall be provided in front of the runway wheels to provide clear passage for the wheels.

#### 13-1.7.5 Guards for Hoisting Ropes, Chains, or Belts

If it is possible for hoisting ropes, chains, or belts to foul or chafe on adjacent parts of the S/R machine under normal operating conditions, guards shall be installed to minimize damage.

#### 13-1.7.6 Guards for Moving Parts

(a) Exposed moving parts such as gears, set screws, projecting keys, ropes, chains, chain sprockets, belts, and reciprocating components that might constitute a hazard under normal operating conditions shall be guarded.

(b) Each guard shall be capable of supporting without permanent deformation the weight of a 200 lb (90 kg) person unless the guard is located where it is not reasonable to expect a person to step during operation or maintenance.

### SECTION 13-1.8: BRAKES

#### 13-1.8.1 Brakes for Electric Hoists

(a) Each independent hoisting unit of an S/R machine shall be equipped with at least one holding brake,

applied directly to the motor shaft or some part of the gear train.

(b) Each independent hoisting unit of an S/R machine, except worm-gear hoists, the angle of whose worm is such as to prevent the load from accelerating in the lowering direction, shall, in addition to a holding brake, be equipped with control braking means to control lowering speeds.

### 13-1.8.2 Holding Brakes

(a) Holding brakes for hoist motors shall have a rating not less than the following percentage of the full load hoisting torque at the point where the brake is applied:

(1) 125% when used with a control braking means other than mechanical

(2) 100% when used with a mechanical control braking means

(3) 100% each if two holding brakes are provided

(b) Holding brakes on hoists shall have thermal capacity for the frequency of operation required by the service.

(c) Holding brakes shall be applied automatically when power to the brake is removed.

(d) Holding brakes shall be provided with means to compensate for lining wear.

(e) The wearing surface of all brake wheels, drums, or disks shall be free of defects that interfere with the operation.

### 13-1.8.3 Control Braking Means

(a) An electrical control braking means (such as regenerative, dynamic, counter-torque, or eddy current braking), a mechanical, or a hydraulic control braking means shall be capable of maintaining controlled travel or lowering speeds.

(b) The control braking means shall have thermal capacity for the frequency of operation required by the service.

### 13-1.8.4 Horizontal Travel and Shuttle Brakes

(a) This paragraph does not apply to horizontal shuttle drives that do not require a brake to stop motion or hold position.

(b) Brakes shall be provided for horizontal travel and shall be applied automatically when power to the brake is removed, but shall not prohibit the use of a drift point in the control circuit.

(c) Brakes shall be provided with means to compensate for lining wear.

(d) The wearing surfaces of all brake wheels, drums, or disks shall be free of defects that interfere with the operation.

(e) Holding brake torque shall be sufficient to decelerate the S/R machine from rated speed by at least  $1 \text{ ft/sec}^2$  ( $0.3 \text{ m/s}^2$ ) and shall be capable of decelerating the S/R machine to a complete stop from rated speed.

(f) Brakes shall have thermal capacity for the frequency of operation required by the service.

## SECTION 13-1.9: ELECTRICAL EQUIPMENT

### 13-1.9.1 General

(a) The provisions of this Section shall only apply to S/R machines, aisle transfer cars, and any load handling equipment that is part of or attached to S/R machines or aisle transfer cars.

(b) If resistor enclosures are provided, they shall be installed to prevent the accumulation of combustible matter.

(c) *Wiring Outside of Control Enclosures on an S/R Machine or Aisle Transfer Car*

(1) Conductors external to control cabinets shall be enclosed in raceways or be protected cable, such as but not limited to types ALS, CS, or MI cable, subject to the exception that contact conductors, that are fully insulated except as necessary to provide access for collector shoes, may be used to service moving portions of such machines.

(2) Rubber, thermoplastic, or synthetic polymer insulation may be used in accordance with Table 310-2(a) of ANSI/NFPA 70.

(3) The allowable ampacities of conductors shall be as shown in ANSI/NFPA 70, Table 610-14(a). For the ampacities of conductors between controllers and resistors, see ANSI/NFPA 70, Section 430-23. The ampacities of conductors within flexible cords or cables shall be in accordance with ANSI/NFPA 70, Article 400.

(4) Individual conductors run in conduits and raceways or within jacketed multiple conductor wire shall not be smaller than No. 16.

(5) Flexible cords or cables that are part of special sensors or appliances and that conform to Articles 400 and 725 of ANSI/NFPA 70 may be used in short runs outside conduits or raceways.

(d) *Wiring Within Control Enclosures*

(1) When an S/R machine carriage is operator ridden, the wiring shall be flame-retardant and moisture-resistant, and panel wiring to the main circuit resistors shall be suitable for a temperature of not less than  $194^\circ\text{F}$  ( $90^\circ\text{C}$ ).

(2) The allowable ampacity of conductors shall be as shown in ANSI/NFPA 70, Table 610-14(a), except for low energy power, low voltage power, and signal circuits conforming with the definitions and classifications of Article 725 of ANSI/NFPA 70.

(3) *Minimum Conductor Size*

(-a) Wiring other than low energy power, low voltage power, and signal circuits conforming with the definitions and classifications of Article 725 of ANSI/NFPA 70 shall not be smaller than No. 16.

(-b) Low energy power, low voltage power, and signal circuits may use any size wire consistent with the

classification and limitations of Article 725 of ANSI/NFPA 70.

(e) Traveling cables used as flexible connections between the S/R machine carriage and the S/R machine main frame shall be of the types of cable listed for this service in ANSI/NFPA 70.

(1) Traveling cables shall be so suspended at the carriage and S/R machine frame end as to reduce the strain on the individual conductors. Cables with an unsupported length exceeding 100 ft (30 m) shall have supporting fillers and shall be suspended directly by the supporting fillers. Where nonmetallic fillers are used, the cables shall be suspended by looping the cables around the supports, or shall be suspended from the support by a means that automatically tightens around the cable when tension is increased.

(2) In hazardous locations, traveling cables shall be of a type designed for hazardous locations and shall be secured to explosion-proof cabinets as provided in Section 501-11 of ANSI/NFPA 70.

(3) Traveling cable supports shall be so located as to reduce the possibility of damage due to the cables coming in contact with fixed structures or loads within their area of possible movement. Where necessary, guards shall be provided to protect the cables against damage.

(f) *Contact Conductor Installation*

(1) The open access for collector shoes should be facing to the side or downward to minimize the chance either of contamination or of contact with metal objects.

(2) Collector shoes shall be either guarded or located in such a way that inadvertent contact with adjacent, exposed, and energized shoes is prevented, even when traversing a gap.

(3) Adjacent sections of conductor bar that are energized from separate power sources shall be separately protected and isolated.

(4) Collectors should be so constructed as to reduce to a minimum sparking between them and the contact conductors. When operated in rooms used for storage of combustible materials, the requirements of ANSI/NFPA 70, Section 503-13 shall apply.

(5) Conductors of the open type should not be used. However, if conductors of the open type are used, they shall be so located or so guarded that the operator in the cab and persons utilizing the means provided to enter or leave the cab, service platform, or aisle cannot come into contact with the conductors or energized portions of the associated collectors.

(g) *Grounding*

(1) All exposed metal parts of S/R machines or aisle transfer cars, including any pendant controls, shall be metallicity joined together into a continuous electrical conductor so that the entire machine will be grounded on installation. Parts having metal to metal bearing surfaces shall be considered to be electrically

connected to each other through the bearing surfaces for grounding purposes.

(2) A carriage grounding conductor shall be used. The carriages shall not be considered grounded by metal hoisting ropes or by metal chains, attached to or running over sheaves, drums, or sprockets.

(h) Insulated contact conductors may be used for signals, controls, or power to the S/R machine carriage. Associated collectors shall be so located and guarded as to be out of reach of an operator performing assigned work. All wiring on structure adjacent to the carriage shall be insulated for the maximum voltage to which the conductors are subjected.

(i) Where multiple conductor cable is used with a suspended pushbutton station, the station shall be supported so that the electrical conductors are relieved from strain. Pendant control stations shall be constructed to prevent electrical shock. The pushbutton enclosure shall be at ground potential, marked for identification of functions, and designed to minimize inadvertent operation.

(j) If the electrical system design permits conductors for operating control, power, signal, communication, and light circuits of 600 V or less to be run in the same traveling cable or raceway system, all conductors shall be insulated for the maximum voltage found in the cables or raceway system and all live parts of the equipment shall be insulated from the ground for this maximum voltage.

### 13-1.9.2 Equipment

(a) Electrical equipment shall be so located or enclosed that live parts will not be exposed to accidental contact under normal operating conditions.

(b) Live parts of electrical equipment shall be protected from direct exposure to grease, oil, and moisture, and should be protected from dirt.

(c) Guards for live parts, if provided, shall be constructed or located in such a way that they cannot be inadvertently deformed as to make contact with the live parts.

### 13-1.9.3 Power Disconnect

(a) An aisle disconnecting means shall be provided between the power supply and the aisle contact conductor or traveling cable. Such disconnecting means shall consist of a motor circuit switch or circuit breaker. This disconnecting means shall be accessible and operable, arranged to be locked in the open position, and open all ungrounded power supply circuits simultaneously.

(b) A disconnecting means for the power supply to an aisle transfer car shall be provided as described in (a).

(c) A disconnecting means for an S/R machine or an aisle transfer car shall be provided in the leads from contact collector shoes or any other feeder to the S/R machine or aisle transfer car. This disconnecting means shall be accessible, arranged to be locked in the

open position, and open all ungrounded power supply circuits simultaneously. On an operator ridden machine or aisle transfer car, a separate means to open the power supply to all the drive motors shall be provided at the operator's station, when the mainline disconnecting means cannot be placed within reach of the operator.

#### 13-1.9.4 Limit Sensors

(a) Limit sensors shall be provided, connected, and actuated to shut down any drive whose motion passes the extremity of designed travel.

(b) Limit sensors may be used on multispeed or adjustable speed drives to reduce speed before actuating the extreme travel sensor at the end of travel.

#### 13-1.9.5 Control Voltages

The voltage at pendant controls, manual operators, or pushbutton stations shall not exceed 150 V AC or 300 V DC.

#### 13-1.9.6 Controls for Operator Ridden Operation

Unless the operator's cab is constructed in a way that prevents the extension of arms and legs into a storage aisle while the machine is in motion, the operating switches shall be arranged so that both hands and both feet are required to be in specified positions in order to permit horizontal motion of the S/R machine as a whole, or vertical motion of the occupied operator ridden carriage. Where such motions are under automatic control, control sequences may proceed only when the switches are all activated by the operator. If, during an automatic sequence, any of the above switches becomes nonactivated, all S/R machine drives shall stop. The control sequence shall revert to a controlled start point status. Automatic operating sequences shall not be resumed until there has been a time delay after the reactivation of all switches so as to prevent a chattering type of motion that might cause structural damage or shift loads. Controls shall be labeled in words or symbols to indicate their function and, where appropriate, the direction of motion imparted.

#### 13-1.9.7 Warning Devices

(a) Visual or audible warning devices shall be located on any S/R machine or aisle transfer car within an automatic system and shall be activated whenever the S/R machine as a whole makes any horizontal movement. Such devices shall be located where they can be seen or heard by persons in a machine aisle or in work stations into which mobile machines may move.

(b) Personnel operating manned remote control S/R machines or aisle transfer cars performing any manned hoist operation shall have a means of alerting others to secure aid in case of emergency or malfunction.

#### 13-1.9.8 Fault Conditions

(a) The following conditions shall be classified as S/R machine faults:

- (1) travel beyond set limits in any axis of motion where such motion is possible
- (2) loss of support of an S/R machine carriage
- (3) activation of any emergency stop switch
- (4) sensing any electrical overload or power failure
- (5) malfunction of storage or retrieval of a load that results in the load or shuttle protruding into the design clearances

(b) The following conditions shall be classified as aisle transfer car faults:

- (1) travel beyond set limits
- (2) activation of any emergency stop switch
- (3) sensing any electrical overload or power failure
- (4) failure to satisfy runway interlock conditions as described in para. 13-1.7.3

(c) Fault conditions, however sensed, shall cause applicable drive motors to be disconnected from their power source by opening contactors.

(d) Fault sensors should be designed so that component failure or power loss results in a fault condition being sensed.

(e) If there is any reason for personnel to be in the machine aisle, emergency stop actuators shall be accessible to such personnel. Actuating emergency stop shall result in a fault condition.

(f) Correcting the fault shall not cause the automatic cycling to be reestablished without performing a specific starting procedure.

#### 13-1.9.9 Automatic and Remote Operations

(a) Automatic S/R machines and aisle transfer cars shall be designed so that the operation of all motions is discontinued if the automatic sequence control becomes ineffective. The completion of the last command is permissible if power is available.

(b) Remote operated S/R machines and aisle transfer cars that require continuity of the remote signal in order to operate shall function in such a way that if the control signal for any motion becomes ineffective, the motion shall stop.

(c) Means shall be provided to prevent the transmission of remote command signals to the S/R machine and aisle transfer car. Means shall also be provided on the S/R machine and aisle transfer car to prevent responding to the remote command signals.

(d) When controls are provided for the manual operation of automatic or remote S/R machines or aisle transfer cars, all sensors of fault conditions as defined in para. 13-1.9.8 shall remain operational during the manual mode of operation. Additional controls for the purpose of maintenance operations and/or clearing malfunctions may be provided to override the fault conditions.

### 13-1.9.10 Controls for Travel of Personnel on the Carriage Outside the Cab

Where personnel are required to be on the carriage outside the cab, travel shall be controlled by manually operated, return-to-off controllers.

## SECTION 13-1.10: HOISTING EQUIPMENT

### 13-1.10.1 Sheaves

(a) Sheave grooves shall be smooth and free from surface defects that could cause rope damage. The cross-sectional radius at the bottom of the groove should form a close-fitting saddle for the size of rope used and the sides of the groove should be tapered outwardly to facilitate entrance of the rope into the groove. Flange corners should be rounded and the rims should run true about the axis of rotation.

(b) Sheaves carrying ropes that can be momentarily unloaded shall be provided with close-fitting guards or other devices to guide the rope back into the groove when the load is reapplied.

(c) Means shall be provided to minimize chafing of the ropes during normal operation.

(d) All running sheaves shall be equipped with means for lubrication. Permanently lubricated, sealed, or shielded bearings shall be acceptable.

(e) The pitch diameter of running sheaves should not be less than 20 times the rope diameter.

(f) The pitch diameter of nonrunning sheaves should not be less than 18 times the rope diameter.

(g) Sheave pitch diameter, in relation to rope diameter, will have an effect on the wear of the rope. Therefore, rope inspection as given in para. 13-2.4.1 shall be followed.

### 13-1.10.2 Drums

Rope drums shall be grooved except when the S/R machine is provided by the manufacturer for a special application. The grooves shall be free from surface defects that could cause rope damage. The cross-sectional radius at the bottom of the groove should form a close-fitting saddle for the size of rope used.

### 13-1.10.3 Ropes

(a) The hoisting ropes shall be of a recommended construction for S/R machine service. The rated load plus the carriage weight divided by the number of parts of rope shall not exceed 20% of the minimum breaking force of the rope.

(b) Socketing shall be done in the manner specified by the manufacturer of the socket assembly or the rope manufacturer.

(c) Rope shall be secured to the drum as follows:

(1) no less than two wraps of rope shall remain on the drum when the carriage is in its extreme low position.

(2) the rope end shall be anchored by a clamp attached to the drum, or by a socket arrangement specified by the S/R machine or rope manufacturer. The rope clamps shall be tightened evenly to the manufacturer's recommended torque.

(d) Eye splices shall be made by a qualified person. Rope thimbles should be used in the eyes.

(e) Wire rope clips shall be drop-forged steel of the single saddle (U-bolt) or double saddle type clip. Malleable cast iron clips shall not be used. For spacing, number of clips, and torque values, refer to the clip manufacturer's recommendation. Wire rope clips attached with U-bolts shall have the U-bolt over the dead end of the rope and the live rope resting in the clip saddle. Clips shall be tightened evenly to the recommended torque. After the initial load is applied to the rope, the clip nuts shall be retightened to the recommended torque to compensate for any decrease in rope diameter caused by the load. Rope clip nuts should be retightened periodically to compensate for any further decrease in rope diameter during usage.

(f) Swaged or compressed fittings shall be applied as recommended by the fitting, the rope, or the S/R machine manufacturer.

(g) Wherever exposed to ambient temperatures above 180°F (82°C), rope having an independent wire-rope or wire-strand core, or other temperature-resistant core shall be used.

(h) Replacement rope shall be the same size, grade, and construction as the original rope furnished by the S/R machine manufacturer, unless otherwise recommended by a wire rope or S/R machine manufacturer or a qualified person, based on the actual working condition requirements.

### 13-1.10.4 Sprockets, Pocket Wheels, and Load Chain

(a) Sprocket teeth or chain pockets shall be free from surface defects that could cause chain damage.

(b) Sprockets or pocket wheels carrying chain that can be momentarily unloaded shall be provided with close-fitting guards or other suitable devices to guide the chain back into the teeth or pockets when the load is applied again.

(c) All running chain, sprockets, or pocket wheels should be accessible for lubrication. Permanently lubricated, sealed, or shielded bearings are acceptable.

(d) Provisions shall be made to release the chain freely from the sprocket or pocket wheel to prevent jamming.

### 13-1.10.5 Hoisting Chains

(a) The rated load plus the carriage weight divided by the number of parts of chain supporting the loads shall not exceed 15% of the published ultimate strength of the chain.

(b) The chain anchor shall be designed to develop the ultimate strength of the chain or carry seven times the rated load, whichever is less.



(c) Replacement chain shall be the same size, grade, and construction as the original chain furnished by the S/R machine manufacturer, unless otherwise recommended by a chain or S/R machine manufacturer or a qualified person, based on the actual working condition requirements.

#### 13-1.10.6 Equalizers

If a load is supported by more than one part of rope or chain at each end of the carriage, the tension in the parts shall be equalized.

#### 13-1.10.7 Carriage Free-Fall Stops (Catch Brakes)

(a) Carriages shall be equipped with mechanically applied carriage free-fall stops that are activated by slack or the failure of the rope, chain, or belt, and are capable of stopping and sustaining the carriage with its full load.

(b) Slack or failure of the rope, chain, or belt shall result in removing power from the motor and setting of the brake.

(c) Carriage free-fall stop(s) should be released by raising the carriage by the primary suspension means.

#### 13-1.10.8 Overspeed Device

(a) All S/R machines having carriages on which personnel may ride shall be equipped with an overspeed device on the lowering mode of the hoist motion.

(b) The overspeed device shall operate independently from all other power, drive, and electrical systems.

(c) The overspeed device shall cause free-fall stops to be engaged to stop the carriage when overspeed occurs in the lowering direction.

(d) The overspeed device shall operate whenever the lowering rate exceeds a maximum of 150% of the rated lowering speed.

(e) A switch shall be provided on the overspeed device and operated by the overspeed action of the device. This switch shall, when operated, remove power from the hoisting motor and brake before or at the time of application of the free-fall stops. Switches used to perform this function shall be positively opened, and shall not close until the free-fall stops or sensors are reset to the normal condition.

(f) Each overspeed device shall be marked in a legible and durable manner with letters and figures not less than  $\frac{1}{4}$  in. (6 mm) in height indicating the speed at which the overspeed device is set to operate.

(g) Overspeed devices shall have their means of speed adjustment sealed after the test. Seals shall be of a type that will prevent the readjustment of the overspeed device tripping speed without breaking the seal.

#### 13-1.10.9 Hoisting Belts and Sprockets

(a) Belt and sprocket teeth shall have matched profiles.

(b) The driving sprockets and belt shall provide sufficient tooth engagement to transmit the imposed forces without permanently deforming the teeth.

(c) The minimum diameter of the sprocket and number of teeth shall be per the belt manufacturer's guidelines for the type of belt being used.

(d) Belt sizing for width, tooth size, tooth profile, and belt construction shall be in accordance with the guidelines established by the belt manufacturer. The tooth shear strength, tensile loads, and flexibility limits shall not be exceeded under worst case loading conditions.

(e) Belts shall be selected by the S/R machine manufacturer to operate within the environmental conditions defined by the user including temperature range, humidity, air quality, oil contamination, and other potential airborne particulate or chemicals.

(f) Belt end termination devices shall fit the tooth profile and be applied such that multiple teeth are placed in shear to react against the applied load. The termination device shall clamp the belt to ensure full tooth engagement. The minimum number of teeth engaged with the termination device shall be per the belt manufacturer's guidelines for the load being applied.

### SECTION 13-1.11: TECHNICAL AND SAFETY-RELATED INSTRUCTIONS AND MANUALS

(17)

The manufacturer shall provide instructions and manual for the operation, inspection, testing, maintenance, assembly, and disassembly of the equipment.

(a) The instructions and manuals shall be provided in a language specified by the purchaser at the time of the initial sale by the manufacturer.

(b) Pictograms used to identify controls shall be described in the instructions. The pictograms should comply with ISO 7000, ISO 7296, or another recognized source, if previously defined.

(c) Translations of the original language instructions and manuals shall meet professional translation industry standards, which include, but are not limited to, the following:

(1) translation of the complete paragraph message, instead of word by word

(2) grammatically accurate

(3) preserving the source document content without omitting or expanding the text

(4) translate the terminology accurately

(5) reflect the level of sophistication of the original document

(d) The finished translation shall be verified for compliance with (c)(1) through (c)(5) by a qualified person having an understanding of the technical content of the subject matter.

(e) If the manufacturer no longer exists, it is acceptable to use the instructions and manuals provided with

the machine in place of the original language instructions and manuals for translation. The requirements of (b), (c), and (d) shall apply.

(f) where existing equipment is rebuilt or remanufactured, the provision of instructions and manuals shall be the responsibility of the party performing the remanufacturing or rebuilding.

**13-1.11.1 Translation of Technical and Safety-Related Instructions and Manuals**

The entities performing the operation, use, inspection, testing, maintenance, assembly, and disassembly of the

S/R machines and associated equipment, shall have the instructions and manuals available in a language that their employees can read and understand. If the information is not available in a language understood by their employees, the entities shall obtain a translation of the original manufacturer's instructions and manuals from the manufacturer or from a translation service provider. The translation(s) shall meet the requirements of paras. 13-1.11(c) and (d).

## Chapter 13-2

# Inspection, Testing, and Maintenance

### (17) SECTION 13-2.1: INSPECTION

All inspections shall be performed by a designated person. Any deficiencies identified shall be examined and a determination made by a qualified person as to whether they constitute a hazard, and if so, what additional steps need to be taken to address the hazard. If a hazardous condition is found on an S/R machine or aisle transfer car, the deficient S/R machine or aisle transfer car shall be removed from service until the hazardous condition is corrected. See para. 13-2.3.3 for adjustments and repairs.

#### (17) 13-2.1.1 Inspection Classification

(a) *Initial Inspection.* Prior to initial use, all new, reinstalled, altered, or modified S/R machines or aisle transfer cars shall be inspected to verify compliance with the provision of this Volume.

(b) Inspection procedure for S/R machines or aisle transfer cars is divided into two general classifications based upon the intervals at which inspection should be performed. The intervals in turn are dependent upon the nature of the critical components of the S/R machines or aisle transfer cars and the degree of their exposure to wear, deterioration, or malfunction. The two general classifications are herein designated as *frequent* and *periodic* with respective intervals between inspections as defined below.

(1) *frequent inspection:* visual examinations with records not required

(-a) normal service: monthly

(-b) heavy service: weekly to monthly

(2) *periodic inspection:* visual inspections of apparent external conditions to provide the basis for a continuing evaluation

(-a) normal service (equipment in place): yearly

(-b) heavy service (equipment in place): yearly

#### 13-2.1.2 Frequent Inspection

Items such as the following shall be inspected for defects and damage at intervals as defined in para. 13-2.1.1(b)(1), including observations during operation for any defects and damage that might appear between regular inspections.

(a) *Automatic S/R Machines*

(1) Functional operating mechanisms and sensors shall be checked for proper operation. Operational aids shall be checked for proper operation.

(2) Extreme travel limit sensors shall be checked. Each motion should be run in at slow speeds. Care shall be exercised.

(3) Lines, tanks, valves, pumps, and other parts of air or hydraulic systems shall be inspected for leakage.

(4) Warning devices shall be checked for proper operation.

(5) Other items as detailed in the supplier's maintenance manual shall be considered.

(b) *Cab-Operated S/R Machines and Aisle Transfer Cars.* On cab-operated S/R machines and aisle transfer cars, the following shall be checked, prior to each shift or as defined below:

(1) Functional operating controls shall be checked for proper operation. Operational aids shall be checked for proper operation.

(2) Extreme hoist and travel limit sensors shall be tested. The S/R machine should be run in at slow speed to verify proper operation. Care shall be exercised.

(3) Lines, tanks, valves, pumps, and other parts of air or hydraulic systems shall be inspected for leakage, at the frequency as specified in para. 13-2.1.1(b)(1).

(4) Warning devices shall be checked for proper operation.

(5) Other items as detailed in the supplier's maintenance manual shall be considered.

#### 13-2.1.3 Periodic Inspection

Complete inspections of the S/R machines shall be performed at intervals as defined in para. 13-2.1.1(b)(2). Any deficiencies shall be examined and determination made as to whether they constitute a hazard. These inspections shall include the requirements of para. 13-2.1.2 and, in addition, items such as the following:

(a) deformed, cracked, or corroded members

(b) loose bolts, rivets, and other fasteners

(c) cracked or worn sprockets, pocket wheels, sheaves, and drums

(d) worn, cracked, or distorted parts such as pins, bearings, shafts, gears, rollers, locking, and clamping devices

(e) worn brake system parts, linings, pawls, and ratchets

(f) worn chain drive sprockets, pocket wheels, and chain stretch per Sections 13-2.5 and 13-2.6

(g) electrical apparatus, such as an emergency stop button, shall be functionally tested

(h) overspeed sensors, loss-of-support detection mechanisms, and stopping mechanisms shall be functionally tested

(i) other items as detailed in the supplier's maintenance manual shall be considered

(j) unmarked or illegible operating controls

(k) inoperable or malfunctioning operational aids

**(17) 13-2.1.4 S/R Machines or Aisle Transfer Cars Not in Regular Use**

An S/R machine or aisle transfer car that has been idle for a period of 1 month to 12 months shall be given an inspection conforming to the requirements of para. 13-2.1.2, 13-2.4.1(a), 13-2.5.1, 13-2.6.1(a), or 13-2.7.1(a), as applicable, before being placed into service. An S/R machine or aisle transfer car that has been idle for more than 12 months shall be given an inspection conforming to the requirements of para. 13-2.1.3, 13-2.4.1(b), 13-2.5.1, 13-2.6.1(b), or 13-2.7.1(b), as applicable, before being placed into service.

**(17) 13-2.1.5 Inspection Records**

Dated inspection reports or comparable records shall be made on critical items such as drives, sheaves, chains, ropes, sprockets, shuttles, and safety devices [refer to para. 13-2.1.1(b)(2)]. Records should be kept where they are available for review.

**SECTION 13-2.2: TESTING**

**13-2.2.1 Operational Tests**

(a) Prior to initial use, all new, reinstalled, altered, extensively repaired, or modified S/R machines and aisle transfer cars shall be tested by a qualified person to insure compliance with this Standard including the following functions:

- (1) lifting and lowering
- (2) horizontal travel
- (3) shuttle operation
- (4) limit sensors, locking, and safety devices

(b) The trip setting of the hoist limit sensors shall be determined by tests with an empty carriage traveling at normal speed. The actuating mechanism of the limit sensor shall be located so that it will trip the sensor, under all conditions, in sufficient time to prevent damage to the carriage or hoisting mechanism.

**(17) 13-2.2.2 Rated Load Test**

Prior to initial use, new, extensively repaired, and altered S/R machines shall be tested and inspected in a manual mode by or under the direction of a qualified person and a written report furnished by such person confirming the load rating of the S/R machine. Test loads shall not be more than 125% of the rated load unless otherwise recommended by the manufacturer.

The test reports shall be kept where they are available for review.

**SECTION 13-2.3: MAINTENANCE**

**13-2.3.1 Preventive Maintenance**

**(17)**

(a) A preventive maintenance program shall be established and should be based on the recommendations of the machine manufacturer. Dated records should be kept where they are available for review.

(b) Replacement parts shall be at least equal to the original manufacturer's specifications.

**13-2.3.2 Maintenance Procedure**

(a) Before adjustments and repairs are started on an S/R machine, aisle transfer car, runways, machine aisle conductors, or aisle transfer conductors, the following precautions shall be taken as applicable:

(1) the S/R machine or aisle transfer car to be repaired shall be run to a location where it will cause the least interference with other S/R machines or aisle transfer cars and operations in the area.

(2) transmission of remote command signals to the S/R machine and aisle transfer car shall be prevented. The S/R machine shall be prevented from responding to any remote command signals.

(3) main power disconnect shall be deenergized and locked, tagged, or flagged in the deenergized position unless power is required for maintenance to be performed.

(4) warning or out of order signs shall be placed where readily visible.

(5) where other S/R machines or aisle transfer cars are in operation on the same runway, rail stops or other suitable means shall be provided to prevent interference with the idle S/R machine or aisle transfer car.

(b) After adjustments and repairs have been made, the S/R machine or aisle transfer car shall not be returned to service until all guards have been reinstalled, safety devices reactivated, and maintenance equipment removed.

**13-2.3.3 Adjustments and Repairs**

(a) Any hazardous conditions disclosed by the inspection requirements of Section 13-2.1 shall be corrected before normal operation of the S/R machine or aisle transfer car is resumed. Adjustments and repairs shall be done only by designated personnel.

(b) Adjustments, repairs, and replacements shall be made according to the manufacturer's or a qualified person's recommendations. Special attention should be given to the following:

- (1) all functional operating mechanisms
- (2) limit sensors and safety devices
- (3) control systems
- (4) brakes

(5) all critical parts that are cracked, broken, bent, or excessively worn

(6) pitted or burned electrical contacts should be corrected only by replacement and in sets

(c) In control stations, function and cautionary labels shall be kept legible.

(d) Before repairs involving load bearing members are made, proper identification of the types of material shall be made and appropriate repair procedures shall be followed.

#### 13-2.3.4 Lubrication

(a) All moving parts of the S/R machine or aisle transfer car for which lubrication is specified, including rope and chain, should be regularly lubricated. Lubricating systems should be checked for proper delivery of lubricant. Care should be taken to follow the manufacturer's recommendations concerning the points and frequency of lubrication, maintenance of lubricant levels, and types of lubricant to be used.

(b) Machinery shall be stationary and electrically disconnected as in paras. 13-2.3.2(a)(1) through (a)(4) while lubricants are being applied unless the machine is equipped for automatic or remote lubrication.

### SECTION 13-2.4: ROPE INSPECTION, REPLACEMENT, AND MAINTENANCE

#### (17) 13-2.4.1 Rope Inspection

All inspections shall be performed by a designated person. Any deficiencies identified shall be examined and a determination made by a qualified person as to whether they constitute a hazard, and if so, what additional steps need to be taken to address the hazard.

##### (a) Frequent Inspection

(1) All ropes should be visually inspected at the start of each shift. These visual observations should be concerned with discovering damage, such as listed below, that may be a hazard.

(-a) distortion of the rope such as kinking, crushing, unstranding, birdcaging, main strand displacement, or core protrusion

(-b) general corrosion

(-c) broken or cut strands

(-d) number, distribution, and type of visible broken wires [see paras. 13-2.4.2(b)(1) and 13-2.4.2(b)(2) for further guidance]

(2) When such damage is discovered, the rope shall either be removed from service or given an inspection as detailed in (b).

##### (b) Periodic Inspection

(1) The inspection frequency shall be determined by a qualified person and shall be based on such factors as expected rope life as determined by experience on the particular installation or similar installations, severity of

environment, percentage of capacity lifts, frequency rates of operation, and exposure to shock loads. Inspections need not be at equal calendar intervals and should be more frequent as the rope approaches the end of its useful life.

(2) This inspection shall cover the entire length of rope. The individual outer wires in the strands of the rope shall be visible to this person during the inspection.

(-a) points listed in (a)

(-b) reduction of rope diameter below nominal diameter due to loss of core support, internal or external corrosion, or wear of outside wires

(-c) severely corroded or broken wires at end connections

(-d) severely corroded, cracked, bent, worn, or improperly applied end connections

(3) Special care should be taken when inspecting sections of rapid deterioration such as the following:

(-a) sections in contact with saddles, equalizer sheaves, or other sheaves where rope travel is limited

(-b) sections of the rope at or near terminal ends where corroded or broken wires may protrude

(-c) sections subject to reverse bends

(-d) sections of rope that are normally hidden during visual inspection, such as parts passing over sheaves

(4) In order to establish data as a basis of judging the proper time for replacement, a continuing inspection record should be maintained. This record should cover points of deterioration listed.

#### 13-2.4.2 Rope Replacement

(a) No precise rules can be given for determination of the exact time for rope replacement, since many variable factors are involved. Once a rope reaches any one of the specified removal criteria, it may be allowed to operate to the end of the work shift, based on the judgment of a qualified person. The rope shall be replaced after that work shift, at the end of the day, or at the latest time prior to the equipment being used by the next work shift.

(b) Removal criteria for rope replacement shall be as follows:

(1) in running ropes, 12 randomly distributed broken wires in one lay or 4 broken wires in one strand in one lay

(2) one outer wire broken at the contact point with the core of the rope that has worked its way out of the rope structure and protrudes or loops out from the rope structure

(3) wear of one-third the original diameter of outside individual wires

(4) kinking, crushing, birdcaging, or any other damage resulting in the distortion of the rope structure

(5) evidence of heat damage from any cause

(6) reductions from the nominal diameter greater than 5%

(c) Broken wire removal criteria cited in this Volume apply to wire rope operating on steel sheaves and drums. The user shall contact the sheave, drum, or S/R machine manufacturer, or a qualified person, for broken wire removal criteria for wire ropes operating on sheaves and drums made of material other than steel.

(d) Attention shall be given to end connections. Upon development of two broken wires adjacent to a socketed end connection, the rope should be resocketed or replaced. Resocketing shall not be attempted if the resulting rope length will be insufficient for proper operation.

(e) Replacement rope and connections shall have a strength rating at least as great as the original rope and connections furnished by the S/R machine manufacturer. Any deviation from the original size, grade, or construction shall be specified by a rope manufacturer, the S/R machine manufacturer, or a qualified person.

### 13-2.4.3 Rope Maintenance

(a) Rope should be stored to prevent damage or deterioration.

(b) Unreeling or uncoiling of rope shall be done as recommended by the rope manufacturer and with care to avoid kinking or inducing a twist.

(c) Before cutting a rope, means shall be used to prevent unlaying of the strands.

(d) During installation, care should be observed to avoid dragging the rope in dirt or around objects that will scrape, nick, crush, or induce sharp bends.

(e) Rope should be maintained in a well-lubricated condition. Lubricant applied as part of a maintenance program shall be compatible with the original lubricant. Lubricant applied shall be of the type that does not hinder visual inspection. Those sections of rope that are located over sheaves or otherwise hidden during inspection and maintenance procedures require special attention when lubricating rope. The object of rope lubrication is to reduce internal friction and to prevent corrosion.

## SECTION 13-2.5: ROLLER CHAIN AND LEAF CHAIN INSPECTION, REPLACEMENT, AND MAINTENANCE

### (17) 13-2.5.1 Roller Chain and Leaf Chain Inspection

All inspections shall be performed by a designated person. Any deficiencies identified shall be examined and a determination made by a qualified person as to whether they constitute a hazard, and if so, what additional steps need to be taken to address the hazard. An inspection of hoist chains shall be made at least annually and a dated report of chain condition kept on file.

(a) Check for wear on the sides of the sprocket teeth and on the link plates (for roller chains) or between the

link plates and the inside of the sheave flanges (for leaf chains), either of which would indicate misalignment.

(b) Check for wear on the working faces of the sprocket teeth (roller chain) or face of the sheave wheel (leaf chain). As the drive runs in, these faces should develop a bright, polished appearance. Scratches, grooves, or visible changes in form are signs of trouble, probably caused by sluggish roller action due to lubrication failure. Check the pins and joints for rusting, discoloration, grooving, or galling, indicating a lack of proper lubrication.

(c) Check the actual length of a section of chain when under at least 5% rated load tension, and compare it to the nominal length when new. Any chain elongation in excess of 3% will indicate that the chain itself, and possibly the sprockets or sheave wheels, should be replaced.

(d) Check the chain along with the sprockets or sheave wheels for accumulations of dirt or foreign materials, so as not to inhibit proper lubrication and operation.

### 13-2.5.2 Roller Chain and Leaf Chain Replacement (17)

(a) No precise rules can be given for determination of the exact time for replacement of chain, since many variable factors are involved. Continued use depends largely upon judgment in evaluating remaining strength in a used chain after allowance for deterioration disclosed by inspection. Continued chain operation depends upon this remaining strength.

(b) Conditions such as the following should be a reason for questioning continued use of the chain or increasing the frequency of inspection:

(1) any increase of more than 3% in any given length of a piece of chain under specified test tension, as compared to the nominal length of the chain under the same tension when new

(2) any excessive wear, galling, or other mechanical damage to the chain components

(3) any damage from kinking or twisting that results in the distortion of the chain structure

(4) any excessive signs of rust, discoloration, or wear caused by improper lubrication

(c) Do not insert a new link in a chain that has been appreciably elongated by wear.

(d) Do not install a new chain on badly worn sprockets or sheaves.

(e) Clearances around the chain and other parts should be checked.

(f) In order to establish data as a basis for judging the proper time for replacement, a continuous inspection record shall be maintained. This record shall cover the points of deterioration listed in para. 13-2.5.1.

### 13-2.5.3 Roller Chain and Leaf Chain Maintenance

(a) Chain should be stored to prevent damage or deterioration from moisture or mechanical injury.

(b) During installation, care should be observed to avoid dragging the chain in dirt or around objects that will scrape, twist, foul, or damage the chain in any way.

(c) Chain should be maintained in a well-lubricated condition. It is important that the lubricant applied as part of a maintenance program be compatible with the original lubricant used and have sufficiently low viscosity to reach the internal surfaces, sufficient body to maintain the lubricating film under the bearing pressures, be free from corrosive ingredients, and have the ability to maintain lubricating qualities under conditions of temperature, moisture, etc. The object of proper chain lubrication is to reduce internal friction and to prevent corrosion.

(d) Chain lubrication should follow a periodic schedule based on duty cycle and chain speed. The chain should be inspected at regular intervals to ensure that the frequency of lubrication is sufficient for the application.

## **SECTION 13-2.6: WELDED LINK CHAIN INSPECTION, REPLACEMENT, AND MAINTENANCE**

### **(17) 13-2.6.1 Welded Link Chain Inspection**

All inspections shall be performed by a designated person. Any deficiencies identified shall be examined and a determination made by a qualified person as to whether they constitute a hazard, and if so, what additional steps need to be taken to address the hazard.

(a) *Frequent Inspection.* Chain should be clean to not pose the possibility of carrying deposits into the pocket wheel and sprockets. Examine visually for gouges, nicks, weld splatter, corrosion, and distorted links. If abnormal wear is observed or if evidence of stretching is apparent, the chain should be measured according to the S/R machine manufacturer's instructions. If the instructions are not available, proceed as in (b)(2).

(b) *Periodic Inspection*

(1) Same as (a), except records are kept.

(2) *Wear Measurement*

(a) Select a section of unworn, unstretched length of chain (e.g., at the slack end) that is under at least slight tension. Using a caliper-type gage, measure the outside of any convenient number of links.

(b) Measure the same number of links in the used section under similar conditions of slight load and calculate the percentage increase in length.

(3) Check pocket wheel and sheave wheels for accumulations of dirt or foreign materials, so as not to inhibit proper operation.

(4) Check chain attachment for nicks, gouges, corrosion, and distortion.

### **13-2.6.2 Welded Link Chain Replacement**

(17)

(a) If the used chain exceeds the hoist manufacturer's recommended length or, in the absence of such a recommendation, if the gaged section of used chain is  $2\frac{1}{2}\%$  longer than the unused chain section, replace the chain.

(b) The existence of gouges, nicks, corrosion, weld splatter, or distorted links is reason for questioning chain safety and considering chain replacement. Safety in this respect depends largely upon the use of good judgment in evaluating the degree of deficiency.

(c) Replacement chain shall be the same size, grade, and construction as the original chain furnished by the S/R machine manufacturer, unless otherwise recommended by the S/R machine manufacturer due to actual working conditions.

(d) Load chain links that pass over the load sprocket on edge (alternate to those that lie flat in the pockets) should be installed with the welds away from the center of the sprocket. This precaution is not required on idler sprockets that change the direction but not the tension in the chain.

(e) The chain shall be installed without any twist.

(f) When chain is replaced, disassemble and inspect the mating parts (chain, attachments, sprockets, guides, and stripper) for wear and replace if necessary.

### **13-2.6.3 Welded Link Chain Maintenance**

(a) *Cleaning.* Load chain should be kept clean and free from rust and from any coating deposit that will build up, change its dimensions, reduce flexibility, or form an adhering deposit on the pocket wheels over which it rides. The cleaning process shall not damage these chains.

(b) *Lubrication.* Load chain articulates slowly under high interlink bearing pressures and should be lubricated as specified by the S/R machine manufacturer. In the absence of a recommendation, use anti-weld or EP-type lubricant applied sparingly but frequently since it dissipates during use.

## **SECTION 13-2.7: BELT INSPECTION AND REPLACEMENT**

### **13-2.7.1 Belt Inspection**

(17)

All inspections shall be performed by a designated person. Any deficiencies identified shall be examined and a determination made by a qualified person as to whether they constitute a hazard, and if so, what additional steps need to be taken to address the hazard.

(a) *Frequent Inspection*

(1) Belts should be visually inspected at the start of each shift. Visual inspections should include inspecting the belts for damage. The belt shall be inspected for the following:

(-a) distortion of the belt, such as kinking, crushing, missing teeth, belt displacement, or core protrusion

(-b) general corrosion

(-c) belt damage at the end terminations

(2) When such damage is discovered, the belt shall be removed from service and given an inspection as detailed in (b).

(b) *Periodic Inspection*

(1) The inspection frequency shall be determined by a qualified person and shall be based on S/R machine supplier's or manufacturer's recommendations and such factors as expected belt life as determined by experience on the particular installation or similar installations, severity of environment, percentage of capacity lifts, frequency rates of operation, shock loads, start-up conditions, and braking conditions.

(2) Inspection shall cover examination of the entire length of the belt for signs of corrosion or damage.

(3) The belt tension shall be checked and adjusted as required. The teeth shall fully engage the sprocket so that they do not jump in the sprocket at the prescribed preload designated by the S/R manufacturer. Continually having to tighten the belt may indicate that the belt is permanently elongating and is fatigued and requires replacement.

(4) In order to establish data as a basis of judging the proper time for replacement, a continuing inspection record shall be maintained. The record should identify deficient conditions noted during the inspection.

### **13-2.7.2 Belt Replacement**

(a) The early warning signs of belt fatigue can be difficult to see in a casual inspection. No precise rules

can be given for determination of the exact time for belt replacement, since many variable factors are involved. Once a belt reaches any one of the specified removal criteria, it may be allowed to operate to the end of the work shift, based on the judgment of a qualified person. The belt shall be replaced prior to the equipment being used by the next work shift.

(b) Removal criteria for belt replacement shall be as follows:

(1) evidence of internal rust or other chemical corrosion, noticeable swelling of the belt, peeling of the belt material, or separation of belt material from the wire tensional strands

(2) evidence of broken or worn teeth

(3) damage to the belt including a permanent bend in the belt, cut or tear, and heat damage

(4) physical indications of fatigue in the belt, including cracking or popping noise when flexing the belt, and permanent post-operational elongation of the belt members

(5) evidence of physical damage to the belt end terminations, including missing or deformed belt teeth or damaged or deformed termination attachments

(c) Replacement belt and end terminations shall have a strength rating at least as great as the original belt and connections furnished by the S/R machine manufacturer. Any deviation from the original components shall be specified by the S/R machine manufacturer, supplier, or a qualified person.



## Chapter 13-3 Operation

### SECTION 13-3.1: QUALIFICATIONS FOR AND CONDUCT OF OPERATORS

#### (17) 13-3.1.1 Operators of Operator Ridden S/R Machines or Aisle Transfer Cars

(a) S/R machines or aisle transfer cars shall be operated only by the following qualified personnel:

(1) designated persons.

(2) trainees under the supervision of a designated person. The number of trainees permitted to be supervised by a single designated person, the physical location of the designated person while supervising, and the type of communication required between the designated person and the trainee shall be determined by a qualified person.

(3) maintenance and test personnel, when it is necessary in the performance of their duties.

(4) inspectors (S/R machines or aisle transfer cars).

(b) No one, other than personnel specified in (a), shall enter an S/R machine cab with the exception of persons such as maintenance personnel and supervisors, whose duties require them to do so, and then only in the performance of their duties and with the knowledge of the operator or other designated person.

#### 13-3.1.2 Qualifications for Operators of Operator Ridden S/R Machines or Aisle Transfer Cars

(a) Operators shall be required by the employer to pass a written or oral examination and a practical operating examination unless able to furnish satisfactory evidence of qualifications and experience. Qualification shall be limited to the specific type of equipment for which they are being examined.

(b) Operators and operator trainees shall meet the following physical qualifications:

(1) vision of at least 20/30 Snellen in one eye and 20/50 in the other, with or without corrective lenses

(2) ability to distinguish colors regardless of position of colors, if color differentiation is required for the operation

(3) adequate hearing, with or without a hearing aid, for the specific operation

(4) sufficient strength, endurance, agility, coordination, and speed of reaction to meet the demands of equipment operation

(c) Evidence of physical defects, or emotional instability that could render the operator a hazard to the operator or others, or that in the opinion of the examiner

could interfere with the operator's safe performance may be sufficient cause for disqualification. In such cases, specialized clinical or medical judgments and tests may be required.

(d) Evidence that an operator is subject to seizures or loss of physical control shall be sufficient reason for his disqualification. Specialized medical tests may be required to determine these conditions.

(e) Operator and operator trainees should have normal depth perception, field of vision, reaction time, manual dexterity, coordination, and no tendencies to dizziness or similar undesirable characteristics.

#### 13-3.1.3 Operators and Qualifications for Operators of Remote-Operated S/R Machines and Aisle Transfer Cars

The use of remote control equipment involves such a wide variety of service requirements and conditions that each installation should be carefully analyzed and each operation should be reviewed at least monthly for the first 6 months of the operation to determine whether paras. 13-3.1.1 and 13-3.1.2 should apply, or a special requirement should be made.

#### 13-3.1.4 Conduct of Operators

(17)

(a) The operator shall not engage in any practice that will divert the operator's attention while actually engaged in operating the S/R machine or aisle transfer car.

(b) When physically or otherwise unfit, an operator shall not engage in the operation of the equipment.

(c) Each operator shall be responsible for those operations under the operator's direct control. Whenever there is any doubt as to safety, the operator shall consult with the supervisor before handling the loads.

(d) The operator shall not close the main line disconnect device until certain that no person is on or adjacent to the machine. If there is a warning sign or lock on the device, it shall not be energized until the sign or lock is removed by the person who placed it or a designated person.

(e) The operator shall be familiar with the equipment and its proper care. If adjustments or repairs are necessary, or any defects are known, the operator shall report the same promptly to the designated person who shall be responsible for the safe operation and maintenance repairs of the machine. The operator shall also notify

the next operator of any remaining uncorrected defects upon changing shifts.

(f) Before closing the main line disconnect device, the operator shall see to it that all established startup procedures are followed.

(g) If power goes off during operation, the operator shall immediately implement all shutdown procedures.

(h) Contacts with runway stops or other machines shall be made with extreme caution. The operator shall do so with particular care for the safety of persons on the other machines.

(i) Before any maintenance or inspection work on S/R machines or aisle transfer cars is performed, the operator shall follow the procedures specified in para. 13-2.3.2.

(j) All controllers shall be tested by the operator before beginning a new shift. If any controls do not operate properly, they should be adjusted or repaired before operations are begun.

(k) Persons boarding or leaving the machine should do so only at authorized locations and designated boarding entrances.

## **SECTION 13-3.2: HANDLING THE LOAD**

### **13-3.2.1 Size of Load**

The S/R machine shall not be loaded with a load whose dimensions or weight exceed the design load except for rated load test purposes as provided in para. 13-2.2.2.

### **13-3.2.2 Supporting the Load**

(a) The pallet or container, if used, shall be in good condition and within the tolerances of the design load.

(b) The profile of the load and pallet shall be within the tolerances of the design load.

(c) At input, the loads shall be positioned within the tolerances as specified by the manufacturer.

### **13-3.2.3 Moving the Load**

(a) The operator of an operator ridden S/R machine shall ensure that the load is properly aligned on the carriage.

(b) The load sizing station(s), if provided, for an automatic S/R machine shall determine that the load is dimensionally acceptable.

(c) The user of the automatic S/R machine system shall ensure the load is stable.

(d) The operator shall lift, lower, or travel while a person is on the carriage outside the cab only when necessary to perform maintenance, inspection, or inventory checks and only under the following conditions:

(1) Any person on the carriage shall be secured with fall protection equipment complying with ASSE Z359.1.

(2) The controls shall be operated by a qualified operator.

(e) The operator shall avoid carrying loads over people.

## **SECTION 13-3.3: MISCELLANEOUS**

### **13-3.3.1 Using Ladders**

(a) Hands shall be free from encumbrances while personnel are using ladders.

(b) Articles that are too large to be carried in pockets or tool belts shall not be hand carried.

### **13-3.3.2 Cabs**

(a) Necessary clothing and personal belongings shall be stored in such a manner as to not interfere with access or operation.

(b) Tools, oil cans, waste, extra fuses, and other necessary articles shall be stored in the tool box and shall not be permitted to lie loose in or about the cab.

### **13-3.3.3 Fire Extinguishers**

Operators shall be familiar with the location, operation, and care of fire extinguishers provided.

### **13-3.3.4 Personnel Access**

(a) Access to machine aisles by unauthorized personnel should be avoided.

(b) If necessary for personnel to be in aisles or runways, procedures for such entry should be established and carefully followed.

(c) In cases such as in (b), warning signs shall not be obstructed or removed, nor shall interlocks, where provided, be bypassed.

### **13-3.3.5 General Housekeeping**

Good housekeeping practices are important to safe operation of the equipment.

INTENTIONALLY LEFT BLANK

## ASME Services

ASME is committed to developing and delivering technical information. At ASME's Customer Care, we make every effort to answer your questions and expedite your orders. Our representatives are ready to assist you in the following areas:

ASME Press  
*Codes & Standards*  
Credit Card Orders  
IMEchE Publications  
Meetings & Conferences  
Member Dues Status

Member Services & Benefits  
Other ASME Programs  
Payment Inquiries  
Professional Development  
Short Courses  
Publications

Public Information  
Self-Study Courses  
Shipping Information  
Subscriptions/Journals/Magazines  
Symposia Volumes  
Technical Papers

### How can you reach us? It's easier than ever!

There are four options for making inquiries\* or placing orders. Simply mail, phone, fax, or E-mail us and a Customer Care representative will handle your request.

*Mail*  
**ASME**  
150 Clove Road, 6th Floor  
Little Falls, New Jersey  
07424-2139

*Call Toll Free*  
**US & Canada:** 800-THE-ASME  
(800-843-2763)  
**Mexico:** 95-800-THE-ASME  
(95-800-843-2763)

*Fax—24 hours*  
973-882-1717  
973-882-5155

*E-Mail—24 hours*  
customercare@asme.org

\* Customer Care staff are not permitted to answer inquiries about the technical content of this code or standard. Information as to whether or not technical inquiries are issued to this code or standard is shown on the copyright page. All technical inquiries must be submitted in writing to the staff secretary. Additional procedures for inquiries may be listed within.

# ASME B30.13-2017

ISBN 978-0-7918-7151-5

