

RRC Study Text

**NEBOSH**

International General Certificate in  
Occupational Health and Safety

**Unit IG2: Risk Assessment**

September 2019





# NEBOSH INTERNATIONAL GENERAL CERTIFICATE IN OCCUPATIONAL HEALTH AND SAFETY UNIT IG2

Introduction to the Certificate Course

---

Introduction to Unit IG2

---

Element 5: Physical and Psychological Health

---

Element 6: Musculoskeletal Health

---

Element 7: Chemical and Biological Agents

---

Element 8: General Workplace Issues

---

Element 9: Work Equipment

---

Element 10: Fire

---

Element 11: Electricity

---

Unit IG2: Final Reminders

---

Suggested Answers to Study Questions

---

## Contributor

---

**Dr J Phelpstead**, BSc, PhD, CMIOSH

© RRC International

All rights reserved. RRC International is the trading name of The Rapid Results College Limited, Tuition House, 27-37 St George's Road, London, SW19 4DS, UK.

These materials are provided under licence from The Rapid Results College Limited. No part of this publication may be reproduced, stored in a retrieval system, or transmitted in any form, or by any means, electronic, electrostatic, mechanical, photocopied or otherwise, without the express permission in writing from RRC Publishing.

For information on all RRC publications and training courses, visit: [www.rrc.co.uk](http://www.rrc.co.uk)

RRC: IG2.1

ISBN for this volume: 978-1-912652-27-3  
First edition September 2019

## ACKNOWLEDGMENTS

RRC International would like to thank the National Examination Board in Occupational Safety and Health (NEBOSH) for their co-operation in allowing us to reproduce extracts from their syllabus guides.

This publication contains public sector information published by the Health and Safety Executive and licensed under the Open Government Licence v.3 ([www.nationalarchives.gov.uk/doc/open-government-licence/version/3](http://www.nationalarchives.gov.uk/doc/open-government-licence/version/3)).

Every effort has been made to trace copyright material and obtain permission to reproduce it. If there are any errors or omissions, RRC would welcome notification so that corrections may be incorporated in future reprints or editions of this material.

Whilst the information in this book is believed to be true and accurate at the date of going to press, neither the author nor the publisher can accept any legal responsibility or liability for any errors or omissions that may be made.

## Unit IG2

<b>Introduction to the Certificate Course</b>	<b>1</b>
---	----------

<b>Introduction to Unit IG2</b>	<b>6</b>
---------------------------------	----------

## Element 5: Physical and Psychological Health

<b>Noise</b>	<b>5-3</b>
--------------	------------

The Effects of Exposure to Noise	5-3
Terminology	5-5
The Assessment of Noise Exposure	5-5
Noise Exposure Standards	5-6
Basic Noise Control Measures	5-8
Hearing Protection	5-9
The Role of Health Surveillance	5-11

<b>Vibration</b>	<b>5-13</b>
------------------	-------------

Introduction to Vibration	5-13
Health Effects of Exposure to Vibration	5-13
The Assessment of Vibration Exposure	5-14
Vibration Exposure Standards	5-15
Basic Vibration Control Measures	5-16
Role of Health Surveillance	5-17

<b>Radiation</b>	<b>5-18</b>
------------------	-------------

The Types of Radiation and their Health Effects	5-18
Non-Ionising Radiation	5-18
Ionising Radiation	5-20
Basic Radiation Protection Strategies	5-23
Role of Monitoring and Health Surveillance	5-23

<b>Mental Ill Health</b>	<b>5-25</b>
--------------------------	-------------

The Prevalence of Mental Ill Health Within the Workplace	5-25
Common Types of Mental Ill Health	5-26
Causes of Work-Related Mental Ill Health	5-28
Control Measures	5-29

<b>Work-Related Violence</b>	<b>5-31</b>
------------------------------	-------------

Risk Factors and Control Measures	5-31
-----------------------------------	------

<b>Substance Abuse at Work</b>	<b>5-34</b>
--------------------------------	-------------

Types of Substances Abused at Work	5-34
Risks to Health and Safety from Substance Abuse at Work	5-34
Control Measures to Reduce Risks from Substance Abuse at Work	5-35

<b>Summary</b>	<b>5-36</b>
----------------	-------------

<b>Practical Assessment Guidance</b>	<b>5-37</b>
--------------------------------------	-------------

## Element 6: Musculoskeletal Health

<b>Work-Related Upper Limb Disorders</b>	<b>6-3</b>
Musculoskeletal Disorders and Work-Related Upper Limb Disorders	6-3
Musculoskeletal Disorder Risk Factors	6-4
Managing the Risk of Musculoskeletal Disorders	6-5
A Typical Example: Display Screen Equipment	6-6
<b>Manual Handling</b>	<b>6-9</b>
Common Types of Manual Handling Injury	6-9
Good Handling Technique	6-10
Controlling Manual Handling Risk	6-10
<b>Load-Handling Equipment</b>	<b>6-15</b>
Hazards and Safe Use of Manually Operated Load-Handling Equipment	6-15
Powered Load-Handling Equipment	6-17
Requirements for Safe Lifting Operations	6-23
Requirements for Statutory Examination of Lifting Equipment	6-24
<b>Summary</b>	<b>6-26</b>
<b>Practical Assessment Guidance</b>	<b>6-27</b>

## Element 7: Chemical and Biological Agents

<b>Forms of, Classification of and Health Risks from Hazardous Substances</b>	<b>7-3</b>
Introduction to Health Risks from Hazardous Substances	7-3
Forms of Chemical Agents	7-3
Forms of Biological Agents	7-4
Acute and Chronic Health Effects	7-4
Classification of Chemicals Hazardous to Health	7-4
<b>Assessment of Health Risks</b>	<b>7-7</b>
Routes of Entry	7-7
Defence Mechanisms	7-8
Assessment of Health Risks	7-10
Product Information	7-11
Hazardous Substance Monitoring	7-13
<b>Occupational Exposure Limits</b>	<b>7-16</b>
Occupational Exposure Limits	7-16
<b>Control Measures</b>	<b>7-20</b>
The Need to Prevent or Control Exposure	7-20
Principles of Good Practice	7-20
The Practical Control of Exposure	7-21
Further Control of Carcinogens, Mutagens and Asthmagens	7-30
<b>Specific Agents</b>	<b>7-32</b>
Asbestos	7-32
Blood-Borne Viruses	7-34
Carbon Monoxide	7-34
Cement	7-35
Legionella Bacteria	7-36
Leptospira Bacteria	7-37
Silica	7-37
Wood Dust	7-38
<b>Summary</b>	<b>7-40</b>
<b>Practical Assessment Guidance</b>	<b>7-41</b>

## Element 8: General Workplace Issues

<b>Health, Welfare and Work Environment Requirements</b>	<b>8-3</b>
Welfare Provision	8-3
Work Environment Requirements	8-4
Exposure to Extremes of Temperature	8-4
<b>Working at Height</b>	<b>8-7</b>
Introduction to Working at Height	8-7
Risk Factors for Work at Height	8-8
Controlling the Risks of Work at Height	8-10
Avoiding Work at Height	8-10
Preventing Falls and Falling Materials	8-11
Minimising Distance and Consequences of a Fall	8-14
Provision of Equipment, Training and Instruction	8-14
Safe Working Practices for Access Equipment	8-15
<b>Working in Confined Spaces</b>	<b>8-24</b>
Introduction to Confined Spaces	8-24
Factors to be Assessed	8-25
<b>Lone Working</b>	<b>8-29</b>
Introduction to Lone Working	8-29
Risk Assessment Factors for Lone Working	8-29
Safe System of Work for Lone Working	8-30
<b>Slips and Trips</b>	<b>8-32</b>
Common Slipping and Tripping Hazards	8-32
Control Measures for Slips and Trips	8-33
<b>Safe Movement of People and Vehicles in the Workplace</b>	<b>8-37</b>
Risks Associated with Workplace Transport Operations	8-37
Workplace Transport Control Measures	8-40
<b>Work-Related Driving</b>	<b>8-46</b>
Managing Work-Related Road Safety	8-46
Risk Assessment Factors	8-47
Evaluating the Risks	8-48
Control Measures	8-48
Hazards of Electric and Hybrid Vehicles	8-51
<b>Summary</b>	<b>8-52</b>
<b>Practical Assessment Guidance</b>	<b>8-54</b>

## Element 9: Work Equipment

<b>General Requirements for Work Equipment</b>	<b>9-3</b>
Types of Work Equipment	9-3
<b>Hand Tools and Portable Power Tools</b>	<b>9-9</b>
Hazards and Controls for Hand Tools	9-9
Hazards and Controls for Portable Power Tools	9-10
<b>Machinery Hazards</b>	<b>9-12</b>
Mechanical and Non-Mechanical Hazards	9-12
<b>Control Measures for Machinery Hazards</b>	<b>9-17</b>
Machinery Safeguarding Methods	9-17
Specific Machinery Examples – Hazards and Control Measures	9-24
Requirements for Guards and Safety Devices	9-29
<b>Summary</b>	<b>9-31</b>
<b>Practical Assessment Guidance</b>	<b>9-32</b>

## Element 10: Fire

<b>Fire Initiation, Classification and Spread</b>	<b>10-3</b>
Principles of Fire	10-3
Classification of Fires	10-3
Principles of Heat Transmission and Fire Spread	10-4
Common Causes and Consequences of Fires in Workplaces	10-5
<b>Preventing Fire and Fire Spread</b>	<b>10-7</b>
Control Measures to Minimise the Risk of Fire in a Workplace	10-7
Storage of Flammable Liquids	10-11
Structural Measures for Preventing the Spread of Fire and Smoke	10-13
<b>Fire Alarms and Fire-Fighting</b>	<b>10-16</b>
Fire Detection and Alarm Systems	10-16
Portable Fire-Fighting Equipment	10-17
Access for Fire and Rescue Services	10-20
<b>Fire Evacuation</b>	<b>10-21</b>
Means of Escape	10-21
Emergency Evacuation Procedures	10-24
<b>Summary</b>	<b>10-29</b>
<b>Practical Assessment Guidance</b>	<b>10-30</b>

## Element 11: Electricity

<b>The Hazards and Risks of Electricity</b>	<b>11-3</b>
Introduction to Electricity	11-3
The Hazards and Risks of Electricity	11-4
Dangerous Activities	11-7
<b>Control Measures</b>	<b>11-10</b>
Introduction to Control Measures	11-10
Protective Systems and Devices	11-11
Competent Persons	11-14
Use of Safe Systems of Work	11-15
Emergency Procedures Following an Electrical Incident	11-16
Inspection and Maintenance Strategies	11-17
<b>Summary</b>	<b>11-22</b>
<b>Practical Assessment Guidance</b>	<b>11-23</b>

## Unit IG2: Final Reminders

### Suggested Answers to Study Questions

# Introduction to the Certificate Course

## Course Structure

This study text has been designed to provide you with the core knowledge needed to successfully complete Unit 2 of the NEBOSH International General Certificate in Occupational Health and Safety, as well as providing a useful overview of the practical control of various health and safety issues in the workplace. It follows the structure and content of the NEBOSH syllabus.

### MORE...

For more detailed information about the syllabus, visit the NEBOSH website:

[www.nebosh.org.uk](http://www.nebosh.org.uk)

NEBOSH International General Certificate in Occupational Health and Safety	
<b>Unit IG1: Management of Health and Safety – Assessed by the Question Paper</b>	
Element 1	Why We Should Manage Workplace Health and Safety
Element 2	How Health and Safety Management Systems Work and What They Look Like
Element 3	Managing Risk – Understanding People and Processes
Element 4	Health and Safety Monitoring and Measuring
<b>Unit IG2: Risk Assessment – Assessed by the Practical Assessment</b>	
Element 5	Physical and Psychological Health
Element 6	Musculoskeletal Health
Element 7	Chemical and Biological Agents
Element 8	General Workplace Issues
Element 9	Work Equipment
Element 10	Fire
Element 11	Electricity



### The Assessments

To complete the qualification, you need to pass one formal written question paper (the Unit IG1 exam) and a practical assessment.

The formal written exam tests knowledge covered in Elements 1 to 4 (Unit IG1). It does not test information covered in Elements 5 to 11 (Unit IG2).

The written exam is 2 hours long and consists of 11 compulsory questions – each of which requires a full written answer. Further information and help on the written exam is given in the Unit IG1 study text.

The practical assessment tests knowledge covered in Elements 5 to 11. This requires you to carry out a risk assessment in the workplace.

Further information and help on the practical assessment is given in this study text in the Introduction to Unit IG2, the Practical Assessment Guidance sections at the end of Elements 5 to 11 and in the Unit IG2: Final Reminders section.

#### HINTS AND TIPS

As you work your way through this book, always remember to relate your own experiences in the workplace to the topics you study. An appreciation of the practical application and significance of health and safety will help you understand the topics.

## Learning Outcomes and Assessment Criteria

The learning outcomes and assessment criteria for the course are set out below.

Learning Outcome The learner will be able to:	Related Content	Assessment Criteria	Assessment (QP = Question Paper, P = Practical)
Justify health and safety improvements using moral, financial and legal arguments.	1.1–1.2	1.1 Discuss the moral, financial and legal reasons for managing health and safety in the workplace.  1.2 Explain how the law works and the consequences of non-compliance.	QP
Advise on the main duties for health and safety in the workplace and help their organisation manage contractors.	1.3	1.3 Summarise the main health and safety duties of different groups of people at work and explain how contractors should be selected, monitored and managed.	QP
Work within a health and safety management system, recognising what effective general policy, organisation and arrangements should look like.	2.1–2.2	2.1 Give an overview of the elements of a health and safety management system and the benefits of having a formal/certified system.  2.2 Discuss the main ingredients of health and safety management systems that make it effective – general policy, organisation, arrangements.	QP
Positively influence health and safety culture and behaviour to improve performance in their organisation.	3.1–3.3	3.1 Describe the concept of health and safety culture and how it influences performance.  3.2 Summarise how health and safety culture at work can be improved.  3.3 Summarise the human factors which positively or negatively influence behaviour at work in a way that can affect health and safety.	QP
Do a general risk assessment in their own workplace – profiling and prioritising risks, inspecting the workplace, recognising a range of common hazards, evaluating risks (taking account of current controls), recommending further control measures, planning actions.	3.4  5–11	3.4 Explain the principles of the risk assessment process.  5–11 Produce a risk assessment of a workplace which considers a wide range of identified hazards (drawn from Elements 5–11) and meets best practice standards ('suitable and sufficient').	QP  P

Learning Outcome The learner will be able to:	Related Content	Assessment Criteria	Assessment (QP = Question Paper, P = Practical)
Recognise workplace changes that have significant health and safety impacts and effective ways to minimise those impacts.	3.5	3.5 Discuss typical workplace changes that have significant health and safety impacts and ways to minimise those impacts.	QP
Develop basic safe systems of work (including taking account of typical emergencies) and knowing when to use permit-to-work systems for special risks.	3.6–3.8	3.6 Describe what to consider when developing and implementing a safe system of work for general activities.  3.7 Explain the role, function and operation of a permit-to-work system.  3.8 Discuss typical emergency procedures (including training and testing) and how to decide what level of first aid is needed in the workplace.	QP
Take part in incident investigations.	4.2	4.2 Explain why and how incidents should be investigated, recorded and reported.	QP
Help their employer to check their management system effectiveness – through monitoring, audits and reviews.	4.1, 4.3–4.4	4.1 Discuss common methods and indicators used to monitor the effectiveness of management systems.  4.3 Explain what an audit is and why and how they are used to evaluate a management system.  4.4 Explain why and how regular reviews of health and safety performance are needed.	QP

These learning outcomes and assessment criteria are published by NEBOSH in the syllabus guide for the course.

## Keeping Yourself Up to Date

The field of health and safety is constantly evolving and, as such, it will be necessary for you to keep up to date with changing legislation and best practice.

RRC International publishes updates to all its course materials via a quarterly newsletter, which alerts students to key changes in legislation, best practice and other information pertinent to current courses.

Please visit [www.rrc.co.uk/news/newsletters.aspx](http://www.rrc.co.uk/news/newsletters.aspx) to access these updates.

## Other Publications

### Study Aids

- NEBOSH International General Certificate in Occupational Health and Safety Revision Guide
- RRC Health and Safety Law Step Notes
- RRC Occupational Health and Hygiene Step Notes
- RRC Quality Management Step Notes
- RRC Environmental Step Notes

### Further Your Studies

- NEBOSH International Diploma in Occupational Safety and Health – Unit IA: Managing Health and Safety
- NEBOSH International Diploma in Occupational Safety and Health – Unit IB: Hazardous Substances/Agents
- NEBOSH International Diploma in Occupational Safety and Health – Unit IC: Workplace and Work Equipment Safety

RRC International is continually adding to its range of publications. Visit [www.rrc.co.uk/publications.aspx](http://www.rrc.co.uk/publications.aspx) for a full range of current titles.

## Introduction to Unit IG2

Welcome to the second part of your NEBOSH Certificate course.

Unit IG2 has seven chapters or 'elements':

- **Element 5:** contains an explanation of six physical and psychological health hazards: noise, vibration, radiation, mental ill health, work-related violence and substance abuse.
- **Element 6:** looks at musculoskeletal health and covers the topics of work-related upper limb disorders, manual handling and mechanical load-handling equipment.
- **Element 7:** deals with chemical and biological agents.
- **Element 8:** contains an explanation of a wide range of general workplace issues such as welfare provision, working at height, confined space entry, lone working, slips and trips, safe movement of pedestrians and vehicles in the workplace, and work-related driving.
- **Element 9:** focuses on work equipment and the hazards and control measures associated with simple hand tools, power tools and machinery.
- **Element 10:** looks at fire safety and covers basic fire prevention, the control of fire spread, fire alarm systems and fire evacuation.
- **Element 11:** deals with the hazards and risks of electricity, and typical workplace control measures.

The common theme that runs through these elements is that they deal with specific hazards or hazard groups and the practical control of the risks created by these hazards. They do not deal with management issues, such as accident reporting or auditing, which is the focus of Unit IG1.

These last seven elements of the course are assessed by a practical assessment.

### Legal Standards

This book has been written to cover content for the International General Certificate courses. Because there are no truly universal global legal standards that will apply in all national legislative frameworks, the book makes frequent use of UK legal standards (i.e. those that apply in Great Britain and Northern Ireland), as these often represent best practice. They also normally reflect the legal standards to be found in other European countries. It is not possible or desirable to include all of the specific technical legal standards that apply in various countries around the world. However, it is useful to recognise that the International Labour Organization (ILO) has established Conventions and Recommendations on many of the topics and issues dealt with.

A Legal Standards box is included at the end of most sections of the book. These highlight the relevant ILO Conventions and Recommendations.

The box looks like this:

Legal Standards
<ul style="list-style-type: none"> <li>• ILO C120 – Hygiene (Commerce and Offices), Convention, 1964 (No. 120).</li> <li>• ILO R120 – Hygiene (Commerce and Offices), Recommendation, 1964 (No. 120).</li> <li>• ILO R102 – Welfare Facilities Recommendation, 1956 (No. 102).</li> </ul>

Hopefully these legal standards references will help you recognise and find the law relevant to specific topics and issues. This might be particularly useful when completing the practical assessment.

## Study Skills

There is no exam for the Unit IG2 – instead it is assessed by a practical assessment. To successfully complete this assessment, you need to read and understand all of the information in Unit IG2. This will help you conduct appropriate research in your workplace so that you can do the risk assessment exercise required. It will also help you to get your facts and your references right in the assessment. These are important points to show to the examiner.

Because there is no exam for Unit IG2, it does not make sense to study Elements 5 to 11 in the same way that you studied the first four elements. You do not need to take notes, make study aids or revise in the same way.

## The Practical Assessment

There are two parts to the formal assessment for the Certificate course: one written exam and a practical assessment.

The practical assessment tests knowledge covered in Elements 5–11 (Unit IG2 covered by this study text). It does not test knowledge of Elements 1–4 (Unit IG1 covered by the first study text) except that it will require you to carry out a risk assessment (which is covered in Element 3 of Unit IG1). But don't worry; detailed guidance is available and you do not have to remember key information from Element 3 for this assessment.

The practical assessment requires you to carry out a risk assessment on a wide range of hazards from several different hazard categories. For each hazard, you will have to identify the nature of the hazard(s) presented, the people who might be harmed and how, the current control measures in place and any further control measures necessary to adequately manage the risks.

You will have to develop action plans to address all of the additional control measures that you have identified in that assessment. You will then have to prioritise three actions that you think are the most urgent and justify your choices.

There are standard forms that you will be required to fill in as you complete each step of the process above.

Unlike the exam, you will not be awarded a specific percentage score for each part of the practical assessment. Instead, the risk assessment is given a 'pass' or a 'referral' depending on whether it meets the required standard or not.

You must achieve a pass in the practical assessment in order to achieve the Certificate qualification.

If you do not achieve a pass, you will have to retake the practical assessment. You have to achieve a pass in the practical assessment within five years of achieving a pass in the Unit IG1 exam. You can retake the practical as many times as you need to within this five-year timescale.

Don't worry about the details of the practical assessment for now. It is simply worth bearing in mind, as you read through your Unit IG2 course materials and study the various topics and ideas, that there is a risk assessment at the end. You can start work on this assessment at any time and continue to work on it as you go through the topics.

More information and help on the practical assessment is presented in the Practical Assessment Guidance sections at the end of Elements 5–11 and in the Final Reminders section at the end of the study text.

Enjoy Unit IG2 of the course!



# Physical and Psychological Health



## Learning Objectives

Once you've studied this element, you should be able to:

- 1 Describe the health effects associated with exposure to noise and appropriate control measures.
- 2 Describe the health effects associated with exposure to vibration and appropriate control measures.
- 3 Describe the health effects associated with ionising and non-ionising radiation and appropriate control measures.
- 4 Describe the causes of work-related mental ill health and how the condition can be managed.
- 5 Describe the risk factors and appropriate controls for violence at work.
- 6 Describe the effects of substance abuse on health and safety at work and control measures to reduce such risks.

<b>Noise</b>	<b>5-3</b>
The Effects of Exposure to Noise	5-3
Terminology	5-5
The Assessment of Noise Exposure	5-5
Noise Exposure Standards	5-6
Basic Noise Control Measures	5-8
Hearing Protection	5-9
The Role of Health Surveillance	5-11
<b>Vibration</b>	<b>5-13</b>
Introduction to Vibration	5-13
Health Effects of Exposure to Vibration	5-13
The Assessment of Vibration Exposure	5-14
Vibration Exposure Standards	5-15
Basic Vibration Control Measures	5-16
Role of Health Surveillance	5-17
<b>Radiation</b>	<b>5-18</b>
The Types of Radiation and their Health Effects	5-18
Non-Ionising Radiation	5-18
Ionising Radiation	5-20
Basic Radiation Protection Strategies	5-23
Role of Monitoring and Health Surveillance	5-23
<b>Mental Ill Health</b>	<b>5-25</b>
The Prevalence of Mental Ill Health Within the Workplace	5-25
Common Types of Mental Ill Health	5-26
Causes of Work-Related Mental Ill Health	5-28
Control Measures	5-29
<b>Work-Related Violence</b>	<b>5-31</b>
Risk Factors and Control Measures	5-31
<b>Substance Abuse at Work</b>	<b>5-34</b>
Types of Substances Abused at Work	5-34
Risks to Health and Safety from Substance Abuse at Work	5-34
Control Measures to Reduce Risks from Substance Abuse at Work	5-35
<b>Summary</b>	<b>5-36</b>
<b>Practical Assessment Guidance</b>	<b>5-37</b>

# Noise

## IN THIS SECTION...

- Exposure to excessive noise causes Noise-Induced Hearing Loss (NIHL) as well as other health and safety risks.
- Noise exposure standards are based on a worker's daily personal noise exposure. An exposure of 85 dB(A) over an eight-hour work shift is generally considered to be the upper exposure standard at which action has to be taken to reduce exposure.
- Noise exposure should be assessed by undertaking a noise survey using a sound level meter.
- Control of exposure to noise can be achieved by:
  - Reducing the noise at source: by elimination, substitution, maintenance, damping and silencing.
  - Interrupting the pathway from source to receiver: by isolation and absorption.
  - Protecting the receiver: by providing an acoustic haven or Personal Protective Equipment (PPE).
- There are two types of hearing protection: ear defenders and ear plugs. Both types have advantages and limitations.
- Health surveillance in the form of hearing tests (audiometry) is required where employee exposure is above the upper exposure action value.

## The Effects of Exposure to Noise

There are many occupations where there is a risk of exposure to excessive noise. Examples include:

- Construction workers – as a result of plant and machinery operation, such as concrete breakers.
- Uniformed services – such as army personnel exposed to noise from small arms and artillery.
- Entertainment sector workers – such as night club staff exposed to loud music.
- Manufacturing sector workers – exposed to industrial machinery noise.
- Call centre staff – exposed to loud noise and acoustic shock from the use of headsets.

There are many health and safety issues associated with noise in the workplace.

## Physical Effects

Physical effects include:

- Temporary reduction in hearing sensitivity as a result of short-duration exposure to excessively loud noise (e.g. muffled hearing after a loud concert).
- Noise-Induced Hearing Loss (NIHL) – permanent, progressive loss of hearing as a result of repeated exposure to excessively loud noise.
- Tinnitus – persistent ringing in the ears as a result of repeated exposure to excessively loud noise. This may be temporary or permanent.



Exposure to excessively loud noise can have a range of effects

- Inability to hear:
  - hazards such as vehicles;
  - alarms and warning sirens;
  - conversation and spoken instructions;
 as a result of background noise.

## Psychological Effects

Psychological effects include:

- Stress effects – caused by irritating nuisance/background noise.
- Difficulty concentrating and an increase in errors caused by nuisance/background noise.

Perhaps the most serious effect is **Noise-Induced Hearing Loss (NIHL)** (or industrial deafness). This is usually caused by long-term, repeated exposure to excessively loud noise, but it can also be caused by one-off exposure to extremely loud noise.

When people are exposed to excessively loud noise, the hearing mechanism itself is damaged. The hearing mechanism transmits noise from the outside environment through the outer and middle ear to the inner ear (the transmission route is: ear canal, eardrum, hammer, anvil, stirrup, cochlea). Microscopically small sensory hairs in the cochlea in the inner ear then detect the noise and send nerve impulses to the brain. Exposure to excessively loud noise disturbs and destroys these microscopically small hairs.

One-off exposure to high-noise levels (e.g. four hours of work in a high-noise area) will probably cause a temporary loss of hearing sensitivity (called '**temporary threshold shift**') and temporary ringing in the ears (**tinnitus**). The microscopically small hairs have been disturbed, but not damaged beyond repair. Repeated exposures result in **permanent threshold shift** – irreparable damage because the sensory hairs are parts of nerve cells that do not regenerate. This is **NIHL**.

This hearing loss does not normally occur quickly, but over years as noise exposure continues. The damage is progressive and irreversible – once it starts, any further exposure to excessive noise will result in further damage.

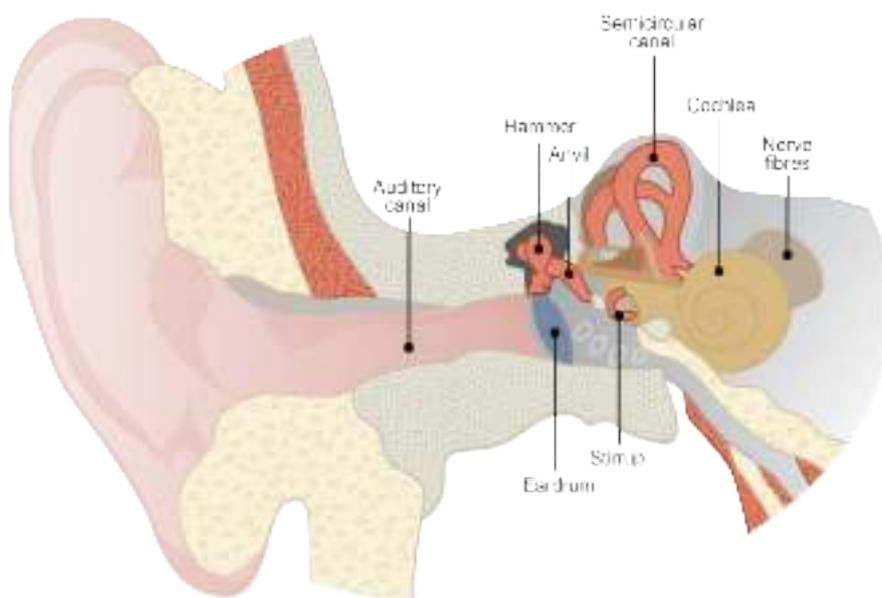

Diagram showing the internal parts of the ear

## Terminology

The following basic terminology is used in the measurement and assessment of noise exposures in the workplace:

- **Sound pressure** – the air pressure of sound waves moving through the air. This pressure is measured using the decibel (dB) scale.
- **Intensity** – a measure of the energy carried by sound pressure waves moving through the air (which we subjectively call the 'volume' or 'loudness').
- **Decibel (dB)** – the unit of sound pressure level. The decibel scale is a logarithmic scale; this means that relatively small increases in decibel value actually represent very large increases in intensity. For example, an increase of just 3 dB represents a doubling of sound intensity.
- **Frequency** – a measure of the number of sound pressure waves that pass a fixed point in one second (the 'pitch'); the unit is the hertz (Hz). The human ear is sensitive to noise across a wide range of frequencies: from 20Hz (very low frequencies – bass) to 20,000Hz (very high frequencies – treble (high pitch)). Equally, there are some sounds the human ear can't hear as they are outside of this frequency range (e.g. a high-pitched whistle).
- **A-weighting** – during noise assessment, A-weighting is applied to the decibel values at different frequencies to give a sound pressure level expressed as **dB(A)**. This A-weighting converts the decibel value to take into account the sensitivity of the human ear across a range of frequencies. In other words, it is the decibel value corrected for the sensitivity of the human ear.
- **C-weighting** – during noise assessment, C-weighting may be applied to the decibel values at different frequencies to give a sound pressure level expressed as **dB(C)**. This C-weighting gives a more accurate reading for **impulse** noise – single loud bangs that would not be properly recorded using the dB(A) scale.

Typical decibel levels associated with different noise sources

Measurement in dB(A)	Sound
0	The faintest audible sounds
20–30	A quiet library
50–60	A conversation
65–75	A loud radio
90–100	A power drill
140	A jet aircraft taking off 25m away

## The Assessment of Noise Exposure

Damage to hearing in the form of NIHL and tinnitus is dependent on the **dose** of noise that a person receives. This dose of noise is determined by the sound pressure level that the person is exposed to in combination with the duration of time that they are exposed to it for.

In order to work out what a worker's exposure to noise is in the workplace, and whether or not the dose of noise that they have been exposed to is excessive, employers must undertake some form of technical **noise assessment**. In most countries, this noise assessment requirement is written into legal standards. Though the technical details vary, it is easiest to demonstrate the general principle by considering one regulatory regime: the one used in the UK and the EU.

The **Control of Noise at Work Regulations 2005** state that noise assessments are required where there is likely to be significant exposure to noise. Simple hearing checks can be used to estimate noise levels. If normal conversation cannot be heard at a distance of one metre from the speaker then the noise levels are likely to be in the region of 85 dB(A).

Where a noise assessment is needed, some form of noise measurement will probably have to be carried out. Before this is done, information has to be obtained from the workplace (e.g. about the noise sources in the workplace and shift patterns). This background information can then be used to target the survey and can help in the interpretation of results.

Different types of sound level meter (noise meter) are used to undertake noise measurements. Because these are scientific instruments they have to be calibrated before use.

The results of a noise survey need to be interpreted to give an accurate estimate of workers' exposures. These exposures can then be compared to the legal standards and any necessary action identified.

Noise measurement and assessment is a complex topic that should only be undertaken by a competent person.



A simple sound level meter

## Noise Exposure Standards

The **Control of Noise at Work Regulations 2005** recognise exposure standards that have been set on the basis that the amount of damage done to the ear is dependent on the amount of energy absorbed by the inner ear. This is determined by two factors:

- **Noise level** (measured in dB(A)).
- **Duration of exposure** (in hours and minutes).

These two factors determine the dose of noise absorbed (a similar principle to hazardous substances and OELs/WELs outlined in Element 7). So, when undertaking a noise assessment, it is necessary to measure a worker's actual exposure to noise (which will fluctuate) and then to calculate what the equivalent eight-hour exposure will be. This is referred to as their **daily personal noise exposure** ( $L_{EP,d}$ ). In some cases, a **weekly personal noise exposure** is calculated instead ( $L_{EP,w}$ ). Worker's exposure to **peak sound pressures** from impulse noise (loud bangs) is also measured.

Once a worker's daily personal noise exposure and peak exposure have been estimated, they are compared to the legal standards. There are three of these standards: a lower exposure action value, an upper exposure action value and a limit value.

The **lower exposure action values** are:

- A daily or weekly personal noise exposure of 80 dB(A).
- A peak sound pressure of 135 dB(C) for impulse noise.

The **upper exposure action values** are:

- A daily or weekly personal noise exposure of 85 dB(A).
- A peak sound pressure of 137 dB(C) for impulse noise.



The **exposure limit values (as absolute limits)** are:

- A daily or weekly personal noise exposure of 87 dB(A).
- A peak sound pressure of 140 dB(C) for impulse noise.

If worker exposure lies at or above one of these standards, then the employer is required to undertake certain actions. These actions are set out as follows:

## TOPIC FOCUS

The actions triggered by the three noise at work standards:

- **Lower Exposure Action Value**

At or above this value, the employer must:

- Carry out and record a noise assessment.
- Provide information, instruction and training to employees.
- Make hearing protection available.

(Note that they do NOT have to enforce the use of that hearing protection.)

- **Upper Exposure Action Value**

At or above this value, the employer must:

- Carry out and record a noise assessment.
- Reduce noise exposure to the lowest level reasonably practicable by means other than hearing protection.

If noise levels are **still** above 85 dB(A)/137 dB(C), the employer must:

- Establish mandatory hearing protection zones.
- Provide information, instruction and training to employees.
- Provide hearing protection and enforce its use.
- Provide health surveillance (audiometry). (See later.)

- **Exposure Limit Value**

At or above this value, the employer must immediately prevent exposure and reduce it below the limit value.

So, for example, if a noise assessment shows that a worker's exposure to noise is:

- A daily personal noise exposure of 82 dB(A) as a result of moderately loud background machinery (i.e. above the lower exposure action value but below the upper exposure action value), then the employer must provide information, instruction and training on the risk to hearing and make hearing protection available on request.
- A peak exposure of 139 dB(C) as a result of impulse noise (i.e. above the upper exposure action value but below the limit value), then the employer must reduce exposure using technical and administrative control measures other than PPE to the extent that they can. If this does not reduce exposure below the upper exposure action value (137 dB(C)), then the employer must designate a mandatory hearing protection zone; display signs; provide hearing protection; provide information, instruction and training; and enforce the use of the PPE.

- A daily personal noise exposure of 92 dB(A) as a result of excessively loud machinery use (i.e. above the limit value), then the employer must immediately stop work and reduce exposure below the limit value (perhaps by introducing PPE and then considering how to achieve compliance with the upper exposure action value requirements).

## Basic Noise Control Measures

In simple terms, noise exposure can be controlled in three ways, by:

- Reducing the noise at source.
- Interrupting the pathway from source to receiver.
- Protecting the receiver.

The following sections deal with each of these techniques in more detail.

### Reducing Noise at Source

This can be achieved by:

- **Eliminating the source** – completely remove the noise source; not practical in many instances.
- **Substituting the source** – change the noise source for something else that does the same job but generates less noise (e.g. change a petrol-driven machine for an electric version).
- **Modifying the process** – e.g. by changing from glass to plastic bottles, noise from a packing line can be reduced; or by replacing a compressed-air rivet gun with a screw fixing, manufacturing noise can be reduced.
- **Maintenance** – machinery often produces noise because it is in need of maintenance.
- **Damping** – machine parts (especially metal surfaces) can sometimes resonate in harmony with noise being produced by the machine (like a cymbal that rings when hit). This exaggerates the noise generated. Damping changes the resonance characteristics of the metal part to prevent it ringing in this way. This can be achieved by changing the part, stiffening it or even adding material to one side of it.
- **Silencing** – any machine that produces exhaust gases (e.g. a diesel generator) should be fitted with a silencer on the exhaust to suppress noise.



Noisy machines need regular maintenance

### Interrupting the Pathway

This can be achieved by:

- **Insulation** – in some instances, it is possible to build an **acoustic enclosure** around the noise source. Noise is generated inside the enclosure but cannot penetrate through the walls to the outside work environment. For example, a static diesel generator might be placed in a separate building with sound-insulating walls.
- **Isolation** – noise is often transmitted in the form of mechanical vibration from machinery into supporting structures (e.g. from a compressor into the floor it is mounted on). Isolation involves separating the machine from any supporting structure using vibration-absorbent mats or springs. This breaks the transmission pathway.

- **Absorption** – once noise has escaped from its source, it may travel directly to the receiver through air or may be reflected off hard surfaces (such as walls and ceilings). Absorption involves putting sound-absorbing material in the workplace to absorb these sound waves before they can reach the receiver (e.g. a sound-absorbent material might be used to line a wall, preventing reflection of sound waves in much the same way that carpets and curtains in a house stop sound reverberating round the room).

## Protecting the Receiver

This can be achieved by:

- **Acoustic haven** – if the workplace is inherently very noisy and it is not possible to apply the above controls, then an acoustic haven might be built that workers can retreat into to escape the noisy environment.
- **Hearing protection** – if none of the above is effective or possible, then some form of hearing protection should be used to reduce the amount of noise that penetrates to the worker's ear.



## Hearing Protection

Hearing protection prevents harmful levels of noise from reaching the ear.

The two principal types are:

- **Ear defenders or muffs** – these encase the outer ear in a cup with some sort of foam- or gel-filled cushion to seal against the side of the head.

Advantages of Ear Defenders	Limitations
Easy to supervise and enforce use as they are visible	Uncomfortable when worn for long time
Less chance of ear infections	Must be routinely inspected, cleaned and maintained
Higher level of protection possible through all sound frequencies; bone transmission is reduced	Efficiency may be reduced by long hair, spectacles or earrings
Can be integrated with other PPE (e.g. safety helmets)	May be incompatible with some other items worn (e.g. a full-face respirator)
Re-usable	Need dedicated storage facility

- **Ear plugs** – these fit into the ear canal.

Advantages of Ear Plugs	Limitations
Cheap	Difficult to see when fitted, so supervision and enforcement difficult
Disposable	Risk of infection if dirty or if cross-contaminated when inserted
Often more comfortable to wear	They do not interrupt the bone transmission route at all and so give a lower level of protection to high intensity noise
Do not interfere with any other items worn (e.g. PPE)	

Various factors must be taken into account when selecting hearing protection, such as the noise levels and the advantages and limitations of the various types available. Workers should be involved in the selection process. Often, one of the most significant factors is the ease of enforcement (ear defenders can be seen from a distance whereas ear plugs cannot).

Whichever type of hearing protection is chosen, arrangements should be made for:

- Information, instruction and training – on how to wear the hearing protection; its limitations in use; cleaning, maintenance and replacement arrangements.
- Safe storage – in hygienic locations.
- Cleaning:
  - Ear defenders are often designed to be dismantled for easy cleaning.
  - Plugs are usually disposable.
- Maintenance – including routine inspection and replacement of worn parts (e.g. cushions on ear defenders).
- Replacement – of lost or damaged items.

## Attenuation

Each make and model of hearing protection will have their own **attenuation characteristics** – i.e. ability to filter out noise. This is important because the hearing protection selected by the employer must be good enough to reduce noise levels at the worker's ear to an acceptable level. The level of noise able to penetrate the ear must be calculated to ensure that it is below any relevant exposure limit; to do this, information is required on the:

- Noise characteristics of the workplace (from a noise survey).
- Attenuation characteristics of the hearing protection (the reduction in noise level they give). The attenuation characteristics of the hearing protection come from the manufacturer.

Note that ear defenders can give higher attenuation than ear plugs because some noise can be transmitted through the bone of the skull – this transmission route is partly blocked by defenders but not by plugs. Also note that the attenuation characteristics of hearing protection are measured in laboratory conditions. Ear defenders, in particular, can give lower attenuation in practice because of hair, glasses or earrings which push the ear defender away from the side of the head.



Hair, glasses and earrings can stop ear defenders working effectively

## The Role of Health Surveillance

Health surveillance is appropriate for workers exposed to high noise levels, in the form of **audiometry**.

Audiometry is a medical test that quantifies the sensitivity of a person's hearing across a range of frequencies (low pitch to high pitch).

It normally involves the worker sitting in a soundproof booth with headphones on, listening for faint beeps and indicating when the beeps can be heard.

The results can show whether a person's hearing is being affected by exposure to loud noise and, if so, to what extent.

The **Control of Noise at Work Regulations 2005** indicate that audiometry should be carried out on all workers potentially exposed at, or above, the 85 dB(A)  $L_{EP,d}$  /137 dB(C) action level (i.e. those working in mandatory hearing protection areas).

It might also be conducted on workers with known hearing damage at lower levels (80 dB(A)  $L_{EP,d}$  /135 dB(C)).

Any worker who might potentially be exposed to damaging noise levels should be given an audiometry test when they first start work, to establish a baseline for their hearing and to indicate whether they have pre-existing damage.

Audiometry allows:

- Identification of workers with:
  - Pre-existing hearing damage.
  - New hearing damage (which may be work-related).
- Further protection or removal of such workers from high-noise areas (to protect them from further hearing loss).
- Investigation of noise controls to identify and rectify problems (to protect others in the same work area).



Audiometry should be conducted by trained, competent persons with the potential for referral of cases to a medical practitioner.

### MORE...

Browse the Health and Safety Executive (HSE) website for more information on noise at work, at:

[www.hse.gov.uk/noise](http://www.hse.gov.uk/noise)

### Legal Standards

- ILO C155 – Occupational Safety and Health Convention, 1981 (No. 155).
- ILO R164 – Occupational Safety and Health Recommendation, 1981 (No. 164).
- ILO C148 – Working Environment (Air Pollution, Noise and Vibration) Convention, 1977 (No. 148).
- ILO R156 – Working Environment (Air Pollution, Noise and Vibration) Recommendation, 1977 (No. 156).

### STUDY QUESTIONS

1. What does a daily personal exposure of 85 dB(A) mean?
2. What are the limitations of ear defenders and ear plugs?

(Suggested Answers are at the end.)

# Vibration

## IN THIS SECTION...

- Exposure to excessive vibration into the hand can cause Hand-Arm Vibration Syndrome (HAVS). Health effects can also be seen for whole-body vibration.
- Exposure standards exist for both hand-arm vibration and whole-body vibration.
- Vibration exposure can be controlled by:
  - Reducing the vibration at source – by eliminating the source, substituting the source, changing work techniques and maintenance.
  - Interrupting the pathway from source to receiver – isolation.
  - Limiting the duration of exposure.
- Health surveillance is required where workers are exposed to high levels of hand-arm vibration.

## Introduction to Vibration

Vibration is similar in many respects to noise, both in terms of its physical characteristics and preventive measures. Vibration is the oscillatory (back and forth) motion of an object. There are two types of vibration exposure that give rise to occupational health effects:

- **Hand-arm vibration** – this is mechanical vibration that passes into the hands and arms as a result of the hands having been on the handles or grips of a tool.
- **Whole-body vibration** – this is the mechanical vibration that passes into the body through the feet and legs or backside as a result of standing or sitting on a vibrating surface.

So, for example, a worker using an angle grinder would be exposed to hand-arm vibration, whereas a dumper truck driver would be exposed to whole-body vibration.

## Health Effects of Exposure to Vibration

The health effects associated with vibration exposure depend on the type of exposure and fall into two main categories.

### Hand-Arm Vibration Syndrome

**Hand-Arm Vibration Syndrome (HAVS)** is a condition that specifically affects the hands and arms as a result of a significant hand-arm vibration dose.

Symptoms include:

- **Vibration white finger** – the blood supply to the fingers shuts down (often in response to cold) and the fingers turn white (known as 'blanching'). The blood supply returns after a time and the fingers become red and painful.
- **Nerve damage** – the nerves carrying sensory information from the fingers stop working properly, resulting in 'pins and needles' and a loss of pressure, heat and pain sensitivity.



Typical vibration white finger  
Source: L140 *Hand-arm vibration*,  
HSE, 2005  
([www.hse.gov.uk/pubns/priced/l140.pdf](http://www.hse.gov.uk/pubns/priced/l140.pdf))

- **Muscle weakening** – where grip strength and manual dexterity are reduced.
- **Joint damage** – abnormal bone growth at the finger joints can occur.

HAVS normally results from long-term exposure (5 to 10 years or more) to hand-arm vibration (e.g. from use of a chainsaw). It is an incurable condition. Once damage has been done, it is unlikely to reverse, and any further exposure to vibration will do further damage. The most appropriate treatment for most workers is for them to give up the use of vibrating hand-tools.

The other health effect associated with hand-arm vibration exposure is **carpal tunnel syndrome** (see Work-Related Upper Limb Disorders in Element 6).

## Whole-Body Vibration Effects

The most significant health effect is back pain as a result of damage to the soft tissues of the spine (such as the intervertebral discs which are outlined in Element 6) though other effects have been reported (such as vertigo). Health effects can result from a significant vibration dose to the body, normally through the backside from sitting (e.g. a dumper truck driver) or the feet and legs from standing (e.g. aircraft cabin crew). This is a relatively poorly understood area of concern.

## The Assessment of Vibration Exposure

There are many parallels between vibration and noise as an occupational health risk. Damage to the body in the form of HAVS and back pain is dependent on the dose of vibration that a person receives.

This dose of vibration is determined by the **vibration magnitude** (the level of vibration) that the person is exposed to, in combination with the duration of time that they are exposed to it for.

In order to work out what a worker's exposure to vibration is in the workplace, and whether or not the dose of vibration that they have been exposed to is excessive, employers must undertake some form of technical **vibration assessment**. In most countries, this vibration assessment requirement is written into legal standards. Though the technical details vary, it is easiest to demonstrate the general principle by considering one regulatory regime: the one used in the UK and the EU.

Vibration assessments are required, by the **Control of Vibration at Work Regulations 2005**, where workers are likely to receive a significant exposure to vibration.

Vibration exposure standards are set on the basis that the amount of damage done is dependent on the amount of energy absorbed by the body.

This is determined by the:

- **Vibration magnitude** (measured in  $m.s^{-2}$ ).
- **Duration of exposure** (in hours and minutes).

These two factors determine the dose of vibration absorbed (the same principle as applied to noise). This dose is called the **eight-hour energy equivalent vibration magnitude**, or **A(8)**. This is the same principle as the daily personal noise exposure,  $L_{EP,d}$ .

When undertaking a vibration assessment, it is necessary to estimate a worker's actual exposure to vibration (which will fluctuate) and then calculate what the equivalent eight-hour exposure will be. An assessment might measure vibration exposure directly using a meter (accelerometer) or it might use manufacturers' data.

The results of a vibration survey need to be interpreted to give an accurate estimate of workers' exposures. These exposures can then be compared to the legal standards and any necessary action identified.

Vibration measurement and assessment is a complex topic that should only be undertaken by a competent person.

## Vibration Exposure Standards

The Regulations recognise the two different types of vibration exposure (hand-arm vibration and whole-body vibration) and two daily personal vibration exposure levels are set which put different legal requirements on the employer. One is called the daily exposure action value, the other is the daily exposure limit value.

- **The daily exposure action value is:**
  - 2.5 m.s<sup>-2</sup> A(8) for hand-arm vibration.
  - 0.5 m.s<sup>-2</sup> A(8) for whole-body vibration.
- **The daily exposure limit value is:**
  - 5.0 m.s<sup>-2</sup> A(8) for hand-arm vibration.
  - 1.15 m.s<sup>-2</sup> A(8) for whole-body vibration.

If workers are exposed to either hand-arm vibration or whole-body vibration at or above either of these levels then the employer must take action.

### TOPIC FOCUS

The actions triggered by the two vibration at work standards:

- **The daily exposure action value** (2.5 m.s<sup>-2</sup> A(8) for hand-arm vibration; 0.5 m.s<sup>-2</sup> A(8) for whole-body vibration).

At or above this level, the employer must:

- Carry out a vibration assessment.
- Reduce vibration exposure to the lowest level reasonably practicable.
- Provide information, instruction and training to employees.
- Carry out health surveillance.

- **The daily exposure limit value** (5.0 m.s<sup>-2</sup> A(8) for hand-arm vibration; 1.15 m.s<sup>-2</sup> A(8) for whole-body vibration).

The employer must:

- Carry out a vibration assessment.
- Immediately reduce exposure below the exposure limit value.

Please note that there is no mention in the legal standard of the use of PPE as a control option.

So, for example, if a vibration assessment shows that a worker's exposure to noise is:

- A hand-arm vibration A(8) of 3.5 m.s<sup>-2</sup> (i.e. above the exposure action value but below the limit value), then the employer must reduce exposure to the extent that they can. They must also provide information, instruction and training to employees and health surveillance.
- A whole-body vibration A(8) of 1.5 m.s<sup>-2</sup> (i.e. above the limit value), then the employer must immediately stop work and then reduce exposure below the limit value.

## Basic Vibration Control Measures

In simple terms, vibration exposure can be controlled in three ways:

- Reduce the vibration at source.
- Interrupt the pathway from source to receiver.
- Limit the duration of exposure.

Note that, unlike noise, there is no PPE option. This is because there is conflicting evidence about the effectiveness of PPE at preventing vibration transmission and many authorities do not recognise PPE as a means of exposure control.

### Reduce Vibration at Source

- **Eliminate the source** – completely remove the vibration source, perhaps by mechanising the use of tools (e.g. using a concrete breaker mounted on an excavator arm rather than hand-operated) or by changing work methods (clamping rather than welding, removing the need to grind away welds).
- **Substitute the source** – change the vibration source for something else that does the same job but generates less vibration. This can be done by changing the type of equipment or tool being used, but can often be achieved by using the same type of tool but simply buying a low-vibration magnitude model.
- **Changing work techniques** – there may be ways of doing the work that do not produce as much vibration (e.g. cutting holes in masonry using a diamond-tipped drill rather than a tungsten hammer drill).
- **Maintenance** – machinery often produces vibration because it is in need of maintenance. Bits in particular should be kept sharp.



This job involves vibration exposure to the hands that must be assessed and controlled

### Interrupt the Pathway

- **Isolation** – vibration is transmitted through solid materials by direct contact (e.g. from the two-stroke motor of a chainsaw, to the chassis supporting that motor, to the handles, to the hands). Isolation involves separating vibrating parts from the user's hands using anti-vibration mountings. This breaks the transmission pathway. This approach can be applied to hand-tools, such as chainsaws, and to vehicles – the suspension of a seat in a vehicle cab is isolating the driver from vehicle vibration.

### Limit the Duration of Exposure

There is a direct relationship between vibration dose and duration of exposure: halve the time, halve the dose. This leads to two possible control options:

- **Limit the duration of exposure** by calculating how long a worker might use a particular tool before they approach a relevant action or limit value.
- **Job rotation**, so that vibration exposure is shared between several workers with no one worker receiving above the relevant action or limit value.

We noted above that PPE may not give protection from vibration exposure because it may not prevent transmission of vibration from hand grip to hand effectively. In spite of that, hand protection is important when using vibrating hand tools because the hands should be kept warm and dry. Cold, wet hands are more prone to injury from vibration and symptoms are more likely to be expressed, so gloves should be worn to keep the hands warm and dry.

As with all workplace precautions, information, instruction and training are essential control measures. Operators should be aware of the hazards and risks associated with hand-arm and whole-body vibration and the controls implemented to reduce those risks. They also need to be aware of the signs and symptoms associated with exposure and how to report problems.

## Role of Health Surveillance

Health surveillance is appropriate for workers exposed to high-vibration levels. In the first instance, this health surveillance might simply consist of looking at a worker's medical history and asking about symptoms of health effects. If problems are detected, then tests might be carried out.

Health surveillance should usually be carried out on all workers potentially exposed at or above the exposure action value. Any worker who might potentially be exposed to damaging vibration levels should be checked when they first start work to establish a baseline and to indicate whether they have pre-existing damage.

As with noise, health surveillance allows:

- Identification of workers with:
  - Pre-existing damage.
  - New damage (which may be work-related).
- Removal/exclusion of such workers from vibration sources (protecting them from further injury).
- Investigation of vibration controls to identify and rectify problems (protecting others in the same work).

Health surveillance should be conducted by trained, competent persons with the potential for referral of cases to a medical practitioner.

### MORE...

More information on vibration at work can be found on the HSE website at:

[www.hse.gov.uk/vibration](http://www.hse.gov.uk/vibration)

### Legal Standards

- ILO C155 – Occupational Safety and Health Convention, 1981 (No. 155).
- ILO R164 – Occupational Safety and Health Recommendation, 1981 (No. 164).
- ILO C148 – Working Environment (Air Pollution, Noise and Vibration) Convention, 1977 (No. 148).
- ILO R156 – Working Environment (Air Pollution, Noise and Vibration) Recommendation, 1977 (No. 156).

### STUDY QUESTION

3. Identify the symptoms of HAVS.  
(Suggested Answer is at the end.)

## Radiation

### IN THIS SECTION...

- Non-ionising radiation can be categorised as: ultraviolet (UV), visible, infrared (IR), microwave and radiowaves.
- UV, visible and IR radiation can cause eye and skin damage; microwaves and radiowaves cause internal heating.
- The control of exposure to non-ionising radiation is by use of clothing and PPE or by maintaining a safe distance from the source and by isolation, Safe Systems of Work (SSWs) and permits.
- Ionising radiation comes in five forms: alpha particles, beta particles, X-rays, gamma-rays and neutrons.
- Exposure to ionising radiation can cause acute radiation sickness and can have chronic health effects, such as increased risk of cancer.
- The control of exposure to ionising radiation is based on the principles time, distance and shielding. Dose limits apply.
- Radon is an alpha particle-emitting form of radioactive gas that can build up to hazardous levels in certain premises. Radon gas levels can be measured and appropriate controls implemented to prevent harmful exposures.

## The Types of Radiation and their Health Effects

### DEFINITIONS

#### NON-IONISING RADIATION

Radiation that does not cause ionisation in the material that absorbs it.

#### IONISING RADIATION

Radiation that causes ionisation in the material that absorbs it.

Radiation is energy that is emitted by a source. Radiation can be categorised into many different types, but all of these types belong to two main classes: **non-ionising** and **ionising**.

## Non-Ionising Radiation

### Types of Non-Ionising Radiation

There are five different types of non-ionising radiation:

- **Ultraviolet (UV)** – high-frequency electromagnetic radiation (light) emitted by white-hot materials, such as the arc produced during arc-welding.
- **Visible light** – electromagnetic radiation between the UV and IR frequencies and visible to the human eye.
- **Infrared (IR)** – lower-frequency electromagnetic radiation (light) emitted by red-hot materials, such as molten metal being poured into castings.
- **Microwaves** – lower-frequency electromagnetic radiation emitted by a microwave generator.
- **Radiowaves** – lower-frequency electromagnetic radiation emitted by an antenna.

(Note that microwaves can be categorised as a subset of radiowaves.)

Lasers are sources of non-ionising radiation and can operate at UV, visible and IR frequencies. Note that those operating at IR and UV frequencies would not be visible to the eye. Laser light is very coherent (the light waves are all aligned with one another) and the beam does not diverge (spread out) over distance. Laser beams are therefore capable of carrying power over a distance.

## Health Effects

The health effects of exposure to non-ionising radiation depend on the type of radiation in question:

- **UV** – this can cause redness and burns to the skin (e.g. sunburn), pain and inflammation to the surface of the eye leading to temporary blindness (often called ‘arc-eye’ or ‘snow-blindness’), increased risk of skin cancer, cancer of the eye and premature aging of the skin.
- **Visible light** – this can cause temporary blindness if intense (disability glare) and permanent eye damage and skin burns if very intense (e.g. a high-powered laser).
- **IR** – this can cause redness and burns to the skin and development of cataracts over time.
- **Microwaves** – these are absorbed and cause internal heating. High doses cause internal organ damage and could be fatal.
- **Radiowaves** – these are absorbed and cause internal heating in the same way as microwaves.

Lasers are classified according to intrinsic safety and power output. A Class 1 laser presents little risk to workers, but a Class 4 laser can cause instant skin and tissue burns and irreversible eye damage.



Fire-fighters will be exposed to high levels of IR radiation

## Typical Occupational Sources of Non-Ionising Radiation

Non-ionising radiation is present in most workplaces and is used for various applications. Typical occupational sources include:

- **UV** – sunlight and arc-welding.
- **IR** – red-hot steel in a rolling mill and glass manufacture.
- **Visible light** – laser levelling device and laser pointer.
- **Microwaves** – industrial microwave oven in a food factory and telecommunications equipment (e.g. mobile phone antenna).
- **Radiowaves** – radio, TV or radar antenna.

## Controlling Exposure to Non-Ionising Radiation

The basic methods for controlling exposure to non-ionising radiation vary depending on the type of radiation involved:

- **UV** – enclose the source, cover exposed skin and protect the eyes. For example, a welder should shield their work area so that passers-by are not exposed to stray UV light, and wear overalls with full-length sleeves to cover the forearms, gauntlets, and a full-face welding visor with dark filter to protect the eyes from UV and intense visible light.
- **IR** – enclose the source, cover exposed skin and protect the eyes. For example, a metal worker should wear overalls, gauntlets and a face visor, goggles or safety spectacles to protect the eyes.

- **Microwaves and radiowaves** – since these types of radiation can be absorbed internally, the control of exposure is achieved by:
  - **Enclosing** the source as far as is possible. For example, a microwave oven is designed as a box to contain the microwave radiation and prevent its escape.
  - Maintaining a **safe distance** from the source of the radiation (generator or antenna). These types of radiation obey the inverse square law, so intensity levels drop off very rapidly as distance from the source is increased.
  - **Isolating** (disconnect power) and locking off the source if workers have to approach inside safe distances. This is achieved by the use of Safe Systems of Work (SSWs) and permit-to-work systems and by interlocking sources so that power has to be isolated in order to open access gates/guards.
- **Lasers** – the degree of protection will depend on class of laser. Little needs to be done for a low-class laser other than to avoid shining it into people's eyes. For high-class lasers, protection includes fully enclosing the light source where possible, eye protection (dark goggles), shielding to prevent escape of the beam and use of non-reflective surfaces.

Where work potentially exposes people to non-ionising radiation, it may be necessary to assess the dose of radiation received. Legislation may set dose limits on exposure to optical non-ionising radiation. For example, in the EU, this is done through two directives that target both optical and radiofrequency radiation. In the UK, these directives were transposed as:

- The **Control of Artificial Optical Radiation at Work Regulations 2010** – which set dose limits on exposure to optical radiation (UV, visible and IR).
- The **Control of Electromagnetic Fields at Work Regulations 2016** – which set dose limits on exposure to microwave and radiofrequency radiation.

Both sets of regulations require that a risk assessment be carried out by a competent person. It may be necessary to appoint a Laser Protection Adviser (LPA) and/or Laser Protection Supervisor (LPS) where high-power laser sources are used at work.



Workwear and PPE covers all exposed skin, with a dark visor to protect the face and eyes from UV, visible and IR radiations generated during oxy-acetylene cutting

## Ionising Radiation

### Types of Ionising Radiation

There are five different types of ionising radiation:

- **Alpha particles** – these are emitted by radioactive material but cannot travel very far through air or thin materials such as paper or skin; they are not very penetrating.
- **Beta particles** – these are emitted by radioactive materials and are more penetrating.
- **X-rays** – a ray of high-energy electromagnetic radiation (light) emitted by an X-ray set (generator). They are very penetrating.
- **Gamma-rays** – a ray of very high-energy electromagnetic energy (light) emitted by some radioactive substances and are very penetrating.
- **Neutrons** – these particles are emitted by certain types of radioactive material and are very penetrating.

## Health Effects

**Acute effects** of exposure to high doses of ionising radiation include:

- Sickness and diarrhoea.
- Hair loss.
- Anaemia, due to red blood cell damage.
- Reduced immune system due to white blood cell damage.

All of the cells of the body are affected by the radiation, but some more so than others. If the dose is large enough, then death will follow in weeks, days or hours.

**Chronic effects** of exposure to ionising radiation include:

- Cancer.
- Genetic mutations.
- Birth defects.

Chronic effects can arise following exposure to high or low doses of radiation. There is no known safe level of exposure below which no chronic effects might occur – instead, there is a clear relationship between dose and the **risk** of these chronic effects (i.e. the larger the dose, the greater the risk).

## Typical Occupational Sources of Ionising Radiation

Ionising radiation is present in a wide variety of workplaces and is used for various applications. Nuclear power stations, scientific laboratories and hospitals are just three typical workplaces where various forms would be encountered.

Typical occupational sources include:

- Alpha particles – smoke detectors and science labs.
- Beta particles – science labs and thickness gauges.
- X-rays – medical radiography and baggage security scanners.
- Gamma-rays – industrial radiography for non-destructive testing of metal and welds.
- Neutrons – nuclear power stations.

## Basic Means of Controlling Exposure to Ionising Radiation

Protection from ionising radiation can be achieved using three simple principles:

- **Time** – minimise the duration of exposure. Like noise and vibration, the dose of radiation received is directly proportional to the duration of exposure: halve the duration, halve the dose.
- **Distance** – the greater the distance from the radiation source to the exposed worker, the lower the dose of radiation received. Alpha and beta particles cannot travel long distances through air, so a relatively small separation distance can have a significant effect.
- **Shielding** – the type required will be determined by the type of radiation. Relatively thin shields can be used to contain alpha and beta particle radiation; X- and gamma-rays require thicker, denser material, such as lead.

Where work potentially exposes people to ionising radiation, it may be necessary to assess the dose of radiation received. International Recommendations established by the International Commission on Radiological Protection (ICRP) set dose limits on exposure to ionising radiation. These are then translated into legal standards (e.g. in the EU, Euratom establishes directives on radiological protection). In the UK, the **Ionising Radiations Regulations 2017** set the following dose limits on exposure to ionising radiation:

- The general public shall not be exposed to more than 1mSv (millisievert) per year.
- Occupational exposure shall not exceed 20mSv per year.

The Regulations require that a risk assessment be carried out. This should be done by a competent person – a Radiation Protection Adviser (RPA) and Radiation Protection Supervisors (RPSs) will need to be appointed.

## TOPIC FOCUS

### Radon Gas

#### The Nature of Radon and the Health Risk

Radon gas is a naturally occurring gas that seeps from the ground. High levels of radon gas are found in certain parts of the world due to the geology in these areas (e.g. in the UK, the Derbyshire Peak District and Dartmoor in Devon).

Radon is a radioactive gas – it emits ionising radiation; it is not a type of radiation, it is a source of radiation. Specifically, radon gas emits alpha particle radiation. The health risk associated with radon gas exposure is an **increased risk of lung cancer**.

Outside and in well-ventilated workplaces, the radon levels are unlikely to be high enough to cause concern. But, in certain areas where radon levels are naturally high and in poorly ventilated, enclosed workplaces (especially basements and other sub-ground level locations), radon levels can become high enough to represent a significant risk to health.

#### Typical Occupational Sources of Radon Gas

Workers who spend significant amounts of time in sub-ground spaces in areas where radon levels are recognised to be high are at risk of radon exposure. Examples would include:

- Workers in a basement office.
- Miners.
- Construction workers involved in tunnelling.

(Continued)

## TOPIC FOCUS

### Control Measures

Controlling the risk presented by radon gas involves the following:

- Undertaking a survey of radon gas levels to determine if the levels are acceptable or require action.
- Where radon levels are shown to be high, it will be necessary to reduce employee exposure. In the UK, the action level for radon gas is 400 Bq/m<sup>3</sup> (becquerels per cubic metre).
- Appointing a RPA to carry out a risk assessment.
- Engineering solutions to high radon levels can often be applied, such as:
  - Installing positive pressure air fans to prevent the radon gas from seeping from the ground up into the workplace.
  - Installing radon sumps and extraction systems to draw radon out of the ground at low level before it can seep into buildings.

## Basic Radiation Protection Strategies

Whether the type of radiation that workers are potentially exposed to is non-ionising or ionising, there are some basic protection strategies that apply in all cases:

- Radiation exposure should be **eliminated** so far as is reasonably practicable.
- Where complete elimination is not possible, then exposure should be **reduced to the lowest level reasonably practicable**.
- Employee exposure must not exceed the relevant radiation **dose limits**.
- Exposure must be **risk-assessed** by a competent person.
- **Training and information** must be given to the potentially affected employees.
- **Health surveillance** may be necessary for exposed employees.



Though the technical detail in the legislation varies, the basic principles outlined above are relevant to both ionising radiation (e.g. in GB the **Ionising Radiations Regulations 2017**) and non-ionising radiation (e.g. in GB the **Control of Artificial Optical Radiation at Work Regulations 2010** and **Control of Electromagnetic Fields at Work Regulations 2016**).

## Role of Monitoring and Health Surveillance

Workers who are exposed to radiation are at risk of health effects arising from exposure, so it may be necessary to carry out monitoring of their radiation dose and health surveillance.

Monitoring can be carried out if there is a need to estimate the worker's exposure to radiation. This is usually done by the use of a dosimeter which consists of a plastic badge or ring that is worn by the worker and is sent to a laboratory for analysis. It can also be done using electronic radiation detectors.

Circumstances requiring health surveillance may include:

- Before working as a classified worker (someone who is exposed to radiation over a specified national limit).
- During periodic health reviews (e.g. annually).
- Special surveillance if a dose limit has been exceeded.
- After ceasing work as a classified worker.

Special consideration may also be required for classified workers who are pregnant or breastfeeding.

### MORE...

The following websites contain more details on the subject of radiation at work:

[www.hse.gov.uk/radiation](http://www.hse.gov.uk/radiation)

[www.gov.uk/topic/health-protection/radiation](http://www.gov.uk/topic/health-protection/radiation)

In the health surveillance, the following types of examination may be carried out:

- Skin checks – to identify lesions which could allow radioactive materials to enter the body.
- Respiratory checks – to ensure that workers who may be required to wear respiratory protection are fit and able to do so.
- Reference to exposure records – checks of the employee's records to determine if dose limits have been exceeded.
- Reference to sickness records – examination of the employee's general health and absence history.

### Legal Standards

- ILO C155 – Occupational Safety and Health Convention, 1981 (No. 155).
- ILO R164 – Occupational Safety and Health Recommendation, 1981 (No. 164).
- ILO C115 – Radiation Protection Convention, 1960 (No. 115).
- ILO R114 – Radiation Protection Recommendation, 1960 (No. 114).

### STUDY QUESTIONS

4. What type of non-ionising radiation is given off by the following pieces of equipment?
  - (a) Radio transmitter.
  - (b) Hot plate in a kitchen.
  - (c) Arc welder in operation.
  - (d) Red-light laser pointer.

5. What are the health risks of visible radiation?

(Suggested Answers are at the end.)

## Mental Ill Health

---

### IN THIS SECTION...

- Stress, anxiety and depression are the single biggest causes of lost time in Great Britain.
- Mental ill health is accompanied by a range of psychological, physical and behavioural symptoms that can have serious consequences for the individual.
- Work-related stress can be defined as an adverse reaction caused by excessive pressure or other demands placed on someone at work. Though not a disease, chronic stress can cause ill health and may act as a trigger for mental ill health, such as anxiety and depression.
- The causes of work-related mental ill health can be grouped under six headings: demands, control, support, relationships, role and change.
- The HSE Management Standards approach to risk assessment establishes six standards to be achieved by the organisation under those same headings:
  - Demands.
  - Control.
  - Support.
  - Relationships.
  - Role.
  - Change.

### The Prevalence of Mental Ill Health Within the Workplace

Finding good quality statistics that show the prevalence of mental ill health on a global scale is not easy because of variations in definitions and standards around the world. Organisations such as the World Health Organization (WHO) and the International Labour Organization (ILO) find it difficult to make definitive estimates. However a good indication can be taken from Britain. The 2018 report from the HSE on work-related stress, anxiety and depression contains the following headline figures:

- The total number of cases of work-related stress, depression or anxiety in 2017/18 was 440,000 cases, a prevalence rate of 1,800 per 100,000 workers.
- The number of new cases was 239,000, an incidence rate of 720 per 100,000 workers. The estimated number and rate have remained broadly flat for more than a decade.
- The total number of working days lost due to this condition in 2017/18 was 15.4 million days. This equated to an average of 25.8 days lost per case.
- In 2017/18, stress accounted for 44% of all work-related ill health cases and 57% of all working days lost due to ill health.

These figures mirror other data collected across the EU.

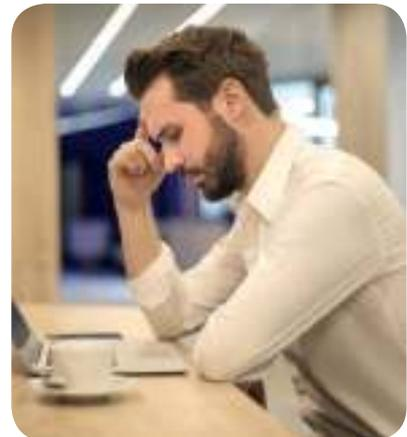

## Common Types of Mental Ill Health

### Anxiety and Depression

#### DEFINITION

##### ANXIETY

*"A feeling of unease, such as worry or fear, that can be mild or severe."*

(Source: NHS)

Anxiety can have both psychological and physical symptoms.

Psychological symptoms can include:

- Feeling worried or uneasy a lot of the time.
- Having difficulty sleeping.
- Inability to concentrate.
- Irritability.
- Being extra alert (hypervigilance).
- Feeling on edge or not being able to relax.

Physical symptoms can include:

- Pounding heartbeat.
- Breathing faster.
- Palpitations (irregular heartbeat).
- Nausea.
- Chest pain.
- Headaches.
- Loss of appetite.

Long-term anxiety can lead to serious ill-health conditions, such as hypertension (chronic high blood pressure). Anxiety is sometimes linked to panic disorder (having panic attacks) and Post-Traumatic Stress Disorder (PTSD), caused by exposure to a traumatic event. It is also sometimes linked to depression.



#### DEFINITION

##### DEPRESSION

*"Feelings of extreme sadness, despair or inadequacy that last for a long time."*

(Source: NHS)

The severity of the symptoms of depression can vary. At its mildest, depression involves being persistently low in spirit (low mood) while, at its most severe, depression makes sufferers feel suicidal and that life is no longer worth living.

Symptoms of depression can include the following:

- Continuous low mood.
- Feelings of hopelessness and helplessness.
- Low self-esteem.
- Guilt.
- Irritability and intolerance.
- Lacking motivation or interest.
- Difficulty with decision making.
- Suicidal thoughts.
- Thoughts of self-harm.



At the more severe end of the scale, depression may lead to a diagnosis of clinical depression that can be categorised as mild, moderate or severe.

## Work-Related Stress

### DEFINITION

#### STRESS

The adverse reaction that people have to excessive pressure or other demands placed on them.

Stress is not a disease, but a natural **reaction** to pressure.

Pressure is an inherent part of work, whether it is a deadline that must not be missed, or a rate of output that must be maintained. Pressure does not necessarily lead to stress because, in many circumstances, people are able to cope with the pressure they are under. In fact, in many situations, pressure results in a positive performance (e.g. athletes tend to produce their very best performances under the pressure of competition, not in training).

However, in some instances, people find themselves **unable to cope with the pressure** that they are under. This leads to a **negative reaction**, rather than a positive one. This reaction is psychological in origin, i.e. the negative reaction is in the mind.

If the pressure is short term, then the person may show some of the signs and symptoms of stress, but it is unlikely that there will be any significant health consequences. It is a common experience to suffer a few sleepless nights worrying about an exam or an interview: the person prepares as much as possible, then afterwards the pressure is relieved and the worry goes away. But if the pressure continues or increases, then the relatively minor symptoms of stress can escalate into **physical and/or mental ill health**.

Work-related stress should not be confused with anxiety or depression. These are common mental health problems that can and do exist entirely independently of work-related stress. It is estimated that a quarter of the population will suffer some form of mental illness at some stage in their lives. The two most common forms of mental illness are anxiety and depression. It is possible to suffer from these mental health problems without being stressed or under any pressure (work-related or not). However, it must be recognised that there is a strong relationship between these mental health problems and work-related stress. The one can trigger or contribute to the other, and vice-versa.

## Causes of Work-Related Mental Ill Health

We can look at the causes of work-related stress under six headings:

- **Demands** – excessive demands of the job in terms of workload (too much or too little), speed of work and deadlines, as well as excessively long working hours and changing shift patterns.  
  
Also consider the nature of the job – some jobs are inherently difficult (e.g. air traffic control) and some expose workers to highly emotional situations (e.g. social work).
- **Control** – lack of control over work, especially where the work is demanding. Control means control over what work is to be done, how it is to be done, the priorities involved and even simple things like control over the working environment (light levels, temperature, background noise, etc.).
- **Support** – lack of support in terms of information, instruction and training to do the work and having no-one to turn to when pressure increases.
- **Relationships** – poor quality workplace relationships and, in particular, bullying and harassment (whether by managers, peers or even subordinates).
- **Role** – lack of clarity about an individual's role, what responsibilities and authority they have, and how they fit into the larger organisational structure.
- **Change** – the threat of change and the change process itself, whether it is a change that affects just one worker (e.g. demotion, re-assignment) or the whole organisation (e.g. redundancies, management take-over). This can create huge anxiety and insecurity.



Excessive workload can be a cause of stress

### The Home–Work Interface

Stress can also be caused by various external factors that put additional pressures on the individual such as excessive commute times/distances, child-care issues, work relocation, etc.

A very significant cause that does not appear in the list above is non-work-related factors. Individuals will go through many difficult times in their lives (e.g. bereavement, separation, family illness) that have nothing to do with their work. Also, some individuals will be predisposed to anxiety and the negative effects of pressure. Though these factors are not work-related, they still have effects in the workplace and so they do need to be considered.

## Staying in Work

Many studies have shown that meaningful work has a positive effect on mental health. Work gives people a purpose, provides mental stimulation and physical activity, and puts people into a social network. Simply put; work is good for you.

It must also be recognised that prolonged absence from work can have a negative impact on a person's mental health. Individuals who are off work for long periods of time can become less active, fail to maintain social contacts, and become socially isolated. They may suffer a loss of self-confidence and have low self-esteem. All of these effects can lead to poor mental health and conditions such as anxiety and depression.

Despite the fact that one in four people will suffer from mental ill health at some stage in their lives, mental health has been stigmatised and those suffering from it have been discriminated against and excluded from work.

So, here we have an example of a vicious circle; people who suffer from stress and mental ill health are excluded from work, and long-term absence from work can cause mental ill health.

Most people who experience stress or mental health problems recover fully or are able to live with and manage them, and continue to work effectively. The employer should adopt policies and procedures that enable those suffering from stress and mental ill health to remain in work.

It is important to remember that equality legislation often makes it unlawful to discriminate against people with mental health problems.

## Control Measures

Since it is not usually possible to remove pressure from the workplace (there will always be deadlines to meet), prevention strategies should focus on providing a basic management framework that takes into account the six factors that cause stress:

- **Demands** – these (in terms of workload, speed of work and deadlines, etc.) should be reasonable and, where possible, set in consultation with workers. Working hours and work patterns should be carefully selected with reference to guidance and worker preference. Flexible working should be allowed where possible. The nature of the job should also be considered and workers selected on the basis of their competence, skills and ability to cope with difficult or emotionally demanding work. Arrangements should be made to allow workers to recover from high-stress situations without fear of punishment.
- **Control** – workers should be given as much control of their work as possible, especially where the work is demanding, i.e. they should be encouraged to take control over:
  - what and how work is to be done;
  - priorities; and
  - their working environment, where possible.
- **Support** – workers should be provided with adequate information, instruction and training; they should have access to additional support when they need it (such as access to a counselling service).
- **Relationships** – clear policies should exist concerning acceptable standards of behaviour in the workplace; bullying and harassment should not be tolerated.



Employers should have policies and procedures in place to help employees get back into work

- **Role** – the organisation should be clear about what an individual’s role actually is, their responsibilities and authority, and how they fit into the larger organisational structure. This should be clearly communicated to the workers and to others across the organisation.
- **Change** – there should be careful planning and preparation of the change process. The reasons for change should be clearly explained and workers consulted where possible. In some situations, change is best done gradually to allow workers to adapt; in others, it is better to implement change quickly to minimise the impact of uncertainty.

Many employers provide a confidential counselling service for employees, which can be provided in-house (by trained employees) or outsourced. This service can be useful to employees in dealing with both work-related and non-work-related matters.

### MORE...

More information on work-related stress can be found here:

[www.hse.gov.uk/stress](http://www.hse.gov.uk/stress)

### Legal Standards

- ILO C155 – Occupational Safety and Health Convention, 1981 (No. 155).
- ILO R164 – Occupational Safety and Health Recommendation, 1981 (No. 164).

### STUDY QUESTION

6. Identify the six work-related causes of stress and, for each, give one example of a preventive measure. (Suggested Answer is at the end.)

## Work-Related Violence

### IN THIS SECTION...

- Work-related violence is any incident where a worker is abused, threatened or assaulted in circumstances relating to their work. Various factors influence the risk of work-related violence and many occupations are at risk.
- Risk of violence can be managed by providing workplace security measures, establishing Safe Systems of Work (SSWs) (especially for lone workers) and providing information, instruction and training.

## Risk Factors and Control Measures

### DEFINITION

#### WORK-RELATED VIOLENCE

*“Any incident in which a person is abused, threatened or assaulted in circumstances relating to their work.”*

(Source: [www.hse.gov.uk/violence](http://www.hse.gov.uk/violence))

Workers can be verbally abused, threatened (verbally and by physical gesture) and even assaulted as they carry out their normal work. There is a growing awareness of this issue and an understanding that abuse, threats and assault are not inevitable occupational risks that should simply be accepted and ignored.

### Risk Factors for Violence

Certain occupations and types of work are associated with an increased risk of violence. The following factors are common to those occupations:

- **Cash handling** – any work that involves the handling of quantities of cash or valuables puts workers at risk of violence associated with robbery.
- **Lone working** – any lone working that takes the worker into urban areas or puts them in contact with members of the public at remote or private locations.
- **Representing authority** – any work where the worker represents authority, such as police, traffic wardens, etc.
- **Wearing a uniform** – uniforms are often seen as a symbol of authority, and therefore those wearing them may be singled out for abuse by those wishing to challenge that authority.
- **Dealing with people under stress** – when people are under stress they are more likely to lose control of their emotions.
- **Dealing with people under the influence** – of drugs and alcohol, or with mental health problems, when normal inhibitions on behaviour have been affected.
- **Censuring or saying no** – workers who have to give warnings, penalties, fines, or who have to refuse a service or say no (e.g. bar staff).



A stressful situation can sometimes spill over into abuse, threat and assault

Occupations at risk of violence involve one or more of these risk factors, such as:

- Hospital accident and emergency staff.
- Police.
- Social workers.
- Bus and taxi drivers.
- Fire-fighters and paramedics.
- Traffic wardens.
- Railway staff.
- Teachers.



## Control Measures for Violence

The first step in managing the risk of work-related violence is to find out the exact nature of the problem. Anecdotal evidence may suggest a problem, but its scale and nature may not be clear.

The extent of the problem can be investigated by:

- Collecting and analysing incident reports.
- Interviewing staff formally or informally.
- Staff surveys.

It will then be possible to identify and implement the correct preventive measures, which will be different depending on the nature of the workplace and of the work. In general, two distinct strategies can be adopted.

Preventing violence **at a central office** can be achieved with:

- Zero-tolerance policy and prosecution of offenders.
- Security staff.
- CCTV cameras.
- Security doors between public areas and staff areas.
- Minimising queues and waiting times.
- Clear announcements about waiting times.
- Training for staff, such as:
  - Providing a good quality service.
  - Diffusing aggression.
- Screens between staff and public.
- Panic alarms.
- Pleasant environment.

Preventing violence to **workers conducting home visits** can be achieved with:

- No lone working or no lone working in certain high-risk areas.
- Keeping records of past incidents.

- Vetting customers.
- Visit-logging with supervisor.
- Pre- and post-visit telephone calls.
- Training for staff, such as:
  - Lone working procedures.
  - Tension diffusion and conflict avoidance.
  - Break-away techniques (self-defence).
- Always having a means of communication (e.g. mobile phone, GPS tracking devices on personnel).
- No visits after dark.
- Parking in secure areas.
- Not carrying cash or valuables.

### MORE...

Follow the links below to read more about work-related violence and personal safety:

[www.hse.gov.uk/violence](http://www.hse.gov.uk/violence)

[www.suzy.lamplugh.org](http://www.suzy.lamplugh.org)

### Legal Standards

- ILO C155 – Occupational Safety and Health Convention, 1981 (No. 155).
- ILO R164 – Occupational Safety and Health Recommendation, 1981 (No. 164).

### STUDY QUESTIONS

7. Identify some occupations at risk of violence at work.
8. What strategies are available to avoid the risk of violence?

(Suggested Answers are at the end.)

## Substance Abuse at Work

### IN THIS SECTION...

- Drug and alcohol abuse can have serious health and safety consequences in the workplace, both for the worker, others involved in any incident and the employer.
- Drugs and alcohol abuse should be controlled by the employer through clear policies, random testing where necessary, support for affected workers and awareness campaigns.

### Types of Substances Abused at Work

There are several types of substances that may be abused at work. Notable examples include:

- **Alcohol** – sometimes, alcoholic drinks are taken at work or during lunchtime drinks in a local bar. Employees returning to work can then be under the influence of alcohol. Often, the effects of alcohol taken the night before can linger into the next day with detrimental effects, especially to vehicle drivers and machinery operators.
- **Legal or illegal drugs** – legal drugs can be over-the-counter, non-prescription drugs (such as common painkillers) or stronger medicinal treatments prescribed by a doctor. Illegal (controlled) drugs, such as cannabis, heroin, cocaine, etc. may be taken by people both in the workplace and away from it. In all cases, use of such drugs can have detrimental effects on a person – not only leading to higher risks if driving vehicles or operating machinery, but also on their personality, responses, decision making, attitude, etc., putting others at risk as well.
- **Solvents** – sometimes, hazardous substances, such as cleaning solvents, are deliberately abused (e.g. ‘glue-sniffing’). These substances can be highly addictive, have serious effects on a person’s performance and will damage their health.



Drugs and alcohol should be controlled by the employer through clear policies

### Risks to Health and Safety from Substance Abuse at Work

Alcohol is an addictive narcotic drug that significantly impairs the senses and reaction times, even at low doses. Social history has meant that it is widely available, used and abused.

‘Drugs’ is a very broad term that can be applied both to non-prescription and prescription drugs (such as painkillers) and controlled drugs (illegal drugs such as cocaine). Some prescription drugs and most controlled (illegal) drugs are addictive.

The effects of alcohol and drug abuse will vary, but some general signs might be observed, such as:

- Late attendance.
- Increased absenteeism.
- Reduction in quality of work.
- Reduction in work rate.
- Dishonesty.
- Theft, potentially to fund a habit.

- Irritability and mood swings.
- Deterioration in working relationships.

These will all be associated with costs to the employer, not to mention increased risk.

Drugs and alcohol cause sensory impairment, skewed perceptions, impairment to motor control and, in many cases, fatigue and drowsiness. There are obvious safety risks associated with drugs and alcohol (e.g. driving a vehicle or operating machinery under the influence increases the risk to the worker and to others, and critical decisions should not be made with impaired judgment). There are also health risks for the workers, usually associated with long-term abuse (e.g. cirrhosis of the liver due to alcohol abuse).

## Control Measures to Reduce Risks from Substance Abuse at Work

The employer might collect information about the state of the problem in the workplace. Company history may show a clear pattern of drug or alcohol abuse.

The employer should establish a clear **drugs and alcohol policy**. This policy might contain:

- Rules restricting access to alcohol in the workplace or during working hours.
- Statutory legal requirements prohibiting workers from being under the influence of drugs and alcohol (e.g. drink drive laws).
- Non-statutory requirements prohibiting workers from being under the influence that have been set by the employer.
- Arrangements for any random drugs and alcohol testing that workers will be subject to. In some cases, there will be a legal requirement on the employer to carry out random drug and alcohol testing.
- Arrangements for workers to have access to rehabilitation and treatment programmes if they admit to having a problem.
- Disciplinary procedures for workers who refuse assistance, refuse to be tested or who fail a test.
- Provision of information, instruction and training to workers, supervisors and managers.

Drug and alcohol awareness campaigns should also be considered.

Any drug and alcohol testing policy must be justified and clearly explained to workers. There are legal and ethical issues associated with testing regimes that must be carefully considered.

### Legal Standards

- ILO C155 – Occupational Safety and Health Convention, 1981 (No. 155).
- ILO R164 – Occupational Safety and Health Recommendation, 1981 (No. 164).

### STUDY QUESTION

9. Identify signs that an employer might notice in an employee who is abusing drugs or alcohol.  
(Suggested Answer is at the end.)



## Summary

---

This element has dealt with some of the health hazards and controls relevant to noise, vibration, radiation, work-related mental ill health, violence and substance abuse.

In particular, this element has:

- Explained the effects of exposure to excessive noise, noise exposure standards and basic principles of noise assessment.
- Outlined the control of exposure to noise by reducing the noise at source (elimination, substituting, modifying the process, maintenance, damping, silencing), interrupting the pathway from source to receiver (acoustic enclosures, isolation, absorption) and protecting the receiver using engineering controls/PPE (acoustic havens and hearing protection).
- Discussed the effects of exposure to excessive hand-arm and whole-body vibration, the exposure standards and the basic principles of vibration assessment.
- Outlined the control of vibration exposure by reducing the vibration at source (elimination, substitution, changing techniques, maintenance), interrupting the pathway from source to receiver (isolation) and limiting the duration of exposure.
- Described the types of non-ionising and ionising radiation, their health effects and control of exposure (including radon).
- Outlined the types and symptoms of work-related mental ill health, the work-related causes and preventive measures.
- Discussed risk factors for work-related violence and control measures.
- Outlined types of substances abused at work, and risks to health and safety of drugs and alcohol abuse, and the control measures available.

# Practical Assessment Guidance

## Introduction to this Guidance

At the end of each Unit IG2 element, you will find a short section like this one that guides you through the practical assessment.

The practical assessment is broken down into different parts. These are presented sequentially so that you can gradually work your way through each element, adding to your understanding of the practical assessment as you go.

You don't have to complete each part of the assessment when you reach it. It is better to wait until you have studied each element and have looked at all parts of the Practical Assessment Guidance beforehand. If you are feeling hasty, you could read all of the Practical Assessment Guidance first so that you can make a start on the practical assessment as you work your way through the elements. Either way, you have the flexibility to start and progress in the way that suits you best.

## Introduction to the Practical Assessment

The practical assessment requires you to carry out a risk assessment in your workplace. There are several parts to this assessment as shown in the diagram below:



Once you have completed each part, you must write this down on the standard form supplied by NEBOSH in its online Assessment Pack. You can download this form from: [www.nebosh.co.uk](http://www.nebosh.co.uk). It is important that you use this standard NEBOSH form for the assessment – the use of non-standard forms might result in your assessment receiving a referral. Make sure that you use the right form for the course that you are enrolled on. Forms can be completed by hand or electronically – NEBOSH has created two different versions of the form for these options. We recommend that you complete the forms electronically, if at all possible, as this looks more professional.

## Part 1 – Description of the Organisation and Methodology Used



### The Part 1 Form

Part 1 of the NEBOSH form is shown below:

**Unit IG2: Risk assessment**



**Part 1: Background**

*Include in here the organisation's name\* and location\* and number of workers. You must then go on to give a description of the main activity/products/services carried out. You must also describe the area to be risk assessed eg. whole site, and anything else that you consider relevant (approximately 150 to 200 words).*

*You must now give a brief outline on how you conducted the risk assessment (approximately 200 words):*

\* If you're worried about confidentiality, you can invent a false name and location for your organisation but all other information provided must be factual.

Learner number:

Learner name:

Page 1 of 6

**Note:** These forms are for reference purposes only. Please visit the NEBOSH website to obtain the official forms to submit your assessment.

### Box 1– Description of the Organisation

The first step is to provide a brief description of the workplace and write this down in the first box of Part 1 of the NEBOSH form. **Make sure that you include all of the information that is requested in italics at the top of this box.**

Ordinarily the workplace that you choose to describe would be the organisation that you work for but it doesn't have to be. If, for example, you are between jobs, or are self-employed and work in a very small, low-risk location such as a home office, you might choose to carry out this assessment at a larger, complex workplace.

You can provide a false name and/or location for your organisation if you like, to protect the identity of the organisation involved and maintain confidentiality. Everything else must be factual.

You need to think about the scope of the risk assessment exercise. You should choose an area that is large and interesting enough to offer a broad range of hazards and risks. But you also want the whole exercise to be manageable in the time that is available to you. For example, you might look at the whole organisation or just a specific department or division. If you work for a large organisation, we recommend that you concentrate on one site. If that site is very large and complex, then focus on one part of that site.

Bear in mind that in a large organisation you do not need to risk assess every single hazard. You need to identify and assess a representative handful of the most significant hazards from the workplace. So being in a larger, more complex organisation is an advantage because you can selectively pick and choose your hazards from the broad range available. In a small, low-risk organisation, it might be difficult to get a representative handful of significant hazards.

So, in the first box, include the organisation's name and location (even if they are fictitious). Include the number of workers and the shift patterns that are worked. Give a good general description of what the organisation does and the site layout so that the examiner can picture the kind of workplace, the products or services involved, and the sorts of activities that are likely to be carried out there.

You do not need to write a long essay. But you must include a good description and you must address all of the key issues identified at the top of the box. Do **not** skip any of the core information even if it seems obvious or unimportant. The key thing is to give the examiner (who will be unfamiliar with your workplace) a quick overview of the location you have chosen for the risk assessment so that they can picture it. NEBOSH recommends that you write 150–200 words but you can go under or over. Don't worry if you end up going onto a second page.

## Box 2 – Methodology Used

The second step requires you to explain how you carried out the risk assessment (your methodology). Write this down in the second box of Part 1 of the NEBOSH form. **Remember to include all of the information that is requested in italics at the top of this box.**

You should include things such as the sources of information that you consulted, who you spoke to, and how the hazards and controls were identified. For example, if you looked at audit reports to identify some of the significant hazards, or you did a site walkabout, then write about these activities here. If you spent a lot of time researching information online, then say so. State which websites you looked at and which documents you used. If you talked to workers or managers, then say so. You can even give people's job titles, if they were key sources of information, but don't include personal names. The only personal name that should appear anywhere on the assessment is your name at the bottom of every page in the space provided.

It is a good idea to write several paragraphs here and to refer to regulations, codes of practice and official guidance so that the examiner can see that you have looked at the right sources of information. Make use of the HSE website and other authoritative sources of up-to-date information. Check your work to make sure that you get your facts right and that the titles and dates of legislation and other standards are correct.

NEBOSH recommends that you write 200 words for this explanation but you might write more or less depending on the nature of your workplace and how you gathered your information. Again, do **not** skip the core information requested even if it seems obvious or unimportant.

Once you have filled in the two boxes of Part 1, that's the first step completed.

Information on Part 2 – Risk Assessment is presented at the end of Element 6.



# Musculoskeletal Health



## Learning Objectives

Once you've studied this element, you should be able to:

- 1 Describe the risk factors that may give rise to work-related upper limb disorders and appropriate control measures.
- 2 Describe the hazards and control measures which should be considered when assessing risks from manual handling activities.
- 3 Describe the hazards and controls associated with load-handling equipment and the requirements for lifting operations.

<b>Work-Related Upper Limb Disorders</b>	<b>6-3</b>
Musculoskeletal Disorders and Work-Related Upper Limb Disorders	6-3
Musculoskeletal Disorder Risk Factors	6-4
Managing the Risk of Musculoskeletal Disorders	6-5
A Typical Example: Display Screen Equipment	6-6
<b>Manual Handling</b>	<b>6-9</b>
Common Types of Manual Handling Injury	6-9
Good Handling Technique	6-10
Controlling Manual Handling Risk	6-10
<b>Load-Handling Equipment</b>	<b>6-15</b>
Hazards and Safe Use of Manually Operated Load-Handling Equipment	6-15
Powered Load-Handling Equipment	6-17
Requirements for Safe Lifting Operations	6-23
Requirements for Statutory Examination of Lifting Equipment	6-24
<b>Summary</b>	<b>6-26</b>
<b>Practical Assessment Guidance</b>	<b>6-27</b>

# Work-Related Upper Limb Disorders

## IN THIS SECTION...

- Musculoskeletal disorders (MSDs), such as back pain and Work-Related Upper Limb Disorders (WRULDs), can result from repetitive tasks, such as Display Screen Equipment (DSE) use, checkout operation and bricklaying.
- Many factors influence ergonomic risk, such as repetition, force, posture, twisting, rest breaks, equipment design and adjustability, and workplace lighting.
- DSE use can cause WRULDs, back pain and eye strain.
- Precautions for safe use of DSE include: ergonomic assessment of the workstation; provision of basic equipment; short, frequent breaks; eye tests; and the provision of information and training.

## Musculoskeletal Disorders and Work-Related Upper Limb Disorders

When workers sit or stand for long periods of time or carry out repetitive activities, or activities that require them to adopt uncomfortable postures, they are subject to stress and strain on their bodies. This can cause injury to the skeletal system and the soft tissues associated with that system, such as muscle sprains and strains, tendon and ligament injuries, joint injuries and nerve damage. Collectively, these chronic soft-tissue injuries are referred to as **musculoskeletal disorders (MSDs)**.

Typical MSDs associated with poor work design are:

- **Back injuries and back pain** – associated with repetitive handling or poor posture and movement while standing or sitting for long periods of time. Injuries such as back muscle strain, ligament strain and disc injury are common and a significant cause of workplace absence.
- **Work-Related Upper Limb Disorders (WRULDs)** – a collection of conditions that affect the arms and hands. Examples include carpal tunnel syndrome (inflammation of a nerve in the wrist that causes tingling sensations, pins and needles, numbness in the fingers and arm pain) and tenosynovitis (inflammation of the tendons in the forearm that makes finger movement difficult and painful).

Early symptoms of WRULDs often include tingling sensations, numbness and discomfort but then progress to more severe pain and immobility.

- **Other chronic soft-tissue injuries** – associated with sitting, standing or kneeling for long periods of time at work (e.g. painful knee joints as a result of having to kneel down to work under floorboards).

## High-Risk Activities/Repetitive Operations

The following repetitive activities all involve significant risk of MSDs:

- Display Screen Equipment (DSE) use.
- Keyboard operation.
- Factory assembly of small components.
- Supermarket checkout operation.
- Bricklaying.



Badly designed workstations lead to ill health

Each of these activities has a range of factors associated with them that increase the risk of MSDs occurring. Next these risk factors will be examined before applying them to a typical workplace activity – the use of DSE.

## Musculoskeletal Disorder Risk Factors

Various factors influence the risk of MSDs from work activities. These relate to the task that the worker is doing, the equipment that they are using and the environment in which they are working. These factors can be applied to any repetitive work activity, whether it is DSE use, checkout operation, factory assembly line work or bricklaying on a construction site.



An uncomfortable posture leads to MSDs, such as lower back pain

### TOPIC FOCUS

Ergonomic factors that influence risk relate to the task, the equipment and the environment.

**Task factors** include:

- **Repetition** – the need for repetitive movements when carrying out the task (e.g. typing for several hours).
- **Force** – the physical force required to perform the task and the strain this puts on the body (particularly strenuous tasks) (e.g. closing stiff catches on a machine).
- **Posture** – any requirement to adopt an awkward posture (e.g. stooping over into a bin to pick out contents).
- **Twisting** – any twisting action required by the task (e.g. twisting the wrist when using a screwdriver).
- **Rest** – the potential for the worker to rest and recover from any fatigue (e.g. a worker on a production line cannot stop the line; they have to keep working even when fatigued).

**Equipment factors** include:

- **Equipment design** – the shape of the equipment and how this affects ease of use (e.g. a large, shaped handle on a scraper makes it easier to hold and use).
- **Equipment adjustability** – the scope there is for the user to adjust the equipment to suit their personal preferences (e.g. the height of the seat for a computer user).

**Environmental factors** include:

- **Lighting** – the availability of natural and artificial light, and the effect on the worker's ability to see the work clearly.
- **Glare** – the light from a screen that can cause headaches or eye strain, and can also cause workers to adopt poor postures in order to avoid the discomfort.
- **Other environmental parameters** – in particular, temperature, humidity and ventilation that will directly affect the worker's ability to perform the task and their comfort.

If one or a combination of the above factors is inherent in the work, then ergonomic risk exists.

## Managing the Risk of Musculoskeletal Disorders

Countless activities involve significant MSD risk. For example, bricklaying on a construction site involves several of the risk factors noted above, such as:

- The work is repetitive.
- Awkward posture and twisting is necessary.
- Rest periods may be infrequent.
- The work area may be extremely cold and windy or hot, humid and airless.

In general terms, the control of MSD risk can be achieved by introducing changes to the:

- task and the way that it is done;
- tools, equipment and machinery being used; and
- workplace environment;

to suit the individuals carrying out the work.

## Matching the Workplace to Individual Needs

### DEFINITION

#### ERGONOMICS

The study of the relationship between the worker, the work that they are doing, the tools and equipment that they are using, and the environment in which they are working.

The risk of MSDs can be reduced by adapting the workplace to suit the individual needs of workers. This is often referred to as applying an '**ergonomic**' approach.

Ergonomics is concerned with the interaction between people and:

- The tools, equipment or machinery that they are using (e.g. the ease of use of control panels).
- The workplace environment (e.g. suitability of lighting).
- Organisational factors (e.g. shift patterns or hours of work).

The aim of ergonomics is to minimise ill-health effects and optimise efficiency by adapting the workplace to suit the individual. This means taking into account both a person's physical attributes (such as height, shape, muscle strength, etc.) and their mental attributes (processing speed, decision-making ability, etc.). For example, ergonomic principles can be applied to a manual-handling operation to reduce the risk of injury.

This approach can be taken by carrying out an ergonomic risk assessment on work activities where there is a high risk of MSDs (i.e. a risk assessment is carried out with special focus and consideration of the ergonomic issues associated with the work).

In some cases, it may be appropriate to put restrictions on the individuals doing the work (i.e. restricting those people who have a known WRULD to light duties to avoid further injury). The first step in achieving controls is to undertake a risk assessment.

The following examples illustrate the ill-health effects that can occur due to ergonomic risks and the possible control measures that may be implemented.

## A Typical Example: Display Screen Equipment

### The Risks

Use of DSE, or computers and keyboards, is a common workplace activity that has several associated ill-health issues, including:

- **WRULDs** – associated with repetitive use of the keyboard and mouse for long periods of time.
- **Back pain** and other MSDs – associated with sitting in a fixed position, perhaps with poor posture, for long periods of time.
- **Eye strain** – temporary eye fatigue associated with prolonged use of the screen.
- **Fatigue and stress** – associated with the type of work being done (e.g. call centre staff may be subjected to verbal abuse during telephone calls).

These health effects can occur when using desktop computers but are becoming increasingly common in association with the use of laptops and other mobile devices when they are used for long-duration work.

### The Control Measures

Control measures appropriate for DSE use are to:

- Carry out an assessment of the user's workstation to ensure that the equipment and environment meet minimum standards and that the workstation can be adjusted to suit the user.
- Provide basic workstation equipment that meets minimum standards in terms of good ergonomic design.
- Plan the user's work routine so that they can take short, frequent breaks from screen and keyboard use.
- Provide users with a free eye test and, if required, spectacles for screen use.
- Provide information and training to users on the potential health risks of DSE use and the preventive measures – in particular, ergonomic use of the workstation.

In many countries and regions, these measures are incorporated into legal standards. For example, in the EU, they are subject to a directive that in Great Britain is incorporated into the **Health and Safety (Display Screen Equipment) Regulations 1992**.

Some of the minimum standards for workstation equipment and good practices for posture and workstation use are illustrated in the following figure.



The portability of laptops allows them to be used in a casual manner that is inappropriate for long-duration use



Good ergonomics at a DSE workstation

The numbers represent the points to assess and illustrate correct positioning:

1. Adjustable height and angle to seat back.
2. Good lumbar support.
3. Adjustable height seat to bring the hands to a comfortable position on the keyboard. Seat also has a stable five-star base.
4. Correct seat-height adjustment and keeping the feet supported prevents excess pressure on underside of thighs and backs of knees.
5. Foot support if user cannot get their feet on the floor.
6. Space for postural change, no obstacles under the desk; this allows the user to fidget and change position as they work.
7. Forearms approximately horizontal when hands are on the keyboard.
8. Minimal extension, flexion or deviation of wrists; wrists should be straight and flat when on the keyboard indicating proper seat height adjustment.
9. Screen height and tilt should be adjustable so as to allow comfortable head position.
10. Space in front of the keyboard to support hands/wrists during pauses in typing; a wrist-rest can provide further support if required.

Additional points:

- The desk should be laid out to minimise the need for twisting or overreaching (e.g. when reaching for a telephone).
- A document holder may be required.
- If frequent telephone use is necessary when using the keyboard, a headset may be required.
- Workplace lighting should be provided to avoid reflections on the screen and glare.

Unfortunately, some of these good ergonomic principles cannot be applied when using a laptop. If laptops are going to be used in the workplace:

- Aim for short-duration rather than long-duration use.
- When used for long durations, apply the same management approach of workstation assessment: frequent breaks, eye test, information and training.
- Provide a docking station and/or separate screen, keyboard and mouse as required to allow the user to convert the laptop to a more adjustable configuration.

### MORE...

Browse the following website for some more information on MSDs:

[www.hse.gov.uk/msd](http://www.hse.gov.uk/msd)

### Legal Standards

- ILO C155 – Occupational Safety and Health Convention, 1981 (No. 155).
- ILO R164 – Occupational Safety and Health Recommendation, 1981 (No. 164).

### STUDY QUESTIONS

1. Outline the aim of ergonomics in a simple phrase.
2. Identify the health risks arising from DSE workstation use.
3. Identify the ergonomic risk factors associated with a repetitive task.
4. Identify the key requirements relating to the following parts of a DSE workstation:
  - (a) Work surface/desk.
  - (b) Keyboard.
  - (c) Chair.
  - (d) Space.

(Suggested Answers are at the end.)

# Manual Handling

## IN THIS SECTION...

- Manual handling is a common cause of musculoskeletal injury, such as:
  - Injury to the back (e.g. a prolapsed disc), tendons, ligaments, muscles.
  - Work-Related Upper Limb Disorder (WRULD).
- Safe lifting technique involves following simple precautions before and during the lift, and when setting down.
- Manual handling can be assessed by looking at four main factors:
  - The task.
  - The load.
  - The environment.
  - Individual capabilities.
- The risk associated with manual handling can be controlled by:
  - Automating or mechanising the handling.
  - Using handling aids.
  - Modifying the task, load or environment.
  - Ensuring individual capabilities are matched to the activity.

## Common Types of Manual Handling Injury

### DEFINITION

#### MANUAL HANDLING

The lifting, carrying, pushing and pulling of a load by bodily force.

Manual handling can involve very repetitive movements of relatively small loads (e.g. handling small components on a production line); in other instances, it can involve one-off movements of very large and heavy items (e.g. handling structural steels into position in an inaccessible location).

All these manual handling activities generate the possibility of injuries, most of which are musculoskeletal injuries.

Common types of manual handling injury include:

- **Back injury** – the spine is made up of individual bones (vertebrae) separated by tough pads (intervertebral discs). Wear and tear can occur to these discs so that they become distorted – this is called a **prolapsed disc**. This causes extreme pain and discomfort and is often accompanied by nerve pain because the distorted disc traps nerves where they enter the spinal cord. This type of injury is perhaps the most serious of all manual handling injuries since recovery is often slow, incomplete and, in some instances, the casualty will have to undergo surgery to repair the defect or may end up permanently disabled.
- **Tendon and ligament injuries** – tendons and ligaments are the connective tissues that join muscle to bone, and bone to bone respectively. When tendons and ligaments are overloaded, they tear, causing extremely painful injuries which can take a long time to heal. In some instances, recovery is incomplete and an operation may be required.

- **Muscle injuries** – overloaded muscle tissue can tear. This is painful and likely to lead to short-term impairment.
- **Hernias** – when the sheet muscle that surrounds the gut is overloaded, it can distort and tear. This usually happens in the lower abdomen and can be a painful injury that will not repair naturally. In many instances, an operation is required.
- **WRULDs** – chronic soft-tissue injuries can occur to the arms, wrists and hands as a result of repetitive movements. This is a generic term for many different medical conditions, such as carpal tunnel syndrome and tennis elbow. WRULDs usually involve inflammation and discomfort through overuse of muscles, tendons or ligaments and, frequently, there is irritation to the nerves that causes additional pain. WRULDs usually start as minor discomfort that gradually worsens to severe pain and immobility. They can result in corrective surgery, and even disability if left untreated.
- **Cuts, burns, dislocation and broken bones** – physical injury may result if the load is hot, sharp or dropped on the feet.



Worker with back injury

## Good Handling Technique

Workers should be trained in efficient movement principles that incorporate basic safe lifting techniques. The following technique minimises the risk of MSDs:

- **Before Lifting**
  - Check the weight, centre of gravity and stability of the load.
  - Plan the route of the carry.
  - Establish a firm grip.
- **The Lift**
  - Bend the knees and use the leg muscles to lift.
  - Keep the back relatively upright but try to maintain its natural S-shaped curve.
  - Keep the load close to the body.
  - Avoid twisting, overreaching and jerking.
- **Setting Down**
  - Use the same principles as when lifting.
  - Maintain good balance.
  - Set the load down and then adjust its position using body weight.



## Controlling Manual Handling Risk

Manual handling activities have to be assessed in order to control the risks of injury to the workers undertaking them. This risk assessment is different from the general risk assessment introduced earlier in this course because it focuses exclusively on the hazard of manual handling and ignores all other hazards.

Manual handling risk assessment focuses on four main factors:

- The task.
- The individual.
- The load.
- The environment.

### HINTS AND TIPS

An easy way to remember the factors in a manual handling risk assessment is by using the acronym 'TILE' for **T**ask, **I**ndividual, **L**oad, **E**nvironment.

In many countries and regions, this risk assessment is subject to legal standards and guidance. For example, in the EU, it is subject to a directive which has been transposed into British law as the **Manual Handling Operations Regulations 1992**.

## The Task

The focus here is on the movements required of the worker as they handle the load.

The **task** can be assessed by asking questions such as:

- At what height is the load being picked up, carried or put down?
- Is the task very repetitive?
- Is a long carrying distance involved?
- Does the task involve stooping (where the worker has to keep their legs straight and bend their back) to move the load?
- Does the task involve twisting (turning the shoulders while the feet stay still)?
- Can rest breaks be taken as the worker requires them?
- Does the task involve lifting the load through a vertical distance?
- Does the task involve reaching above shoulder height?
- Does the task involve the worker holding the load away from their trunk (torso)?

Each of these risk factors increases the risk associated with the task. For example, picking up a load at waist height, carrying it a short distance and putting it down at waist height is a simple task that does not complicate the risk associated with the handling. But picking up the same load from floor height (risk factor 1) from the bottom of a box that requires the worker to stoop down into the box (risk factor 2) then carrying the load at arms' length (risk factor 3) for a distance of 15 metres (risk factor 4) and putting it down above head height (risk factor 5) increases the risk associated with the task very significantly.



Holding a load away from the torso when lifting increases risk of injury

## Individual Capabilities

The focus here is on the worker carrying out the handling activity.

**Individual capabilities** can be assessed by asking questions, such as:

- Does the activity require unusual ability? Some handling activities require unusual strength, stamina, size or technique.
- Does the activity present significant risk to vulnerable individuals, such as pregnant women or people with pre-existing back injuries?

## The Load

Here, the focus is on the load that is being handled.

Though the load is usually an inanimate object, in some workplaces it may be an animal or a person (e.g. in a hospital, patients have to be moved from bed to gurney (a wheeled stretcher/trolley), from a wheelchair to a bath, etc.).

The **load** can be assessed by asking questions, such as:

- How heavy is the load?
- How large and bulky is the load?
- How stable is the load?
- Where is the centre of gravity of the load?
- Is the load difficult to grip?
- Is the load hot, sharp or otherwise hazardous?

For example, the risk associated with handling a concrete block of 12kg is lower than that associated with handling a bundle of flexible plastic pipes, each three metres long, that weighs the same.



How stable is this load?

## The Environment

The focus here is the environment in which the handling takes place.

The **environment** can be assessed by asking questions, such as:

- Are there restrictions on the space available?
- Is the floor surface slippery or uneven?
- Are there changes in floor level (steps, stairs, etc.)?
- What are the light levels like?
- What is the temperature and humidity?

For example, handling activities carried out outdoors on a poorly lit construction site in freezing conditions when there is ice on the ground will be a higher risk than similar activities carried out indoors in a warm, well-lit area.

## Avoiding or Minimising the Manual Handling Risks

Employers should avoid manual handling where there is a risk of injury wherever possible. If this can't be achieved, the risks must be assessed and control measures introduced to reduce the risks to an acceptable level.

Control of manual handling risk can be achieved by using a simple hierarchy:

- Eliminate the manual handling.
- Assess the manual handling that cannot be eliminated.
- Use handling aids.
- Modify the task, load or environment.
- Ensure individual capabilities are matched to the activity.

**Eliminate the manual handling** – automate or mechanise the handling activity. Conveyor belt systems, forklift trucks, electric pallet trucks, cranes, hoists and other types of mechanical moving or lifting equipment provide a way of moving loads without the need for workers to use bodily force.

**Assess the manual handling that cannot be eliminated** – look at the four factors of: task, load, environment and individual capabilities.

**Use handling aids** – consider the use of a piece of equipment that does not completely eliminate the manual handling but does make it much easier. For example, a sack truck does not eliminate the need to push the load, but it does eliminate the need to carry it.

There are many handling aids available such as trolleys, barrel lifts, gin wheels, trucks, hoists and lifts that require some manual effort to lift or support the load, but give the worker mechanical advantage.

**Modify the task, load or environment** – answer the appropriate questions listed earlier. There are usually some simple solutions that present themselves.

Modifications may be possible to reduce the significant risk factors, such as:

- **The Task:**
  - Control repetitive handling by introducing frequent rest breaks or job rotation to minimise the length of time that an individual worker has to perform the task.
  - Eliminate stooping and twisting by changing the layout of the workstation.
  - Use a table or lift to bring the load to waist height to eliminate picking up from floor level.
- **The Load**
  - Break down a heavy load into smaller parts.
  - Use several workers to handle a large, bulky load rather than just one.
  - Stabilise an unstable load by securing it or putting it into a container.
  - Mark up a load with an off-centre centre of gravity so that workers can see where the centre of gravity is.
  - Attach handles to a load that is difficult to grasp.



Electric hoist moving load



Some manual handling aids

- **The Environment**

- Rearrange the workspace to allow more space for the handling activity.
- Level an uneven floor.
- Supply additional lighting in a poorly lit location.

**Ensure individual capabilities are matched to the activity** – check if the activity requiring an unusual ability can be carried out by the workers. For example, if unusual strength and size are required, then the worker must have those characteristics; if a particular technique is required, the worker must be trained so that they develop that technique.

If the activity presents significant risk to vulnerable individuals, such as pregnant women or people with pre-existing back injuries, those people will have to be prohibited from carrying it out.

### MORE...

Browse the following website for some more information on manual handling:

[www.hse.gov.uk/msd/manualhandling.htm](http://www.hse.gov.uk/msd/manualhandling.htm)

### Legal Standards

- ILO C155 – Occupational Safety and Health Convention, 1981 (No. 155).
- ILO R164 – Occupational Safety and Health Recommendation, 1981 (No. 164).
- ILO C127 – Maximum Weight Convention, 1967 (No. 127).
- ILO R128 – Maximum Weight Recommendation, 1967 (No. 128) (to be revised).

### STUDY QUESTIONS

5. Outline the main injuries associated with manual handling.
6. Outline the meaning of the term WRULD and explain how WRULDs might occur.
7. Identify the risk factors associated with a load during a manual handling operation.
8. Identify the main risk factors presented by the working environment in relation to manual handling.
9. Identify the best way of minimising the risks of manual handling.
10. Identify the vulnerable types of individuals who might be more prone to manual handling injury.

(Suggested Answers are at the end.)

## Load-Handling Equipment

### IN THIS SECTION...

- There are many different types of lifting and moving equipment, such as manually operated trucks and hoists, and powered load-handling forklift trucks, lifts, hoists, conveyors and cranes.
- Typical hazards associated with lifting and moving equipment are:
  - Collapse or toppling of the equipment.
  - Falls from height.
  - Falling objects.
  - Being struck by the equipment or the load during movement.
- General precautions for safe use include ensuring that the equipment is:
  - Suitable in terms of strength and stability.
  - Correctly positioned and installed.
  - Visibly marked with the safe working load.
  - Used by competent operators under appropriate competent supervision.
  - Maintained in a safe working condition.
  - Only used for carrying people if it has been designed for that purpose and all additional safety requirements have been implemented.
- Lifting equipment should be routinely inspected and subjected to a statutory thorough examination by a competent engineer.

## Hazards and Safe Use of Manually Operated Load-Handling Equipment

Loads are frequently moved around the workplace using lifting and moving equipment. This equipment may rely on some form of manual effort (such as a trolley, sack truck or pallet truck) or it may be fully powered (such as a forklift truck, hoist, conveyor or crane). Though these devices are useful in minimising the risks associated with manual handling, they do present their own hazards. The hazards and safety precautions of various types of lifting and moving equipment now follow.

### Hazards and Controls for Manually Operated Load-Handling Equipment

There are many different types of manually operated load-handling aids and equipment, such as trolleys, sack trucks, pallet trucks and person-handling hoists (e.g. bath hoist).

**Hazards** associated with this type of equipment include:

- Manual handling risk associated with pushing or pulling the truck.
- Instability of the load causing the load to fall.



Loads are frequently moved around the workplace

- Movement up, down or across slopes causing loss of control.
- Poor parking of the truck causing obstruction in a traffic route.
- Other pedestrians possibly being struck during manoeuvring.
- Trapped feet under the wheels or when lowering the load.
- Entrapment of the person being handled.

**Precautions for safe use** of manually operated equipment include:

- Restricting use to trained workers only.
- Following manufacturer's recommendations.
- Avoiding uneven ground and slopes.
- Using ramps over steps.
- Observing the safe working load limits of the truck.
- Securing the load if necessary.
- Using the brakes (if fitted) whenever the truck is stationary.
- Taking care when moving or lowering the load.
- Ensuring safe parking and storage to avoid obstruction.
- Having routine inspections and maintenance.
- Using safety shoes or boots to avoid crush injuries.

## Lifts and Hoists

A wide variety of items can be included in the phrase 'lifts and hoists' from a simple, manually operated chain hoist to a passenger lift in a multi-storey building. Larger hoists will be looked at later.

### People Hoists and Handling Aids

In some sectors, workers may have to move people, such as hospital patients, and those needing assistance with living requirements in the home. There are a variety of moving and handling aids available, which include:

- **Patient hoists** – these can be manual (where the hoist is lifted by operating a manual crank handle) or powered, and may be mobile or permanently mounted in a ceiling track. Hoists should only be used by trained personnel and the safe working load of the hoist should not be exceeded. The suitability of the equipment for the working environment must also be considered (e.g. pushing a mobile hoist on a carpet or over rugs may be difficult). Lifting equipment of this type should be inspected regularly to ensure it remains in good working order.
- **Small handling aids**, such as slide sheets and transfer boards – these are used to assist the transfer of patients (e.g. from bed to trolley in a hospital). The slide sheet is placed beneath the patient and they are pulled over the slide onto the bed. This allows for the rapid transfer of the patient without lifting them and is used by trained people.
- **Wheelchairs** – a form of handling aid, wheelchairs help in the movement of people. Though they can be powered, most wheelchairs used to transfer patients are simply pushed.



A manual, mobile hoist used to lift a patient

To make sure that workers are competent in using mobility assistance equipment, training in handling techniques should include instruction in the:

- Different types of equipment available, and their appropriate use.
- Safe use of hoists and their slings.
- Re-charging of electric hoists.
- Safe use of smaller aids, such as handling belts and transfer boards.
- Identification of possible faults and safety checks that should be made each time before use.
- Procedures to follow when equipment is damaged and unsafe to use, or if it fails during use.

## Powered Load-Handling Equipment

### Forklift Trucks

There are many different types of forklift truck, but they share a range of common hazards and safety precautions.

The hazards associated with forklift trucks are:

- **Overturn of the truck** – the narrow and short wheelbase of the truck makes it unstable, so it can fall over sideways or tip forwards or backwards very easily. (Some of the poor practices that might cause a forklift truck to overturn are covered in Element 8.)
- **Fall of the load** – the load may fall from the forks of the truck onto the driver or others standing nearby during a lifting operation.
- **Striking of pedestrians** – like all vehicles, a forklift will cause serious injury if it hits a pedestrian.
- **Fall or entrapment of a person riding on the forks** – workers often use the forks of a forklift as a working platform. This practice may result in a fall from height or the worker becoming trapped between the mast of the forklift and fixed structures.
- **Fall from loading dock** – another common accident is where the forklift truck either falls through or off the loading dock that it was driving over to access the back of a lorry.



Counterbalance forklift truck

The engine type and fuel of the forklift truck are also a source of concern:

- **Battery-powered trucks** are commonly used in indoor workplaces. Batteries present several hazards in their own right:
  - Charging lead-acid batteries emit hydrogen gas which is explosive.
  - Lead-acid batteries contain dilute sulphuric acid which is corrosive.
  - Batteries are extremely heavy and present a manual handling risk if they have to be changed for charging purposes.
  - The electricity can cause arcing, shock, burns or fire.
  - Battery contents are an environmental hazard requiring appropriate disposal.
- **Diesel-powered trucks** are commonly used outdoors. Hazards include:
  - Dermatitis, caused by contact of diesel with the skin.
  - Diesel spills, which are a significant slip hazard.

- Large spills, which might pollute the environment.
- Exhaust fumes, which are toxic.
- Those hazards associated with the bulk storage of diesel.

### DEFINITION

#### LIQUEFIED PETROLEUM GAS (LPG)

Propane or butane gas, or mixtures of the two. Can be transported and stored in bulk tanks or in small portable cylinders (e.g. camping gas).

- **Liquefied Petroleum Gas (LPG)-powered trucks** have the following hazards:
  - LPG is an explosive gas.
  - Exhaust fumes are toxic.
  - LPG cylinders are heavy and present a manual handling risk during changing.
  - Those hazards associated with the storage of replacement cylinders or bulk storage of LPG.

### TOPIC FOCUS

The precautions for safe use of forklift trucks include:

- Restricting use to trained operators only.
- Routinely visually inspecting the truck before use.
- Routinely maintaining the truck in accordance with the manufacturer's recommendations.
- Never using the forklift to lift people unless a proper working platform is attached.
- Ensuring that the load on the forks is secure and stable.
- Ensuring that the safe working load limits of the truck are not exceeded.
- Observing site speed limits.
- Never travelling with the forks raised.
- Never travelling with obstructed vision.

Forklift trucks powered by different types of fuel require different precautions:

- **Battery-powered trucks:**
  - Batteries must be charged in well-ventilated areas only, away from ignition sources.
  - Sulphuric acid should only be handled when wearing appropriate Personal Protective Equipment (PPE) (gloves, apron and eye/face protection).
  - Battery handling should be mechanised.
  - The electrical risk may require the use of insulated tools and gloves.

- **Diesel-powered trucks:**
  - These should only be used in a well-ventilated area.
  - Spill kits should be available.
  - Gloves should be worn when handling diesel.
- **LPG-powered trucks:**
  - These should only be used in a well-ventilated area.
  - LPG cylinder handling should be mechanised.
  - Spare cylinders must be stored in a secure, safe, well-ventilated location.

### TOPIC FOCUS

Pre-use checks should be carried out on forklift trucks at the beginning of each shift; these checks must cover:

- Tyre pressures.
- Parking brakes and service brakes.
- Steering.
- Fuel, oil and water systems for levels and leaks (in a combustion engine truck).
- Batteries, to ensure they are charged, are leak-free, chargers are off and leads are stored, and the battery retention device is secured.
- Lifting and tilting systems (including hydraulics) are working, are leak-free and hydraulic fluid levels are correct.
- Audible warning.
- Lights.
- Mirrors.

Any defects should be reported to the supervisor for immediate rectification.

## Lifts and Hoists

Earlier small, manually operated 'people hoists' were covered; here the use of larger powered hoists, from passenger lifts to construction site hoists, is discussed.

The main hazards associated with hoists are:

- Falling objects, such as the load falling from the hoist, or the hoist itself falling due to structural failure.
- Being struck by the load during a lifting operation.
- Becoming entangled in moving parts.

Additional hazards exist when the equipment is used to carry people, such as with a passenger lift, including:

- Falls from height from a landing level or from the platform of the lift itself.
- Being struck by landing levels, parts of any enclosure or other projections while riding on the platform of the lift.



A material hoist for moving materials up and down a scaffold during roof work

Precautions for safe use of hoists and lifts include:

- Ensuring that the hoist or lift is suitable for its intended use – in particular, people should only be carried on equipment specifically designed for that purpose.
- Preventing people from getting underneath the hoist or lift platform or the load during a lifting operation by enclosing the base of the lift or hoist with a fence.
- Preventing people from gaining access to an unprotected landing edge – with a passenger lift, having safety interlocks fitted on the doors at each landing.
- Preventing people being carried on the lift platform from being struck by landings or other obstructions as the lift moves by constructing an enclosure around the lift platform.
- Observing the maximum safe working load of the lift or hoist which should be clearly displayed.
- Ensuring that all safety devices; such as brakes, freefall brakes and interlocks; are in full working order.
- Restricting the use of the hoist or lift where necessary to trained, competent people only.
- Providing information, instruction and training as required.
- Ensuring routine maintenance by competent engineers.
- Ensuring routine inspection and thorough examination as required.

## Conveyors

Conveyors have belts, rollers or screws to move articles or material around and are frequently used in manufacturing and distribution.

The main hazards associated with conveyors are:

- **Drawing-in hazards** or 'in-running nip points' – where fingers might be drawn into moving parts.
- **Entanglement** – where loose clothing might become entangled with rotating parts.
- **Falling objects** – from overhead conveyor systems.

The precautions for safe use of conveyors include:

- Warning alarms or sirens to alert people that the belt is about to start moving.
- Guarding of moving parts to prevent drawing in and entanglement as far as is possible.
- Ensuring that emergency stop buttons or pull-cords are fitted and available for use.
- Barriers to exclude people from the area (protects also from falling objects).
- Fitting guards underneath overhead conveyors to catch falling objects.
- Information, instruction and training for operators.
- Controlling loose clothing and long hair (e.g. by the use of overalls and hairnets in the workplace).
- Maintenance by authorised persons to ensure safe running.
- Provision of a defect reporting system.



A belt conveyor used to move aggregate at a quarry

## Cranes

Many different types of cranes are used in workplaces, from small derricks bolted to the floor at the edge of a loading bay, to large tower cranes positioned at the top of skyscrapers during construction. The mobile crane is used as a typical example.

The main hazards associated with a mobile crane are:

- The crane collapsing or toppling over.
- The boom or jib (arm) of the crane striking against other structures during movement.
- The load (or part of it) falling.
- The load striking against objects or people while being manoeuvred.
- Contact with live overhead cables.



Mobile crane

### TOPIC FOCUS

Factors that might make a mobile crane unstable and topple over include:

- Overloading the crane beyond its lifting capacity.
- Siting the crane on uneven or unstable ground.
- Failing to use the outriggers correctly.
- Using the crane in high winds.
- Extending the boom or jib of the crane too far out for the weight being lifted.
- Structural failing of parts (perhaps due to lack of maintenance).



Summary of handling options available

Source: INDG398 (rev1) *Making the best use of lifting and handling aids*, HSE, 2013  
([www.hse.gov.uk/pubns/indg398.pdf](http://www.hse.gov.uk/pubns/indg398.pdf))

## TOPIC FOCUS

General requirements for safe lifting operations:

- The equipment should be strong enough for the lifting task (rated for the load to be lifted) and suitable for the operation (e.g. forklift trucks must only carry people if a suitable attachment has been installed, such as a man-rider cage, and if the truck has been subjected to any necessary inspections in order to allow the lifting of people).
- The equipment should be stable and secure (e.g. mobile cranes with outriggers (stabilising legs) must be located on firm, level ground to avoid the outriggers sinking and the crane tipping).
- Lifting equipment should be visibly marked with the Safe Working Load (SWL), which is the maximum load that the device is permitted to lift.
- Lifting operations should be planned, carried out and supervised by competent persons. For example, though it is possible to hire a crane and a driver, the lift should also be planned and supervised throughout. It is common practice to carry out a 'contract lift' whereby the planning and execution of the entire lifting process is contracted out to the hire company.
- Equipment that is used to lift people may be subject to additional regulatory inspections.

## Requirements for Safe Lifting Operations

The requirements for safe lifting operations include:

- **Planning and preparation of the lift:**
  - Carrying out a lifting risk assessment by a competent person to determine the correct controls, which will form the basis of the lifting plan for the operation.
  - Checking that the crane has been maintained and has an in-date certificate of thorough examination (see later).
  - Restricting use of the crane to trained and competent operators only.
  - Ensuring the crane or lifting device is of the correct type for the job and terrain; that it is strong and stable.
  - Ensuring that the load to be lifted is within the safe lifting capacity of the crane (and that the safe working load is visibly marked). Safe lifting capacity will vary with the length of the boom or jib and the distance away from the crane that the boom or jib is positioned to (the radius), so capacity can vary from one lift to the next.
- **Carrying out the lift:**
  - Carefully siting the crane on even, stable ground in a safe position away from structures or overheads that might be struck during the lifting operation.
  - Using the outriggers correctly.
  - Ensuring that each lift is planned and supervised by a competent person, and that the operator and slingers are competent.

### DEFINITION

#### SLINGER

The competent person responsible for preparing and slinging a load in readiness for a crane lift, and for attaching or detaching load slings from the crane hook.

- Providing a banksman (signaller) to give directions to the crane operator with good means of communication between the driver and other operators.
- Ensuring that safety devices, such as overload indicators, are operational and are used correctly – these devices are frequently disabled or ignored by the crane operator.
- Checking weather conditions and obeying any manufacturer's recommendations about maximum wind speed. For a mobile crane, typical maximum safe wind speeds would be 14 metres per second (31 miles per hour).
- Using PPE, such as hard hats, steel toe-cap boots and high-visibility clothing.
- Using signs to warn of the operations and exclusion of personnel from the area.
- Ensuring that special requirements for lifting equipment are used for lifting people – equipment which may be used to lift people will be subject to more stringent examination requirements than equipment used to move goods.



Crane lift being supervised

It is also important to consider the **lifting accessories** that are used to attach the load to the crane: items such as chains, wire ropes, nylon slings or eye-bolts and shackles. These must be:

- Attached to the correct lifting points.
- Fitted to the load by competent people.
- In good condition.
- Regularly checked by pre-use visual inspection and subjected to thorough examination.

On lifting, a test lift is usually carried out where the load is lifted just off the ground to test the equipment and balancing, before being lifted smoothly into position. Tag lines may also be used in some lifting operations in order to guide the load into position. Loads should never be left suspended or lifted over people.

## Requirements for Statutory Examination of Lifting Equipment

Lifting equipment is placed under a great deal of strain. If it is not maintained in good working order, it can fail catastrophically. This will almost certainly happen under load, when maximum damage will be done.

Fatalities frequently occur as a result of catastrophic lifting equipment failures. There are, therefore, legal requirements about the thorough examination of lifting equipment to ensure strength and stability. For example, in the EU, lifting equipment is subject to the **Use of Work Equipment Directive (2009/104/EC)**. In Great Britain, this is transposed as the **Lifting Operations and Lifting Equipment Regulations 1998 (LOLER)**.

Lifting equipment should be thoroughly examined:

- Before it is used for the first time (unless it has an in-date certificate of thorough examination from the manufacturer or previous owner).
- Before it is used for the first time where the way that it has been installed will make a difference to its strength and stability.
- Periodically.
- After an event that may have affected its strength and stability.

The frequency of 'periodic' thorough examination will typically be every:

- 12 months where it is not used to carry people.
- Six months where it is used to carry people.
- Six months for lifting accessories (lifting chains, slings, etc.).

This thorough examination must be carried out by a competent engineer.

### MORE...

Follow the link below for some more information on lifting equipment:

[www.hse.gov.uk/work-equipment-machinery/loler.htm](http://www.hse.gov.uk/work-equipment-machinery/loler.htm)

### Legal Standards

- ILO C155 – Occupational Safety and Health Convention, 1981 (No. 155).
- ILO R164 – Occupational Safety and Health Recommendation, 1981 (No. 164).

For construction sites:

- ILO C167 – Safety and Health in Construction Convention, 1988 (No. 167).
- ILO R175 – Safety and Health in Construction Recommendation, 1988 (No. 175).

### STUDY QUESTIONS

11. What are the most common risks associated with the following lifting/moving equipment?
  - (a) Forklift trucks.
  - (b) Sack trucks.
  - (c) Lifts and hoists.
  - (d) Cranes.
12. What PPE might be appropriate when working with the following lifting/moving equipment?
  - (a) Pallet trucks.
  - (b) Cranes.
13. What are the typical safety precautions for safe use of a mobile crane?  
(Suggested Answers are at the end.)



## Summary

---

This element has dealt with some of the hazards and controls relevant to repetitive work activities, manual handling and load-handling equipment.

In particular, this element has:

- Defined ergonomics, identified the MSDs associated with poor work design and identified factors that influence ergonomic risk such as repetition, force, posture, twisting, rest breaks, equipment design and adjustability, and workplace lighting.
- Described the application of ergonomic principles to DSE use.
- Outlined the main types of injury associated with manual handling as MSDs such as injury to the back, tendons, ligaments, muscles and WRULDs.
- Noted the basic principles of safe lifting technique before the lift, during the lift and when setting down.
- Described the four main factors that have to be considered during a manual handling risk assessment: the task, individual capabilities, the load and the environment.
- Explained how risk associated with manual handling can be controlled by automating or mechanising the handling; using handling aids; modifying the task, load or environment; and by ensuring individual capabilities are matched to the activity.
- Considered the hazards and safety precautions associated with different types of load-handling equipment, such as manually operated trucks and mechanically operated forklift trucks, lifts, hoists, conveyors and cranes.
- Outlined the typical hazards as:
  - Collapse or toppling of the equipment.
  - Falls from height.
  - Falling objects.
  - Being struck by the equipment or the load during movement.
- Outlined the general precautions as:
  - Suitability in terms of strength and stability.
  - Correctly positioned and installed.
  - Marked with the safe working load.
  - Used by competent operators under competent supervision.
  - Maintained in a safe working condition.
  - Only used for carrying people if the equipment has been designed for that purpose and all additional safety requirements have been implemented.
- Explained how lifting equipment should be routinely inspected and subjected to thorough examination by a competent engineer.

# Practical Assessment Guidance

## Part 2 – Risk Assessment



The second step in the practical assessment is to carry out a risk assessment exercise and record the results on Part 2 of the NEBOSH form.

### The Part 2 Form

Part 2 of the NEBOSH form is shown below:

**Part 2: Risk Assessment**

Organisation name:  
Date of assessment:  
Scope of risk assessment:

Hazard category and hazard	Who might be harmed and how?	What are you already doing?	What further controls/actions are required?	Timescales for further actions to be completed (if any)	Responsible person's job title

Learned number:                      Learned name:                      Page 2 of 6

**Note:** These forms are for reference purposes only. Please visit the NEBOSH website to obtain the official forms to submit your assessment.

This table appears self-explanatory but it needs to be completed by carefully reading and following the NEBOSH guidance. We will start with the first column where you are required to identify the hazard category and hazard.

Please note that Part 2 of the risk assessment form does not give any indication of word count. As this risk assessment is being done for the purposes of an academic assessment (rather than for work), you should write enough information so that the examiner can clearly understand your intention. Remember that the examiner does not know your workplace and will not be visiting it. It is better to explain things properly rather than write too little on the form. A Part 2 risk assessment that is 10 pages long and contains several thousand words is likely to be better than one that is only four pages long and contains only 500 words.

### Column 1: Hazard Category and Hazard

As you know from your Unit IG1 studies, the first step in the risk assessment process is to identify the hazards. And a hazard is something with the potential to cause harm. So the first column of the risk assessment form is where you need to identify the specific hazards that you intend to talk about in the assessment.

You need to identify **at least 10** significant **hazards**. These must come from **at least 5** of the **hazard categories** that are dealt with in the Unit IG2 course. The hazard categories are:

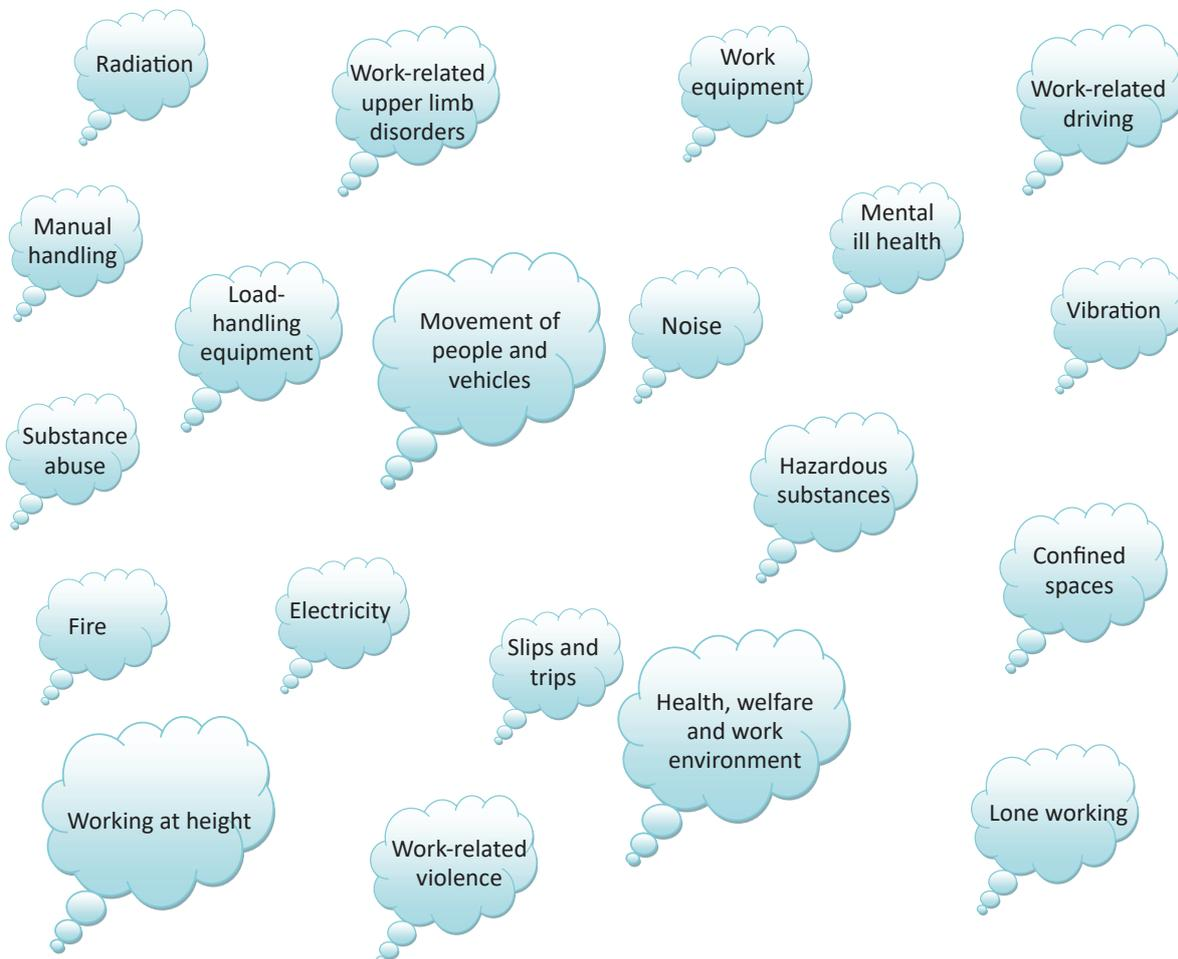

There are 20 categories, so it should be fairly straightforward for you to pick your hazards from 5 or more of them.

As stated in Part 1 of this assessment guidance, you may have a very broad range of hazards in your workplace – possibly a lot more than the 10 or so required in this assessment – so you will need to be selective and pick the most significant hazards from a very broad range. It is fine to have more than 10 hazards, but don't have too many as it is not necessary for the purpose of the assessment and they may detract from your work. Selecting 12 to 14 different hazards from at least 8 different hazard categories would be a sensible approach.

If you struggle to find 10 hazards in your workplace, or you can only find hazards from 2 or 3 hazard categories, then it would suggest that you have not chosen the right workplace to carry out your practical assessment.

Remember that in a risk assessment, you are not just looking for hazards that are poorly controlled or for things that are wrong. This is not an inspection. You are looking for things that have the potential to cause harm. Some of your hazards may be very poorly controlled and some of them may be very well controlled. The key thing is that all of your 10 or more hazards must have significant potential to cause harm in the form of either physical injury or ill health.

As you complete the first column of the risk assessment form, remember to write the information that is requested, at the top of the column, in the right order. You need to put the hazard category first and hazard second. For the hazard category, simply select the name of the topic from the above list of 20. For the hazard itself, identify it by referring to the specific activity or area where it exists.

For example, 'Electricity and use of mains-powered portable electrical equipment in the outdoor yard area' would be an acceptable entry. It identifies the hazard category first (Electricity) and then goes on to identify the specific electrical hazard to be dealt with in the assessment.

But 'Faulty mains-powered drill' would not be an acceptable entry. It does not identify the hazard category, it does not properly identify the specific hazard (no mention is made of where the drill was or if it was in use) and it is far too specific in its focus on one faulty item. Remember this is a risk assessment, so you are looking at the proper management of various types of hazards across your chosen workplace. You are not simply conducting an inspection looking for defects.

The key things to remember here are:

- There must be at least 10 hazards.
- The hazards must come from at least 5 different hazard categories.
- The category is identified in the column first followed by the hazard – which is identified using a little information so the examiner can see the specific nature of the hazard.

Do not identify:

- Fewer than 10 hazards. If you only identify 9, your assessment will be referred.
- Trivial or fanciful hazards. The examiner does not want to know about A4 paper cuts in the office or microwave radiation from mobile phones causing brain cancer. Stick to the significant hazards that are widely recognised by the authorities.
- Hazards from fewer than 5 hazard categories. If you talk about fire safety, fire safety, fire safety, and only fire safety, your assessment will be referred.

Once you have identified your hazards in column 1, you can then move on to column 2. Column 2 asks you to identify who might be harmed and how.

## Column 2: Who Might be Harmed and How?

The second step of the risk assessment process is to identify who might be harmed and how for each of the specific hazards that have been identified in column 1.

When identifying who might be harmed, remember from your Unit IG1 studies that we are interested in broad categories of people such as workers, contractors, visitors and members of the public. We are also interested in groups of people or individuals who might be more vulnerable to the hazard in question, such as new and expectant mothers, young people, lone workers, people with disabilities, etc. Do not name individuals. Identify the groups of people who might be harmed by each hazard. You can identify vulnerable people by reference to their specific characteristic that makes them more vulnerable to the hazard, for example: 'Machine operators in the workshop and the cleaner who is a lone worker.'

You must then write a short description about how these people might be harmed. This should include information about when and how they are exposed to the hazard and the type of harm(s) that might occur. If different people are exposed to the hazard in different circumstances, then say so. If the hazard can cause a range of physical injuries and/or ill-health effects, then say so.

For example:

- 'The machine operator is exposed to the most intense UV radiation from the source, but all other workshop staff can be exposed if they are in the area when the operation is in progress.'
- 'Workers in the room are exposed to this hazard all of the time because it is constantly present.'
- 'Members of the public will occasionally trespass across the marshalling yard. This happens about once a week.'
- 'The solvent is a skin irritant and a skin sensitiser so is capable of causing a range of health effects such as primary contact dermatitis and secondary allergic dermatitis (where the skin suffers a severe allergic reaction to contact with very small amounts of the solvent).'

The key here is to give the examiner an insight into how various people might be harmed by the specific hazard. This is an opportunity for you to demonstrate knowledge that you have learnt from your studies of the Unit IG2 study text and your background research done for this assessment. It is, therefore, a good idea to write more rather than less.

Do not make superficial comments such as 'everyone' for every hazard and do not exaggerate the effects of hazards. It is unlikely that workers will die from manual handling operations. A more foreseeable outcome is that they will receive a range of injuries including muscle strains, tendon and ligament injuries, or prolapsed spinal discs. Remember that the examiner is looking for informed statements.

That's the first two columns of the risk assessment form completed.

Information about the next two columns of the table – the current controls and further controls required – is presented at the end of Element 7.

# Chemical and Biological Agents



## Learning Objectives

Once you've studied this element, you should be able to:

- 1 Describe the forms of, the classification of and the health risks from exposure to hazardous substances.
- 2 Describe what should be considered when undertaking an assessment of the health risks from substances commonly encountered in the workplace.
- 3 Describe the use and limitations of occupational exposure limits including the purpose of long-term and short-term exposure limits.
- 4 Describe control measures that should be used to reduce the risk of ill health from exposure to hazardous substances.
- 5 Describe the hazards, risks and controls associated with specific agents.

<b>Forms of, Classification of and Health Risks from Hazardous Substances</b>	<b>7-3</b>
Introduction to Health Risks from Hazardous Substances	7-3
Forms of Chemical Agents	7-3
Forms of Biological Agents	7-4
Acute and Chronic Health Effects	7-4
Classification of Chemicals Hazardous to Health	7-4
<b>Assessment of Health Risks</b>	<b>7-7</b>
Routes of Entry	7-7
Defence Mechanisms	7-8
Assessment of Health Risks	7-10
Product Information	7-11
Hazardous Substance Monitoring	7-13
<b>Occupational Exposure Limits</b>	<b>7-16</b>
Occupational Exposure Limits	7-16
<b>Control Measures</b>	<b>7-20</b>
The Need to Prevent or Control Exposure	7-20
Principles of Good Practice	7-20
The Practical Control of Exposure	7-21
Further Control of Carcinogens, Mutagens and Asthmagens	7-30
<b>Specific Agents</b>	<b>7-32</b>
Asbestos	7-32
Blood-Borne Viruses	7-34
Carbon Monoxide	7-34
Cement	7-35
Legionella Bacteria	7-36
Leptospira Bacteria	7-37
Silica	7-37
Wood Dust	7-38
<b>Summary</b>	<b>7-40</b>
<b>Practical Assessment Guidance</b>	<b>7-41</b>

# Forms of, Classification of and Health Risks from Hazardous Substances

## IN THIS SECTION...

- Chemicals are encountered in different physical forms such as solids, dusts, fumes, gases, mists, vapours and liquids.
- This significantly affects how these substances might enter the body.
- Biological agents; such as fungi, bacteria and viruses; can be hazardous to health.
- Hazardous substances often have an acute or short-term health effect, they may have a chronic or long-term health effect or they may have both.
- Chemicals are classified according to their health effects as: acute toxicity, skin corrosion/irritation, eye corrosion/irritation, respiratory or skin sensitisation, carcinogenicity/mutagenicity/reproductive toxicity and specific target organ toxicity.

## Introduction to Health Risks from Hazardous Substances

Exposure to chemical and biological health hazards can cause an immediate health risk (e.g. asphyxiation from carbon monoxide (CO) gas) or even physical injury (e.g. corrosive skin burn from sulphuric acid). Less obviously, exposure can also have long-term health effects, which may build gradually over time (e.g. lead poisoning) and, in some instances, will not be apparent until years after the exposure that caused them (e.g. lung cancer caused by asbestos). The forms and classification of chemicals and biological agents that cause these short-term and long-term health effects are detailed in this section.

## Forms of Chemical Agents

The physical form of a chemical makes a big difference to how easily it can enter the body. For example, a bar of stainless steel contains hazardous metals such as chromium and nickel, but they cannot enter the body when the bar is in its solid, massive state. If the bar is welded, then a welding fume is generated and these metals become airborne; now they can be inhaled into the lungs.

The physical forms of chemicals are:

- **Solid** – a solid block of material (e.g. a lead ingot).
- **Dust** – very small, solid particles normally created by grinding, polishing, milling, blasting, etc. and capable of becoming airborne (e.g. flour dust, rock dust).
- **Fumes** – very small, metallic particles that have condensed in the air during work with molten metal (e.g. welding) to create an airborne cloud.
- **Gas** – a basic state of matter; it expands to fill the space available (e.g. carbon dioxide).
- **Mist** – very small liquid droplets suspended in air, normally created by spraying (e.g. paint spraying).
- **Vapour** – the gaseous form of a substance that exists as a solid or liquid at normal temperature and pressure (e.g. vapour given off by acetone solvent).



Dust cloud created by disc grinding wood

- **Liquid** – a basic state of matter; free-flowing fluid (e.g. water at 20°C).
- **Fibres** – thread-like particles that are very small and can become airborne (e.g. asbestos).

## Forms of Biological Agents

Biological agents are microorganisms, such as:

- **Fungi** – moulds, yeast and mushrooms. Most are harmless to humans but some can cause disease, such as fungal infections (e.g. athlete's foot) and farmer's lung (an allergic irritation caused by inhaling mould spores).
- **Bacteria** – single-celled organisms that are found in vast numbers in and on the human body. Some are harmless, some are beneficial (e.g. certain gut bacteria) and some cause disease (e.g. Legionnaires' disease caused by the *Legionella* bacteria).
- **Viruses** – very small, infectious organisms that reproduce by hijacking living cells to manufacture more viruses. Many cause diseases (e.g. hepatitis B, caused by the hepatitis B virus).

## Acute and Chronic Health Effects

Two different types of effect can occur when a person is exposed to a hazardous substance:

- **Acute effects** – the effects are **short-term**. They usually appear immediately or within a relatively short time after exposure, that is, within a few minutes. Acute effects often occur as a result of exposure to high levels of the substance, sometimes over very short periods of time. For example, exposure to high concentrations of chlorine gas causes immediate irritation to the respiratory system.

Acute effects will often disappear once exposure has stopped. However some substances, such as cyanide, have such a pronounced acute effect that exposure is likely to be fatal.

- **Chronic effects** – the effects are **long-term**. Sometimes, the effects will persist for months or years; in some cases they will last a lifetime. Chronic effects usually occur as a result of exposure to lower levels of the substance over long periods of time, are normally gradual and are often progressive and irreversible. For example, respiratory sensitisation to flour dust can occur as a result of repeated exposure to flour dust over several years. Once a worker is sensitised, their reaction to flour dust may last the rest of their life. Some chronic health effects only become apparent years after exposure, for example asbestosis occurs 10–20 years after multiple exposures to asbestos.

Note that many hazardous substances can have both acute **and** chronic effects. For example, exposure to high concentrations of industrial cleaning solvent can have a narcotic effect (acute), and daily exposure to much lower levels can cause liver damage if it continues for many years (chronic). Alcohol is another toxic substance that has both acute and chronic health effects.

Specific examples of chemical and biological agents hazardous to health and outlines of their health effects can be found in the section on specific agents later in this element.

## Classification of Chemicals Hazardous to Health

Chemicals can be broadly classified according to three types of danger:

- **Physico-chemical** – such as highly flammable, explosive or oxidising.
- **Health** – such as toxic or carcinogenic.
- **Environmental** – such as harmful to aquatic life.

In the UK and the EU, the classification of hazardous substances supplied into a workplace is covered by the **European Regulation (EC) No. 1272/2008 on Classification, Labelling and Packaging of Substances and Mixtures (CLP Regulation)**. This Regulation puts a duty on the manufacturer, importer and supplier to appropriately classify any substance or mixture that they supply. They must also ensure that it is appropriately packaged and labelled.

The **CLP Regulation** implements the United Nations (UN) **Globally Harmonized System of Classification and Labelling of Chemicals (GHS)** within the EU. So the classification and labelling of dangerous substances has been harmonised by the introduction of one global standard.

In this element, the **health effects** are the main focal point. These can be further subdivided to give a variety of classifications to indicate how the chemical actually affects health.

### TOPIC FOCUS

Health hazard classifications:

- **Acute toxicity** – small doses cause death or serious ill health when ingested, inhaled or absorbed through the skin (e.g. potassium cyanide).
- **Skin corrosion/irritation** – destroys living skin tissue on contact or causes skin inflammation on contact.
- **Serious eye damage/eye irritation** – destroys eye tissue on contact or causes temporary inflammation of the eye.
- **Respiratory or skin sensitisation** – may cause sensitisation of the respiratory system or the skin through repeated or prolonged contact.
- **Germ cell mutagenicity** – may cause genetic damage that can be passed down to the next generation.
- **Carcinogenicity** – may cause cancer (abnormal and uncontrolled growth of cells in the body).
- **Reproductive toxicity** – may cause sterility or birth defects to an unborn child.
- **Specific target organ toxicity (single and repeated exposure)** – causes damage to body organs as a result of one single, large overexposure or multiple exposures.
- **Aspiration hazard** – may cause damage to the respiratory system if accidentally inhaled into the lungs.

Some chemicals are **sensitising agents**. This means that they are capable of producing an allergic reaction that will gradually worsen on repeated exposures.

There are two groups of sensitising chemicals:

- **Respiratory sensitisers** – these can cause asthma on inhalation into the lungs (e.g. flour dust and isocyanates).
- **Skin sensitisers** – these can cause allergic dermatitis on contact with the skin (e.g. epoxy resin).

## DEFINITIONS

### ASTHMA

A condition where the airways of a person's lungs become irritated in response to a trigger, constricting in size and producing excess mucus, making breathing difficult.

### DERMATITIS

A non-infectious skin condition where the skin becomes dry, flaky, cracked and painful.

There are two main types of dermatitis associated with exposure to hazardous substances:

- **Primary contact dermatitis** – which occurs following immediate, repeated or prolonged contact. Once exposure is stopped, the symptoms subside.
- **Allergic or secondary contact dermatitis** – which occurs following contact with a skin-sensitising agent. This form of dermatitis often appears on parts of the body other than the point of contact with the substance and can flare up in response to very small exposures once the person has become sensitised.

## Legal Standards

- United Nations Globally Harmonized System of Classification and Labelling of Chemicals.
- ILO C170 – Chemicals Convention, 1990 (No. 170).
- ILO R177 – Chemicals Recommendation, 1990 (No. 177).

## STUDY QUESTIONS

1. Identify the physical forms of chemicals that may exist in the workplace.
2. Identify five health hazard classifications of chemicals.
3. Outline the difference between acute and chronic ill-health effects.

(Suggested Answers are at the end.)

## Assessment of Health Risks

### IN THIS SECTION...

- Hazardous substances enter the body by four main routes: inhalation, ingestion, absorption through the skin and injection through the skin. The body's defence mechanisms protect it from the entry of hazardous substances and from their harmful effects.
- Assessing risk from exposure to hazardous substances is a six-step process: identify the hazardous substance present and the people who might potentially be exposed, gather information about the substance, evaluate the health risk, identify any controls needed and implement them, record the assessment and action taken, and review.
- Product labels, guidance notes and safety data sheets are all relevant sources of information in the assessment process.
- It is sometimes necessary to monitor the concentration of a hazardous substance in the air in order to assess the extent of worker exposure to ensure that legal limits are not exceeded.

## Routes of Entry

Some hazardous substances cause harm simply on skin contact. For example, corrosive chemicals (e.g. hydrochloric acid) cause direct chemical burns to the skin, while others irritate and sensitise the skin on contact (e.g. epoxy resin). Many other hazardous substances, however, have to **enter** the body in some way in order to have a harmful effect.

### TOPIC FOCUS

There are four main routes of entry for hazardous substances into the body:

- **Inhalation** – the substance is breathed in through the nose and mouth, down into the lungs. This is a significant route of entry for many hazardous substances in the gas, vapour, mist, fume or dust form. People have to breathe, so if the hazardous substance is present in the air around them, then it will be inhaled.
- **Ingestion** – the substance is taken in through the mouth, swallowed down into the stomach and then moves on through the digestive system. This is a less significant route of entry since people are unlikely to deliberately swallow a hazardous substance. Ingestion usually occurs by cross-contamination (from the hands) or by mistake.
- **Absorption through the skin** – the substance passes through the skin, into the tissues beneath and then into the bloodstream. Only some substances (e.g. organic solvents) are able to permeate the skin in this way, but when they can, this route can be very significant since any skin contact allows absorption.
- **Injection through the skin** – the substance passes through the skin barrier either by physical injection (e.g. a needle-stick injury or animal bite) or through damaged skin (e.g. cuts and grazes). This route is significant for many biological agents (e.g. the hepatitis virus).

These represent the four main routes of entry, though there are others, such as through the lining of the eye (which has a very rich blood supply) and by aspiration (inhaling a liquid into the lungs).

## Inhalable and Respirable Dust

Dust can be inhaled through the nose and mouth, but not all dust will travel down deep into the lungs. Dust is made up of small particles of various diameters. Large dust particles are filtered out by the lungs' defence mechanisms before they can travel down into the lungs; smaller particles are not trapped by these defences and will travel deep into the lungs.

These two types of dust are called:

- **Inhalable dust** – particles of all sizes that can be inhaled into the nose and mouth.
- **Respirable dust** – particles less than 7 microns ( $7/1,000$  mm) in diameter that can travel deep into the lungs on inhaled breath.

## Defence Mechanisms

The body has two main categories of defence mechanism to combat attack by biological agents and chemicals. Very broadly, these are:

- Cellular defence ('internal' defence) – allows cells to fight bacteria and other toxins that have entered mostly from blood, respiratory and ingestion routes.
- Superficial defence ('external' defence) – protects against toxins that enter through the skin and against the collection of contaminants that enter via the nose and throat by trapping them in hairs and mucus.

The following sections will cover some of the basic defence mechanisms.

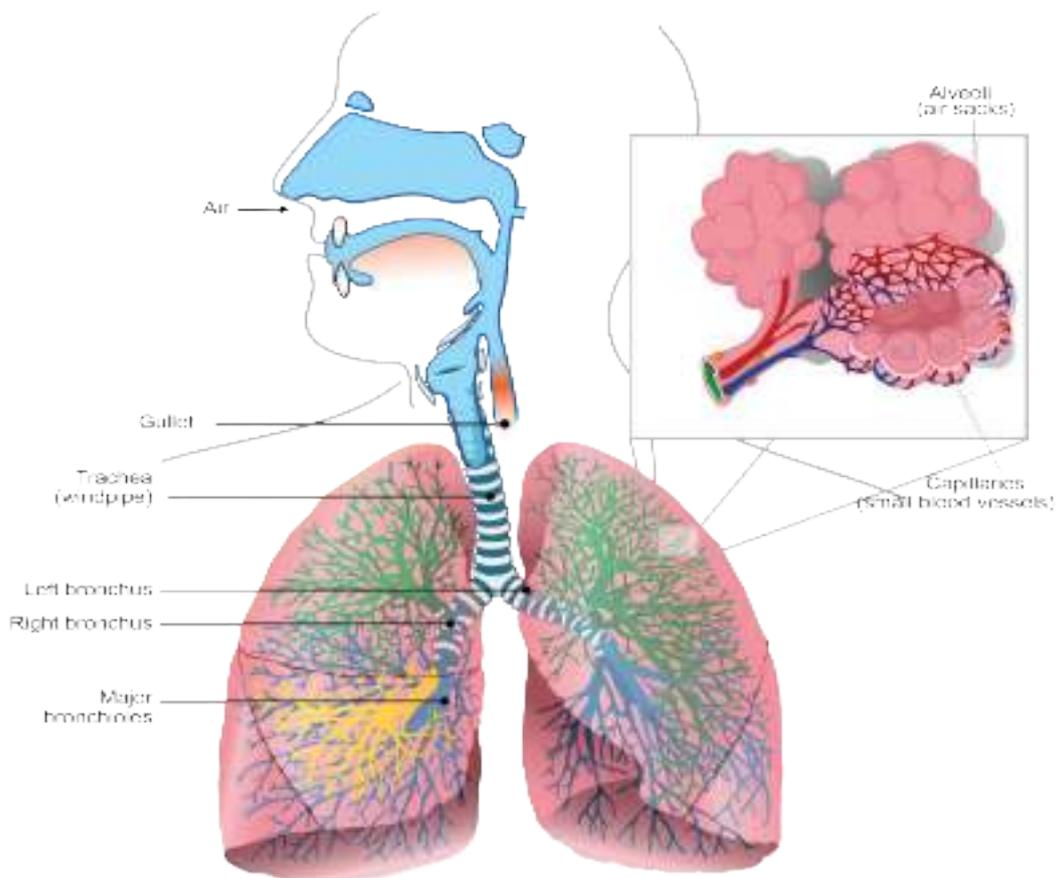

The respiratory system

## Respiratory Defences

The respiratory system is made up of the nose and nasal cavities, the windpipe (trachea) and lungs. The air passes down the bronchi and bronchioles to the alveoli. These are small air sacs and are where oxygen enters the bloodstream.

The respiratory system is protected by the following defences:

- The **sneeze reflex**.
- **Filtration in the nasal cavity** (which has a thick mucus lining that particles stick to) effectively removes large particles; only particles less than 10 microns in diameter pass through. This mechanism will successfully prevent the entry of larger fibres (such as asbestos) and larger particulates in dust (such as silica) but will not prevent smaller asbestos fibres or fine powders, such as cement and finer silica dust.
- **Mucociliary escalator** cleans out particles trapped in the mucus. The bronchioles, bronchi and trachea are lung passages lined with small hairs (cilia). Cilia gradually move mucus up out of the lungs along with any particles trapped in this mucus. This filtration mechanism is effective at removing particles larger than 7 microns in diameter. This will collect medium-sized asbestos fibres, silica and larger particulates in dust, but, again, will not defend against finer fibres and particulates.
- **Macrophages/phagocytes** (scavenging white blood cells) ingest, attack and destroy organic particles. For example, fine dust particles that are not captured by the mucociliary escalator will progress deeper into the lungs where macrophages try to destroy them.
- **Inflammatory response** is triggered by any particles that cannot be removed by macrophages. This response causes the walls of the air sacs (alveoli) to thicken and become fibrous. These changes can be temporary or may result in permanent scarring and reduced lung function. Silicosis is scarring of the lung tissue as a result of the inhalation of silica crystals (e.g. in rock dust) and asbestosis is scarring of the lung tissue caused by inhalation of asbestos.

## Skin Defences

The skin forms a waterproof barrier between the body and the outside world. It is made of two layers, the outer **epidermis** and the inner, thicker **dermis**. Defence mechanisms include:

- A thick layer of dead cells at the surface of the epidermis that are constantly being replenished as they wear off.
- Sebum which is an oily fluid secreted onto the surface of the skin that has antiseptic properties.

When damaged, the skin produces an inflammatory response: the area of damage becomes inflamed, swelling occurs, red and white blood cells collect at the site of the damage, and fibrous cross-connections form and scar tissue may result. Exposure to detergents will remove the protective sebum allowing the agent to contact the skin, causing irritation. More severe reactions can occur through exposure to acids which can burn the skin.

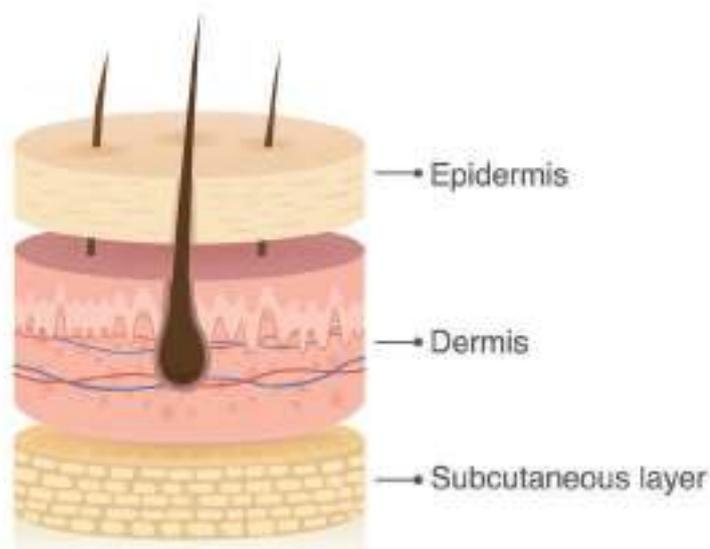

Cross-section of skin

## Assessment of Health Risks

Where workers might potentially be exposed to hazardous substances through the course of their work, it will be necessary to assess that potential to ensure that harm does not occur. In Great Britain, this is a requirement of the **Control of Substances Hazardous to Health Regulations 2002 (COSHH)**. These regulations reflect EU directive requirements.

The steps to carrying out a hazardous substance risk assessment are:

1. Identify the hazardous substances present and the people who might potentially be exposed.
2. Gather information about the substances.
3. Evaluate the health risk.
4. Identify any controls needed and implement them.
5. Record the assessment and action taken.
6. Review.

When identifying the hazardous substances present in the workplace, remember that they can be created by work processes. For example, welding metal creates a metal fume; mixing bleach and acid together can create chlorine gas. These hazardous substances (the metal fume and the chlorine gas) do not come pre-packaged and labelled, but are created by the work process.

Information can be collected about hazardous substances by referring to various sources (see later). This information then has to be used to evaluate the health risks associated with the actual work practices.

### TOPIC FOCUS

Factors to consider when carrying out an assessment of hazardous substance exposure:

- **Hazardous nature** of the substance present – is it toxic, corrosive, carcinogenic, etc.?
- **Potential ill-health effects** – will the substance cause minor ill health or a very serious disease, and will these result from short-term or long-term exposure?
- **Physical forms** that the substance takes in the workplace – is it a solid, liquid, vapour, dust, fume, etc.?
- **Routes of entry** the substance can take in order to cause harm – is it harmful by inhalation, ingestion, skin absorption, etc.?
- **Quantity** of the hazardous substance present in the workplace including the total quantities stored and the quantities in use or created at any one time.
- **Concentration** of the substance if stored, used neat or diluted; and the concentration in the air if airborne.
- **Number of people** potentially exposed and any vulnerable groups or individuals such as pregnant women or the infirm.
- **Frequency** of exposure – will people be exposed once a week, once a day or continuously?
- **Duration** of exposure – will exposure be very brief, last for several hours or last all day?
- **Control measures** that are already in place such as ventilation systems and Personal Protective Equipment (PPE).

All these factors have to be taken into account when undertaking the assessment, then the adequacy of any existing control measures can be decided, and additional controls and precautions selected.

## Product Information

Information about the nature of a hazardous substance can be obtained from many different sources. Three of the most commonly used sources are the:

- Product label.
- Relevant guidance notes that contain information about Occupational Exposure Limits (OELs).
- Safety data sheet for the substance.

## Product Labels

It is becoming more common for labels to be applied which comply with the requirements of more than one country, and the classification and labelling of substances is being harmonised through the implementation of the UN's **GHS**.

A product label will carry the following information:

- The name of the substance/mixture.
- Some idea of the components that make the product hazardous (though this often depends on the overall classification of the product).
- An indication of the danger, which may be by specific warning phrases or symbols, or a combination of both.
- Basic precautions to take (things to avoid or PPE to wear, etc.).
- Name, address and telephone number of the supplier.

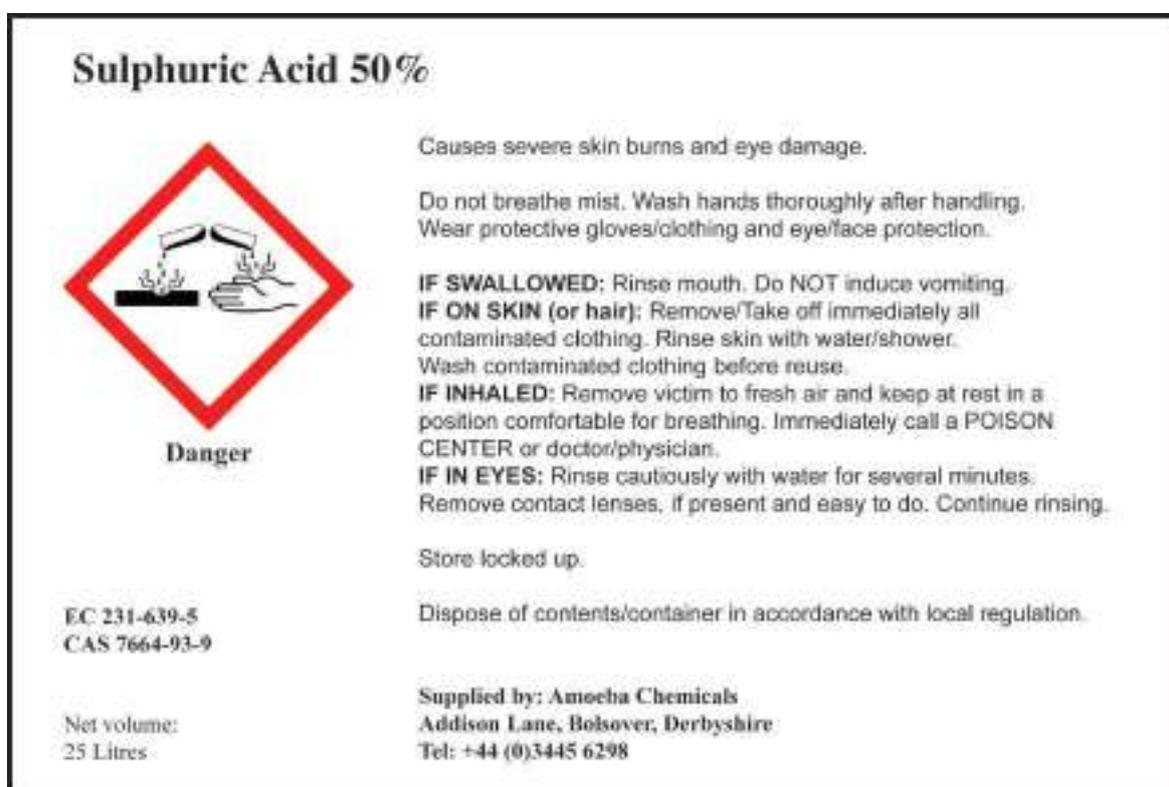

A label showing the key information about the hazardous nature of the product

In the UK and the EU, substances must be classified, labelled and packaged according to the **CLP Regulation (EC Regulation 1272/2008)**.

## Guidance Documents

### Health and Safety Executive Guidance Note EH40

OELs are legal limits on the airborne concentrations of substances that workers can be exposed to. In the UK, these OELs are called **Workplace Exposure Limits (WELs)** and they are published by the Health and Safety Executive (HSE) in **Guidance Note EH40**. This document can, therefore, be a useful source of reference when undertaking a hazardous substance risk assessment. WELs will be explained fully in the next section of this element.

### Other Guidance Notes

Alongside the UK-specific guidance documents, there are OELs published by other authorities such as:

- **EU list of Indicative Limit Values** – the EU has published limit values for 19 chemical agents in the list of Indicative Limit Values. These must be adhered to by the European member states and are recognised in EH40 in the UK.
- **ACGIH list of Threshold Limit Values** – in comparison, the American Conference of Governmental Industrial Hygienists (ACGIH) in the US has developed a series of Threshold Limit Values (TLVs) for certain chemicals that represent guidelines (non-legal standards).

### Safety Data Sheets

The purpose of safety data sheets is to provide end users with sufficient information about a substance so that they can take appropriate steps to ensure safe use, including transport and disposal. The **Registration, Evaluation, Authorisation and Restriction of Chemicals (REACH)** is an EU regulation that requires manufacturers, importers and suppliers of hazardous substances to prepare and provide safety data sheets. The basic design and section headings for this document follow a standard established by this Regulation.

#### TOPIC FOCUS

Safety data sheets contain the following information:

1. **Identification of the substance and of the company** – including name, address and emergency contact phone numbers.
2. **Hazards identification** – summarising the most important features, including adverse health effects and symptoms.
3. **Composition/information on ingredients** – chemical names.
4. **First-aid measures** – separated for the various risks and specific, practical and easily understood.
5. **Fire-fighting measures** – emphasising any special requirements.
6. **Accidental release measures** – covering safety, environmental protection and clean-up.
7. **Handling and storage** – recommendations for best practice, including any special storage conditions or incompatible materials.
8. **Exposure controls/personal protection** – any specific recommendations, such as particular ventilation systems and PPE.
9. **Physical and chemical properties** – physical, stability and solubility properties.
10. **Stability and reactivity** – conditions and materials to avoid.

(Continued)

### TOPIC FOCUS

11. **Toxicological information** – acute and chronic effects, routes of exposure and symptoms.
12. **Ecological information** – environmental effects, which could include effects on aquatic organisms, etc.
13. **Disposal considerations** – advice on specific dangers and legislation.
14. **Transport information** – special precautions.
15. **Regulatory information** – overall classification of the product and any specific legislation that may be applicable.
16. **Other information** – any additional relevant information (e.g. explanation of abbreviations used).

## Limitations of Information

The above sources of information are important but they have the following limitations in assessing health risk:

- They contain general statements of the hazards. They do not allow for the localised conditions in which the substances are to be used which may affect the risk.
- The information can be highly technical and so meaningless to the non-specialist.
- Individual susceptibility to substances varies; a person can be very prone to the health effects of a certain chemical.
- They provide information about the specific substance or mixture in isolation and do not take into account the effects of mixed exposures.
- The information represents current scientific thinking and there may be hazards present that are not currently understood.

## Hazardous Substance Monitoring

### The Role of Hazardous Substance Monitoring

Many hazardous substances are hazardous by inhalation. An obvious question to ask if people are working in an area where they might inhale such a hazardous substance is: 'What is the concentration of this substance in the air?' Sometimes, the only way to answer that question is to undertake some form of **monitoring**. Monitoring makes use of various types of sampling equipment to give an indication of the concentration of a contaminant in the air.

Monitoring might be appropriate in the following circumstances:

- When failure or deterioration of the control measures could result in serious health effects.
- When measurement is required to ensure that an OEL (e.g. WEL) is not exceeded.
- As a check on the effectiveness of control measures.
- If adequate control of exposure is no longer being maintained, following process or production changes, for example.

Monitoring can be carried out using various items of equipment. For example, a personal dosimeter is a measuring device that can be worn by a worker to indicate their personal level of exposure to dust in the workplace. It comprises an air pump, tube and sampling head. A pre-weighed filter is fitted into the sampling head, air is drawn through it by the pump for a chosen period of time, then the filter is removed and re-weighed. The concentration of dust in the atmosphere can be calculated based on these measurements. This will give an average value over the chosen period of time.

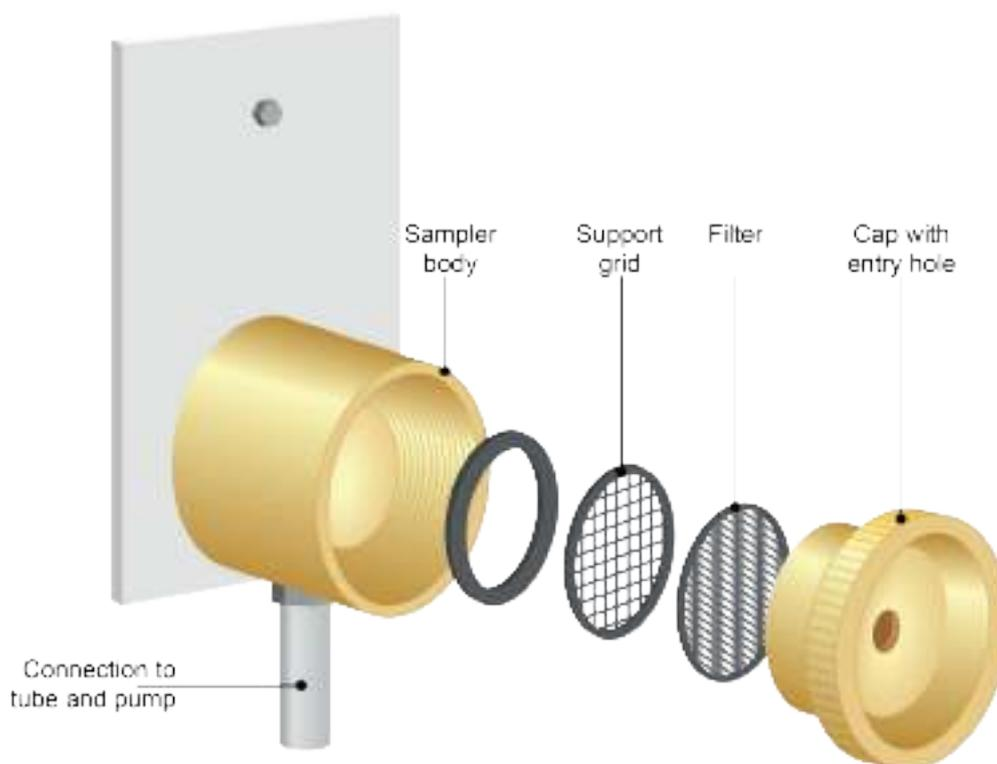

Dust sampler head showing filter in position

Based on original source: MDHS 14/4

*General methods for sampling and gravimetric analysis of respirable, thoracic and inhalable aerosols*, HSE, 2014  
([www.hse.gov.uk/pubns/mdhs/pdfs/mdhs14-4.pdf](http://www.hse.gov.uk/pubns/mdhs/pdfs/mdhs14-4.pdf))

## Limitations of Hazardous Substance Monitoring

There are several limitations that must be considered before monitoring hazardous substances:

- **Accuracy of results** – monitoring equipment is often limited in its accuracy and variations between different times of use will occur.
- **Variations in personal exposure** – even when careful monitoring has been carried out, there may still be variation in a worker's personal exposure from the monitoring results due to personal habits and one-off events.
- **Absence of a standard** – monitoring for monitoring sake is of no use if there is no OEL (e.g. a WEL or TLV) to compare monitoring results to. Not all hazardous substances have an OEL set (see later).
- **Other exposure routes** – monitoring focuses exclusively on airborne contaminants. If the substance can be absorbed through the skin, then another route of entry is available and air monitoring may not give a true indication of the actual exposure that is taking place.

### MORE...

Follow the link below for more details about the **hazardous substances and risk assessment**:

[www.hse.gov.uk/coshh](http://www.hse.gov.uk/coshh)

### Legal Standards

- United Nations Globally Harmonized System of Classification and Labelling of Chemicals.
- ILO C170 – Chemicals Convention, 1990 (No. 170).
- ILO R177 – Chemicals Recommendation, 1990 (No. 177).

### STUDY QUESTIONS

4. Identify the routes of entry of chemical and biological agents into the body.
5. What information is generally provided on the label of a substance which has been classified as dangerous?
6. What is the purpose of safety data sheets?

(Suggested Answers are at the end.)

## Occupational Exposure Limits

### IN THIS SECTION...

- Occupational Exposure Limits (OELs) – Workplace Exposure Limits (WELs) in the UK – are the maximum concentrations of airborne substances, averaged over a reference period, to which workers may be exposed by inhalation.
- Short-Term Exposure Limits (STELs) combat the sudden acute effects of exposure; Long-Term Exposure Limits (LTELs) combat the long-term chronic effects.
- There are limitations to the effectiveness of OELs in ensuring that workers are not exposed to harmful levels of hazardous substances.
- OELs vary by country and region as there are currently no globally recognised standards.

### Occupational Exposure Limits

There are no harmonised global standards for **Occupational Exposure Limits (OELs)**. The terms used to describe them – as well as definitions, methods for calculating exposures and the legal status of the limits – vary between countries. So it is important to select the correct OEL for each country and to use the correct codes of practice in interpretation (see the guidance documents referred to earlier, for example).

The purpose of all OELs is similar – to put a limit in place so that workers will not be exposed to high concentrations of airborne substances (either for short durations of time, or for long periods of the working day) where scientific evidence suggests that this would cause a risk to health.

For the purposes of this course, the specific legal standard that exists within the UK is used as a model for explaining hazardous substance OELs and how they work. In the UK, the OELs for chemicals are known as **Workplace Exposure Limits (WELs)**, and these are defined and have legal status under **COSHH**.



Worker being exposed to airborne contaminant

#### DEFINITION

##### WORKPLACE EXPOSURE LIMIT (WEL)

The maximum concentration of an airborne substance, averaged over a reference period, to which workers may be exposed by inhalation.

The purpose of WELs is to put a ceiling in place so that workers will not be exposed to high concentrations of airborne substances (either for short durations of time or for long periods of the working day) where the scientific evidence suggests that there is a risk to health.

WELs have legal status under **COSHH** and can be found listed in the HSE **Guidance Note EH40**. If a WEL is exceeded, then a breach of **COSHH** has taken place; this might lead to enforcement action or prosecution.

**MORE...**

The HSE website includes the current edition of the EH40 *Workplace exposure limits guidance note* at:

[www.hse.gov.uk/pubns/books/eh40.htm](http://www.hse.gov.uk/pubns/books/eh40.htm)

## Short-Term and Long-Term Limits

WELs are **Time-Weighted Average (TWA)** exposures; in other words, they are calculated by measuring a person's average exposure over a specific reference period of time.

The two reference periods of time used are:

- **15 minutes** (called the **Short-Term Exposure Limit (STEL)**).
- **Eight hours** (called the **Long-Term Exposure Limit (LTEL)**).

The reasons for having two limits are:

- STELs combat the ill-health effects of being exposed to very high levels of the substance for short periods of time (minutes).
- LTELs combat the ill-health effects of being exposed to relatively low concentrations of the substance for many or all hours of every working day through an entire working lifetime.

The effects of a short-term exposure may be very different from long-term exposure – some substances could be fatal at high concentrations, while others may cause dizziness and have narcotic effects. For example, high concentrations of solvent vapour may cause a worker to become dizzy and possibly unconscious, while longer-term, lower concentration exposures could result in damage to internal organs, such as the liver.

## The Purpose of Time-Weighted Averages

### DEFINITION

#### TIME-WEIGHTED AVERAGE (TWA)

The average exposure to a contaminant over a specified period of time, such as eight hours or 15 minutes.

Consider a person working with solvents in a manufacturing process:

- They are exposed to short, high-concentration 'bursts' of the substance during certain stages of the work process.
- They are also exposed to background levels of the solvent that are always present in the work area.

The short-term exposures to high concentrations of the solvent are controlled by calculating the concentration over 15-minute periods of time to give a 15-minute TWA exposure. This is then compared to the STEL. If the worker's exposure is below the STEL, then this is legally acceptable. If it is above the STEL, then it is legally unacceptable.

The long-term exposures to background low-level concentrations of the solvent are controlled by calculating the concentration over eight-hour periods of time to give an eight-hour TWA exposure. This is then compared to the LTEL. If the worker's exposure is below the LTEL, then this is legally acceptable. If above, then not.

## Limitations of Exposure Limits

It is important to remember that WELs have their limitations:

- WELs are designed only to control the absorption of harmful substances into the body following inhalation. They are not concerned with absorption following ingestion or through contact with the skin or eyes. So, for example, the concentration of organic solvent in a person's body may be at damagingly high levels, even though the WEL has not been exceeded, because most of the solvent may have been entering through the skin by direct contact with the liquid solvent rather than by inhalation of solvent vapour.
- They take no account of individual personal susceptibility. This is particularly important in the case of substances that produce an allergic response; once a person has become sensitised, the exposure limit designed to suit the average person has no further validity.
- They do not take into account the synergistic (or combined) effects of mixtures of substances (e.g. the use of multiple substances). Some chemicals are harmful individually but much more harmful in combination. One example is asbestos and cigarette smoke – both can cause lung cancer, but the lung cancer risk of an asbestos worker who smokes is multiplied many times (it isn't simply doubly dangerous).
- They may become invalid if the normal environmental conditions are changed (e.g. changes in temperature, humidity or pressure may increase the harmful potential of a substance).
- Some limits do not consider all the possible health effects of a substance (e.g. impact on the skin, such as dermatitis, would not be considered with an airborne limit).

## International Standards

Different standards are applied in different regions of the world.

In the EU, there are Indicative Limit Values (which are included in EH40 in the UK).

In the US alone, several different groups recommend what OELs should be:

- The American Conference of Governmental Industrial Hygienists (ACGIH) sets TLVs, as described above.
- The National Institute for Occupational Safety and Health (NIOSH) recommends Recommended Exposure Limits (RELs).
- The American Industrial Hygiene Association (AIHA) has developed Workplace Environmental Exposure Limits (WEELs).
- The Occupational Safety and Health Administration (OSHA) enforces Department of Labour Permissible Exposure Limits (PELs).

The safe levels of exposure set out above may vary due to different time-measuring periods, different measuring criteria (equipment used), different expected airborne concentrations and various other criteria determining the toxicity of a substance.

It is therefore important to be aware of the relevant limits when working internationally, and to monitor, calculate and compare the measurements to the relevant exposure limits using the correct method.

### Legal Standards

- ILO C170 – Chemicals Convention, 1990 (No. 170).
- ILO R177 – Chemicals Recommendation, 1990 (No. 177).

**STUDY QUESTIONS**

7. Define the term 'workplace exposure limit'.
8. Give two limitations of WELs.

(Suggested Answers are at the end.)

## Control Measures

### IN THIS SECTION...

- Exposure to hazardous substances should be prevented or, if that's not possible, controlled below any relevant Occupational Exposure Limit (OEL).
- A general hierarchy of controls can be applied to controlling exposure:
  - Eliminate or substitute the substances.
  - Change the process.
  - Reduce exposure time.
  - Enclose or segregate.
  - Local Exhaust Ventilation (LEV).
  - Dilution ventilation.
  - Respiratory Protective Equipment (RPE).
  - Other Personal Protective Equipment (PPE).
  - Personal hygiene.
  - Health surveillance, including biological monitoring.
- LEV works by extracting airborne contamination from the place where it is created using an inlet hood linked to a filter and fan by ductwork. Such systems have to be inspected and maintained to ensure their ongoing effectiveness.
- RPE can be subdivided into two groups: respirators (filtering facepiece, half-mask, full-face and power types) and Breathing Apparatus (BA) (compressed air and self-contained types).
- Exposure to carcinogens, mutagens and asthmagens should be prevented. Where this is not possible, exposure must be reduced to as low a level as is reasonably practicable.

## The Need to Prevent or Control Exposure

**Preventing** exposure to hazardous substances is the most effective way of controlling the health risk that they represent.

Where exposure cannot be prevented, it should be **controlled**. If there is an Occupational Exposure Limit (OEL) (e.g. in the UK, a WEL) relevant to the chemical, then exposure must be controlled **below the OEL**.

These two approaches to the management of the health risks created by hazardous substances are required by statute law (such as **COSHH** in the UK).



## Principles of Good Practice

The following eight '**principles of good practice**' exist with regard to controlling exposure to hazardous substances:

- Minimise emission, release and spread of hazardous substance.
- Account for all relevant routes of entry into the body when developing control measures.

- Use exposure control methods that are proportional to health risk.
- Choose the most effective and reliable control options.
- Use PPE in combination with other control measures, if adequate control cannot otherwise be achieved.
- Regularly check and review the control measures that are in place to ensure that they remain effective.
- Provide information and training so that workers are fully aware of the risks presented by exposure and the correct measures to minimise those risks.
- Ensure that any control measures implemented do not increase the overall risks to health and safety.

In the EU and in the UK, these eight 'principles of good practice' exist in statute law (in the UK, specifically Schedule 2A of **COSHH**).

## The Practical Control of Exposure

It is possible to use a **hierarchy of controls** for substances hazardous to health to practically apply the principles of good practice listed above. This is similar to the general hierarchy of controls considered in Element 3.

Prevention of exposure and the associated hierarchy of controls will be addressed in the rest of this section.

### Elimination or Substitution

It may be possible to eliminate or substitute the substance by:

- Eliminating the process or type of work that requires the use of the substance (e.g. outsourcing a paint-spraying operation).
- Changing the way that the work is done to avoid the need for the substance (e.g. screwing rather than gluing).
- Disposing of unused stock of the substance that is no longer required.
- Substituting the hazardous substance for a non-hazardous alternative (e.g. switching from an irritant to a non-hazardous floor cleaner).
- Substituting the hazardous substance for one that has a lower hazard classification (e.g. switching from a corrosive to an irritant).
- Changing the physical form of the substance to one that is less intrinsically harmful (e.g. massive solid rather than powder).

### Process Change

It may be possible to change the process to reduce the risks associated with the substance. For example:

- Applying a solvent by brush rather than by spraying reduces airborne mist and vapour.
- Vacuuming rather than sweeping keeps dust levels down.

### Reduce Exposure Times

There is a simple relationship between the length of time a person is exposed to a hazardous substance and the dose of a substance that they receive: double the time, double the dose; half the time, half the dose. It is therefore sensible to minimise the time period over which people are working with hazardous substances, especially where the hazardous substance can have an acute effect. If a STEL (15-minute TWA) exists for the substance, then this limit must not be exceeded.

## Enclosure and Segregation

It may be necessary to totally enclose the hazardous substance inside process machinery, storage tanks, etc. on a small or large scale. For example, flour dust used in an industrial bakery can be totally enclosed in silos, storage tanks and direct-dosed mixing machinery and moved from one to the other by sealed pipelines. Hundreds of tonnes of flour dust might be handled in this way without the dust escaping into the workplace environment.

Segregating the hazardous substance in the workplace may also be a possibility; it might be stored in a segregated storage area and used in an area away from other work processes and unauthorised personnel.

## Local Exhaust Ventilation

One common control for substances that might become airborne is the use of **Local Exhaust Ventilation (LEV)** systems. A wide variety of different types of LEV is available but the basic principle of a LEV system is the extraction of contaminated air at the point of generation and then the filtering of the contaminant out of the air, allowing the clean air to leave the exhaust and go into the atmosphere.

### TOPIC FOCUS

A **typical LEV system** consists of:

- An **intake hood** that draws air from the workplace in the immediate vicinity of the contaminant.
- **Ductwork** that carries that air from the intake hood.
- A **filter system** that cleans the contaminant from the air to an acceptable level.
- A **fan** of some sort that provides the motive force to move the air through the system.
- An **exhaust duct** that discharges the clean air to the atmosphere.

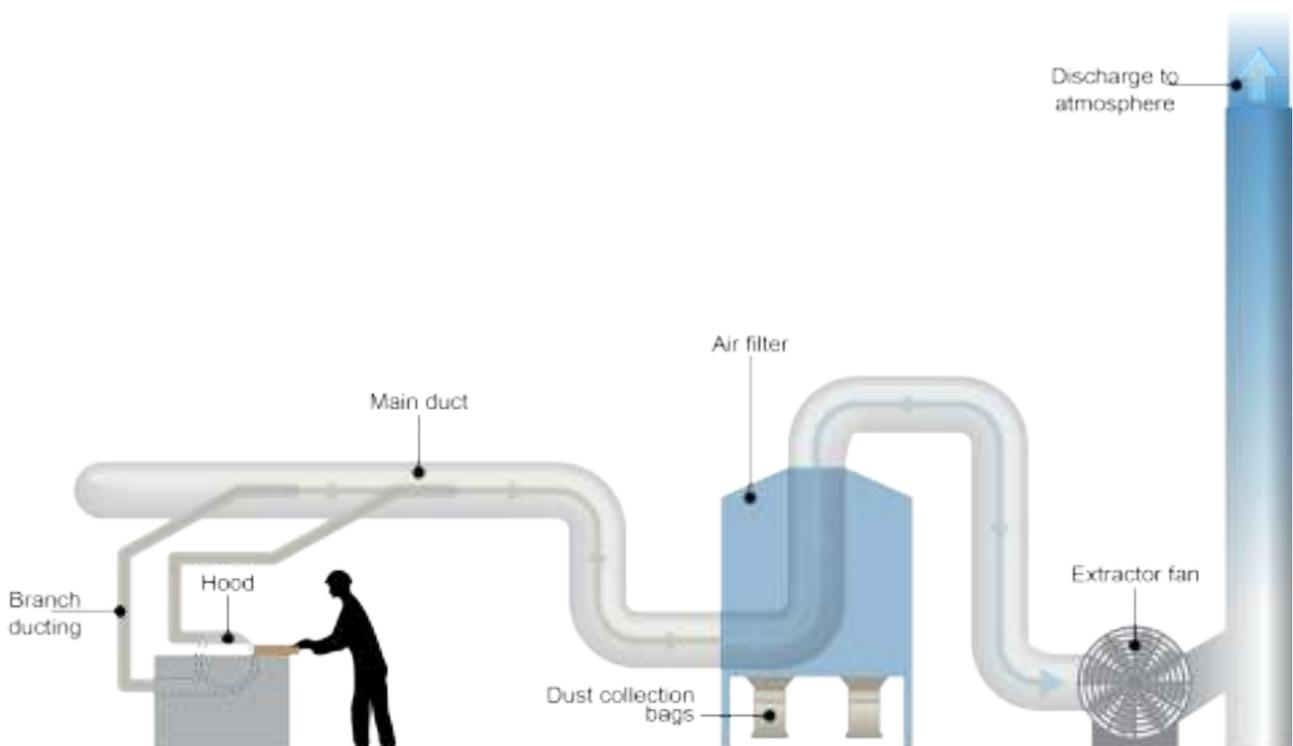

A typical LEV system extracting sawdust from a bench-mounted circular saw

A variety of different intake hoods are used on LEV systems, but they can be categorised into two main types:

- **Captor hoods** – these capture the contaminant by drawing it into the system, overcoming the contaminant's initial velocity (which may have been taking it away from the hood, such as during grinding).
- **Receptor hoods** – these are positioned in such a way that the contaminant is moving in that direction already, so less air movement is required to achieve uptake (e.g. a large intake hood suspended above a bath of molten metal; the metal fume will be hot and rising up into the hood on convection currents).

**Effectiveness** of a LEV system will be **reduced** by:

- Poorly positioned intake hoods.
- Damaged ducts.
- Excessive amounts of contamination.
- Ineffective fan due to low speed or lack of maintenance.
- Blocked filters.
- Build-up of contaminant in the ducts.
- Sharp bends in ducts.
- Unauthorised additions to the system.

LEV systems should be routinely inspected and maintained to ensure their ongoing effectiveness, through:

- **Routine visual inspection** – to check the integrity of the system, signs of obvious damage and build-up of contaminant, both outside and inside the ductwork; filters should be visually inspected to ensure they are not blocked; the exhaust out-feed should be checked.
- **Planned preventive maintenance** – may include replacing filters, lubricating fan bearings and inspecting the fan motor.
- **Periodic testing** – to ensure that air velocities through the system are adequate. This can be done by visual inspection of the intake hood using a smoke stick, measuring air velocities at the intake and in the ductwork using anemometers, and measuring static pressures using manometers and pressure gauges.

Testing of LEV systems on a 14-month basis is a legal requirement under **COSHH**.

### MORE...

Further information on LEV can be found on the HSE website at:

[www.hse.gov.uk/lev](http://www.hse.gov.uk/lev)

## Dilution Ventilation

Dilution ventilation operates by diluting the contaminant concentration in the general atmosphere to an acceptable level by changing the air efficiently in the workplace over a given period of time (e.g. a number of complete changes every hour). These air changes might be **passive**, by providing low-level and/or high-level vents or **active**, using powered fans.

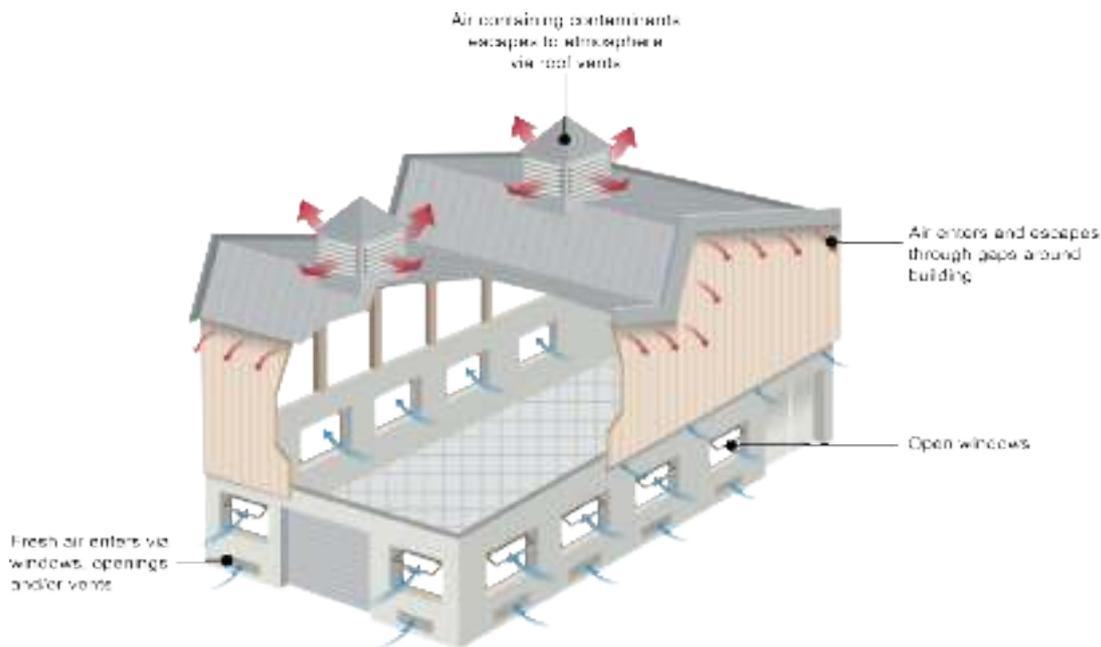

Passive dilution ventilation

The system is intended to remove gas contaminants (sometimes fumes) and keep the overall concentration of any contaminant to below the WEL.

Dilution ventilation is appropriate where:

- The WEL of the harmful substance is high.
- The rate of formation of the gas or vapour is slow.
- Operators are not in close contact with the contamination generation point.

If a powered system is used, fans must be appropriately sited. If the contaminant is:

- **Lighter** than air, it will naturally rise up inside workrooms and can be extracted at high level.
- **Heavier** than air, it will sink to the floor and low-level extraction will be more appropriate.

**Limitations** of dilution ventilation systems are that:

- They are not suitable for the control of substances with high toxicity.
- They do not cope well with the sudden release of large quantities of contaminant.
- They do not work well for dust.
- They do not work well where the contaminant is released at a point source.
- Dead areas may exist where high concentrations of the contaminant are allowed to accumulate. Dead areas are areas in the workplace where, owing to the airflow, air remains relatively motionless and so is not changed. Because non-moving air is not being mixed and diluted with fresh air, high concentrations of hazardous gas or vapour can exist in these dead areas.

## Respiratory Protective Equipment

### DEFINITION

#### RESPIRATORY PROTECTIVE EQUIPMENT (RPE)

Any type of PPE specifically designed to protect the respiratory system, e.g. self-contained BA.

PPE is often used as a control measure when dealing with hazardous substances. The general principles of PPE, its uses and limitations have been presented earlier in Element 3.

Those general principles can be applied to RPE.

There are two main categories of RPE:

- **Respirator** – this filters the air taken from the immediate environment around the wearer.
- **Breathing Apparatus (BA)** – this provides breathable air from a separate source.

### Respirators

There are a variety of types of respirators:

- **Filtering facepiece respirator** – the simplest type, a filtering material held over the nose and mouth by an elastic headband.

This type of respirator is useful to prevent inhalation of dust (and sometimes gas and vapour), but is not suitable for high concentrations of contaminant, for use against substances with high toxicity or for long-duration use.

Use and Benefits	Limitations
Cheap	Low level of protection
Easy to use	Does not seal against the face effectively
Disposable	Uncomfortable to wear

- **Half-mask or ori-nasal respirator** – a rubber or plastic facepiece that fits over the nose and mouth with one or two canisters (cartridges) that contain the filtering material.

This gives a much higher level of protection than the filtering facepiece respirator, but does not protect the eyes.

Use and Benefits	Limitations
Good level of filtration	No built-in eye protection
Good fit achievable	Negative pressure inside the facepiece
Easy to use	Uncomfortable to wear



A worker wears a half-mask respirator to seal asbestos lagging around a pipe

When the wearer inhales, they create negative air pressure inside the facepiece; this means that any leaks in the respirator (e.g. poor seal against the face or a split in the rubber) will allow contaminated air in.

- **Full-face respirator** – similar to the half-mask but has a built-in visor that seals in the eyes and face.

The full-face respirator gives a high level of protection against airborne contaminants and protects the eyes. This can be important where the contaminant can cause eye irritation or be absorbed through the eye.



A full-face respirator with filtering canister (or cartridge)

Use and Benefits	Limitations
Good level of filtration	Restricts vision
Good fit achievable	Negative pressure inside the facepiece
Protects the eyes	Uncomfortable to wear

- **Powered respirator** – a powered fan that blows filtered air to the wearer. Usually made up of a helmet and face visor, with the air blown down over the face from the helmet.

This type of respirator does not have a tight seal with the wearer's face and is especially suited to dusty, hot environments where the stream of air moving over the face is a benefit.

Use and Benefits	Limitations
Intermediate level of filtration	Heavy to wear
Air movement cools wearer	No tight face seal
Air stream prevents inward leaks	Limited battery life

## Breathing Apparatus

There are two common types of BA:

- **Compressed airline BA** – air is supplied down a small-bore hose at high pressure. Supply can be from a certified breathing air compressor or from cylinders of air on a trolley. Pressure is then stepped down by a regulator and air supplied at low pressure to the user's face mask. It is commonly seen in areas such as spray paint booths.

Use and Benefits	Limitations
Supply of air is not time-restricted if a compressor is used	Hose can be long, but not endless
Positive pressure inside the facepiece	
Wearer is not burdened with cylinder	

- **Self-contained BA** – breathable air is supplied from a pressurised cylinder worn by the user.

This type of BA gives the wearer complete freedom of movement, but it is the most heavy and bulky type and the air cylinder does have a limited capacity.

Use and Benefits	Limitations
Complete freedom of movement	Supply of air is time-restricted
Positive pressure inside the facepiece	Equipment is bulky and heavy
	More technical training is required



A fire-fighter wearing a self-contained BA and other PPE

## Selection, Use and Maintenance of Respiratory Protective Equipment

RPE must be selected carefully to ensure that it is suitable.

### TOPIC FOCUS

Factors affecting the suitability of RPE include the:

- Concentration of the contaminant and its hazardous nature.
- Physical form of the substance (e.g. dust or vapour).
- Level of protection offered by the RPE.
- Presence or absence of normal oxygen concentrations.
- Duration of time that it must be worn.
- Compatibility with other items of PPE that must be worn.
- Shape of the user's face and influence on fit.
- Facial hair that might interfere with an effective seal.
- Physical requirements of the job, such as the need to move freely.
- Physical fitness of the wearer.

The level of protection offered by an item of RPE is usually expressed as the **Assigned Protection Factor (APF)**. This is simply a measure of how well the RPE keeps out the contaminant.

Any RPE selected must meet relevant standards (e.g. it must be CE-marked).

Users of RPE should receive appropriate information, instruction and training. In particular, they should understand:

- How to fit the RPE.
- How to test it to ensure that it is working effectively.
- The limitations of the item.
- Any cleaning requirements.
- Any maintenance requirements (e.g. how to change the filter).

Arrangements should be made to maintain RPE in line with manufacturers' instructions and any legal standards that might exist. This should include the need to repair or replace damaged items. Maintenance should only be carried out by competent personnel.

## Other Personal Protective Equipment

There are other types of PPE routinely used to give protection against hazardous substances.

### Hand Protection

**Gloves** (short-cuff) and **gauntlets** (long-cuff) can give protection against:

- Chemicals (e.g. acids, alkalis and solvents).
- Biological agents (e.g. viruses in blood).
- Physical injury (e.g. a knife cut with associated infection risk).

Where protection against chemicals is concerned, care must be taken to ensure that the material that the gloves are made from is suitable for the chemical in question.

### Eye Protection

Three different types of eye protection are commonly used to protect the eyes from hazardous substances:

- **Safety spectacles** – these offer a degree of front and side protection but do not completely encase the eye.
- **Safety goggles** – these completely encase the eye and offer better splash and impact resistance.
- **Face visors** – these cover the eyes and face, so offering a higher degree of protection.

### Body Protection

The body can be protected from hazardous substances by the use of a range of clothing, such as:

- Overalls (prevent direct skin contact with agents such as grease).
- Aprons (prevent spills and splashes from getting onto normal work wear and soaking through to skin).
- Whole-body protection (the entire body is encased in a protective chemical-resistant suit).



A laboratory worker uses nitrile gloves to prevent contact with chemical reagents being handled in a fume cupboard



A face visor offers eye and full-face protection in the event of splashes



Workers wearing chemical suits respond to an emergency spill

## Personal Hygiene and Protection Regimes

Personal hygiene is often critical to prevent exposure to hazardous substances. Many biological agents and some hazardous chemicals are put onto the skin or into the mouth by cross-contamination. For example, a laboratory worker's hands become contaminated with bacteria in the laboratory; they then touch their nose or mouth and the bacteria have direct access. Alternatively, food or cigarettes can be cross-contaminated by hand contact and then put into the mouth.

It is essential that good hygiene practices are adopted, as appropriate, such as:

- Hand-washing routines when leaving workrooms.
- Careful removal and disposal of potentially contaminated PPE to prevent cross-contamination to normal clothes.
- Prohibition of eating, drinking and smoking in work areas.

This will require the provision of appropriate washing facilities (water, soap and drying equipment), PPE and work clothes-changing facilities, along with rest and food preparation areas.

In some instances, it may be possible to vaccinate workers against certain biological agents, for example vaccination against hepatitis B is often provided to first aiders on a voluntary basis.

There are many issues to consider before embarking on a vaccination programme:

- Worker consent must be obtained.
- Vaccination does not always grant immunity.
- Vaccination can give workers a false sense of security.

In most situations, vaccination should only be offered when indicated by law, code of practice or guidance.

## Health Surveillance

Health surveillance is a system of ongoing health checks, and often involves carrying out some form of medical examination or test on workers who are exposed to substances such as solvents, fumes, biological agents and other hazardous substances.

**Note:** similar health checks may be required for those exposed to noise, vibration, etc., and are covered in other elements.

Health surveillance is important to enable early detection of ill-health effects or diseases, and also helps employers to evaluate their control measures and educate workers. The risk assessment will indicate where health surveillance may be needed, but it is required where:

- there is an adverse health effect or disease linked to a workplace exposure; and
- it is likely that the health effect or disease may occur; and
- there are valid techniques for detecting early signs of the health effect or disease; and
- the techniques themselves don't pose a risk to workers.



Without hand-washing facilities this worker is at risk of cross-contamination from chemical and biological agents



Vaccination can confer immunity against specific biological agents

There are **two types of health surveillance** commonly carried out:

- **Health monitoring** – where the individual is **examined for symptoms and signs of disease** that might be associated with the agent in question. For example, a worker in a bakery might have a lung function test to check for signs of asthma; flour dust is a respiratory sensitiser capable of causing occupational asthma.
- **Biological monitoring** – where a **blood, urine or breath sample is taken** and analysed for the presence of the agent itself or its breakdown products. For example, a worker in a car battery manufacturing plant might have a blood sample taken to test for the levels of lead in the bloodstream.

When necessary, health surveillance should be conducted on first employment, to establish a 'baseline', and then periodically. It can also be done when a person leaves employment as a final check. The need for health surveillance is usually subject to regulations, codes of practice and guidance.

### MORE...

There is a range of industry-specific guidance on health surveillance at:

[www.hse.gov.uk/health-surveillance](http://www.hse.gov.uk/health-surveillance)

## Further Control of Carcinogens, Mutagens and Asthmagens

### DEFINITIONS

#### CARCINOGEN

A substance that can induce the growth of malignant tumours (cancer tumours capable of causing serious ill health or death).

#### MUTAGEN

A substance that can cause changes (mutations) in the genetic material (DNA) of a cell, leading to heritable genetic defects.

#### ASTHMAGEN

A substance that is related to the development of asthma symptoms.

Exposure to carcinogens, mutagens and asthmagens should be prevented, but if this is not reasonably practicable, then control of exposure to the substance would only be considered acceptable if:

- the WEL had not been exceeded;
- the eight principles of good practice had been used; and
- exposure had been reduced to **As Low As is Reasonably Practicable (ALARP)**.

To achieve this, the following should be applied:

- Total enclosure of process and handling systems, unless this is not reasonably practicable.
- Prohibition of eating, drinking and smoking in potentially contaminated areas.
- Regular cleaning of floors, walls and other surfaces.

- Designation of areas that may be contaminated with the use of warning signs.
- Safe storage, handling and disposal.

#### Legal Standards

- ILO C170 – Chemicals Convention, 1990 (No. 170).
- ILO R177 – Chemicals Recommendation, 1990 (No. 177).
- ILO C139 – Occupational Cancer Convention, 1974 (No. 139).
- ILO R147 – Occupational Cancer Recommendation, 1974 (No. 147).

#### STUDY QUESTIONS

9. Identify the principles of control illustrated by the following measures:
  - (a) Using granulated pottery glazes instead of powders.
  - (b) Vacuum cleaning rather than sweeping up with a broom.
  - (c) Job rotation.
  - (d) Using water-based adhesives rather than solvent-based ones.
10. Outline the difference between local exhaust ventilation and dilution ventilation.
11. Outline what 'dead areas' are and why they are a problem for dilution ventilation systems.
12. Identify the four main types of respirator and the two main types of breathing apparatus.
13. Identify some important criteria in the selection of the appropriate respirator to use.
14. Outline the main purpose of routine health surveillance.

(Suggested Answers are at the end.)

## Specific Agents

### IN THIS SECTION...

- Asbestos causes several serious ill-health conditions: asbestosis, lung cancer, mesothelioma and pleural plaques.
- Those responsible for the repair and maintenance of premises have a duty to manage asbestos on those premises. This duty involves identifying Asbestos-Containing Materials (ACMs), recording their locations and condition, assessing the risks of exposure, making and implementing an asbestos management plan, and providing information to those who might potentially be exposed.
- Other hazardous substances that can cause severe ill health include: Blood-Borne Viruses (BBVs) (such as the hepatitis B virus), carbon monoxide (CO) (that can cause asphyxiation), cement (may cause corrosive burns), *Legionella* bacteria (cause Legionnaires' disease), *Leptospira* bacteria (cause leptospirosis), silica (causes silicosis) and wood dust (may cause asthma or nasal cancer).

## Asbestos

Asbestos is a generic name given to a collection of naturally occurring minerals that have been used extensively as fire-resistant building and insulating materials. Asbestos has excellent heat resistance characteristics and is chemically inert. The three main forms of asbestos are blue (known as crocidolite), brown (amosite) and white (chrysotile). Historically, it has been incorporated into many building parts such as roofs (asbestos cement), ceilings (ceiling tiles), walls and ceilings (in fire breaks), floors (floor tiles), pipes (downpipes), decorative plasters ('artex') and insulation (pipe lagging). It may also be found as asbestos rope or gaskets in old equipment, such as furnaces, chemical pipework or boilers. Material that has asbestos incorporated into it is called an **Asbestos-Containing Material (ACM)**.



Asbestos

## Health Risks Associated with Asbestos

Asbestos is hazardous by inhalation.

Four forms of disease are associated with asbestos exposure:

- **Asbestosis** – where asbestos fibres lodge deep in the lungs and cause scar tissue formation. If enough of the lung is scarred, then severe breathing difficulties occur. It can prove fatal, as well as increase the risk of cancer.
- **Lung cancer** – asbestos fibres in the lung trigger the development of cancerous growths in the lung tissue. It is usually fatal.
- **Mesothelioma** – asbestos fibres in the lung migrate through the lung tissue and into the cavities around the lung and trigger the development of cancerous growths in the lining tissue. It is always fatal.
- **Diffuse pleural thickening** – thickening of the lining tissue of the lung (sometimes known as 'pleural plaques') that causes breathing difficulties. It is not fatal.

The symptoms of these diseases do not become apparent until years after exposure has occurred (10–15 years for asbestosis and 30–40 years for mesothelioma).

Though asbestos use is now banned in many countries such as the UK, it remains a serious health risk as it is still present in many buildings.

Any work on existing structures where asbestos is present involves the potential to disturb asbestos. Demolition, refurbishment, installation and even minor repair work can expose workers to asbestos by inhalation.

Legal frameworks for the management of asbestos vary depending on country and region. The practical controls created by the legal framework in the UK.

Where work involves disturbing ACMs (e.g. construction or refurbishment work) then, in most instances, the ACMs should be removed prior to the work commencing. In Great Britain, such work is subject to the **Control of Asbestos Regulations 2012** and, in most instances, must be carried out by an **HSE-licensed contractor**.

## Managing Asbestos in Buildings

The occupiers and owners of buildings should be aware of the presence of asbestos, and the **Control of Asbestos Regulations 2012** require them to put in place an **asbestos management plan** and hold an **Asbestos Register**.

### TOPIC FOCUS

The duty to manage asbestos involves:

- Identifying asbestos and potential ACMs so that their location and condition is known.
- Assuming that if materials exist in the building that have the potential to contain asbestos, but the presence of asbestos has not been proven, that they are ACMs.
- Making and keeping an up-to-date record (Asbestos Register) with details of these materials.
- Assessing the risks of anyone being exposed to asbestos fibres from these materials.
- Making and implementing an asbestos management plan to manage the risks from these materials.
- Providing information to anyone who is likely to work on or disturb the ACMs (such as contractors working in an area where ACMs have been identified).

Identifying ACMs in a building usually involves some form of survey. Sometimes, samples have to be taken for analysis. Conducting a survey can be done in-house, by competent people, but in many instances must be done by an external **competent surveyor**.

Where ACMs are in a:

- **Good condition** (i.e. the asbestos fibres in the material are not free to leave and form an airborne dust) then they can be **labelled** (where possible) but left undisturbed.
- Damaged but **acceptable condition** (i.e. the ACM is damaged but the asbestos fibres in the material are not free to leave and form an airborne dust) then they can be **encapsulated** (covered and made safe), labelled and left in place.
- **Poor condition** (i.e. the asbestos fibres are loose and can become airborne), or **likely to be disturbed**, they should be **removed**.

Work on ACMs, such as encapsulation, repair or removal work, must always be done by competent people using appropriate work methods and precautions. For low-risk work, this might be any suitably competent person. For other types of work, it must be carried out by an **HSE-licensed contractor**.

## Blood-Borne Viruses

There are many viruses that can be transferred from one person to another by transfer of blood and other body fluids. Perhaps the best known of these Blood-Borne Viruses (BBVs) are hepatitis and Human Immunodeficiency Virus (HIV, the causative agent of Acquired Immune Deficiency Syndrome (AIDS)). Hepatitis B and C present the greatest risk in the workplace, so will be used as an example.

There are several forms of hepatitis (A, B, C, etc.) caused by different strains of the virus. The route of infection depends on the virus type (e.g. hepatitis A is contracted orally by cross-contamination with faecal material containing the hepatitis A virus, so sewage workers are at risk).

**Hepatitis B** and **C** are transmitted in body fluids, such as blood, so occupations at risk would include healthcare workers (doctors and nurses), fire-fighters, police and waste disposal workers. The virus survives for long periods outside the body and can survive harsh treatment that would kill other microorganisms (such as boiling in water). Contaminated body fluids can cause infection by contact with damaged skin, needle-stick injury and even splashing to the eyes and mouth.

Symptoms of the disease include jaundice and liver damage. Though many people are able to make a full recovery, some will become long-term sufferers and some will continue to carry the virus but do not display any symptoms of infection.

Typical controls include:

- The use of PPE, such as gloves and eye protection when handling potentially contaminated material.
- Correct disposal of potentially contaminated material such as clinical waste.
- Prevention of needle-stick injuries by correct disposal of sharps in a sharps bin.
- Decontamination and disinfection procedures.
- Vaccination where appropriate.
- Procedures to deal with accidental exposures (e.g. needle-stick injury).

### MORE...

Further information on BBVs can be found at:

[www.hse.gov.uk/biosafety/blood-borne-viruses](http://www.hse.gov.uk/biosafety/blood-borne-viruses)

## Carbon Monoxide

Carbon monoxide (CO) is a colourless, odourless gas usually encountered as a by-product of partial combustion (e.g. a poorly maintained heating boiler). It is hazardous by inhalation.

During normal respiration, oxygen from the atmosphere is absorbed by the red blood cells in the blood and chemically bound to haemoglobin (a protein) so that it can be carried around the circulatory system to body tissues. CO interferes with this oxygen-carrying process by binding onto the haemoglobin molecule at the same place where the oxygen should be. This prevents oxygen transportation and can lead to death by **asphyxiation**. Low levels of CO (0.005%) will cause a progressively worsening headache. Levels of 1.3% will cause immediate unconsciousness and death within three minutes. Note that this can occur even though oxygen concentrations are normal at 21%.

Typical controls include:

- Restricting work on gas systems to competent engineers only.
- Maintenance and testing of boilers and flues.
- Good general workplace ventilation.
- LEV for vehicle exhausts in workshops.
- Care in the siting of equipment containing combustion engines.
- CO alarms.
- Confined space entry control.

### MORE...

Further information on CO can be found at:

[www.hse.gov.uk/gas/domestic/co.htm](http://www.hse.gov.uk/gas/domestic/co.htm)

## Cement

Cement is used extensively in the construction industry to make mortar and concrete. In its dry powder form, it is an **irritant** dust, easily inhaled or blown into the eyes. Once mixed with water, it is **corrosive** on the skin and in the eyes.

Workers can be exposed to cement during:

- Mixing operations – in both the dry powder and mixed, wet form.
- Bricklaying and concrete pouring – in the wet form.

The harmful effects of exposure include:

- Irritation or corrosive burns to the eyes.
- Irritation of the respiratory tract.
- Irritant **dermatitis** on skin contact.
- Allergic dermatitis on repeated skin contact.
- Corrosive burns to the skin on prolonged contact.

Typical controls include:

- Eliminating or reducing exposure.
- Use of work clothing and PPE, such as gloves, dust masks and eye protection.
- Removal of contaminated clothing.
- Good hygiene and washing on skin contact.



Cement is a commonly used product for construction

## Legionella Bacteria

*Legionella* bacteria are water-loving soil bacteria that are found naturally in the environment. The bacteria are hazardous when inhaled into the lungs, where they cause **Legionnaires' disease** (also called 'legionellosis').

This can occur when water systems in a workplace become contaminated with the bacteria (which breed in warm conditions) and then that contaminated water is sprayed to create a mist (with living bacteria inside the droplets). The most common sources for outbreaks of the disease are outdoor cooling towers associated with air-conditioning systems. Water containing the bacteria is sprayed inside the cooling tower, then drifts out of the top of the cooling tower and is inhaled by passers-by. These people may then develop the disease.

Symptoms start as 'flu-like (fever, headache, muscle pain, etc.) and then progress to **pneumonia**. The disease can prove fatal, especially for the elderly, infirm or immuno-suppressed, or if not diagnosed early.

Typical controls include:

- **Management Controls**

- Assessment of the risk from *Legionella*.
- A written control scheme (see below).
- Appointment of a 'responsible person' to carry out a risk assessment, manage and implement the written scheme of controls.
- Review of control measures.

There are also duties placed on those involved in the supply of water systems.

- **Practical Controls**

- Avoid water temperatures between 20°C and 45°C and conditions that favour bacteria growth.
- Avoid water stagnation which can encourage biofilm growth.
- Avoid using material that can harbour bacteria and provide them with nutrients.
- Control the release of water spray.
- Keep water, storage systems and equipment clean.
- Use water (chemical) treatments where necessary.
- Carry out water sampling and analysis.
- Ensure correct and safe operation and maintenance of water systems.

### MORE...

Further information on *Legionella* including the codes of practice L8, *Legionnaires' disease – The control of Legionella bacteria in water systems*, is available at:

[www.hse.gov.uk/legionnaires](http://www.hse.gov.uk/legionnaires)

## Leptospira Bacteria

*Leptospira* bacteria commonly infect animals such as rats, mice, cattle and horses. Rats and cattle are significant carriers of the disease **leptospirosis**.

Infected rats pass the bacteria in their urine, perhaps onto wet surfaces or into water where the bacteria can stay alive. If contaminated water comes into contact with cuts or grazes, or is ingested, then infection may occur. Occupations at risk are those where people work with potentially infected animals (e.g. dairy farmers) or in wet areas where there may be rats (e.g. sewer workers or water sports instructors).

**Leptospirosis** starts with 'flu-like symptoms and then progresses to a more serious phase involving jaundice. At this stage, it causes liver damage and may be known as **Weil's disease**. If diagnosed early, this disease is usually treated successfully. It can prove fatal, especially if diagnosed late.

Typical controls include:

- Preventing rat infestation by good housekeeping and pest control.
- Good personal hygiene (e.g. hand-washing).
- PPE (especially gloves).
- Covering cuts and grazes.
- Issuing workers with an 'at risk' card to be shown to a GP to allow early diagnosis.



Rats are the main carrier of the *Leptospira* bacteria

### MORE...

Further information on leptospirosis is available at:

[www.hse.gov.uk/construction/healthrisks/hazardous-substances/harmful-micro-organisms/leptospirosis-weils-disease.htm](http://www.hse.gov.uk/construction/healthrisks/hazardous-substances/harmful-micro-organisms/leptospirosis-weils-disease.htm)

## Silica

### DEFINITION

#### SILICA

A crystalline mineral component of rock commonly encountered in the mining, quarrying, pottery and construction industries. Commonly known as 'quartz'.

Silica is hazardous by inhalation. When inhaled, **respirable crystalline silica** dust is deposited deep in the lungs where it causes scar tissue to form (silicosis is very similar to asbestosis). This progressive disease leads to breathlessness and chest pain, and can prove extremely disabling and fatal causing heart and lung failure.

Typical controls include:

- Prevention of exposure by using alternative work methods.
- Dust suppression by water jet/spray.

- LEV.
- RPE.
- Health surveillance (lung function test and chest X-ray).

### MORE...

The following link provides more details on silicosis:

[www.hse.gov.uk/lung-disease/silicosis.htm](http://www.hse.gov.uk/lung-disease/silicosis.htm)

## Wood Dust

Wood dust is hazardous on inhalation and causes **asthma**. All wood dusts cause irritation to the respiratory system. Certain types of wood dust are more likely to cause asthma than others and are therefore categorised as asthmagens.

Hardwood dusts can cause nasal cancer (cancer of the nasal cavity behind the nose). Again, certain types of hardwood are more strongly associated with the risk of cancer and are therefore recognised as carcinogens. Workers in the woodworking industry are most at risk of exposure to wood dust.

Typical controls include:

- LEV systems.
- The use of vacuuming to clean up dust (not sweeping).
- RPE.
- Health surveillance (usually annual questionnaires).

In **all** of the examples given above, **COSHH** requires:

- Risk assessment of potential exposure.
- Prevention or control of exposure.
- Maintenance of the various control measures used.
- Provision of information, instruction and training for workers.

### Legal Standards

- ILO C170 – Chemicals Convention, 1990 (No. 170).
- ILO R177 – Chemicals Recommendation, 1990 (No. 177).
- ILO C162 – Asbestos Convention, 1986 (No. 162).
- ILO R172 – Asbestos Recommendation, 1986 (No. 172).

**STUDY QUESTIONS**

15. Outline how carbon monoxide (CO) is hazardous to health.
16. Identify three diseases associated with asbestos exposure.
17. Outline how cement is hazardous to health.

(Suggested Answers are at the end.)



## Summary

---

This element has dealt with some of the hazards and controls relevant to hazardous substances in the workplace.

In particular, this element has:

- Outlined the different physical forms of chemicals (solids, dusts, fumes, gases, mists, vapours and liquids) and biological agents (fungi, bacteria and viruses) that can be hazardous to health.
- Identified the meaning of the terms 'acute' and 'chronic' when used to describe the effects of hazardous chemicals and outlined their classification (acute toxicity, skin corrosion/irritation, eye corrosion/irritation, respiratory or skin sensitisation, carcinogenicity/mutagenicity/reproductive toxicity, and specific target organ toxicity).
- Explained the main routes of entry into the body (inhalation, ingestion, absorption through the skin and injection through the skin).
- Noted some principles for assessing risk from exposure to hazardous substances and the sources of information used (especially product labels, manufacturers' safety data sheets and guidance notes such as EH40).
- Identified the requirement to undertake basic monitoring to assess concentrations of hazardous substances in the workplace.
- Outlined the principle of OELS, such as WELs, and the purpose of STELs and LTELs.
- Outlined the principles of good practice for controlling exposure.
- Described a hierarchy of controls for hazardous substances: eliminate or substitute the substances, change the process, reduce exposure time, enclose or segregate, LEV, dilution ventilation, RPE, other PPE, personal hygiene and health surveillance.
- Outlined basic principles of LEV and dilution ventilation.
- Described types of RPE: respirators (filtering facepiece, half-mask, full-face and power types) and BA (compressed air and self-contained types).
- Described the ill-health effects of asbestos, various chemicals (e.g. CO) and biological agents (e.g. *Legionella*) found in workplaces, and the general controls required.

# Practical Assessment Guidance

## Part 2 – Risk Assessment (Continued)



In the Practical Assessment Guidance at the end of the last element, we looked at the first two columns of the risk assessment table (Part 2 of the form) that you are required to complete: hazard categories and hazards, and who might be harmed and how.

In this part of the guidance, we will look at the middle two columns of this risk assessment table: existing control measures and additional control measures required.

### The Part 2 Form (Continued)



**Part 2: Risk Assessment**

Organisation name:  
Date of assessment:  
Scope of risk assessment:

Hazard category and hazard	Who might be harmed and how?	What are you already doing?	What further controls/actions are required?	Timescale for further actions to be completed (weeks)	Responsible person's job title

Learner number:

Learner name:

Page 2 of 3

**Note:** These forms are for reference purposes only. Please visit the NEBOSH website to obtain the official forms to submit your assessment.

The next step in completing the risk assessment is to identify what control measures are currently in place to manage the risk created by each hazard. If these control measures are inadequate, you must identify what additional control measures are necessary to manage the risk down to an acceptable standard.

There are two columns to record this information on the Part 2 Form: column 3 and 4. Column 3 'What are you already doing?' is for existing control measures; column 4 'What further controls/actions are required?' is for additional controls. These two columns clearly work in unison. So, if very little is currently being done to manage the risk created by a particular hazard, then the expectation is that additional control measures are required. Conversely, if all of the appropriate control measures are already in place, then very few additional controls will be required to manage the risk.

### Column 3: What Are You Already Doing?

Do not be misled by the column 3 heading 'What are you already doing?'. This is not a question directed at you personally. It is a question aimed at the organisation. So you do not need to write a list of all of the things that you have personally done so far to manage the risk created by each hazard. Legal standards, codes of practice. Instead, you need to write a brief explanation of all of the current control measures that are in place.

Remember that some of the control measures will be physical things such as guards on machinery, PPE worn by workers, LEV systems to extract hazardous airborne contaminants and convex mirrors at vehicle intersections. But also remember that many of the control measures will be administrative or procedural, such as a SSW for a particular maintenance task, worker training, maintenance programmes on items of equipment and pre-use checks on vehicles. And some control measures will involve health surveillance, such as hearing tests (audiometry) for workers in high-noise areas.

You need to include all of the current control measures that are relevant to the hazard in question. This means that you might have to do some research to find out the full range of control measures. You might do this by talking to workers, talking to managers, looking at policy documents and records and/or carrying out inspections in the relevant area. If you do carry out any of these activities, remember to write about them in the methodology section (Box 2) of the practical assessment in Part 1.

If your investigations show that some controls are working well, then state this. If they are not working well, then say so. If things are being done sporadically or on an ad hoc basis, then say so. The examiner is looking for an honest appraisal of the existing control measures.

The key here is that you include enough information about the existing control measures so that the examiner can see what is being done and can make a judgement about their suitability. So you need to briefly describe what is being done, demonstrating that you are able to do a suitable risk assessment. Don't just write single words or very short phrases and don't simply refer to in-house risk assessments repeatedly as the only control measure.

Once you have described all of the existing control measures for all of your chosen hazards, you then need to describe the additional controls required (column 4).

### Column 4: What Further Controls/Actions Are Required?

Before you fill in column 4, ask yourself if you know what the relevant standards are for each hazard and what all of the control measures would ideally be. So for each hazard: do you know what the legal standard is? Do you know what any relevant code of practice says? And do you know what best practice looks like?

You might have a very good understanding of legal requirements and best practice for a particular hazard. Or you may need to do some research, using your study text and online sources (such as the HSE website), to discover exactly what the legal standard is for a specific hazard and/or what the best practice guidance is. Again, if you do this kind of research, remember to include it in the methodology section (Box 2) of the Part 1 form.

Legal standards, codes of practice and best practice are very useful because you can use them as a benchmark for your workplace risk assessment. For example, the law requires that hearing (audiometry) tests should be carried out on all workers working in a high-noise area (where daily exposure to noise is more than 85 dB(A)). If your workplace is not providing this health surveillance, then you can identify audiometry as an additional control measure required by law. If the code of practice requires that forklift-truck drivers are trained to an industry standard, but your organisation is not doing this, then you can easily identify proper operator training as a further action required. If the relevant guidance document states that LEV must be used when handling a particular hazardous substance indoors in quantities over 1 litre, but your workplace does not have a LEV in place, then you can recommend LEV as an additional control measure.

In column 4, you must briefly describe what additional control measures need to be introduced to further control the risks created by your chosen hazards. Understanding the legal standards, codes of practice and guidance will enable you to identify and recommend the right control measures (especially when your organisation already has lots of control measures in place but some may not be quite right).

Do not write about control measures that are not relevant to the specific hazard in question or are disproportionate to the risks involved. The examiner wants to see that you can identify practical and realistic control measures that will address real risks in the workplace. They are not interested in fanciful or over-the-top risk-averse recommendations.

For example, if you state that inadequately guarded scaffolds are being built on site by your workers and this needs to be addressed by sending these workers on a scaffolding course and training someone in management as a scaffold inspector, then this sounds sensible and appropriate. Conversely, if you state that there are small tears and stains on an office carpet so the office needs to be closed for 6 months while a refurbishment takes place, then this sounds disproportionate and over-the-top.

Remember that the examiner will be looking at column 3 in conjunction with column 4 and they will be asking themselves if the current and further control measures that you have described adequately control the hazard identified.

When you are writing further actions required into column 4, you might find it useful to give each action a reference number (1, 2, 3, 4, etc.). This can help you when you get to the allocation of responsibilities task later (column 6 of Form 2).

**Note:** risk assessment methodology used in the practical assessment does not need a risk rating and does not need to mention likelihood or severity scoring. You are making a qualitative assessment using the law, codes of practice and guidance as the standards to judge the adequacy of control measures. So do not make any use of, or reference to, likelihood scores, severity scores or risk rating in this part of the assessment. And do not make use of any in-company risk assessment methodology that uses these or any form of risk-rating matrix.

We will now turn our attention to the last two columns of the risk assessment table at the end of Element 8.



# General Workplace Issues



## Learning Objectives

Once you've studied this element, you should be able to:

- 1 Describe common health, welfare and work environment requirements in the workplace.
- 2 Describe the hazards and control measures for safe working at height.
- 3 Describe the safe work practices for working within confined spaces.
- 4 Describe the hazards and controls associated with lone working.
- 5 Describe the main causes of and controls for slips and trips in the workplace.
- 6 Describe the hazards and control measures for the safe movement of people and vehicles in the workplace.
- 7 Describe the control measures for work-related driving and the hazards associated with electric and hybrid vehicles.

<b>Health, Welfare and Work Environment Requirements</b>	<b>8-3</b>
Welfare Provision	8-3
Work Environment Requirements	8-4
Exposure to Extremes of Temperature	8-4
<b>Working at Height</b>	<b>8-7</b>
Introduction to Working at Height	8-7
Risk Factors for Work at Height	8-8
Controlling the Risks of Work at Height	8-10
Avoiding Work at Height	8-10
Preventing Falls and Falling Materials	8-11
Minimising Distance and Consequences of a Fall	8-14
Provision of Equipment, Training and Instruction	8-14
Safe Working Practices for Access Equipment	8-15
<b>Working in Confined Spaces</b>	<b>8-24</b>
Introduction to Confined Spaces	8-24
Factors to be Assessed	8-25
<b>Lone Working</b>	<b>8-29</b>
Introduction to Lone Working	8-29
Risk Assessment Factors for Lone Working	8-29
Safe System of Work for Lone Working	8-30
<b>Slips and Trips</b>	<b>8-32</b>
Common Slipping and Tripping Hazards	8-32
Control Measures for Slips and Trips	8-33
<b>Safe Movement of People and Vehicles in the Workplace</b>	<b>8-37</b>
Risks Associated with Workplace Transport Operations	8-37
Workplace Transport Control Measures	8-40
<b>Work-Related Driving</b>	<b>8-46</b>
Managing Work-Related Road Safety	8-46
Risk Assessment Factors	8-47
Evaluating the Risks	8-48
Control Measures	8-48
Hazards of Electric and Hybrid Vehicles	8-51
<b>Summary</b>	<b>8-52</b>
<b>Practical Assessment Guidance</b>	<b>8-54</b>

# Health, Welfare and Work Environment Requirements

## IN THIS SECTION...

- Minimum welfare provision means ensuring that workers have access to drinking water, sanitary conveniences, washing facilities, changing rooms, accommodation for clothing, and rest and eating facilities.
- Workplace environment issues that affect worker health include the provision of suitable seating, ventilation, heating and lighting.
- Working in extreme temperatures can cause health effects such as dehydration, heat stress and heat stroke, and hypothermia and frostbite. These ill-health effects can be managed by controlling the environment, providing frequent breaks and facilities, Personal Protective Equipment (PPE) and training.

## Welfare Provision

This section outlines the good practice requirements for basic welfare provision in workplaces. These requirements are subject to legal standards, for example those set by the EU directive transposed in the UK as the **Workplace (Health, Safety and Welfare) Regulations 1992**. The **Construction (Design and Management) Regulations 2015** establish similar standards for construction sites. (Note that first aid is often considered to be part of an employer's welfare provision; this topic is covered in Element 3.)

### TOPIC FOCUS

Minimum welfare standards include:

- **Drinking water** – access to wholesome drinking water. If non-potable water is also available then supplies should be clearly labelled to distinguish between the two.
- **Sanitary conveniences** – access to a sufficient number of sanitary conveniences (e.g. WCs) for the number of workers present with separate facilities for men and women. The conveniences should be protected from the weather and be adequately clean, lit and ventilated. Special provision should be made for the disabled.
- **Washing facilities** – access to suitable washing facilities by sanitary conveniences, changing facilities and as required in work areas. Showers may be necessary if the work is dirty, strenuous or involves potential contamination with hazardous substances. Washing facilities should have hot and cold (or warm) running water, soap and towels (or other means of drying).
- **Changing rooms** – provision of suitable changing facilities if workers have to change into special workwear which involves significant undressing. These should be adequately lit, clean and ventilated, with separate facilities for men and women.
- **Accommodation for clothing** – provision of lockers or other storage facilities where workers have to change for work so that their personal clothing can be kept clean and secure. Separate storage for dirty work clothing may be necessary to prevent cross-contamination.
- **Resting and eating facilities** – access to suitable rest areas where workers can take a break from work. Such areas should have sufficient seating and be away from hazardous work areas, allowing workers to remove PPE and relax. Eating facilities should be provided so that food can be eaten in a hygienic environment. If hot food is not provided at work then basic facilities might be provided so workers can make their own hot drinks and food. Separate facilities may need to be provided for new and expectant mothers. Non-smoking facilities should be available to protect workers from second-hand smoke. (Note that smoking in workplaces is regulated by statute law in many countries.)

## Work Environment Requirements

The workplace environment should be designed and regulated as far as possible to ensure safety and freedom from health risks. This is often not possible for outdoor workplaces, or at least only possible to a limited extent. For indoor workplaces, basic workplace environment standards are established by legislation such as the **Workplace (Health, Safety and Welfare) Regulations 1992**:

- **Space** – provision of adequate space to allow workers to perform the task safely.
- **Seating** – provision of appropriate seating where work tasks allow. Seats should be stable with a backrest and footrest where appropriate.
- **Ventilation** – provision of a sufficient supply of fresh or purified air.
- **Heating** – maintenance of a reasonable temperature in indoor workplaces. Note that workers carrying out hard manual work will generate more metabolic heat than those doing sedentary work. A lower minimum workplace temperature can be comfortably tolerated by those doing manual labour. The **Approved Code of Practice (ACoP)** to the regulations sets a minimum indoor temperature of 16°C for sedentary (inactive or seated) work and 13°C for manual work.
- **Lighting** – provision of adequate lighting.

### TOPIC FOCUS

Factors to consider when providing workplace lighting:

- Minimum light levels (lux levels) should be achieved; these are indicated by codes of practice and guidance.
- Natural light should be used in preference to artificial light.
- Light levels should be adjusted to suit the level of detail required and the visual acuity of the workers.
- Local lighting, such as spotlights positioned above machinery, might be required to give higher levels of light on critical areas.
- Lighting must be arranged to avoid reflections and glare that might dazzle or temporarily disable.
- Lighting must be arranged to avoid the creation of shadows that might obscure areas and create risk.
- Flickering should be avoided to prevent nuisance and, in particular, the 'stroboscopic effect' (see the section on machinery lighting in Element 9).
- Lighting must be suitable for the environment (e.g. intrinsically safe lighting used in a flammable atmosphere).
- Emergency lighting should be provided to allow safety in the event of mains supply failure.

## Exposure to Extremes of Temperature

### Effects of Exposure

Extreme temperature environments can be found in some workplaces. For example, workers in a foundry or bakery will be exposed to a very hot, dry environment; workers at a cold storage warehouse will be exposed to a very cold environment. Those who work outdoors may be exposed to both extremes, depending on climate and season.

Health and safety effects of working in a **hot environment** are:

- **Dehydration** – water is lost as a result of sweating.
- **Muscle cramps** – a result of salt loss through sweating.
- **Heat stress** – core temperature (37°C) cannot be controlled and starts to increase causing discomfort, lethargy and fainting.
- **Heat exhaustion** – a precursor to heat stroke.
- **Heat stroke** – core temperature increases rapidly causing delirium, hallucinations, coma and death.
- **Other effects** associated with the source of the heat, such as skin burns or cancer from exposure to sunlight, or burns from radiant heat (see Element 10) and contact with hot surfaces.

Health and safety effects of working in a **cold environment** are:

- **Hypothermia** – core temperature drops below 35°C causing shivering, mood swings, irrational behaviour, lethargy, drowsiness, coma and death.
- **Frostbite** – body tissues freeze causing tissue damage and, in extreme cases, necrosis, gangrene and amputation.
- **Slip hazards** – in particular, floors becoming slippery with ice.
- **Freeze burn injuries** – from skin contact with very cold surfaces.

Apart from these specific effects, both environments create an increased risk of fatigue because of the stress on the body; this makes workers more prone to accidents and human error.

## Preventive Measures

Inevitably, the first course of action is to eliminate the need for workers to enter the extreme temperature environment (e.g. by automation of a process). Where this cannot be done, the environment might be regulated to reduce the temperature extremes (e.g. heating a cold workplace to more reasonable temperatures). If these options are not possible then other controls might be:

For a **hot environment**:

- Provide good workplace ventilation – such as air conditioning or fans to provide moving air (which has a cooling effect).
- Insulate heat sources by lagging hot pipes.
- Shield heat sources to control radiant heat and prevent contact burns.
- Provide cool refuges where workers can escape the heat.
- Provide easy access to drinking water or isotonic drinks (which replace salts lost through sweating).
- Provide frequent breaks and job rotation.
- Provide appropriate clothing that allows workers to sweat freely (consideration must be given to other workplace hazards).

For a **cold environment**:

- Prevent or protect workers from draughts.
- Shield/lag extremely cold surfaces.
- Provide warm refuges where workers can warm up.
- Provide PPE such as insulated jackets, trousers, boots, balaclavas, etc.

- Provide frequent breaks and job rotation.
- Provide easy access to hot food and drinks.
- Scrape, salt or grit icy floors.

### MORE...

Visit the following website for additional information on thermal comfort in the workplace:

[www.hse.gov.uk/temperature](http://www.hse.gov.uk/temperature)

In both types of environments information, instruction, training and supervision should be provided so that workers understand the health consequences of the environment and the early warning signs of problems. Workers might also be given the opportunity to acclimatise to the most extreme environments and may be subject to health surveillance.

### Legal Standards

For most workplaces:

- ILO C120 – Hygiene (Commerce and Offices), Convention, 1964 (No. 120).
- ILO R120 – Hygiene (Commerce and Offices), Recommendation, 1964 (No. 120).

For construction sites:

- ILO C167 – Safety and Health in Construction Convention, 1988 (No. 167).
- ILO R175 – Safety and Health in Construction Recommendation, 1988 (No. 175).

### STUDY QUESTIONS

1. Identify the six main welfare requirements in any workplace.
2. Identify the protective measures to be used for working in conditions of extreme heat.

(Suggested Answers are at the end.)

# Working at Height

## IN THIS SECTION...

- Work at height is work where there is a risk of a fall liable to cause personal injury unless precautions are taken.
- Work at height results in more fatalities than any other work activity.
- The main risks associated with work at height are falls and falling objects. These are created by hazards such as fragile roofs, sloping roofs, deteriorating materials, unprotected edges, unstable access equipment and adverse weather conditions.
- Work at height should be avoided where possible. Where this is not possible, engineering measures (e.g. edge protection) should be used to prevent falls. Where this cannot be done, measures should be taken to minimise the distance fallen and the consequences of the fall (e.g. using a safety net).
- Scaffolds must have a securely guarded work platform, be constructed of appropriate materials by competent people and be routinely inspected to ensure their ongoing safety.
- Mobile tower scaffolds, Mobile Elevating Work Platforms (MEWPs) and ladders each have their own set of hazards and precautions for safe use.

## Introduction to Working at Height

### DEFINITION

#### WORK AT HEIGHT

Work where there is a risk of a fall liable to cause personal injury unless precautions are taken.

Note that this definition is based on the one found in the UK **Work at Height Regulations 2005**.

Note also that the definition does not mention ground level, so it is possible to work at height while underground or at ground level (e.g. at the side of a sheer drop such as an excavation). Walking up and down staircases are not working at height as defined by the Regulations.

Many types of work can expose people to working at height, including:

- Steel workers erecting a steel framework of a building.
- Scaffolders erecting or striking (taking down) a scaffold.
- Roofers cladding the roof of a steel-framed building.
- Demolition workers using machinery in a multi-storey building.
- Welders working at the side of a deep excavation.
- Pipe fitters fixing pipework to the ceiling of a factory workshop.
- Painters working on the external walls of a building.

Some of these types of work will inherently involve work at height (e.g. scaffolding) and so those involved will be very used to this type of work. This can lead to complacency. Some of the other types of work, however, do not always involve work at height so those involved may lack competence.

The main risks associated with working at height are:

- The worker falling from height.
- An object falling onto people below.

Working at height causes a higher proportion of fatalities than any other types of work activity. Falls from height can result in:

- Death.
- Neck or spinal injury leading to permanent paralysis.
- Brain damage.
- Multiple broken bones.

**Falling objects** can also cause severe injuries that may result in the above.

## Risk Factors for Work at Height

There are several factors that influence the risks associated with work at height. Here are some of the main ones.

### Vertical Distance

The vertical distance is an obvious consideration in the potential risk of injury from work at height. However, although there is some truth in the expectation that the further a person falls, the greater the injury will be, a large number of fatalities actually occur as a result of falls from a height of just two metres or less, so it is not the only important consideration.

### Roofs

Roof work includes construction and maintenance such as replacing tiles, cleaning gutters and repairing chimneys. Many accidents occur during small jobs and maintenance work.

Particular dangers arise with two types of roofs:

- **Fragile Roofs**

Any roofing structure that is not specifically designed to carry loads and only has sufficient strength to withstand the forces produced by the weather should be considered a fragile roof. Roofing materials – such as cement, asbestos, glass, reinforced plastics and light tongue-and-groove wood covered with roofing felt – are all liable to collapse under the weight of a worker.

Fragile roofs should be clearly signed. The safe working method for fragile roofs is usually by the use of roof ladders or crawling boards. These are laid across the roof surface, supported by the underlying load-bearing roof members, and distribute the load of the worker over a wide area, enabling the roof structure to sustain the load safely.

- **Sloping (Pitched) Roofs**

These are roofs with a pitch greater than 10°. Falls from the edges of sloping roofs generally cause serious injury even when the eaves are low, as on a single-storey building. If the person has slipped down the roof from the ridge, considerable acceleration can be built up which tends to project the person from the eaves, adding to the force of impact with the ground and so to the seriousness of the injuries sustained.



Working on a sloping roof

## Deterioration of Materials

The condition of the structure on which people are working should be sound. However, materials deteriorate over time when exposed to the weather and attacked by insects, etc.

Unsound materials represent a hazard in two ways:

- The material breaking when a person puts their weight on it, causing a fall through the surface.
- The material breaking off and falling to hit people below.

It may not always be evident that deterioration has occurred until it is too late, so care must be taken to ensure that materials are sound and secure.

## Unprotected Edges

Where the edges of surfaces on which people are working are open, the risk of falls or falling objects is greatly increased. This applies to roofs, elevated walkways, scaffolding and access platforms, etc. The use of guardrails, fencing and protective boarding required to prevent such accidents will be discussed later.

Unprotected edges may exist at the edges of an area, such as a flat roof. They may also exist temporarily as a surface is worked on or created. For example, when a steel-framed building has sheets of roofing material added to form the roof, an unprotected edge is created at the edge of the roof sheets as they are added. This is normally referred to as a **leading edge**.

## Unstable or Poorly Maintained Access Equipment

Access equipment includes scaffolding, towers, platforms and ladders. There are in-built risks in using such equipment but they are compounded if the equipment is not properly stable and secured in some way.

Any access equipment that is incorrectly sited, poorly built or poorly secured will be inherently unstable and conditions such as overloading of the equipment, high winds or overreaching can then cause a catastrophic collapse or topple.

(See later for details on the ways in which access equipment can become unstable and the controls necessary for safe use.)

## Weather

The weather can increase the risks associated with working at height:

- Rain or freezing conditions can increase the risk of slipping.
- High winds can make access equipment unstable, blow loose materials off and, in extreme cases, blow workers off.
- Cold conditions cause loss of manual dexterity and can lead to increased risk of muscle injuries.

## Falling Materials

Objects falling from height are capable of causing considerable damage to both people and other materials that they hit. The objects themselves may be loose structural material, waste materials, or equipment or tools that are dropped.

Circumstances contributing to the likelihood of falling materials include:

- Deterioration of structures, causing crumbling brickwork or loose tiles.
- Unsafe storage of materials (e.g. at the edges of scaffold platforms or in unstable stacks).

- Poor housekeeping, leading to accumulation of waste and loose materials.
- Gaps in platform surfaces or between access platforms and walls.
- Open, unprotected edges.
- Incorrect methods of getting materials from ground level to the working area.
- Incorrect methods of getting materials down to ground level (e.g. throwing).

## Controlling the Risks of Work at Height

Work at height is regulated because of the very high risks associated with it. For example, in the UK, it is regulated by a specific set of regulations – **Work at Height Regulations 2005**. The Regulations apply a risk assessment-based approach to the management of working at height requiring that all this work be risk assessed.

### TOPIC FOCUS

The Regulations then impose a simple **risk prevention hierarchy**:

- **Avoid** work at height.
- Use work equipment or other measures to **prevent falls** where working at height cannot be avoided.
- Use work equipment or other measures to **minimise the distance and consequences** of a fall where the risk of a fall cannot be eliminated.

When applying the last two controls, **prioritise collective protection over personal protection**. In other words, choose control measures that will protect groups of workers rather than choosing PPE that only protects the one person who is using it and using it correctly. For example, a fall arrest safety net is preferable to fall arrest full-body safety harnesses and lanyards because the net protects all workers who may fall while working at height, whereas the fall arrest PPE only protects those workers who are wearing it if they have fitted and used it correctly (i.e. it is very reliant on personal behaviour).

The Regulations also require the provision of appropriate information, instruction and training to workers.

If fall arrest equipment is to be used, then procedures must be developed to allow for the speedy recovery of workers who fall into the fall arrest equipment.

## Avoiding Work at Height

The best way of managing the risks inherent in work at height is to eliminate the need to work at height entirely.

Avoiding the need for work at height can be achieved by:

- Good design (e.g. assembling guardrails or steelwork at ground level and then craning the steel and guardrails into place).
- Modifying the work process (e.g. cleaning windows from the ground by pole cleaning rather than off ladders).

In many instances, however, avoidance will not be possible and control measures for working at height will be required. The exact nature of the control measures should be decided during the risk assessment and will depend on various factors.

### TOPIC FOCUS

The factors to consider when identifying control measures for work at height are:

- Nature and duration of the task to be carried out.
- Level of competence of the persons to be involved.
- Training that may need to be provided.
- Planning and level of supervision required.
- Means of access and egress.
- Suitability of any equipment to be used, and its maintenance and pre-use inspection.
- The use of PPE, such as harnesses and helmets.
- Weather conditions.
- Health conditions of the individuals (e.g. vertigo or a heart condition).
- The need for a rescue plan and emergency procedures.
- Compliance with the regulations.

Finally, adequate supervision must be provided to ensure that the controls developed at the planning stage are implemented in practice.

## Preventing Falls and Falling Materials

**Proper planning and supervision of work** is important to prevent falls from height and falling materials. Those responsible for such work should be experienced and use their knowledge to ensure the:

- selection and use of correct access equipment;
- correct provision and handling of tools and materials (especially getting them up and down from work locations); and
- provision of adequate information, instruction and training of all persons who will be involved.

Regular inspection of the workplace, work equipment and work methods is essential to reduce the risks; this will include modifying or stopping work in adverse weather conditions. Unsafe acts should not be tolerated and must be stopped immediately, ensuring that all workers know why and the consequences if further unsafe work is carried out. Unsafe conditions should be corrected on the spot.

A simple hierarchy can be adopted to **prevent falls**:

- Provide a **safe working platform** with guardrails, fences, toe boards, etc. that are strong enough to prevent a fall.
- Where this is not possible or reasonable, provide properly installed personal **suspended access equipment**, such as rope access or boatswain's chairs (see later).
- If this is not possible, and a worker can approach an unprotected edge, provide **equipment which will arrest falls**, such as a full-body safety harness or safety net.



An independent tied scaffold with guardrails and toe boards; note the debris chute for safe disposal of rubble

This last option does not prevent falls but it does minimise the distance of the fall and the consequences (i.e. injury).

**Prevention of injury caused by falling materials** should be controlled using a similar approach:

- Prevent materials from falling using physical safeguards, such as toe boards and brick guards (see later).
- If risk remains, use physical safeguards to prevent falling objects from hitting people below such as debris netting, fans (wooden shielding angled to catch debris) and covered walkways.

## Guardrails and Toe Boards

Protection should be provided, wherever possible, at all unprotected edges to prevent people and materials from falling. This can be achieved by means of guardrails, toe boards and brick guards on scaffolding and other platforms.

**Guardrails** are designed to prevent people from falling, whereas toe boards and brick guards are principally designed to stop materials from falling.

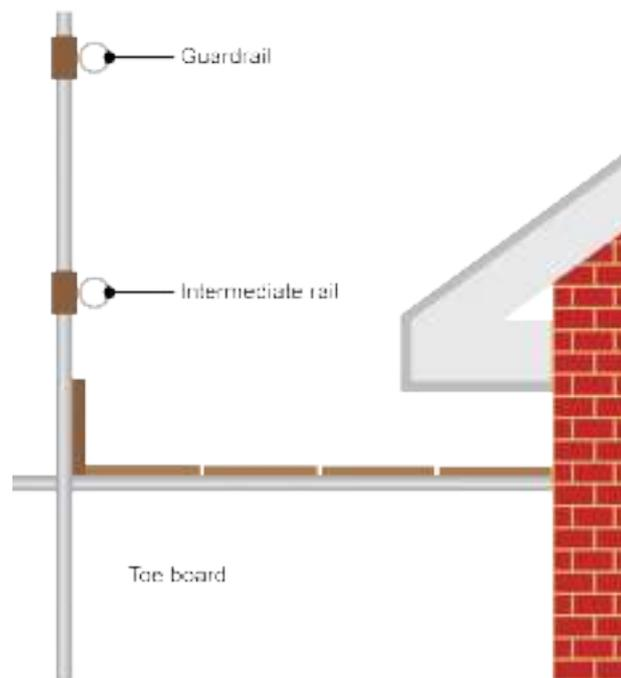

Guardrails on scaffold platform

**Key characteristics** of any guardrail should:

- Fully enclose all of the exposed unprotected edge.
- Be robust enough so that it will not bend or distort when fallen against (e.g. not a chain or rope).
- Be securely fixed in position so it will withstand any foreseeable impact.
- Be high enough to prevent a person from toppling over the top.
- Have no excessively large gaps in it so that a person could fall through.

**Toe boards** are usually scaffold boards laid on their edge at right angles (90°) to the working platform. They are laid at the outer edges and ends of the working platform, although sometimes the inner edge (the one nearest the building) also requires edge protection. Toe boards prevent small objects, such as rubble and tools, from being casually kicked off the platform.



Use of a brick guard

**Brick guards** prevent a more substantial amount of material from falling and have a secondary function of helping to prevent people from falling as well.

Guardrails, toe boards and brick guards can be applied to the edge of flat roofs, scaffolds, mobile tower scaffolds, MEWPs (such as cherry pickers) and access cradles (as used for window cleaning).

Any gaps in edge protection (e.g. to allow access by ladder) should be the minimum required for reasonable access.

## Work Platforms

Work platforms (e.g. on a scaffold) should be:

- Sufficiently large to allow safe use.
- Capable of bearing the loads imposed upon them.
- Fully boarded to prevent gaps that could present tripping hazards or allow materials or people to fall through.

The platform is usually made up of scaffold boards resting on the scaffold framework. The boards should be free from significant defects such as rotted timber, large cracks, split ends or large or many notches cut into the wood. Usually, boards should be supported across three support members. Boards should not have long overlaps beyond their supports (because of the possible 'see-saw' effect).

## Suspended Access Equipment

Suspended access equipment usually consists of a suspended cradle lowered into position from above. The cradle can be fully guarded in with guardrails and toe boards to provide a safe work platform.

In some instances, it is not practicable to use this sort of equipment, so it may be necessary to use personal suspended access equipment, such as a boatswain's chair.



Boatswain's chairs being used for painting

A boatswain's chair can be used for light, short-term work. The chair usually consists of a seat with a back, a suspension point and a means for carrying tools. The user should be attached to the chair by a harness to prevent falls. Control of descent is by the user, based on the same techniques as abseiling, although there should not be a single suspension point.

## Emergency Rescue

Emergency procedures need to be developed for reasonably foreseeable events where workers might become trapped while working at height (e.g. if they cannot climb back after falling in a full-body safety harness).

The method of rescue may well be simple, such as putting up a ladder to a net and allowing the fallen person to descend. In other circumstances, the use of other work equipment may need to be considered, such as MEWPs or proprietary rescue systems.

Whatever method is selected, there should be arrangements in place capable of rescuing a person, and employers must ensure that those involved are trained in the procedures and that the equipment required is available.

## Minimising Distance and Consequences of a Fall

### Fall Arrest

Fall arrest is needed if it is not possible to provide a safe work platform with guardrails and toe boards – or an alternative means of safe access (such as suspended access equipment) – and workers might fall from height. Fall arrest comes in two main forms:

- **Collective protection systems**, such as safety nets and air bags.
- **Personal protective systems**, such as a fall arrest full-body safety harness and lanyard.

Ideally, collective protection should be used because this will protect all workers, irrespective of whether they are using their PPE correctly or not. For example, safety nets might be suspended underneath the open steel frame of a roof while workers fix the roof cladding material into place. Nets must be properly installed and securely attached by competent riggers as close as possible below the roof, to minimise the distance fallen.

Personal fall arrest equipment usually consists of a full-body safety harness connected to one or two lanyards (or wire rope on an inertia reel). The lanyard is connected to an anchor point during use.

Personal fall arrest equipment should only be used by trained workers. Harnesses, lanyards and anchor points should be routinely inspected to ensure they are in safe working order.

## Provision of Equipment, Training and Instruction

Workers should be trained in order to work at height safely, but the exact content of training will depend on the nature of the work and the access methods or controls used.

As a minimum, workers should have an awareness of the hazards, such as the possible presence of fragile roofing materials, unprotected edges, etc. Additional training may be required by law for the use of some equipment. For example, those erecting or modifying scaffolding should be competent, and those driving or using MEWPs should have attended a recognised operator training course.



A worker using fall arrest equipment; note the full-body safety harness with lanyard attached at the back

## Safe Working Practices for Access Equipment

### Ladders

Ladders are really only suitable for short-duration work. When climbing, the worker should maintain three points of contact (one hand and two feet, or two hands and one foot) and also try to maintain two feet and one hand on the ladder whenever possible at the work positions (e.g. inspection work or painting).

They are also suitable as a means of access and egress and are commonly used for access into excavations and onto scaffolds.

The main risks associated with using ladders include:

- Workers falling from a height:
  - Falling off the ladder.
  - The ladder toppling sideways.
  - The ladder base slipping out from the wall.
- Objects falling from height.
- Contact with live overheads.

Safety precautions for using ladders include the following:

- Not sitting or handling near live overheads.
- Sitting on a solid, flat base so that the feet do not sink into the ground. Weight should only be supported on the stiles – never on the rungs.
- Angling the ladder ideally at 75° to the horizontal or at a ratio of 1:4 (1 'out' to 4 'up') distance away from the wall to height.
- Resting the top of the ladder against a solid support.
- Ideally, securing the ladder at the top.
- If this is not possible, then attaching guy ropes and securing them to firm supports.
- If this is not possible, ensuring that the ladder is 'footed' by someone standing on the bottom rung.
- Extending the top of the ladder far enough above the level of the working position or the platform onto which it provides access to provide a safe handhold. This should be at least one metre or five rungs if used as a means of access. The stepping-off point should be safe and clear.
- Making sure that only one person climbs on the ladder at any one time.
- Not carrying anything in the hands while climbing, so that both hands are free to grasp the stiles.
- Maintaining three points of contact while working.
- Not painting wooden ladders as this can hide defects such as rot.

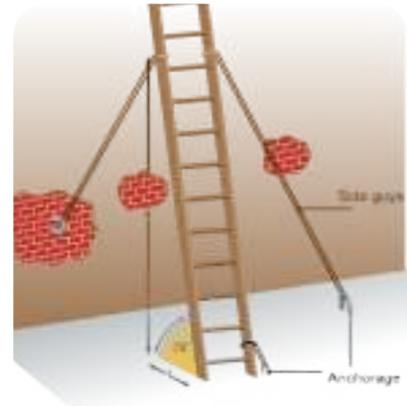

Various ways of anchoring a ladder



Ladder used to gain access to a scaffold platform; note how the ladder extends well above the stepping off point and how it has been secured to the scaffold

## Stepladders

Like ladders, stepladders are intended for short-duration, light work.

Safety precautions for the use of stepladders are:

- Carry out a daily check of the stepladder before use.
- Always ensure that the ladder is fully open.
- Make sure that the locking devices are in place.
- Only use on firm, level ground which is not slippery.
- Do not work off the top two steps (or the top three steps for swing-back/double-sided stepladders) unless there is a safe handhold on the steps.
- Avoid overreaching.
- Avoid side-on working.



Correct use of a stepladder

## Trestles and Staging Boards

Trestles are used with boards to provide a working platform. Trestles should be:

- Big enough to allow safe passage and safe use of equipment and materials.
- Free from trip hazards or gaps through which persons or materials could fall.
- Fitted with toe boards and handrails. If these are not fitted, the risk assessment would need to show that installing a guardrail had been considered and the reasons why it was not considered necessary.
- Kept clean and tidy, e.g. no accumulation of mortar and debris on platforms.
- Not loaded in a way to risk collapse or deformation that could affect their safe use (particularly relevant in relation to blockwork loaded on trestles).
- Erected on firm, level ground to ensure stability during use.

## Independent Tied Scaffolds

Scaffolding is made up of the following basic components:

- **Standards** – uprights or vertical tubes used to support the load to the ground.
- **Ledgers** – horizontal tubes tying the structure together longitudinally, usually running parallel to the face of the building.
- **Transoms** – short, horizontal tubes spanning across ledgers normally at right angles (90°) to the face of the building. They may also be used to support a working platform.
- **Bracing** – diagonal tubes that give the structure its rigidity.
- **Base plates** – small, square metal plates that the standards (uprights) rest on to prevent them sinking into the ground.
- **Sole boards** – large pieces of timber put under the base plates to spread the load over a wide surface area when the scaffold is erected on soft ground.
- **Work platform** – fully boarded.

- **Guardrails** – fixed to the standards (uprights) to fully enclose the work platform.
- **Toe boards** – fixed to the standards (uprights) to provide a lip to the work platform.

An independent tied scaffold is designed to carry its own weight and the full load of all materials and workers on the platform. It must be tied to the building where it is sited, to give stability and prevent movement.

As the total weight of the structure is supported by the ground, it is very important that the ground conditions are suitable to cope with the load. Base plates and sole boards may be used to spread the weight over a large surface area.

There are a number of ways in which the scaffold can be tied to the building to prevent movement:

- **Anchor bolts** – one end of a metal bolt is screwed into the wall of the building and the other end is attached to the scaffold tubing. These must be used with other types of tie and are tested for strength.
- **Through ties** – a scaffold tube is extended into the building through an opening (such as a doorway or window frame). The end of the tube inside the building is coupled to another tube bridging across the opening.
- **Reveal ties** – a scaffold tube is coupled to a reveal pin that is wedged tightly across an opening, such as a window reveal.
- **Rakers** – these are supports that push the scaffold onto the building. This system takes up space and may not be suitable in urban environments.

**Bracing** is another important component of the scaffold and is used to stiffen the scaffold framework to prevent collapse. Bracing consists of tubes running diagonally through the structure. These tubes may run perpendicular or parallel to the building facade.

**Key hazards** associated with using scaffolds include:

- Workers falling from the work platform.
- Objects falling from the platform.
- The structure collapsing.

Scaffolds should be erected by trained workers and inspected by a competent person.

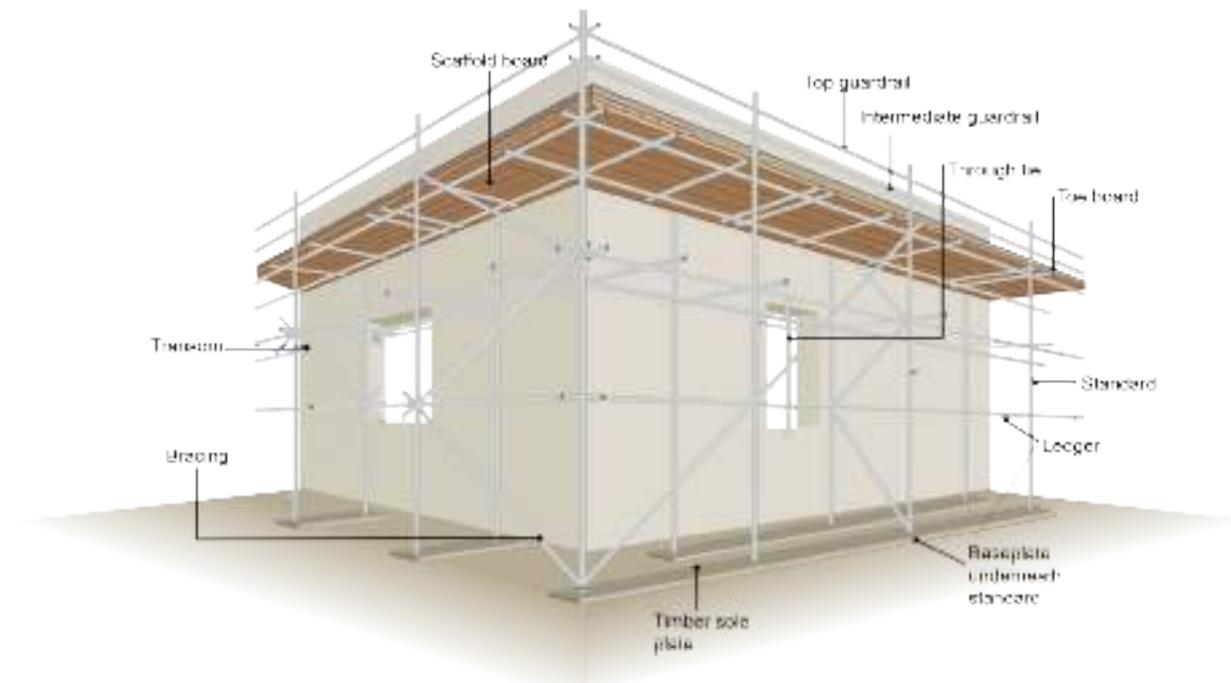

Independent tied scaffold

### TOPIC FOCUS

Factors that might cause the collapse of an independent tied scaffold are:

- Work platform overloaded.
- Scaffold built on soft ground without use of adequate sole boards.
- Scaffold not tied adequately to the building.
- Insufficient bracing incorporated into the scaffold.
- Standards not upright.
- Standards bent, buckled or heavily corroded.
- High winds.
- Incorrect couplers used to join tubes together.
- Scaffold struck by mobile plant.
- Scaffold erected by incompetent workers.
- Scaffold not inspected prior to use.

## Mobile Tower Scaffolds

Mobile tower scaffolds are often used for painting and maintenance jobs, both inside and outside buildings.

They are light-duty scaffolds and their use should be restricted to light work. They have a working platform at the top which is accessible by a ladder fitted internally. They can be constructed using normal scaffolding tubes but are mostly proprietary-made modular structures. The whole structure is usually mounted on wheels so that it can be moved about.

Since tower scaffolds are inherently unstable, they can only be built to a certain maximum height. This height depends on the size of the base – the larger the base, the higher the tower can go, and to enlarge the base it is usual to use outriggers. The maximum height will be determined by the 'base-to-height ratio' which is set by the manufacturer.

The tower can also be made more stable by attaching guys or using ballast.

The main **risks** associated with mobile tower scaffolds include:

- Workers falling from the work platform.
- Objects falling from the platform.
- The structure collapsing.
- The structure overturning (toppling).
- The wheels moving unintentionally.
- Contact with live overheads.



A worker enters the working platform of a mobile tower platform through an internal trapdoor; note the ladder built into the side of the frame and also the rakers or outriggers

## TOPIC FOCUS

Safety precautions for safe use of mobile tower scaffolds include the following:

- The guardrail must be fitted to the work platform.
- The tower must not be overloaded.
- The wheels should be locked when the tower is in use.
- The tower must be sited on firm, level ground.
- People and materials should not remain on the tower when it is moved.
- Care should be taken to avoid overheads when the tower is moved.
- Outriggers should be used where necessary to ensure stability.
- People should not climb up the outside of the tower.
- The tower must be built by trained workers (e.g. Prefabricated Access Suppliers' and Manufacturers' Association (PASMA)).
- The tower must not exceed the relevant base-to-height ratio.
- The tower must be inspected prior to use and routinely during use (e.g. at the start of every shift and after any event which might affect its strength and stability).

## Mobile Elevating Work Platforms

Mobile Elevating Work Platforms (MEWPs) are motorised vehicles or trailers with powered extending arms or lifting mechanisms supporting a work cradle. There are many different types of MEWPs such as scissor lifts and cherry pickers.

**Risks** associated with using MEWPs include:

- Workers falling from the work cradle/platform.
- Objects falling from the cradle/platform.
- The MEWP collapsing.
- The MEWP overturning (toppling).
- Contact with live overheads.
- The cradle/platform becoming trapped against adjacent structures.
- The MEWP shearing against adjacent structures.
- Unauthorised use.



A cherry picker

### TOPIC FOCUS

Safety precautions for use of MEWPs include the following:

- The vehicle should be sited on firm, stable ground.
- There should be sufficient clearance from obstructions and overheads when operating.
- Barriers should be around the MEWP to prevent it being struck by vehicles or mobile plants.
- Barriers should keep people out from underneath the cradle/platform.
- Guardrails should be incorporated into the cradle/platform and must not be removed.
- Full-body safety harnesses and lanyards should usually be worn and attached to an anchor point in the cradle (subject to risk assessment).
- They should not be driven with the cradle raised unless specifically designed to do so.
- They must not be overloaded.
- They must be inspected and maintained as an item of lifting equipment designed to carry people. This will include statutory examination which would usually be carried out every six months.
- Use must be restricted to trained, authorised staff (e.g. International Powered Access Federation (IPAF) certificated operator).



Steel workers using MEWPs to access structural steel that is being lifted into place; note the use of full-body safety harnesses despite being in enclosed cradles

## Leading Edge Protection

Leading edges are unprotected edges that are created and move as work progresses. Typical leading edges are created when sheet materials are added to a steel-framed building to clad the roof of the building.

Precautions must be taken to prevent falls from these leading edges.

Nets, staging or soft landing systems (such as bags filled with polystyrene balls) placed immediately below the leading edge are the preferred options in this instance. However, where these are not reasonably practicable, consideration must be given to using work restraint full-body safety harnesses with running line systems or temporary barriers at the leading edge.

Safety netting is the preferred method of fall protection as it provides collective protection and does not rely on personal behaviour to ensure safety. Nets protect every person working at height who might fall from the leading edge.

If safety nets are used, they must be:

- installed as close as possible beneath the roof surface;
- securely attached and able to withstand a person falling onto them; and
- installed and maintained by competent personnel.

Harnesses and running line systems involve installing an anchor line or wire that allows workers to move forward with the leading edge as work progresses. If harnesses and running line systems are used, they must be:

- securely attached to an adequate anchorage point;
- appropriate for the user and in good condition;
- properly used ensuring this requires tight discipline; and
- compatible.

## Inspection of Access Equipment

It is good management practice (and usually a legal requirement) to inspect scaffolds routinely. Scaffolds should be inspected:

- When they are first erected.
- After any substantial alteration.
- After any event that may affect their stability (e.g. after being struck by a vehicle or after high winds).
- Periodically (typically weekly).

Points to check would include:

- Condition of the tubes (especially standards).
- Tying and bracing.
- Condition of the work platform.
- Edge protection (guardrails, toe boards).
- Ground conditions (use of base plates and sole boards).
- Safe access.
- Safe working load.

Details of these inspections should be carefully recorded. The check is usually indicated by the use of a green tag to confirm that it has passed the inspection. It is particularly important that any defects noted are acted upon.

Other work equipment used for work at height should also be inspected (e.g. MEWPs, ladders, mobile tower scaffolds, full-body safety harnesses, lanyards, anchor points and safety nets).

## Prevention of Falling Materials Through Safe Stacking and Storage

Workplaces can easily become very untidy if housekeeping is not managed. Spoil heaps at excavations, piles of new materials, debris and waste can all accumulate very quickly. This can hinder or even prevent the safe movement of pedestrians and vehicles around the workplace, and can block light and access to essential services, such as fire equipment. In some instances, stacks and piles of materials can present an immediate danger of collapse, and stacked materials in particular can topple over if not stacked correctly.

Good housekeeping starts with good design and layout of the workplace; sufficient space must be allocated for the **storage of materials** at the planning stage:

- Storage areas should be clearly defined.
- Separate areas should be used for different items (for ease of identification).
- Certain materials and substances should be segregated during storage, or purpose-built secure storage may be required (e.g. gas bottle cages).

- Areas should be kept clean and tidy and routinely inspected.
- Appropriate warning signs should be displayed where necessary (e.g. flammable materials).
- Storage areas should not be used for work activities.

**Stacking materials** is an effective way to utilise space.

When stacking:

- Each stack should be for one material only, not mixed.
- A maximum stack height must be set (dependent on strength and stability of the material being stacked).
- Stack should be vertical (not leaning).
- Pallets should be used to keep materials off the ground.
- Sufficient space must be allowed between stacks for safe movement.
- Stacks must be protected from being struck by vehicles.

### MORE...

Find out what you need to know about work at height here:

[www.hse.gov.uk/work-at-height](http://www.hse.gov.uk/work-at-height)

## Legal Standards

For most workplaces:

- ILO C155 – Occupational Safety and Health Convention, 1981 (No. 155).
- ILO R164 – Occupational Safety and Health Recommendation, 1981 (No. 164).

For construction sites:

- ILO C167 – Safety and Health in Construction Convention, 1988 (No. 167).
- ILO R175 – Safety and Health in Construction Recommendation, 1988 (No. 175).

### STUDY QUESTIONS

3. Outline the safe method of working on a fragile roof.
4. Identify the main risks of using ladders.
5. Identify the measures that should be taken to prevent materials falling from a height.
6. In respect of scaffolding:
  - (a) What is the difference between standards, ledgers and transoms?
  - (b) What is the difference between tying and bracing?
7. State the safety precautions that need to be taken when using MEWPs.
8. Identify the angle at which ladders should be positioned.
9. Identify when scaffolding should be formally inspected.

(Suggested Answers are at the end.)

## Working in Confined Spaces

### IN THIS SECTION...

- A confined space is any place which has an enclosed nature and a risk of fire or explosion; loss of consciousness or asphyxiation arising from gas, fumes, vapour or lack of oxygen; drowning; asphyxiation as a result of entrapment in free-flowing solid; or loss of consciousness as a result of increased body temperature.
- Before entry into a confined space takes place, a risk assessment must be carried out by a competent person to consider the hazards created by the condition of the space itself, the work activities to be carried out and those outside the space.
- All entry into confined spaces must be done under a comprehensive safe system of work that will usually include the use of a permit-to-work system and provision for emergency rescue and first aid.

### Introduction to Confined Spaces

A confined space is defined in the GB **Confined Spaces Regulations 1997** as:

*"any place, including any chamber, tank, vat, silo, pit, trench, pipe, sewer, flue, well or other similar space in which, by virtue of its enclosed nature, there arises a reasonably foreseeable specified risk."*

These 'specified risks' include:

- Fire or explosion.
- Loss of consciousness or asphyxiation arising from gas, fumes, vapour or lack of oxygen.
- Drowning.
- Asphyxiation as a result of entrapment in free-flowing solid.
- Loss of consciousness as a result of increased body temperature.

Note that a confined space has two characteristics:

- An **enclosed nature** (ventilation will be restricted and access/egress may be difficult).
- One or more of the **foreseeable specified risks** exist.

Note that a confined space does not have to be small; an empty oil storage tank can be big enough to play a game of football inside, but it is still a confined space because of its enclosed nature and its risk of fire, asphyxia and drowning (as a result of an inflow of oil or other liquid while people are working in the tank, e.g. an in-feed pump might be accidentally switched on).

The hazards associated with working in confined spaces are defined by the nature of the confined space itself and also by the nature of the work activity that is to take place.

For example, welding work carried out inside an empty petrol storage tank is working inside a confined space and petrol residue left inside the tank would be a significant hazard. It would create an obvious fire and explosion risk and also a risk of loss of consciousness as a result of petrol vapour inhalation. These are risks inherent in the storage tank as a result of the presence of the petrol residue. However, welding work also has hazards and risks associated with it, and these may be exaggerated by the fact that the work activity is taking place inside a metal tank. Any form of arc welding involves electricity



Entry into a sewer – confined space entry

and so the risk of electric shock and burns is created. Welding generates fumes, creating a risk of inhalation of a hazardous substance. It also generates heat, creating a risk of heat stress, and it uses up oxygen, creating a risk of loss of consciousness and asphyxiation as a result.

Because of the risks inherent with entry into confined spaces, when accidents occur they often result in multiple fatalities. This is sometimes because several workers are inside the confined space and are overcome by the hazard at the same time. However, it can also be the case that, when a single worker is overcome by the hazard inside the confined space, other people will attempt to rescue them and will then be overcome.

## Factors to be Assessed

### General Condition of the Confined Space

The general condition of the confined space will need to be considered, such as:

- **Previous contents** – such as powders, liquids or gases that have previously been in the space which will give an indication of possible hazards.
- **Residues** – such as sludge or scale that may release gas/vapour when disturbed.
- **Contamination** – substances that may leak into the space from adjacent areas. For example, methane gas can leak out of the ground into a deep excavation.
- **Oxygen deficiency and oxygen enrichment** – low oxygen concentrations that impair mental functioning significantly and can lead to loss of consciousness and asphyxia. Increased oxygen concentration greatly increases fire risk.
- **Physical dimensions** – that may have an impact on where residues and gas/vapour may be present and will affect ventilation methods.

### Hazards Arising from the Work

Hazards associated with the work activities and work equipment to be used inside or adjacent to the space are:

- **Cleaning chemicals** – chemicals used for cleaning could affect the atmosphere directly or interact with residual substances present in the confined space.
- **Sources of ignition** – welding could act as an ignition source for gases and vapours inside the space. Tools and equipment such as lighting may need to be ATEX rated (i.e. rated for use in an explosive atmosphere; see Element 10) so that they do not present a source of ignition.
- **Increasing temperature** – hot work and strenuous work activities can have an effect on the thermal comfort of workers, particularly when PPE is being worn. This may lead to heat stress and heat stroke.

### Hazards from Outside the Space

It is also essential to assess the need to isolate the confined space to prevent dangers arising from outside such as the **ingress of substances**. This is when there may be a risk of substances (e.g. raw materials) from nearby processes and services entering the confined space caused, for example, by the inadvertent operation of machinery. **Emergency rescue** should be anticipated and appropriate rescue arrangements made. The likely risks, and therefore the equipment and measures needed for a rescue, must be identified and the equipment made available for use.

## Safe System of Work for Entry

### TOPIC FOCUS

Since work in confined spaces is a high-risk activity, there are some general principles that should always be applied:

- Do not work inside a confined space if it is possible to do the work in some other way.
- If confined space entry is the only way to do the work, then a competent person must carry out a risk assessment.
- A safe system of work must be developed for the confined space entry.
- Emergency arrangements must be put in place as part of that safe system of work.
- Confined space entry must be under permit-to-work control.
- All personnel must be trained.

When developing the safe system of work for confined space entry, the competent person will have to decide on the appropriate:

- Level of supervision.
- Competency requirements of the people doing the work.
- Communication methods to be used inside the confined space.
- Atmospheric testing and monitoring before and during entry.
- Ventilation that may be required before and during entry.
- Removal of residues.
- Isolation and lock-off of in-feeds and out-feeds.
- Isolation and lock-off of electrical and mechanical hazards.
- PPE requirements for workers inside the confined space which may include respiratory protective equipment.
- Safe and quick access and egress methods.
- Fire prevention measures.
- Lighting that is suitable and safe to use in the atmosphere inside the confined space.
- Suitability of individuals in terms of body size and psychology (e.g. not claustrophobic).
- Emergency and rescue arrangements to cope with foreseeable emergencies.

## Permit to Work

A permit-to-work system should be used to control almost all entry into confined spaces.

### TOPIC FOCUS

The general details to be included in a permit to work reflect the operation of the permit system and can be summarised as:

#### Issue

- Description of the work to be carried out (details of plant and location).
- The date and time of issue and the duration over which the permit will be open (remain valid).
- Assessment of hazards associated with the job.
- Controls required, such as isolations, PPE and emergency procedures.
- Signature of the authorised person issuing the permit.

#### Receipt

- Signature of the workers accepting the permit.

#### Clearance

- Signature of the workers/supervisor stating that the space has been made safe (e.g. work completed) and that they have left the confined space and isolations, etc. can be removed.

#### Cancellation

- Signature of the authorised person stating that the isolations have been removed, the confined space has been accepted back and that its use can be restarted.

Each permit will have a unique identification number so that copies can be traced back to their specific source.

A permit-to-work system would not necessarily be required where:

- the assessed risks can be controlled easily; and
- the system of work is very simple; and
- other work activities being carried out cannot affect safe working in the confined space.

### MORE...

Further information on confined spaces can be found at:

[www.hse.gov.uk/confinedspace](http://www.hse.gov.uk/confinedspace)

[www.hse.gov.uk/pubns/indg258.pdf](http://www.hse.gov.uk/pubns/indg258.pdf)

### Legal Standards

For most workplaces:

- ILO C155 – Occupational Safety and Health Convention, 1981 (No. 155).
- ILO R164 – Occupational Safety and Health Recommendation, 1981 (No. 164).

For construction sites:

- ILO C167 – Safety and Health in Construction Convention, 1988 (No. 167).
- ILO R175 – Safety and Health in Construction Recommendation, 1988 (No. 175).

### STUDY QUESTIONS

10. Identify the meaning of the phrase 'confined space'.
11. Identify the various issues that must be addressed in a safe system of work for entry into a confined space.  
(Suggested Answers are at the end.)

# Lone Working

## IN THIS SECTION...

- Lone workers can be defined as workers who are separated from their work colleagues.
- Lone working activities must be risk assessed and the risk eliminated or controlled by the use of a safe system of work.
- Key issues for the safe system of work are adequate levels of training, supervision and monitoring.

## Introduction to Lone Working

Lone workers can be defined as workers who are separated from their work colleagues.

People who work entirely on their own for periods of time, or those who are not alone but are not with colleagues whom they can rely on for help, can be classified as lone workers.

Note that a lone worker may not, in fact, be alone; they may be surrounded by people – such as members of the public or customers – but those people are not their work colleagues.

Many people carry out their work in this way, perhaps all the time or on a regular or occasional basis (e.g. sales representatives; installation, repair and maintenance staff; cleaners; night security workers, etc.).

For example, a service engineer who spends four hours alone in a plant room servicing machinery is a lone worker. So is a healthcare worker who travels around in the local community visiting elderly patients to provide care (even though they may be in sight of other people at all times during their working day).

Lone workers are a group of workers who are especially vulnerable in certain instances:

- They may be more at risk of violence, particularly if the worker is exposed to members of the public, has to travel out into the community or is involved in work that brings them into contact with violent people (e.g. prison staff or mental health nurses).
- They may be more at risk if they are injured or fall ill. Certain types of work involve a high risk of personal injury or ill health (e.g. confined space entry). In these situations, lone working may be inappropriate or additional precautions may be necessary to protect the individual.

## Risk Assessment Factors for Lone Working

The hazards that a lone worker may encounter will be the same as those of their colleagues working together, but the risks may be higher because:

- They lack assistance to do the work.
- They lack immediate assistance if things go wrong.
- Communication with colleagues and management is more difficult.

Therefore lone working must be carefully risk assessed. A range of factors must be considered in this risk assessment. These include the risk inherent in the work such as the:

- Handling or use of equipment that one person would have difficulty handling or using alone (e.g. safe handling and use of ladders).
- Safe access and egress to the workplace (e.g. the potential for getting locked into a secured workplace).



A worker in a remote location uses a working radio to ensure good communication

- Use of machinery that one person cannot operate safely (e.g. reversing vehicles in a heavily congested pedestrianised area).
- Handling or use of hazardous chemicals (e.g. concentrated acids or alkalis).
- Risk of violence and/or aggression (e.g. home visits with potentially violent people).

They also include issues related to the individual worker such as:

- Any medical conditions that may create issues during the normal course of work or in the event of an emergency.
- The vulnerability of the worker because of a personal characteristic (e.g. young trainee).
- Any language barriers that may present an issue in the event of an emergency.

## Safe System of Work for Lone Working

A typical lone working scenario is a worker travelling away from their normal place of work, perhaps to undertake some work at a remote site, or to visit a customer or client. In this situation, the controls outlined in the Topic Focus box below can all be applied through the risk assessment process.

### TOPIC FOCUS

To manage the risks associated with lone working, a risk assessment must be carried out and a safe system of work developed.

Various control measures may have to be implemented in the safe system of work:

- No lone working for certain high-risk activities (such as confined space entry).
- Arrangements for remote supervision.
- Procedures for logging workers' locations when lone working.
- The use of mobile phones or radios to ensure good communication.
- Lone worker alarm systems to raise the alarm and pinpoint the worker.
- Procedures to be adopted by workers when lone working.
- Emergency procedures.
- Training for workers in these procedures.

The key principles are:

- Lone workers must receive an appropriate level of **training** so that they understand:
  - the job;
  - the specific control measures associated with the lone working nature of the job; and
  - any additional precautions or restrictions that may apply and the emergency procedures.
- An appropriate level of **supervision** must be provided. This might be done remotely – by phone or radio – or by accompanying workers early in their work experience. The higher the risk associated with the work, the greater the need for supervision. The lower the level of competence of the worker, the greater the need for supervision.
- A **monitoring** system must be in operation so that routine communication can be achieved and incidents or emergencies can be dealt with effectively. In some instances, this will mean routine supervisory oversight. In other cases, mobile phone or lone worker technology can be used to raise the alarm to trigger an emergency response.

**MORE...**

Further information on lone working can be found at:

[www.hse.gov.uk/pubns/indg73.pdf](http://www.hse.gov.uk/pubns/indg73.pdf)

[www.suzylamplugh.org](http://www.suzylamplugh.org)

**Legal Standards**

- ILO C155 – Occupational Safety and Health Convention, 1981 (No. 155).
- ILO R164 – Occupational Safety and Health Recommendation, 1981 (No. 164).

**STUDY QUESTIONS**

12. Identify the meaning of the term 'lone worker'.
13. Identify four control measures that might be used to reduce the risk associated with a lone working activity.

(Suggested Answers are at the end.)

## Slips and Trips

### IN THIS SECTION...

- Pedestrians are exposed to the risk of slips and trips while moving around in workplaces. Common causes include slippery surfaces, uneven surfaces and trailing cables.
- The risk can be controlled through the risk assessment process and by careful design, construction and operation of the workplace.
- Some key controls are:
  - Use of non-slip surfaces.
  - Spill control and good drainage.
  - Using signs and PPE.
  - Good housekeeping.
  - Information, instruction, training and supervision.

### Common Slipping and Tripping Hazards

When people move around in workplaces, they are exposed to a range of hazards simply by being pedestrians. One of the most significant risks is that of slipping and tripping.

When people slip or trip, they often (although not always) fall to the floor. Though falls on the same level do not always lead to serious injury, they may well lead to broken bones (especially in the hand, wrist or arm).

Steps and stairs are places of particular concern because they are locations where slip, trip and fall accidents can occur more frequently and the consequences of such accidents can be more serious.

Slips and trips (and falls on the same level, i.e. not falls from height) are the biggest single cause of non-fatal injury to workers reported to authorities each year with the most common type of injury being broken bones.

Typical **slip** hazards include floor surfaces that are:

- Smooth and inherently slippery (e.g. polished marble).
- Wet because of rain, spills or cleaning operations.
- Contaminated with a slippery substance (e.g. fat or leaves).
- Covered with frost or ice (e.g. outside pavements in winter or the floor in a freezer).

Note that a person's footwear can make a big difference to how vulnerable they are to slipping on a floor. Unsuitable footwear is, therefore, a significant risk factor in some slip and trip accidents.

Typical **trip** hazards include:

- Uneven or loose floor surfaces (e.g. broken paving slabs or a poorly laid floor mat).
- Trailing cables (e.g. the flex of a vacuum cleaner).
- Objects on the floor (e.g. a bag left on the floor adjacent to a walkway).



Slips, trips and falls on stairs often cause serious injury

Note that people also frequently ‘trip over their own feet’. This can happen even when there are no hazards present, the floor condition is fault-free and there is nothing wrong with the individual’s footwear.

## Control Measures for Slips and Trips

The control strategies for managing the risk inherent in the movement of people in a workplace are based on basic health and safety management principles:

- Eliminate the hazard.
- Create a safe place.
- Create a safe person.

The starting point is risk assessment.

### Risk Assessment

A risk assessment covering the safe movement of pedestrians in a workplace should:

- Identify the various hazards that present risk to pedestrians (as indicated above).
- Identify the groups at risk (workers, members of the public, etc.) and those who might be especially vulnerable (young children, the elderly, people with certain disabilities such as visual impairment, etc.).
- Evaluate the risk by considering the existing controls, the adequacy of those controls and any further controls required to reduce the risks to an acceptable level.
- Be recorded and implemented.
- Be subject to review as the workplace changes, in response to incidents and perhaps periodically.

During this risk assessment, it is important to consider the:

- Normal patterns of movement in and around the workplace.
- Predictable abnormal movements (such as taking shortcuts and fire evacuations).
- Accident history of the workplace that might indicate problem areas.
- Impact of adverse weather conditions (such as freezing conditions, wind and rain).
- Maintenance requirements of the various controls (e.g. floor surface cleaning and repair needs).

### Slip-Resistant Surfaces

All floor surfaces where people may walk should be designed to ensure an appropriate level of slip resistance. If this is not done during construction, then slip-resistant surfaces may have to be fitted or applied at a later stage (e.g. by applying a non-slip resin to an existing floor).

Several factors will affect the kind of slip resistance that is required, such as:

- The number of people who walk on the floor.
- The footwear those people might be wearing.
- The wear and tear that the surface will be subject to (e.g. vehicle traffic).
- Foreseeable spills and contamination on the floor (e.g. chemicals).
- Environmental conditions, such as weather, temperature or sunlight.

## Spillage Control and Drainage

Floors and pedestrian routes should be designed and constructed to withstand foreseeable spillages. Such spillages might simply be water (e.g. drinks) but in other instances might be oil, fuels (e.g. diesel), solvents or corrosive chemicals (e.g. sodium hydroxide).

Spills must be controlled to prevent slip hazards and degradation of the floor surface itself, which can lead to potholes and trip hazards.

Spill control is best achieved by preventing the spill from happening in the first place. This might be done by implementing:

- maintenance and inspection (e.g. of pipelines, valves or taps); or
- behavioural controls (e.g. banning drinks from an area).

If spills cannot be prevented, then measures can be taken to prevent them from contaminating walkways and floors (e.g. drip trays under leaking oil sumps and bunds around storage tanks).

### DEFINITION

#### BUND

A wall built around a storage tank or drum compound which is intended to contain any leaks or spills.

Where a floor or pedestrian route is likely to get wet, adequate drainage should be provided, since:

- Outdoor walkways may be subject to rainfall.
- Indoor walkways may be subject to frequent wetting during normal use (e.g. shower rooms and changing facilities) or cleaning operations (e.g. in a food production factory).

## Use of Signs and Personal Protective Equipment

Clearly visible and easily understood signs and markings should be provided so that pedestrians (even those unfamiliar with the workplace) are made aware of hazards and what they must do to avoid them.

Signs should conform to relevant standards. Typical signs might include prohibition signs (e.g. 'No unauthorised access') and warning signs (e.g. 'Caution wet floor').

Specific footwear may be necessary to protect pedestrians from the risk of slips and trips as they move about the workplace. This would usually be shoes or boots with a non-slip tread on the sole that has been specifically selected by the employer to provide good slip resistance on the floor surfaces encountered at work. Boots may also be selected with a higher ankle cuff to give protection to the ankle in the event of tripping or stumbling. Even if specific footwear is not specified and provided, it may be necessary to prohibit the use of certain types of footwear in the workplace such as high-heeled shoes in a catering kitchen.



No unauthorised access sign

## Information, Instruction, Training and Supervision

Safe movement of people in the workplace inevitably requires giving people information, instruction and training so that they understand what is expected of them and how they can apply it. In some instances, this can be done with the use of appropriate signs; in others, it requires the provision of specific training to communicate safety rules. Worker induction training should incorporate information about safe movement around the workplace. This should also be provided to contractors working on site and may also be necessary for visitors.

Since people do not always follow the instructions and training that they are given, there should be an adequate level of supervision. This usually means simply enforcing the rules that have been developed about housekeeping, safe use of walkways, etc.

## Housekeeping and Maintenance of a Safe Workplace

Once measures have been taken to ensure that pedestrians can move around the workplace safely, some thought must be given to the maintenance of that safe workplace.

### TOPIC FOCUS

Various maintenance issues might be considered:

- Floors and walkways should be cleaned routinely to ensure that surfaces are kept free of contamination.
- Spills should be cleaned up quickly and safely.
- Housekeeping routines should be established to ensure that pedestrian routes are free of trip hazards and obstructions.
- Floors and walkways should be inspected and repaired to keep them in a safe condition (e.g. potholes should be repaired as soon as possible).
- Access and egress routes should be inspected routinely and cleaned or repaired as necessary. This is particularly important for outdoor areas where snow and ice can make external pedestrian walkways hazardous (in which case, gritting or clearing the snow and ice may be appropriate).
- Emergency exit routes should be kept free of slip and trip hazards and obstructions at all times.
- Lighting is essential for safe movement through a workplace and lights should therefore be routinely inspected and replaced/repared as necessary.

The frequency of cleaning and inspection and the timescales for repairs will depend on the nature of the workplace. For example, in an engineering workshop where swarf and waste may build up very quickly, the floor might be swept and inspected at the end of every shift, whereas weekly housekeeping might be more appropriate in an office.

### Legal Standards

- ILO C155 – Occupational Safety and Health Convention, 1981 (No. 155).
- ILO R164 – Occupational Safety and Health Recommendation, 1981 (No. 164).

**STUDY QUESTIONS**

14. Identify the main hazards causing slips, trips and falls on the same level.
15. Identify eight control measures that might be used to reduce the risk of slipping and tripping in the workplace.

(Suggested Answers are at the end.)

# Safe Movement of People and Vehicles in the Workplace

## IN THIS SECTION...

- Vehicle operations create risk for pedestrians as well as vehicle drivers and passengers. Hazards include:
  - Those relating to vehicle movement, which include driving too fast, reversing, quiet machinery and poor visibility.
  - Non-movement-related hazards, which include loading, unloading, securing and sheeting of loads, coupling and maintenance work.
- Common accidents involve collisions with pedestrians, vehicle overturn, and collisions with other vehicles or fixed structures.
- These hazards can be controlled through the risk assessment process and by careful management of the workplace environment, the vehicles and the drivers.
- The workplace environment should be designed, constructed and maintained to allow safe vehicle movement and to separate vehicles from pedestrians.
- Vehicles should be suitable for their intended use and workplace environment and maintained in safe working order.
- Drivers should be appropriately qualified, medically fit and given information, instruction, training and supervision.

## Risks Associated with Workplace Transport Operations

### Typical Risks Relating to Vehicle Movements

When vehicles move around in workplaces, they are a hazard to pedestrians, to other vehicles (and their occupants) and to the driver (and other occupants).

### Collisions

Collisions can occur between the vehicle and:

- Pedestrians (e.g. between a car in a staff car park and a member of staff leaving work).
- Other vehicles (e.g. between two lorries manoeuvring at a depot).
- Fixed objects (e.g. between a forklift truck and the support leg of racking in a warehouse).

Areas of particular concern are vehicle entrance and exit points, such as the forklift truck entrance point from an outside yard area into a workshop. These parts of a building tend to have a high incidence of vehicle collisions because of the:

- Bottlenecking of vehicles through these routes.
- Presence of blind spots (places that the driver cannot see).
- Change in light levels that usually occurs (from brightly lit to dark and gloomy, or the reverse) – the driver's eyes take a while to adapt to the new light level.



Forklift truck

Remember that some of the highest-risk situations occur when pedestrians have to interact with vehicles. Any collision between a vehicle and a pedestrian is likely to lead to serious or fatal injury.

### TOPIC FOCUS

Factors that increase the risk of vehicle collisions are:

- Driving too fast.
- Inadequate lighting.
- Reversing without the help of a banksman (signaller).
- Blind spots, such as corners and entrances.
- Bad weather conditions (e.g. rain).
- Obstructed visibility (e.g. overloaded forklift truck driving forwards).
- Poor design of pedestrian walkways and crossing points.
- Lack of vehicle maintenance (e.g. brake failure).

### DEFINITION

#### **BANKSMAN (SIGNALLER)**

A person used to guide a vehicle/plant driver/operator during vehicle/plant use (e.g. while reversing).

### Loss of Control and Overturning

A driver may lose control of their vehicle for various reasons:

- Driver error (e.g. driving too fast).
- Environmental conditions (e.g. mud on the road).
- Mechanical failure (e.g. brakes failing).

Depending on the type of vehicle being driven, this loss of control may result in a skid, collision or overturn of the vehicle.

Some vehicles, because of their design or environment of use, are more likely to overturn than others. Forklift trucks (with a very short and narrow wheel base) and dumper trucks (with a high centre of gravity and used on rough terrain) are frequently involved in overturn accidents.

When a vehicle overturns, the driver can easily be trapped or crushed between the vehicle and the floor unless precautions are taken to retain the driver in a safe location – this is why seat belts are so important.

### TOPIC FOCUS

Factors that can cause a forklift truck to overturn are:

- Cornering while being driven too fast.
- Uneven loading of the forks.
- Driving over potholes.
- Driving with the load elevated, especially cornering.
- Uneven tyre pressures.
- Driving across a slope (rather than straight up/down the fall line).
- Excessive braking.
- Collisions, especially with kerbs.

### Risk Factors

Vehicle accidents are responsible for many serious and fatal injuries and also cause a significant amount of property and equipment damage. The various risk factors are listed below, along with some typical conditions and environments in which each hazard might arise:

- **Driving too fast** – often associated with driver error, is a major cause of vehicle collisions and vehicles overturning. The effects of driving too fast are worsened by movements across uneven ground, sloping surfaces and around bends. Loads may move due to abnormal movements and fall from vehicles. Braking when driving too fast may be ineffective and more hazardous on wet, icy or slippery surfaces.
- **Reversing** – limits a driver's vision and puts the whole length of a vehicle in the direction of travel. Without rear-vision devices (such as cameras) or reversing alarms, drivers and pedestrians may not see or hear the approach of a vehicle.
- **Silent operation of machinery** – not only are vehicle engines more quiet but auxiliary machinery and equipment such as loaders, cranes, refrigeration plants, etc. are quiet and may not be heard by pedestrians or other drivers.
- **Poor visibility** – causes many collisions especially around loads, wide or long vehicles or while vehicles are reversing. Vehicle entrance and exit points also create blind spots and changes in light levels.

### Non-Movement-Related Hazards

Vehicles do not only present a hazard when they are moving. Some vehicle hazards occur when other types of activity are being carried out on the vehicle:

- **Loading** – manual and mechanical. For example, there is a manual handling risk associated with lifting crates into the back of a lorry, or a risk of collision when loading a flat-bed lorry using a forklift truck.
- **Overloading** – exceeding the safe working limit of the vehicle. This could be due to driver error, or through a lack of knowledge about the capabilities of the vehicle or the nature of the load. An unbalanced load can also destabilise the vehicle.
- **Unloading** – manual and mechanical. For example, tipping operations can result in the vehicle overturning or people being struck by the material being tipped.
- **Securing** – workers climbing onto a vehicle to secure the load. For example, a driver might have to climb onto the top of a lorry to sheet over the load to prevent it blowing out when moving at speed, or might have to climb onto the top of a road tanker to close hatches. Both of these operations involve work at height.

- **Coupling** – attaching vehicles to trailers or other towed equipment. This produces a potential for collision and crushing.
- **Maintenance work** – mechanics having to access various parts of the vehicle. They may have to work at height or under the vehicle.

## Workplace Transport Control Measures

The control strategies for managing the risk inherent in vehicle operations are based on the usual basic health and safety management principles:

- Eliminate the hazard.
- Create a safe place.
- Create a safe person.

The starting point is **risk assessment**.

### Risk Assessment

A risk assessment covering the vehicle operations in a workplace would:

- Identify the various hazards, by establishing the vehicle operations taking place in or from the workplace and the types of foreseeable accidents that might occur.
- Identify the groups at risk (pedestrians, the driver, other drivers, etc.) and those who might be especially vulnerable (young children, the elderly, people with certain disabilities, such as the visually impaired, etc.).
- Evaluate the risk by considering the existing controls, the adequacy of those controls and any further controls required to reduce the risks to an acceptable level.
- Be recorded and implemented.
- Be subject to review as the workplace changes, in response to incidents and perhaps periodically.

The measures necessary to control the risks created by vehicle operations can be grouped under three main categories:

- **Workplace environment.**
- **Vehicle.**
- **Driver.**

### The Workplace Environment

Careful design and construction of the workplace can eliminate or reduce the risks created by vehicle operations:

- **Vehicle-free zones** – it may be possible to eliminate the hazard by creating pedestrian-only areas.
- **Pedestrian-free zones** – since pedestrians are usually the group at greatest risk during vehicle manoeuvring operations, it may be possible to eliminate them from certain parts of the workplace.
- **Vehicle traffic route layout** – good design of roads and routes can be used to keep vehicles at a distance from pedestrian walkways and other vehicles, and this should include separate access doors for pedestrians and vehicles. One-way systems are an effective method of reducing the risk of vehicle-to-vehicle collisions.



Pedestrian direction sign

- Segregation of vehicles and pedestrians – wherever possible, pedestrians should be provided with a separate walkway. It may be necessary to barrier this route to provide additional physical protection. In some situations (such as in loading bays), areas of safety should be provided that pedestrians can retreat into during vehicle movements.
- Where barriers cannot be used, segregation might be achieved by marking pedestrian walkways on the floor.
- Separate site and building entrances should be provided for vehicles and pedestrians so that they are not forced into close proximity at these bottlenecks.
- Speed limits should be set for traffic routes and then clearly indicated by signage, and enforced. Traffic-calming measures, such as speed bumps, might be used where experience shows there is a problem with vehicles speeding.
- Vehicle movements on site should be managed. This may include implementing vehicle restrictions to reduce the number of vehicles on site, allocating booking slots for deliveries, etc. Banksmen (signallers) may be used to ensure that vehicle manoeuvres in the vicinity of pedestrians are carried out safely.
- Crossing points may be implemented to allow pedestrians to cross traffic routes safely.
- Good visibility is essential, so that drivers have unobstructed views from their vehicles. Blind spots should be eliminated by careful traffic route design; where this is not possible, aids such as mirrors, CCTV and transparent doors should be provided.
- Good standards of lighting should be present on traffic routes.
- Appropriate signage should be used to alert vehicle drivers to hazards on their route (such as lower overheads). Signage should also be used to warn pedestrians that there could be vehicles operating in the area.
- While barriers can protect pedestrians from vehicles, they can also be used to protect structures that might be at risk of damage or collapse in the event of a collision (e.g. in a warehouse, racking may be protected with barriers at vulnerable locations).
- Wherever there are changes in level (e.g. at loading docks), physical barriers should also be used to prevent a vehicle driving off the dock and falling.
- The surface of the traffic route must be suitable for the vehicles using it, with attention paid to its strength and stability, grip characteristics and drainage.
- Gradients should be avoided, but if this is not possible, they must not exceed the capabilities of the vehicle using the traffic route.

The above controls must also be reinforced by the implementation of **site rules** for drivers and pedestrians (strictly enforced and adhered to) and driver training, with information provided on the rules to visiting drivers, such as delivery drivers.

All these control measures should be **maintained** in good order. This may require routine inspection regimes, cleaning regimes and repair/replacement as necessary.

It will usually be necessary to develop **safe systems of work** for vehicle operations. These safe systems should identify the site procedures and rules that must be followed. For example, many workplaces prohibit vehicles from reversing without the aid of a banksman.

### TOPIC FOCUS

Control measures that can reduce the risk of accident from reversing vehicles include:

- Avoidance of reversing by implementing one-way traffic systems.
- Segregation of pedestrians and vehicles or the provision of refuges.
- Selection of good vehicles so that drivers have adequate visibility.
- Provision of audible reversing alarms and flashing beacons.
- Provision of mirrors at blind spots to see approaching pedestrians.
- Use of high-visibility clothing.
- Ensuring that the area is well lit.
- Provision of banksmen.
- Training for drivers and pedestrians working in the area.

Site rules may also have to be developed to cover simple issues such as safe vehicle parking.

### TOPIC FOCUS

Typical rules for parking a vehicle are:

- Apply the handbrake.
- Remove the key.
- Do not obstruct a traffic route.
- Do not obstruct a pedestrian route.
- Do not obstruct emergency escape routes.
- For a forklift truck lower the forks and tip the mast forwards.

These workplace design, construction and layout matters are subject to legal standards. For example, in the UK the **Workplace (Health, Safety and Welfare) Regulations 1992**. These contain the basic legal framework for traffic route construction and layout with an emphasis on the separation and segregation of vehicles and pedestrians.

### MORE...

More detailed information on workplace traffic route layout and safety can be found at:

[www.hse.gov.uk/workplacetransport](http://www.hse.gov.uk/workplacetransport)

## Safe Vehicles

The range of vehicles that might be used for work purposes is enormous – from cars, vans and lorries used on public roads to 200-tonne quarry trucks. In spite of this great variety of vehicles, there are some basic principles that can be applied.

### TOPIC FOCUS

Vehicles should be:

- Suitable for their intended use.
- Suitable for the environment and conditions in which they are used.
- Maintained in safe working order.
- Only driven by suitably trained, qualified staff.
- Inspected routinely before use.

And, where necessary, vehicles should be fitted with a(n):

- Seat for the driver (and any passengers).
- Seat belt.
- Roll bar or roll cage to protect the driver in the event of overturn.
- Guard to protect the driver in the event of falling objects (Falling Object Protective Structure (FOPS)).
- Horn.
- Set of visibility aids, such as cameras and mirrors.
- Audible reversing alarm to warn pedestrians.
- Beacon or flashing light to warn of an approaching vehicle.

### DEFINITION

#### ROLL BAR OR ROLL CAGE (ROLLOVER PROTECTIVE STRUCTURE)

Part of the structure of the vehicle that prevents the driver from being crushed, should the vehicle roll over onto its side or top; also known as a rollover protective structure (ROPS).

Vehicles used on **public roads** have to comply with the relevant local legislation, such as the **Road Traffic Act 1991** in the UK (e.g. requirements for road tax, appropriate insurance, working headlights, etc.). Vehicles used on **private land** (as with many workplaces) do not usually have to comply with the same public highway laws, but do have to meet specific legal standards relating to workplaces in general or a workplace in particular (e.g. vehicles used in a quarry should always be fitted with a yellow beacon (flashing light) and that light should always be working when the vehicle is operational).

For example, in a UK workplace, the **Health and Safety at Work, etc. Act 1974** and the **Management of Health and Safety at Work Regulations 1999** will apply. A vehicle is an item of work equipment and therefore subject to the **Provision and Use of Work Equipment Regulations 1998 (PUWER)**, most notably part 3 of **PUWER**, which applies specifically to mobile work equipment. The vehicle may also be an item of lifting equipment (e.g. a forklift

truck) and so subject to the **Lifting Operations and Lifting Equipment Regulations 1998 (LOLER)** as well. Relevant ACoPs and guidance will also apply.

A risk assessment may have to be completed to decide exactly which safety features a vehicle should have in a particular workplace in order to meet legal standards.

## Safe Drivers

Since there are very few instances where automated vehicles can be used in a workplace, vehicles are usually under the control of a driver. It is essential that the driver is carefully selected, trained and supervised.

Drivers should be:

- **Competent to drive the vehicle** – proof of qualification (e.g. driving licence) may be necessary or the driver may have to be trained and assessed to achieve qualification. Refresher training and re-certification may be required. In certain situations, the driver's licence may have to be checked periodically to ensure that the driver does not have undisclosed penalties or disqualification for road traffic offences.
- **Medically fit to drive** – a medical examination to assess the driver's health and fitness may be required. This should take place at selection and may have to be repeated periodically.
- **Provided with specific information, instruction and training** – appropriate to the workplace and site where they will be driving, driver-specific site induction training may have to be provided.
- **Supervised** – to ensure that they follow safe systems of work, obey site rules and do not lapse into bad practices.



Practising driving a pallet truck

The employer must make sure that an appropriate **management system** is in place to ensure driver competence as set out above. This management system should form a part of the policy arrangements for the organisation.

There are legal standards and codes of practice relating to these matters. For example, a forklift truck driver using a forklift on private land should be qualified to drive the relevant type of truck as indicated by the **ACoP L117 Rider-Operated Lift Trucks: Operator Training and Safe Use – Approved Code of Practice and Guidance** (a code of practice to **PUWER**).

### Legal Standards

For most workplaces:

- ILO C155 – Occupational Safety and Health Convention, 1981 (No. 155).
- ILO R164 – Occupational Safety and Health Recommendation, 1981 (No. 164).

For construction sites:

- ILO C167 – Safety and Health in Construction Convention, 1988 (No. 167).
- ILO R175 – Safety and Health in Construction Recommendation, 1988 (No. 175).

**STUDY QUESTIONS**

16. Identify the main types of risk associated with vehicle operations.
17. Identify the unsafe practices that might cause a forklift truck to overturn.
18. Identify the main safety measures used to manage vehicle operations and movement.
19. Identify special equipment that might be fitted to vehicles to protect drivers.
20. Identify when vehicle warning lights and alarms are particularly useful.
21. Outline the means of separating vehicles and pedestrians.

(Suggested Answers are at the end.)

## Work-Related Driving

### IN THIS SECTION...

- Organisations should establish clear policies on work-related driving safety and implement a road traffic safety management system.
- Risk assessment of work-related driving should follow the standard five-step approach for risk assessment. Factors to consider include the distance travelled, driving hours, work schedules, stressful situations and weather conditions.
- Evaluation of risk should focus on three things: the driver, the vehicle and the journey.
- Control measures to reduce driving risk include:
  - Elimination of the need to travel.
  - Use of alternative means of transport.
  - The management of the risk factors associated with the driver, vehicle and journey.
- The hazards of electric and hybrid vehicles include silent operation, high-voltage electricity and retained electric charge.

### Managing Work-Related Road Safety

This section looks at the issue of driving a vehicle on the public highway for work; for example, a company car. It does not focus specifically on large goods vehicles or passenger service vehicles, where specific legislation applies.

Managing work-related road safety requires that the employer integrates road safety into their existing safety management system. Road safety should be treated as simply another aspect of their general duty for the health and safety of their staff and third parties. This can be done by the establishment of a road traffic safety management system such as ISO 39001: *Road traffic safety management systems*. This uses the standard management cycle that was introduced earlier in the course: Plan, Do, Check and Act.

#### Plan:

- Assess the road traffic risks.
- Establish the organisation's policy.
- Ensure senior management involvement.
- Establish roles and responsibilities.

#### Do:

- Ensure any necessary cooperation between departments.
- Establish adequate systems in place, including maintenance strategies.
- Undertake necessary communication and consultation with the workforce.
- Provide adequate instruction and training.



Driving on a public highway

**Check:**

- Monitor performance to ensure the policy is working correctly.
- Ensure all workers report work-related road incidents or near misses.

**Act:**

- Review performance and learn from experience.
- Regularly review and update the policy.

## Risk Assessment Factors

Work-related driving should be risk assessed in the same way as other work-related activities. This will allow the employer to establish arrangements for controlling the risk. The standard five-step approach to risk assessment can be used:

1. **Identify the hazards** – these can be categorised as the factors associated with driving that increase the risk of being involved in a road traffic incident, namely:
  - **The journey distance** – the longer the journey, the greater the risk. Long journeys should be broken into shorter sections. Sections of a journey should also be of a comfortable length.
  - **Driving hours** – it may be tempting to drive for a long period without a break in order to get to the destination faster but this increases the risk of an accident due to fatigue and lapses of attention.
  - **Work schedules** – poor planning and unreasonable work schedules (which do not allow adequate time between appointments) can cause drivers to speed, take risks or fail to take breaks.
  - **Stress** due to traffic – times of journeys can place a driver in ‘rush-hour’ traffic on major and suburban roads, and road works or traffic incidents can cause unscheduled delays.
  - **Weather conditions** – adverse weather conditions can increase the risk to those driving. For example:
    - Snow can cause the roads to be slippery and reduces visibility.
    - Fog affects visibility.
    - High winds are particularly hazardous to drivers of high-sided vehicles.
2. **Identify the people who might be harmed** – the driver, but may also include passengers and other road users. Certain groups might be more at risk, such as young drivers.
3. **Evaluate the risks** – the level of risk must be estimated and decisions made about appropriate control measures. A standard hierarchical approach can be adopted:
  - Eliminate the need to travel (e.g. conduct web-based videoconference calls rather than meeting face-to-face).
  - Travel by a safer means of transport (e.g. train or aeroplane).
  - If travel by road is the only sensible option, then ensure that the vehicle is appropriate, in a safe condition and that the best person is driving. Various arrangements can be made through the company policy to ensure that both the vehicle and the driver meet the required standards (see later).
4. **Record** findings and implement them.
5. **Review** – the risk assessment should be reviewed following incidents, after significant change and periodically.

## Evaluating the Risks

Evaluating the risks means looking at what controls are in place already – are they enough to reduce the risks to an acceptable level, or does more need to be done? The risk evaluation should look particularly at the driver, the vehicle and the journey, and consider the risk factors that might exist under each topic as seen above:

- **The driver:**
  - Competency.
  - Training.
  - Fitness and health.
- **The vehicle:**
  - Suitability.
  - Condition.
  - Safety equipment.
  - Safety-critical information.
  - Ergonomic considerations.
  - Mobile phone use.
- **The journey:**
  - Routes.
  - Scheduling.
  - Sufficient time.
  - Weather conditions.

## Control Measures

Control measures can then be identified that would be appropriate for each risk factor. Some of these control measures require that specific management arrangements are put in place, while others require that guidelines are prepared and passed on to drivers. In some instances, there may be clear statutory requirements that must be met. In many cases, however, the employer has to base their control measures on good practice.

### The Driver

Three main risk factors exist for the driver:

- **Competency** – drivers should hold the relevant driving licence for the vehicle to be driven. They might also be required to demonstrate relevant experience, skills and knowledge:
  - Drivers' licences should be checked on recruitment and re-checked periodically (e.g. every six months) to ensure validity.
  - Some organisations set minimum standards regarding endorsements on company driving licences.
  - Some organisations take up references for proof of relevant experience and ability.
- **Training** – drivers may have to undertake specific training on safe driving:
  - Some organisations require their drivers to undertake advanced driving or defensive driving training and assessments.

- Some organisations train their drivers on vehicle safety, such as pre-use vehicle inspection, use of anti-lock braking, head restraint adjustment (to prevent whiplash injury), etc.
- **Fitness and health** – drivers may have to undergo a medical examination and be passed as fit to drive:
  - For certain drivers, such as those driving heavy vehicles and buses, this medical examination and certification is a legal requirement.
  - For some organisations, medical examination is a matter of company policy.
  - Drivers' eyesight might need to be checked.
  - Drivers should be reminded about not driving while taking certain drugs that cause drowsiness.

## The Vehicle

The main risk factors for the vehicle are:

- **Suitability** – the vehicle must be suitable for its intended purpose:
  - Some organisations set a minimum requirement for the safety standards of the vehicle (e.g. as determined by Euro New Car Assessment Programme (NCAP) crash test (see 'More' box)).
  - Some organisations set minimum standards for safety features, such as anti-lock braking, airbags, headrests and seat belts.
  - A personal vehicle should only be used for work if it has a valid regulatory certificate where required (e.g. an MOT certificate in the UK, which checks certain roadworthy features of a vehicle of a certain age) and is insured for work use.
- **Condition** – the vehicle must be in a roadworthy condition:
  - Vehicles should be maintained in accordance with the manufacturer's recommended service schedule.
  - Vehicles should be routinely inspected prior to use to check the condition of tyres, lights, etc.
  - Vehicle defects should be reported and corrected where safety-critical.
- **Safety equipment** – the vehicle should carry suitable safety equipment:
  - Seat belts, airbags and head restraints are fitted as standard in many vehicles; they should be in good order.
  - Other safety equipment may be specified by the employer, such as emergency triangle, first-aid kit, spare tyre and fire extinguisher.
- **Safety-critical information** – certain information must be understood by the driver:
  - Tyre pressure, headlight adjustment and head restraint adjustments are examples of safety-critical information that the driver should know.
- **Ergonomic considerations** – the adjustability of the seat position and vehicle controls, as well as driver posture, should be considered when selecting vehicles to ensure driver comfort and to minimise the risk of back pain and other musculoskeletal disorders.
- **Mobile phone use** – company policy must be established and implemented on the safe use of mobile phones.



Vehicle testing and maintenance

## The Journey

There are also several considerations relating to the journey that need to be taken into account when determining control measures:

- **Routes** – route planning allows for hazards to be avoided and risks minimised:
  - Hazards, such as busy areas (e.g. a town centre) or high-risk areas (e.g. accident black-spot), can be avoided.
  - Low-risk roads can be selected. Motorways and dual carriageways (also known as divided highways) are the safest roads.
  - Roadworks can be avoided.
- **Scheduling** – scheduling journeys at the right time of day:
  - Avoid travelling at peak traffic times.
  - Avoid travelling when drivers will feel naturally fatigued (2:00–6:00am and 2:00–4:00pm).
  - Allow flexibility of deadlines.
- **Time** – allowing sufficient time for the journey:
  - Time allowed must be realistic given the route chosen, weather conditions and anticipated breaks.
  - Unrealistic deadlines put pressure on drivers to speed. Rest breaks must be factored into journey times. A 15-minute break every two hours is recommended.
  - There are statutory requirements for professional drivers.
- **Distance** – travel distances must be reasonable:
  - It may be possible to minimise travel distances by using other forms of transport for some of the journey.
  - Distance must not be excessive and consideration should be given to the length of the driver's day outside of driving time.
- **Weather conditions** – weather forecasts and adverse weather conditions must be taken into account when journey planning and travelling. Drivers should:
  - Have access to reliable weather forecast information so that they can journey plan accordingly.
  - Be given guidance on adverse weather conditions when they should not travel.
  - Be given advice on additional safety during adverse weather.



Roadworks

### MORE...

Browse the following websites to read more on work-related road safety:

[www.hse.gov.uk/roadsafety](http://www.hse.gov.uk/roadsafety)

[www.drivingforbetterbusiness.com](http://www.drivingforbetterbusiness.com)

Details about the Euro NCAP crash test can be found at:

[www.euroncap.com/en](http://www.euroncap.com/en)

[www.euroncap.com/tests.aspx](http://www.euroncap.com/tests.aspx)

## Hazards of Electric and Hybrid Vehicles

Electric and hybrid vehicles (i.e. vehicles with an electric motor and a combustion engine) have a range of hazards associated with them:

- **Silent operation** – electric vehicles are often silent running and therefore cannot be heard by pedestrians and other road users, such as cyclists, increasing the risk of collision.
- **Unexpected engine start-up** – hybrid vehicles are capable of automatic engine start-up when the battery charge is low. This can happen even though the vehicle appears to be switched off.
- **High-voltage electricity** – electric and hybrid vehicles use electrical systems that run at high voltage (up to 650 V DC) and are capable of causing significant electric shock, explosion and/or burn injuries that can be fatal.
- **Charge retention** – some components within the vehicle systems are capable of retaining electric charge for a period of time (up to 10 minutes). This presents a risk of electric shock even when the vehicle is switched off or battery disconnected.
- **Batteries** – can explode or release hazardous substances if not handled in accordance with manufacturer's guidelines.
- **Manual handling** – batteries are very heavy and present a significant manual handling risk if they have to be removed or swapped out.
- **Magnetic forces** – it is possible that the motor, drive chain or vehicle may move due to magnetic forces within the motor.

The above hazards are compounded by the fact that remote key operating systems are common in these types of vehicle – so the key does need to be in the ignition for the vehicle to be operational. This presents a particular risk for workers involved in vehicle maintenance, recovery and the emergency services.

Another issue that can cause problems with the use of electric vehicles is the availability and location of charging points.

### Legal Standards

- ILO C155 – Occupational Safety and Health Convention, 1981 (No. 155).
- ILO R164 – Occupational Safety and Health Recommendation, 1981 (No. 164).
- ILO C153 – Hours of Work and Rest Periods (Road Transport) Convention, 1979 (No. 153).
- ILO R161 – Hours of Work and Rest Periods (Road Transport) Recommendation, 1979 (No. 161).

### STUDY QUESTIONS

22. Identify the first option to consider when controlling driving risk.
23. Identify the three main areas of concern that can be managed by the risk assessment process.
24. Identify three risk factors associated with the journey.

(Suggested Answers are at the end.)



## Summary

---

This element has dealt with some of the hazards and controls relevant to the workplace environment.

In particular, this element has:

- Outlined minimum welfare provision as: access to drinking water, sanitary conveniences, washing facilities, changing rooms and accommodation for clothing, and places to rest and eat food.
- Identified basic workplace environment standards for seating, ventilation, heating and lighting.
- Outlined the effects of working in extreme temperatures and relevant control measures.
- Described the main risks associated with work at height as falls and falling objects, created by hazards such as fragile roofs, sloping roofs, deteriorating materials, unprotected edges, unstable access equipment and adverse weather conditions.
- Outlined how work at height should be avoided, engineering measures (e.g. edge protection) used to prevent falls, and measures taken to minimise the distance and consequences of a fall (e.g. safety nets).
- Discussed the hazards and precautions relevant to scaffolds, mobile tower scaffolds, MEWPs and ladders, as well as the inspection requirements for such equipment.
- Identified a confined space as any place which has an enclosed nature and a risk of fire or explosion; loss of consciousness or asphyxiation arising from gas, fumes, vapour or lack of oxygen; drowning; asphyxiation as a result of entrapment in a free-flowing solid; or loss of consciousness as a result of increased body temperature.
- Outlined how, before entry into a confined space takes place, a risk assessment must be carried out by a competent person to consider the hazards created by the condition of the space itself, the work activities to be carried out and those outside the space.
- Outlined how all entries into confined spaces must be done under a comprehensive safe system of work that will usually include the use of a permit-to-work system and provision for emergency rescue and first aid.
- Identified lone workers as 'workers who are separated from their work colleagues'.
- Outlined how lone working activities must be risk assessed and the risk eliminated or controlled by the use of a safe system of work.
- Outlined the key issues for the safe system of work as adequate levels of training, supervision and monitoring.
- Outlined the slip and trip hazards that pedestrians are exposed to as they move around the workplace.
- Noted how these hazards can be controlled by the risk assessment process and by careful design, construction and operation of the workplace.
- Identified key controls such as:
  - The use of non-slip surfaces.
  - Spill control and good drainage.
  - Designating pedestrian walkways.
  - Signs and PPE.
  - Information, instruction, training and supervision.
  - Good housekeeping, routine inspection and maintenance routines.
- Identified the hazards presented by vehicle operations and categorised them as collisions with pedestrians, vehicle overturn or collisions with other vehicles or fixed structures.



- Explained how these hazards can be controlled through the risk assessment process and by careful management of the workplace environment, vehicles and drivers.
- Outlined how the workplace environment should be designed, constructed and maintained to allow safe vehicle movement and to separate vehicles from pedestrians.
- Identified key requirements for vehicles: they must be suitable for their intended use and workplace environment and maintained in safe working order.
- Noted some key requirements for drivers: they must be appropriately qualified, medically fit, and given appropriate information, instruction, training and supervision.
- Outlined the relatively high-risk nature of work-related driving on the roads and the need for organisations to establish clear work-related driving safety management systems.
- Explained how the risk assessment of work-related driving should focus on three main areas of concern: the driver, the vehicle and the journey, each of which has various risk factors associated with it.
- Described some of the control measures to reduce driving risk, such as the elimination of the need to travel, use of alternative means of transport and the management of the various risk factors associated with the driver, vehicle and journey.
- Outlined the hazards associated with electric and hybrid vehicles.

# Practical Assessment Guidance

## Part 2 – Risk Assessment (Continued)



In the Practical Assessment Guidance at the end of the last two elements, we looked at the risk assessment table (Part 2 of the form) that you are required to complete and dealt with the first four columns which were concerned with hazard categories and hazards, who might be harmed and how, current control measures and additional control measures.

In the next part of the guidance, we will look at the final two columns of the risk assessment table which are concerned with allocating timescales and responsibilities to the further actions required.

### The Part 2 Form (Continued)



**Part 2: Risk Assessment**

Organisation name:  
 Date of assessment:  
 Scope of risk assessment:

Hazard category and hazard	Who might be harmed and how?	What are you already doing?	What further controls/actions are required?	Timescales for further action to be completed (date)	Responsible person's job title

Learned number:

Learned name:

Page 2 of 6

**Note:** These forms are for reference purposes only. Please visit the NEBOSH website to obtain the official forms to submit your assessment.

The final step in completing the Part 2 risk assessment form is to allocate a timescale and a responsible person to each of the additional control measures identified in column 4. This information is recorded in columns 5 and 6.

## Column 5: Timescales

When you are filling in the 'Timescales' column, make sure that you write in lengths of time and not deadline dates. You can use any timescale you like (such as 1 day, 3 days, 1 week, 2 weeks, 3 months, 8 months, 1 year, etc.) but do not put deadline dates (such as 30 September 2020) and do not write 'as soon as possible' or 'ASAP' – this is not a timescale.

When you are allocating timescales, think about two separate issues:

- What is the current level of risk presented by the hazard and how urgently is further action required?
  - A poorly controlled hazard presenting significant risk, where a single action will make a difference to the risk level, will be a high priority.
  - A well-controlled hazard presenting little risk, where an additional control measure has been identified, will be a low priority.

- How easy is it to carry out the additional action from a practical point of view?

Some actions are very quick and easy to do. They cost little money and can be done within minutes or an hour or two. Other actions require major capital expense (which takes time to gain approval for), or they are difficult and time-consuming to do.

Both of these issues will make a difference to the timescales that you allocate. So an action that is high priority and quick, cheap and easy to do, should be allocated a very short timescale (perhaps 1 or 2 days). Conversely, a lower priority action that is difficult and time-consuming should be allocated a longer timescale (perhaps months).

The key issue is that the examiner should be able to see that the timescales you are setting look practical and realistic and, most importantly, address the risk presented by each hazard in a proportionate way.

## Column 6: Responsibilities

When you are allocating responsibilities for each of the further actions required, you must use people's job roles or job titles. Do **not** write down personal names or initials in this column. You can identify the responsible person by any job role or title. Be aware that sometimes large organisations have unusual job titles, so the examiner may not know what that job role is. So simplify job titles if you need to. Job role/titles such as 'Office Manager', 'Warehouse Team Leader', 'Area Co-ordinator', 'Production Manager', 'Operations Director' and 'Chief Executive' are the sorts of titles that might be used. In a military organisation, the person's rank might be used.

Bear in mind that some actions can and will be given to junior managers, such as supervisors or team leaders. Other jobs will be given to middle managers, such as area managers. And some jobs can only be done by senior managers, such as directors. The nature of the action will determine at which level, within the organisation, the responsibilities are allocated.

Inevitably there will be key people who will probably end up with many of the further actions allocated to them. This should not concern you. The key issue is that the examiner must see that you are allocating the right actions to the right people at the right levels in your organisation.

You may find that one hazard requires several different actions, and that these need to be allocated to different people. If you number each action in column 4, you can write down the action number next to the job title in column 6. For example, 'Operations Manager – actions 1, 3, 4, 7 & 9'; 'Maintenance Manager – actions 2, 5, 6 & 8'. You don't have to do this, but it might help with some very 'action-dense' hazards.

Finally, remember to put the organisation name, risk assessment date and risk assessment scope at the top of the risk assessment form.

The next step of practical assessment – selecting three actions for urgent attention – will be dealt with at the end of Element 9.

# Work Equipment



## Learning Objectives

Once you've studied this element, you should be able to:

- 1 Describe general requirements for work equipment.
- 2 Explain the hazards and controls for hand-held tools.
- 3 Describe the main mechanical and non-mechanical hazards of machinery.
- 4 Explain the main control measures for reducing risk from machinery hazards.

<b>General Requirements for Work Equipment</b>	<b>9-3</b>
Types of Work Equipment	9-3
<b>Hand Tools and Portable Power Tools</b>	<b>9-9</b>
Hazards and Controls for Hand Tools	9-9
Hazards and Controls for Portable Power Tools	9-10
<b>Machinery Hazards</b>	<b>9-12</b>
Mechanical and Non-Mechanical Hazards	9-12
<b>Control Measures for Machinery Hazards</b>	<b>9-17</b>
Machinery Safeguarding Methods	9-17
Specific Machinery Examples – Hazards and Control Measures	9-24
Requirements for Guards and Safety Devices	9-29
<b>Summary</b>	<b>9-31</b>
<b>Practical Assessment Guidance</b>	<b>9-32</b>

# General Requirements for Work Equipment

## IN THIS SECTION...

- Work equipment covers a wide range of hand-held tools, power tools and machinery.
- Work equipment should be suitable for the task it is being used for and the environment it is used in.
- Access to dangerous parts of machinery should be prevented and safeguards applied according to a hierarchy of control measures.
- It is often necessary to restrict the use of work equipment to competent operators.
- Information, instruction and training should be provided for equipment users, managers and maintenance staff.
- Equipment controls should be clearly labelled and accessible; this is particularly important for stop controls and emergency stops.
- Work equipment should be maintained in safe working order and maintenance activities carried out safely.
- Routine inspection of equipment is sometimes necessary to ensure its safe condition.
- Work equipment should be stable, adequately marked with appropriate warning signs and devices, and environmental factors, such as lighting and space, should be managed.

## Types of Work Equipment

Note that in this element the phrase '**work equipment**' will be used in a very wide sense to include:

- Simple hand tools (e.g. a hammer, screwdriver or chisel).
- Hand-held power tools (e.g. a portable electric drill or circular saw).
- Single machines (e.g. a bench-mounted abrasive wheel, photocopier, lathe or compactor).
- Mobile work equipment (e.g. a tractor or mobile crane).
- Machine assemblies, where several machines are linked together to form a more complex plant, such as a bottling plant.

This broad use of the phrase 'work equipment' is in keeping with the definition used in EU directives and, in the UK, the **Provision and Use of Work Equipment Regulations 1998 (PUWER)**, perhaps the most important set of UK regulations relevant to this particular topic.



Hand-held power tool

## Suitability

When an employer provides work equipment for use at work, that equipment must be **suitable**. This means it must be suitable for the:

- **Task** it is going to be used to perform (e.g. a chisel is not appropriate for prising lids off tins).
- **Environment and conditions** in which it is to be used (e.g. a standard halogen spotlight is not suitable for use in a flammable atmosphere).

Equipment must be carefully selected to ensure that it is suitable for the task and environment on the basis of manufacturers' information.

In many regions of the world, there are regulations that require **manufacturers** to ensure that the equipment they produce meets basic safety standards. For example, in the EU, the **Machinery Directive (2006/42/EC)** establishes the basic safety standards that manufacturers are legally obliged to meet. Manufacturers are required to:

- design and manufacture machinery so that it meets 'essential health and safety requirements';
- create a **technical file** which should contain the information required to show that the product properly complies with the requirements of the directives that apply to it;
- fix a *Conformité Européenne* (CE) mark to the equipment;
- provide a written **Declaration of Conformity** for the purchaser; and
- provide written information on the hazards, risks, and safe use and maintenance of the equipment.



CE mark

In the UK, this Directive is implemented through the **Supply of Machinery (Safety) Regulations 2008**.

Employers in the EU have to ensure that any equipment they purchase for work use has this CE mark and written declaration.

## Preventing Access to Dangerous Parts of Machinery

Access to dangerous parts of machinery should be prevented. The safeguards that are used to prevent access to dangerous machine parts should be applied using a hierarchy of control measures. (Practical machinery safeguarding will be discussed later in this element.)

The hierarchy of control measures is best understood by looking at a specific hierarchy created by the UK **PUWER**. Regulation 11 sets out the methods by which this must be achieved, through provision of:

- Fixed, enclosed guards that encase or surround the dangerous part.
- Other guards and protection devices such as interlocked guards, self-adjusting guards, adjustable guards, pressure mats, trip devices and two-hand controls.
- Protection appliances such as jigs, holders and push-sticks.
- Information, instruction, training and supervision.

Every one of these precautions has to be used where, and to the extent that it is, **practicable**. 'Practicable' in this context means that if it can be done (i.e. it is possible), then it must be done.

## Restricting Use

Use of work equipment should, where necessary, be restricted to competent operators only. This relates to all equipment where risk of serious injury to the operator or to others exists. For example, forklift truck use must be restricted to trained, competent drivers. In addition, repair, modification or maintenance of equipment should similarly be restricted to designated competent people. For example, routine planned preventive maintenance of a forklift truck should be carried out by a competent vehicle mechanic.

## Information, Instruction and Training

**Work equipment users** should be provided with appropriate information, instruction and training:

- Where the equipment is **low risk**, this requirement is simple to fulfil. For example, an office paper shredder can be used by staff who have read the instructions supplied by the manufacturer.

- With **high-risk** machinery, more has to be done to fulfil this requirement to an acceptable standard. For example, an employer operating an industrial shredder capable of shredding wooden pallets should ensure that all operators receive specific training in the safe use of the equipment, as well as written information. They should also check to ensure understanding of that training and information.

### TOPIC FOCUS

Users of work equipment should:

- Only operate equipment they are authorised to use.
- Operate equipment in accordance with instruction and training.
- Only use equipment for its intended purpose.
- Carry out all necessary safety checks before using equipment.
- Not use the equipment if it is unsafe.
- Report defects immediately.
- Not use equipment under the influence of drugs or alcohol (this includes some medication which causes drowsiness).
- Keep equipment clean and maintained in safe working order.

Users will, therefore, have to be provided with appropriate information, instruction and training so that they are able to understand and follow these requirements.

Those involved in the **management of operators** should be given adequate information, instruction and training to allow them to effectively manage.

As a minimum, they should understand the basic principles of the safe use of the equipment.

**Maintenance staff** should be given specific information, instruction and training so that they:

- Can undertake any maintenance activities with a minimum of risk to themselves and others.
- Understand the maintenance requirements of the equipment and are able to keep the equipment in safe working order.

### Maintenance Requirements

Work equipment should be maintained in a safe working condition, according to relevant legal standards (such as **PUWER**) and manufacturers' recommendations.

Maintenance can be carried out according to various regimes, such as:

- **Planned preventive maintenance** – where servicing work is carried out at prescribed intervals and parts are replaced or changed, irrespective of their condition. For example, oil in an engine might be changed every year regardless of the amount of use that the engine has received.



Engineer carrying out condition-based maintenance

- **Condition-based maintenance** – where servicing is carried out and parts changed only when inspection indicates that use has caused deterioration. For example, the brake pads on a car might be inspected every 6,000 miles but only changed when they show signs of heavy wear.
- **Breakdown maintenance** – where maintenance is only carried out during repair.

Whatever type of maintenance regime is used for an item of work equipment, maintenance staff must not be exposed to unacceptable risk during maintenance work.

Maintenance work often creates greater risk for the staff involved because:

- Guards and enclosures have to be removed to allow access.
- Safety devices have to be removed or disabled.
- Equipment has to be partially or completely dismantled.
- Power sources may be exposed (e.g. an electrical supply).
- Stored power may be accidentally released (e.g. a compressed spring).
- Access may be awkward (e.g. space constraints or work at height).
- Handling of parts may be difficult (e.g. heavy parts).
- Additional hazards may be introduced (e.g. power tools).
- Workers may be under pressure to complete the job, especially in the case of breakdown maintenance.

A safe system of work should be developed for when maintenance work is carried out, and this may require the use of a permit to work and adequate levels of supervision (as discussed in Element 3).

For some items of work equipment, it is foreseeable that deterioration of safety-critical parts might occur and it is possible for these parts to be inspected without dismantling the equipment. It may be necessary to introduce some form of inspection regime. For example, the tyres on a vehicle might go flat or become excessively worn and it is an easy matter for the driver of the vehicle to carry out a pre-use inspection to check their condition.

### TOPIC FOCUS

Additional precautions may be required during maintenance work:

- Maintenance should only be carried out by competent staff.
- Power sources should be isolated and physically locked off (secured).
- Stored power should be released or secured to prevent accidental discharge.
- Where power cannot be isolated, additional precautions are required, for example:
  - Covering live parts with insulating material.
  - Using additional Personal Protective Equipment (PPE), such as insulating rubber gloves.
- If dangerous moving parts have to be accessed, additional precautions required are to:
  - Run at a very slow speed rather than normal operating speed.
  - Fit maintenance guards that have been made specifically to allow minimum access to required areas only.
- Precautions should be taken to allow safe access, especially when working at height.
- Handling aids and equipment should be used to reduce manual handling risk.

In certain instances, this routine inspection should be combined with a more detailed periodic examination and testing. For example, pressure systems, such as boilers and air receivers, must be thoroughly examined and tested because they are subject to very heavy stresses, and if parts were to fail they would fail catastrophically, leading to explosion. Periodic examination and testing of pressure systems should be carried out by a competent engineer and, in some cases, 'competence' and the standard of examination required is defined in legislation and codes of practice.

## Equipment Controls and Environmental Factors

Equipment controls, such as 'stop' and 'start' buttons, should be:

- Well designed so they are easy to use.
- Placed at suitable locations on the equipment.
- Easily identifiable.
- Kept in good working order.
- Compliant with relevant standards.

It is particularly important that 'stop' controls are easy to see and reach and that they override all other controls. By comparison, 'start' controls are usually recessed and harder to operate accidentally.

Many machines should also have emergency stops fitted. These are controls that bring the equipment to a safe stop as quickly as possible. Emergency stops can be buttons or pull cords and should be positioned on or by the equipment, within easy reach of operators. For large machines, this means that several emergency stop buttons may be fitted at various locations around the machine.

In addition to the requirements outlined earlier, there are some other basic physical requirements that work equipment should meet.

It should:

- Be stable – this may mean bolting it to the floor or fitting outriggers, jacks or stabilisers.
- Be appropriately marked – with labels on control panels, safe working loads, maximum speeds, etc.
- Have appropriate warnings – such as warning signs by dangerous parts and, in some cases, visible and audible warnings, such as flashing beacons and klaxons to warn of the start-up or movement of machinery.

The physical environment around the work equipment must also be considered; in particular, lighting and space.

## Lighting Considerations

When working with equipment, consider the following:

- Adequate general workplace lighting should be provided around equipment for the safety of both operators and others in the vicinity.
- Local lighting, such as spotlights positioned above machinery, might be required to give higher levels of light on critical areas.
- Lighting should be suitable for the type of equipment in use; avoid lights that flicker when illuminating rotating machinery because of the 'stroboscopic effect' where the rate of flicker coincides with the rotation rate of the machinery, giving the impression that the machinery is rotating very slowly when in reality it is rotating quickly.
- Lighting should be suitable for the environment (e.g. intrinsically safe lighting used in a flammable atmosphere).



Emergency stop button

## Markings

All work equipment has to be marked in a clearly visible manner, giving any relevant health and safety information, such as:

- 'Stop' and 'start' controls.
- Abrasive wheel rotation speeds.
- Safe working loads.
- Colour coding of gas cylinders for recognition of contents.
- Contents of storage vessels and nature of hazardous contents.
- Colour coding of pipework.

## Warnings

All work equipment should incorporate any warnings or warning devices that are appropriate for health and safety. These can be in the form of notices, requirements within permit-to-work systems and safety signs. The presence of a safety sign warning (e.g. of moving parts) does not remove the need for guarding. Warnings are a useful indication but not a replacement for physical protection.

## Space Considerations

These considerations include:

- Operators should have adequate space to move around work equipment safely.
- Other people should be able to move around safely without coming into close proximity to dangerous parts or presenting a hazard to the operator.

### MORE...

The HSE website contains more information on workplace equipment and machinery at:

[www.hse.gov.uk/work-equipment-machinery](http://www.hse.gov.uk/work-equipment-machinery)

## Legal Standards

- ILO C155 – Occupational Safety and Health Convention, 1981 (No. 155).
- ILO R164 – Occupational Safety and Health Recommendation, 1981 (No. 164).
- ILO C119 – Guarding of Machinery Convention, 1963 (No. 119).
- ILO R118 – Guarding of Machinery Recommendation, 1963 (No. 118) (to be revised).

## STUDY QUESTION

1. Why are maintenance workers sometimes at greater risk than operators when working on machinery?

(Suggested Answer is at the end.)

# Hand Tools and Portable Power Tools

## IN THIS SECTION...

- Simple hand tools can cause injury through user error, misuse or mechanical failure.
- Safe use of hand tools requires user training, compliance with safety rules, and routine inspection and maintenance of the tools.
- Portable power tools present greater risks because of the severity of injury that might be caused and the additional hazards presented by each tool.
- Safe use of power tools requires the same basic approach as that for hand tools, but with greater emphasis on user competence, supervision and maintenance, with additional precautions being introduced to combat each of the hazards associated with a tool and its power source.

## Hazards and Controls for Hand Tools

Simple hand tools (or hand-held tools) – such as a hammer, chisel or screwdriver – present relatively simple hazards:

- The tool may shatter during use, throwing off sharp metal fragments (e.g. a hammer head or chisel blade).
- The handle may come loose during use (e.g. the axe head comes off the handle).
- The tool may be blunt, leading to use of excessive force which causes loss of control (e.g. a blunt knife).
- Simple human error, where the user misjudges a movement (e.g. they hit their thumb with a hammer).
- The tool may be misused, i.e. used in an inappropriate way or for an inappropriate task (e.g. a screwdriver used as a crowbar).



There are hazards associated with simple tools such as hammers

Some relatively simple precautions can therefore be applied to ensure safe use of hand tools:

- Tools must be **suitable** for the **task** that they are going to perform and for the **environment** in which they are to be used, e.g. non-sparking tools (which do not produce sparks when struck) are suitable for use in a potentially flammable atmosphere.
- Users should be given appropriate **information, instruction** and **training**. Many workers serve some form of apprenticeship or spend several years in training where they acquire an understanding of safety in the use of the tools for their trade, but not all workers come to the workplace with this knowledge (which may seem like common knowledge to others).
- Tools should be **visually inspected** routinely before use to ensure they are in an acceptable condition. This should be done by the user. Spot checks by line management will ensure that users comply.
- Substandard tools should be **repaired** or **discarded**.
- Tools should be **maintained** in a safe condition (e.g. blades should be kept sharp and handles firmly attached).
- **Supervision** is important to ensure that safe working practices are adhered to and misuse does not become commonplace.

## Hazards and Controls for Portable Power Tools

Portable power tools include items such as drills, sanders, portable grinding wheels and portable power saws, and are commonly used in the construction and maintenance sectors.

Portable power tools create greater risk than simple hand tools because:

- The forces generated by the tool are far greater, so the potential for very severe injury or death exists (a ruptured disc from a disc cutter will cut off an arm, which would not happen when using a handsaw).
- Power tools have additional hazards not present with simple hand tools.

Additional hazards from portable power tools are:

- Electricity – which may result in electric shock, burns, arcing or fire.
- Fuel – usually petrol, which creates a fire and explosion risk.
- Noise – which may cause hearing loss.
- Vibration – which may cause hand-arm vibration syndrome (see Element 5).
- Dust – which is harmful if inhaled.
- Ejection – of material (e.g. brick fragments) or tool parts (e.g. cutting disc fragments).
- Trip hazards – from power cables.

Because the risks created by portable power tools are greater than those associated with simple hand tools, the safety precautions are more stringent. Management should make sure that:

- Tools are carefully selected to ensure **suitability** for the **task** and the **environment**.
- **Instructions** and safety rules are available in the form of manufacturers' handbooks or in-house safe working procedures.
- Operators are **trained** and given **information** on safe use of the tool. Operator competence is a key control that should be verified.
- Operators are **supervised** to ensure safe use.
- Tools are routinely **inspected** by the operator before use. Additional formal inspections should be carried out by the supervisor or maintenance staff.
- Substandard tools are **repaired** or **discarded**.
- Tools are **maintained** in safe working order. This might be done according to a maintenance schedule.
- Maintenance is carried out by **competent personnel** only and records should be kept. The tool might be labelled to indicate the date of the next maintenance.

In practice, safe use of a portable power tool requires that:

- Tools and parts are only used for their intended purpose, within their design specification (e.g. the maximum speed of a cutting disc should not be exceeded) and in an environment that they are suitable for.
- Necessary guards and safety devices are always used (e.g. the self-adjusting guard fitted to a portable circular saw).
- Necessary PPE is always used (e.g. eye protection when using a chainsaw).



Construction worker using a portable power tool

- Trailing power cables or pipes are carefully positioned so that they do not present a trip hazard and will not be damaged by the tool or passing vehicles, etc.
- Care is taken to ensure that ejected parts do not present a risk to others nearby. This may require that the area is fenced or cordoned off or that the tool is only used at specific times.
- Dust exposure is controlled, either by damping down or by the use of respiratory protective equipment by the operator and others nearby.
- Noise exposure is controlled (e.g. by using hearing protection (see Element 3)).
- Vibration exposure is controlled (e.g. by job rotation or limiting the duration of tool use (see Element 5)).

Additional precautions are necessary when storing and handling petrol. It should be **stored** in an appropriate, labelled metal container in a well-ventilated, secure area away from ignition sources. It should be **handled** with care in a well-ventilated area (preferably outside) away from ignition sources. Any spillages should be dealt with immediately.

Additional precautions must be taken when using electrical equipment. Battery-operated tools might be used, or a low-voltage supply (e.g. 110 V rather than 230 V). Damage to the electrical flex must be avoided.

The tool, flex and plug should be routinely inspected by the operator prior to use. It should also be given a formal electrical safety inspection, and thorough examination and test (see Element 11).

### Legal Standards

- ILO C155 – Occupational Safety and Health Convention, 1981 (No. 155).
- ILO R164 – Occupational Safety and Health Recommendation, 1981 (No. 164).
- ILO C119 – Guarding of Machinery Convention, 1963 (No. 119).
- ILO R118 – Guarding of Machinery Recommendation, 1963 (No. 118) (to be revised).

### STUDY QUESTIONS

2. Identify:
  - (a) Three likely causes of accidents involving simple hand tools.
  - (b) Why greater risk arises from the use of portable power tools.
3. Why might each power tool be marked?

(Suggested Answers are at the end.)

## Machinery Hazards

### IN THIS SECTION...

- The mechanical hazards of machinery are: crushing, shearing, cutting or severing, entanglement, drawing in or trapping, impact, stabbing or puncture, friction or abrasion, and high-pressure fluid injection.
- The non-mechanical hazards of machinery are: electricity; noise; vibration; hazardous substances; radiation (ionising and non-ionising); extreme temperatures; ergonomics; slips, trips and falls; and fire and explosion.
- All machinery, such as construction machinery (e.g. a cement mixer or bench-mounted circular saw), present a range of both mechanical and non-mechanical hazards.

### Mechanical and Non-Mechanical Hazards

The hazards of machinery can be divided into:

- **Mechanical hazards** – mainly from contact with or being caught by dangerous moving parts.
- **Non-mechanical hazards** – mainly from the power source or things emitted by the machine.

This follows BS EN ISO 12100:2010 *Safety of machinery*.

### Mechanical Hazards

The mechanical hazards of machinery are identified by reference to the **consequences** of contact or exposure (i.e. the injury causation mechanism) and can be further subdivided into the following classes:

- **Crushing** – the body is trapped between two moving parts or one moving part and a fixed object (e.g. a hydraulic lift collapses crushing a person underneath it).



Crushing – the person is crushed between the moving object and the wall

- **Shearing** – a part of the body (usually fingers) is trapped between two parts of the machine, one moving past the other with some speed. The effect is like a guillotine, shearing off the trapped body part.

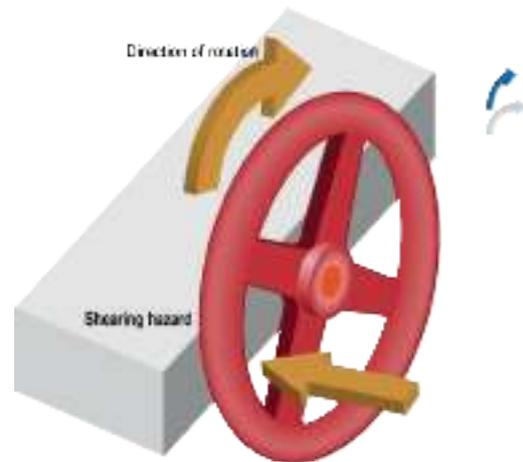

Shearing – a finger put through the spokes of this wheel will be sheared off

- **Cutting or severing** – contact is made with a moving sharp-edged part such as a blade (e.g. the blade of a bandsaw).

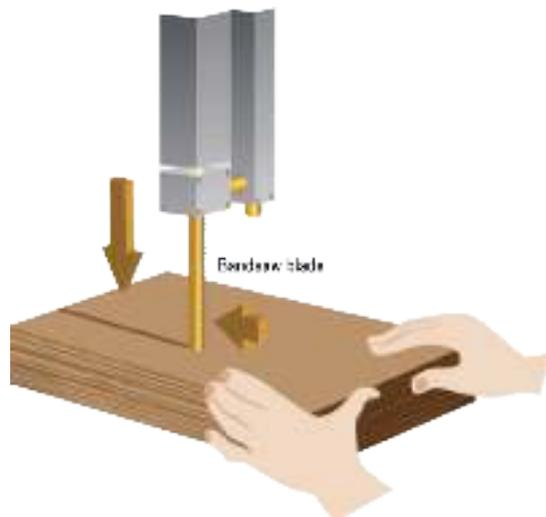

Cutting or severing – if the hands come into contact with the moving blade, severe laceration or amputation will occur

- **Entanglement** – loose items such as clothing or hair get caught on a rotating machine part and the person is wound up onto the machine.

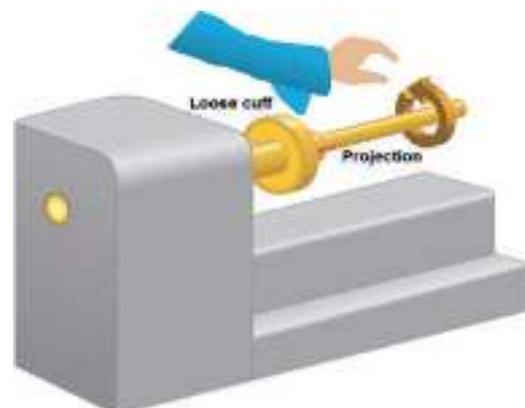

Entanglement – a loose cuff becomes entangled with the chuck of a lathe

- **Drawing in or trapping** – a part of the body is caught between two moving parts and drawn into the machine (e.g. at 'in-running nips' where two counter-rotating rollers meet).

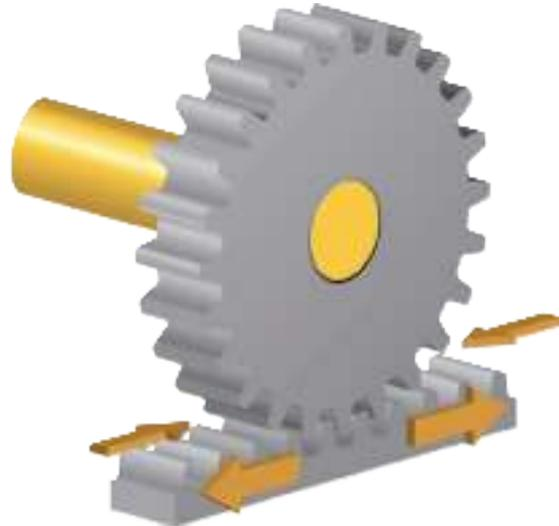

Drawing in or trapping – if the rollers are touched at the in-running nip point then the hand will be drawn in by the two rollers

- **Impact** – the body is struck by a powered part of a machine (this is similar to crushing, but there is no fixed structure to trap the person; the speed and weight of the object does the damage).



Impact – the person is struck hard by the heavy and fast-moving industrial robot

- **Stabbing or puncture** – sharp parts of the machine, or parts of material ejected from the machine, penetrate the body (e.g. swarf, sewing machine needle, abrasive wheel fragments, nails from a nail gun, etc.).



Stabbing or puncture – small fragments of the abrasive wheel are ejected at high speed and can cause penetration injury, particularly to the eyes

- **Friction or abrasion** – contact is made with a fast-moving surface which may be smooth (e.g. touching a spin dryer) or rough (e.g. touching a belt sander).

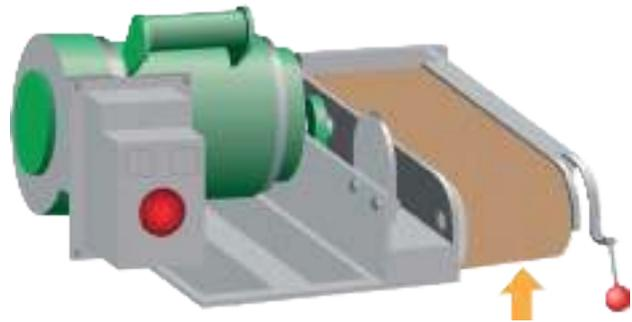

Friction or abrasion – if the belt is touched while in motion then abrasion occurs

- **High-pressure fluid injection** – fluid at very high pressure is ejected from the machine and penetrates the skin (e.g. hydraulic fluid escaping from a burst hydraulic hose).

## Non-Mechanical Hazards

The non-mechanical hazards of machinery are all of the **other hazards** that do not arise directly from contact with dangerous moving parts. They are mainly associated with the power source of the machine or are things that it emits. In other words, they are all the hazards that remain once the mechanical hazards have been listed.

### TOPIC FOCUS

The non-mechanical hazards of machinery are:

- Electricity.
- Noise.
- Vibration.
- Hazardous substances.
- Ionising radiation.
- Non-ionising radiation.
- Extreme temperatures.
- Ergonomics.
- Slips, trips and falls.
- Fire and explosion.

These hazards are covered in other Unit IG1 elements, so here just two issues are clarified:

- **Hazardous substances** are often contained or used by machinery as an integral part of the process (e.g. a metal-cutting lathe uses cutting fluid to cool and lubricate the cutting bit). In other instances, hazardous substances are produced as a by-product of machine operation (e.g. a robot welder produces welding fumes).
- **Ergonomic hazards** result from the interaction of the machine operator and the machine – from the posture that the operator has to adopt during machine use and the stresses put on the body. For example, a construction worker using a concrete breaker may have to support the weight (e.g. 8kg) of the breaker in order to cut a hole for a door lintel.

Specific examples of the mechanical and non-mechanical hazards of typical machines will be covered at the end of this element after the next section on control measures.

### STUDY QUESTIONS

4. Identify the non-mechanical hazards arising from the use of machinery.
5. Outline how drawing-in injuries are caused.

(Suggested Answers are at the end.)

## Control Measures for Machinery Hazards

### IN THIS SECTION...

- Guards and other protection methods have to be used to control the risks associated with all such types of machinery.
- Protection from machinery hazards can be achieved by using guards that physically enclose the hazard and prevent contact. Fixed guards are most effective at preventing contact, but interlocked guards, adjustable guards and self-adjusting guards may be required.
- If it is not possible to completely guard in a hazard then other forms of protection will have to be used, such as sensitive protective equipment; two-hand controls; protective appliances; emergency stops; PPE; or information, instruction, training and supervision.
- Guards and safety devices must: meet relevant standards, be strong and robust, be compatible with machine operation, not be easy to defeat, allow visibility and ventilation, take maintenance into account, and not increase overall risk.

### Machinery Safeguarding Methods

It may be possible to eliminate the risk created by a piece of machinery by getting rid of the machine that creates the risk. However, this is not an option in most circumstances.

It is also possible that the hazards associated with a piece of machinery can be eliminated by good design. This is the job of the manufacturer and statute law exists to ensure that this approach is taken. But even when this is done, hazards will still remain.

It is, therefore, essential that further safeguards are used to control the remaining hazards. The best approach is to create a safe machine using engineering controls (such as fixed guards). In some situations, it is not possible to guard in a machine hazard, so then other devices and appliances have to be applied.

Some hazards cannot be controlled by engineering means at all, so safety depends solely on operator behaviour. This is, of course, the least preferred option because operators are prone to human error and commit violations.

The hierarchy of control measures for dangerous moving parts of machinery is best understood by looking at a specific hierarchy created by the UK's **PUWER**. **PUWER** Regulation 11 sets out the methods by which this must be achieved, through provision of:

- Fixed, enclosed guards that encase or surround the dangerous part.
- Other guards and protection devices, such as interlocked guards, self-adjusting guards, adjustable guards, pressure mats, trip devices and two-hand controls.
- Protection appliances, such as jigs, holders and push-sticks.
- Information, instruction, training and supervision.

Each of these precautions has to be used where and to the extent that is **practicable**. 'Practicable' means that if it can be done (i.e. it is possible), then it must be done.



Guards reduce the risks from machinery hazards

Here, each of the safeguards will be looked at that might be used, in order of preference. Usually, a combination of the various safeguards is used to reduce risk to an acceptable level.

## Fixed Guards

A **fixed** guard is a physical barrier that prevents a person from coming into contact with dangerous moving parts. The guard may be shaped to fit the machine quite closely (enclosing guard) or it may be more like a fence around the machine (perimeter guard). It may have openings in it (e.g. to allow raw material to be fed into a machine), but these must be designed in such a way that it is not possible to reach in and contact dangerous parts (distance guard).

The basic principles of a fixed guard are that:

- It completely prevents access to dangerous parts.
- It is fixed in place.
- Fixings require a tool for removal – the guard must not be removable by finger force alone.

Fixed guards are often made of sheet metal. If ventilation (e.g. to prevent overheating of machine parts) or visibility into the machine is required, then a mesh guard or Perspex guard might be used instead. If a mesh guard is used, then care must be taken to ensure that the mesh size is not so large as to allow access to dangerous parts.

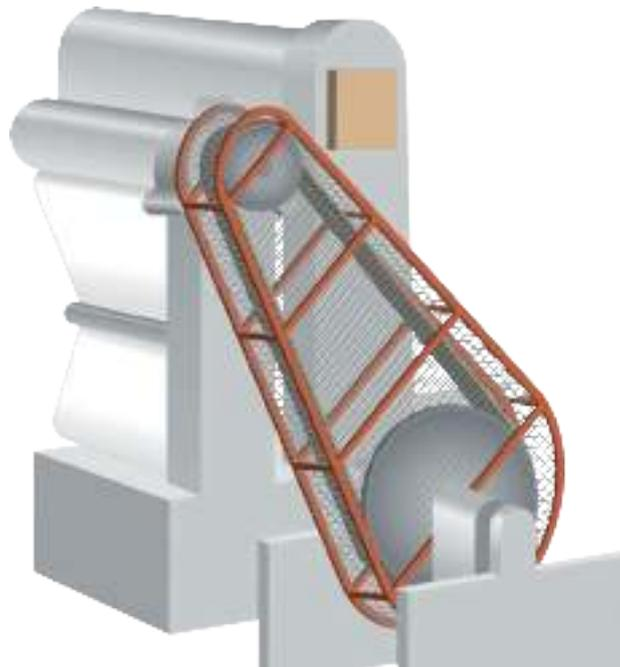

A fixed enclosed guard on a belt drive mechanism – this guard is made of mesh to allow ventilation and visibility

Fixed guards can also offer some protection against non-mechanical hazards, such as preventing access to electrical conductors; containing radiation sources; and preventing access to hot surfaces or hot parts, noise and also containments of dust, swarf or other hazardous materials ejected from the machine.

The main **disadvantage** of a fixed guard is also its main strength – it totally prevents easy access into the machine. There are many situations where easy access into a machine is necessary for machine operation, setting or cleaning. When routine access inside a guard is required, a fixed guard should not be used. If it is, then the operator is very likely to leave the guard off because it is interfering with machine operation.

## Interlocked Guards

An **interlocked** guard is designed to be removed or opened as a normal part of routine machine operation. When the guard is removed, a safety interlock system prevents machine operation. For example, a microwave oven has a hinged door on the front to allow easy access; this door is interlocked so that power to the microwave generator is shut off when it is open.

The basic principles of an interlocked guard are that:

- Power to the machine is disabled and the machine will not operate until the guard is in place.
- Either the guard is locked shut until it is safe for the guard to open, or the act of opening the guard stops the dangerous parts and disables power.

Many machines are fitted with interlocked doors which, when opened, bring the moving parts to an immediate stop (e.g. a photocopier). However, some machines cannot be stopped in this way and it is then preferable to use an interlocked guard that locks shut and can only be opened once the danger has passed (e.g. a domestic washing machine).

Interlocked guards:

- stop the machine immediately when the guard is opened; or
- will not allow the guard to be opened until the machine has fully stopped; and
- will not allow the machine to restart until the guard has been properly closed.

The main **limitation** of an interlocked guard is that it is possible to bypass the system so that the machine can be operated with the guard open. With simple interlock systems this is easily done, but even complex interlock systems can be defeated by a determined person. For example, a person may gain access to the inside of a machine enclosure during operation by climbing over the guard, or by the equipment being restarted by a second operator once the first person is inside the enclosure.

It is, therefore, important that:

- The appropriate type of interlock system is fitted to the machine.
- Strict rules are imposed about safe use of interlocking guards.
- Regular maintenance is carried out.

## Adjustable and Self-Adjusting Guards

Adjustable and self-adjusting guards are used when it is not possible to completely prevent access to dangerous parts. They are commonly used to safeguard woodworking and metalworking machinery where a workpiece has to be fed into the machine or manipulated during machine use.

An **adjustable guard** can be set to a range of positions by the operator, depending on the nature of the workpiece and the operation being carried out. For example, the top guard on a bench-mounted circular saw (table saw) can be set at a range of heights depending on the size of wood being cut.

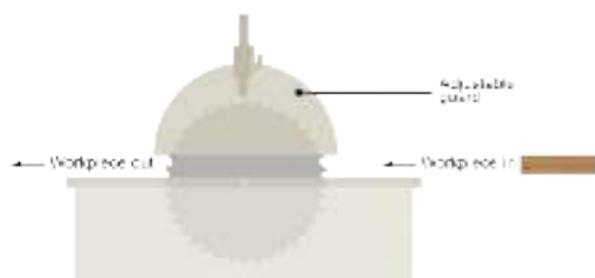

Adjustable guard over blade of bench-mounted circular saw; the guard covers most of the blade but a section remains exposed so that wood can be fed through

A **self-adjusting guard** does the same thing but is spring-loaded or linked to other machine parts. As the machine operates, the guard adjusts automatically to fit the workpiece. It does not require the operator to set it to the right position.

Main **limitations** with adjustable and self-adjusting guards are that they:

- Do not completely prevent access to dangerous parts.
- Are very easy to defeat.
- Rely entirely on operator competence.

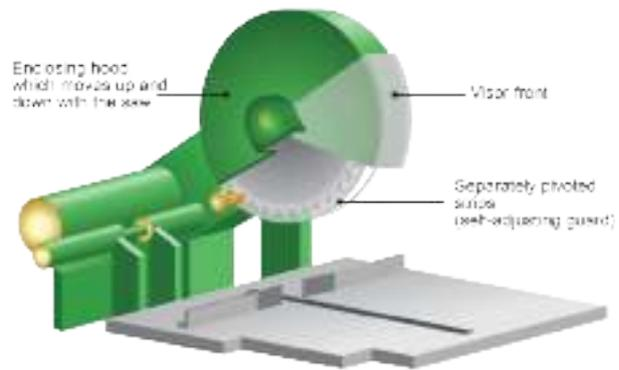

Self-adjusting guard on a crosscut mitre saw; as the saw moves down, the guard retracts to expose the blade

## Sensitive Protective Equipment (Trip Devices)

The terms 'sensitive protective equipment' or 'trip devices' cover a range of **protective devices** that do not put a physical barrier between the operator and the dangerous part of machinery. Instead, some form of sensor is used to detect the presence of the operator and stop the machine. The use of sensitive protective equipment is intended to minimise the severity of an injury and is often an additional control measure. For example, a pressure safety mat could be used inside an industrial robot enclosure combination with an interlocked access gate in the perimeter guard. This ensures that if an operator does gain access by climbing over a perimeter guard or is locked inside the enclosure by a colleague, then the pressure safety mat will be activated and the robot will not operate.

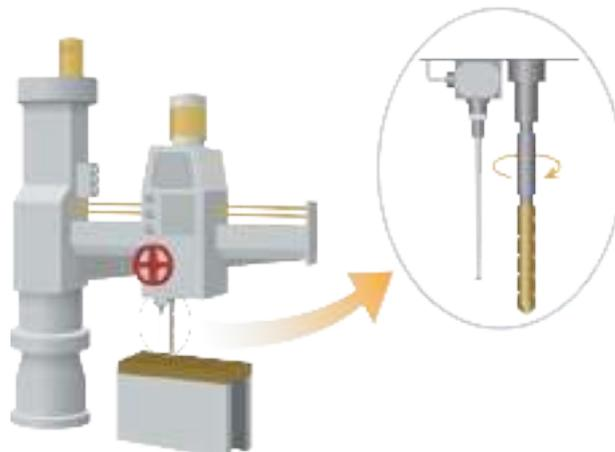

Trip bar fitted to a drilling machine – if the bar is hit, the drill emergency stops; note that the bar does not prevent entanglement but simply reduces the severity of injury

There are different types of sensitive protective equipment:

- **Pressure safety mats** – mats placed on the floor around an item of machinery such as an industrial robot. If a person stands on the mat, their weight activates the trip and the robot stops moving.
- **Trip bars** – wands or rods placed close to dangerous parts which, when touched, will stop machine movement.
- **Photoelectric devices** – devices which shine beams of light across an access point. If the beams are broken then the machine is stopped.



A photoelectric device fitted to a press brake; the device forms a curtain of beams across the front of the machine.

Based on original source: L22 *Safe use of work equipment* (4th ed.) HSE, 2014  
([www.hse.gov.uk/pubns/priced/l22.pdf](http://www.hse.gov.uk/pubns/priced/l22.pdf))

The main **limitations** of sensitive protective equipment are that they:

- Do not provide a physical barrier to prevent access.
- Can be overridden (e.g. using platforms to span a pressure mat).
- May not operate fast enough to prevent harm (but may reduce the severity) (e.g. the person may still make contact with the machine before it stops, but it will be slowing down).
- May be overly sensitive, leading to frequent trips which will encourage the operator to bypass or disable them.
- Are more complicated than simple physical guards and may therefore fail more frequently, which encourages misuse.

## Two-Hand Controls

These are a way of protecting the machine operator's hands where operation of the machine can only be achieved when two 'start' buttons are pressed at the same time. They are often used when routine machine use requires the operator to put their hands inside or under a machine where they are at risk from machine operation.

The idea is that the machine will only operate when the operator has both hands on the controls. There are important principles of two-hand controls:

- Controls must be more than one hand span apart (to prevent one-handed operation).
- Controls have to be activated simultaneously (to prevent the operator jamming one button down permanently).
- Releasing the controls must stop the machine immediately.

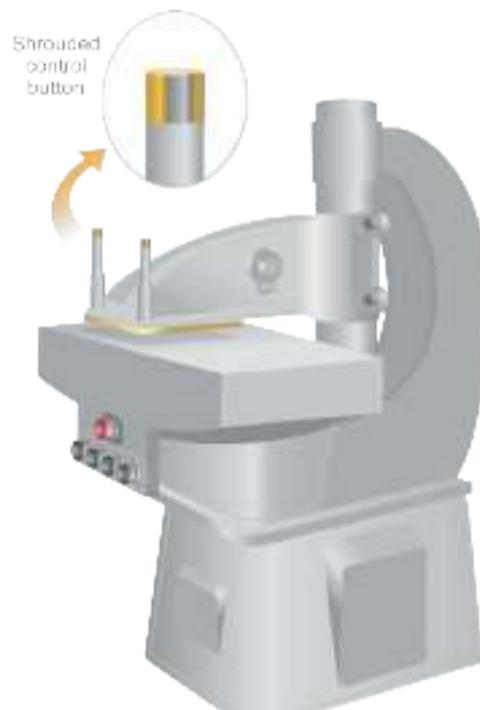

Two-hand controls on a click press; the operator is at risk of a crushing injury if the press operates when their hand is between the top and bottom plates

The main **limitations** of two-hand controls are that they:

- Do not protect other parts of the body.
- Are relatively easy for two operators working together to bypass the system.

## Hold-to-Run Controls

Hold-to-run controls, as they suggest, require the operator to hold the control at all times while the equipment or machine is in operation. Releasing the control for whatever reason will disconnect power from the machine and it will cease to function. On some equipment, this may be in the form of either a handle or foot pedal, and is often referred to as a 'dead-man's handle'.

Important principles of hold-to-run controls are:

- The handle (or pedal) must be held (or beneath the foot) at all times while the machine operates.
- Releasing the control must stop the machine immediately.

The main **limitations** of hold-to-run controls are that they:

- Do not protect any parts of the operator's body.
- Can be held or operated by a person other than the operator.
- Can be easily defeated by an operator.

## Emergency Stop Controls

Emergency stops were described earlier in this element.

They can be buttons or pull cords and should be positioned at easily reached positions on the machine and associated control panels.

The key principles of emergency stops are that:

- They should bring the machine to a safe stop as quickly as possible.
- They should latch or lock in so that the machine can only be restarted by going to the location of the button to reset it.
- The release of the button should not restart the machine.

Emergency stop buttons should **never** be used as a substitute for machine guarding or protection devices. They are intended to provide an additional level of protection in case other safeguards fail.

The main **limitations** of emergency stops are that:

- They are only used once danger has been sensed by the operator and by then it may be too late.
- Despite good design, a person trapped by a machine may not be able to reach the emergency stop.
- It may not be possible to emergency brake the machine quickly enough to prevent injury.

## Protective Appliances

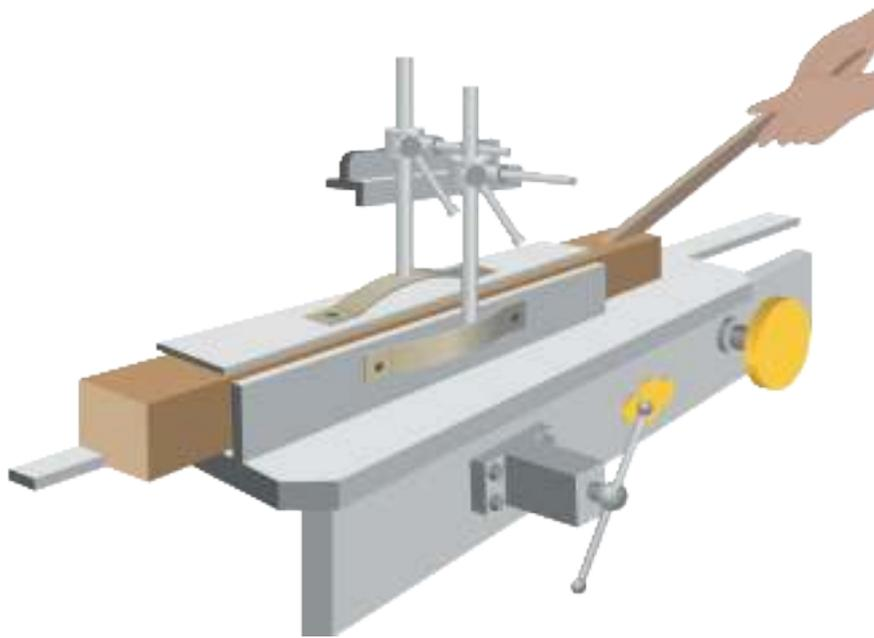

A push-stick

Based on original source: L22 *Safe use of work equipment* (4th ed.) HSE, 2014  
([www.hse.gov.uk/pubns/priced/l22.pdf](http://www.hse.gov.uk/pubns/priced/l22.pdf))

Protective appliances are pieces of equipment that allow an operator to keep their hands away from dangerous parts. They include clamps, jigs and push-sticks. Clamps and jigs are designed to hold the workpiece in place; a push-stick is used to push a workpiece through a woodworking machine. The push-stick is simply a piece of wood with a V-shaped notch cut in one end.

## Personal Protective Equipment

Personal Protective Equipment (PPE) should only be used as a last resort after other, more reliable, protection options have been exhausted.

Inevitably, though, some of the hazards associated with machinery cannot be designed out or safeguarded by any other means; in these instances PPE becomes appropriate.

A wide range of PPE is available to protect machine operators from one or more hazards associated with the machine that they are operating (e.g. respiratory protective equipment may be used to prevent inhalation of hazardous fumes, dust or mist emitted by the machine).

One item of PPE commonly used by machine operators is eye protection. Safety spectacles, goggles or face visors may be used to prevent impact injury to the eye. Such eye protection must always be selected with reference to the relevant standards.

The general limitations of PPE have been highlighted in Element 3; however, one particular issue worth noting here is that sometimes the use of gloves is inappropriate because it increases the risk of entanglement or drawing in, and may increase the severity of injury that results.



Worker wearing PPE

## Information, Instruction, Training and Supervision

Appropriate information, instruction, training and supervision must be provided to machine operators. The question of how much is appropriate can be answered by considering the level of risk associated with the machinery and by reference to legal standards, ACoPs and guidance.

In particular, information, instruction, training and supervision become important where the level of risk is high and it has not been possible to use other controls to safeguard the machinery. So, for example, very little information, instruction, training and supervision is needed when introducing a document shredder into an office because the machine will be very well safeguarded already; simply asking users to read the instruction manual and then checking to ensure that they do not misuse the machine should be sufficient. With an item of woodworking machinery, the risk of serious injury and safe use of the machinery is less reliant on fixed and interlocked guards and far more reliant on safe operating procedures; so far more information, instruction, training and supervision has to be provided.

## Specific Machinery Examples – Hazards and Control Measures

The following examples illustrate the hazards and control methods associated with typical machines found in different types of workplaces.

### Manufacturing and Maintenance Machinery

#### Bench-Top Grinder

- **Hazards:**
  - Abrasion on contact with rotating abrasive wheel.
  - Drawing in at nip point between wheel and tool rest.
  - Puncture by ejected parts of the wheel during normal use or if it bursts.
  - Entanglement with the spindle on which the wheel is mounted.
  - Electricity.
  - Hot parts caused by friction (especially the workpiece being ground).
  - Health hazard from dust.
  - Noise and vibration.
- **Protection:**
  - Fixed, enclosing guards around the motor and part of the abrasive wheel.
  - Adjustable polycarbonate eye guards over the exposed part of the wheel.
  - Tool rest adjusted to minimise the nip point between the rest and the wheel.
  - Use and setting restricted to trained operators only.
  - Eye protection (impact-resistant).
  - Hearing protection may be necessary.
  - Routine inspection and portable appliance testing.

## Pedestal Drill

- **Hazards:**

- Entanglement with the rotating drill bit or chuck.
- Stabbing or puncture by the drill bit during normal use or if the bit breaks.
- Puncture by swarf ejected during metal cutting.
- Impact if struck by the workpiece if the bit jams and the workpiece rotates.
- Drawing in at nip points between motor and drive belts.
- Electricity.
- Noise.
- Hot parts (especially the drill bit).
- Health hazard from cutting fluid (e.g. dermatitis).

- **Protection:**

- Fixed guards over motor and drive mechanisms.
- Adjustable (possibly interlocked) guard over the chuck and drill bit.
- Clamp to secure the workpiece to the base.
- Eye protection (impact-resistant).
- Hearing protection may be necessary.
- Routine inspection and portable appliance testing.
- Use restricted to trained operators only.



Pedestal drill

## Agricultural and Horticultural Machinery

### Cylinder Mower (Petrol-Driven, Ride-On Type)

- **Hazards:**

- Cutting on contact with moving blades.
- Impact or crushing if struck by the mower.
- Entanglement with various rotating parts.
- Drawing in at various nip points.
- Noise.
- Vibration.
- Fire and explosion from petrol (fuel).
- Health hazard from sensitisation to grass sap, pollen, etc.

- **Protection:**

- Fixed guards over the drive mechanism.
- Safety switch under the seat to ensure that the driver is in the seat before the machine will operate.

- Use restricted to trained operators only.
- Hearing protection.
- Refuelling carried out in a well-ventilated area.
- Job rotation may be necessary to limit vibration exposure.
- Use restricted for workers with sensitisation.

### Strimmer or Brush Cutter (Petrol-Driven)

- **Hazards:**
  - Cutting on contact with the moving cutting head.
  - Entanglement with the rotating cutting head.
  - Puncture by objects ejected by the cutting head (e.g. stones).
  - Noise.
  - Vibration (into hands).
  - Fire and explosion from petrol (fuel).
  - Ergonomic from repetitive movement, such as twisting or carrying.
  - Health hazards from sensitisation to grass sap, pollen, etc.
  - Health hazard from ejected/atomised animal faeces.
- **Protection:**
  - Fixed enclosing guards over motor and drive mechanisms.
  - Partial side guards fitted around the cutter head.
  - Safety interlocked throttle trigger to prevent accidental operation of the throttle.
  - Face and eye protection (impact-resistant).
  - Hearing protection.
  - Stout gloves, boots (steel-toe cap), trousers and shirt.
  - Job rotation may be necessary to limit vibration exposure.
  - Harness to support and balance weight of machine.
  - Refuelling carried out in well-ventilated area.
  - Use restricted to trained operators only.
  - Use restricted for workers with sensitisation.

### Chainsaw (Petrol-Driven)

- **Hazards:**
  - Cutting on contact with the moving blade.
  - Entanglement with the moving blade.
  - Drawing in at nip point between the blade and casing.
  - Puncture by ejected parts (especially broken blade fragments).
  - Noise.

- Vibration (into hands).
- Fire and explosion from petrol (fuel).
- Ergonomic from handling.
- Health hazards from dust and sap.
- **Protection:**
  - Appropriate PPE (see Topic Focus box).
  - Fixed enclosing guards over motor and drive mechanisms.
  - Hand guard for front-hand grip.
  - Chain brake to stop the chain in the event of kick-back.
  - Safety interlocked throttle trigger to prevent accidental operation of the throttle.
  - Job rotation may be necessary to limit vibration exposure.
  - Refuelling carried out in a well-ventilated area.
  - Use restricted to trained operators only.



Worker wearing appropriate PPE while using a chainsaw

## TOPIC FOCUS

PPE when using a chainsaw includes:

- Face (visor) and eye protection (impact-resistant).
- Hearing protection.
- Head protection (hard hat) – may be necessary.
- Stout gloves.
- Boots with good grip and steel-toe caps.
- Cut-resistant trousers or chaps.
- Stout shirt.

## Retail Machinery

### Compactor

- **Hazards:**
  - Crushing if inside during operation.
  - Shearing between moving arms during operation.
  - Crushing or impact by ejected bale or container lorry.
  - Electricity.
  - High-pressure fluid ejection from the hydraulic system.
  - Ergonomic from handling material during loading.



- **Protection:**
  - Fixed perimeter guard around the loading area and mechanism.
  - Interlocked guard to allow access to the loading area.
  - Routine inspection and portable appliance testing.
  - Use restricted to trained operators only.

## Construction Machinery

### Cement Mixer:

- **Hazards:**
  - Entanglement with the rotating drum or drive motor.
  - Drawing in at nip point between the motor and drive mechanism.
  - Crushing between the drum and drum stop when tipping.
  - Friction or abrasion on contact with the moving drum.
  - Electricity.
  - Ergonomic from handling during loading.
  - Health hazard from cement dust inhalation and contact with wet cement (corrosive).
- **Protection:**
  - Fixed guards to motor and drive mechanisms.
  - Routine inspection and portable appliance testing.
  - Use restricted to trained operators only.
  - Hand protection and eye protection (splash-resistant).



### Bench-Mounted Circular Saw (Table Saw)

- **Hazards:**
  - Cutting on contact with the blade.
  - Entanglement with the drive motor.
  - Drawing in at nip points between the motor and drive belt.
  - Ejection of the workpiece during cutting.
  - Electricity.
  - Noise and vibration.
  - Health hazard from inhalation of wood dust.
- **Protection:**
  - Fixed guard fitted to the motor and bottom of the cutting blade.
  - Adjustable top guard fitted above the blade.
  - Riving knife fitted behind the blade (this prevents the timber from pinching shut on the saw blade after it has been cut, which can lead to the timber being kicked back toward the operator).
  - Hearing protection.

- Eye protection (impact-resistant).
- Extraction ventilation or respirator may be necessary.
- Routine inspection and portable appliance testing.
- Use restricted to trained operators only.

## Requirements for Guards and Safety Devices

Guards and safety devices must be **suitable**. If they are not, they will not fulfil their function, the machine may not operate correctly, or the operator may come under pressure to remove or defeat them.

### TOPIC FOCUS

Basic characteristics of a guard or safety device include the following:

- It meets relevant standards – by preventing contact with dangerous parts.
- It is strong and robust – to withstand the forces it may be subjected to.
- It is compatible – it must not interfere with the machine operation or the process.
- It is not easy to defeat or bypass.
- Vision – it must not interfere with any need to see in.
- Ventilation – it must not interfere with any ventilation required.
- Ease of maintenance – it should be easy to maintain and maintained in good condition.
- Removal for maintenance – ideally, the guard should not have to be removed to allow maintenance on the machine to take place.
- It does not increase overall risk.

### Legal Standards

- ILO C155 – Occupational Safety and Health Convention, 1981 (No. 155).
- ILO R164 – Occupational Safety and Health Recommendation, 1981 (No. 164).
- ILO C119 – Guarding of Machinery Convention, 1963 (No. 119).
- ILO R118 – Guarding of Machinery Recommendation, 1963 (No. 118) (to be revised).

**STUDY QUESTIONS**

6. Identify the hierarchy of protective measures.
7. Describe the principles of an interlocking guard system.
8. Outline what a trip device is.
9. Identify the limitations of adjustable guards.
10. Outline the meaning of the phrase 'protective appliance'.
11. Identify when operators are required to be trained in the use of safety equipment.
12. Identify how two-handed controls might be overridden.
13. Identify five requirements for any guarding system.
14. Identify the hazards that arise from the use of the following machines:
  - (a) Bench-top grinder.
  - (b) Chainsaw.
  - (c) Bench-mounted saw (table saw).
15. Identify the PPE that should be worn when using a chainsaw.

(Suggested Answers are at the end.)



## Summary

---

This element has dealt with some of the hazards and controls relevant to work equipment.

In particular, this element has:

- Described some of the basic management issues that must be considered when introducing work equipment, such as:
  - Suitability for task and environment.
  - Restriction of use to competent operators.
  - Information, instruction and training.
  - Inspection and maintenance requirements.
  - Marking and positioning of controls.
  - Stability, lighting and space requirements.
  - Operator behaviour.
- Outlined the hazards and precautions associated with simple hand tools, such as hammers and chisels.
- Outlined the hazards and precautions associated with portable power tools, such as a portable electric drill or disc cutter.
- Explained the mechanical hazards of machinery such as: crushing, shearing, cutting or severing, entanglement, drawing in or trapping, impact, stabbing or puncture, friction or abrasion, and high-pressure fluid injection.
- Identified the non-mechanical hazards of machinery as: electricity; noise; vibration; hazardous substances; radiation (ionising and non-ionising); extreme temperatures; ergonomics; slips, trips and falls; and fire and explosion.
- Explained the basic characteristics of fixed guards, adjustable and self-adjusting guards, and interlocked guards as well as the characteristics of trip devices, two-hand controls, protective appliances and emergency stops.
- Outlined the basic requirements of guards and safety devices where they: must meet relevant standards, be strong and robust, be compatible with machine operation, not be easy to defeat, allow visibility and ventilation, take maintenance into account, and not increase overall risk.
- Described the hazards associated with bench-top grinders, pedestal drills, cylinder mowers, strimmers, chainsaws, compactors, cement mixers and bench-mounted circular saws.
- Identified the types of guard and other protection measures to ensure safety in the use of bench-top grinders, pedestal drills, cylinder mowers, strimmers, chainsaws, compactors, cement mixers and bench-mounted circular saws.

# Practical Assessment Guidance

## Part 3 – Three Priority Actions



In the Practical Assessment Guidance at the end of the last element, we finished looking at risk assessment (Part 2 of the form) that you are required to complete.

In the next part of the guidance, we will look at Part 3 of the assessment which requires you to pick three actions for urgent attention and to justify your choices.



### Part 3: Prioritise three actions and justification for the selection

You must pick the three highest priority/most urgent actions and justify your choice. Your justification must include moral, legal and financial arguments (300 to 700 words); consideration of likelihood and probable severity of injury, ill-health and/or harm (150 to 250 words); Description of how effective each action is likely to be in controlling the risk (250 to 350 words).

Specimen

LABORATORY NUMBER

LABORATORY NAME

Page 5 of 6

**Note:** These forms are for reference purposes only. Please visit the NEBOSH website to obtain the official forms to submit your assessment.

The penultimate step in completing the practical assessment is to complete Part 3 of the assessment form.

You must pick what you think are the three most urgent or highest priority actions from your Part 2 risk assessment form. You must then justify your three choices by explaining, in detail, the:

- Moral, legal and financial reasons for taking these three actions.
- Current risk level presented by the relevant hazards as they are currently controlled (with reference to both the likelihood and severity of outcome, and the foreseeable injury or ill-health effects).
- Effectiveness of each proposed action in controlling the risk with some justification for the timescale allocated.

Your first task is to select the three most urgent/highest priority actions. All three actions must come from column 4 in Part 2 of the risk assessment form: 'What further controls/actions are required?'. They can come from three completely separate hazards/hazard categories, all from the same hazard/hazard category, or two from one hazard/hazard category and one from another. However, it is probably a good idea to pick actions from three different hazards, even if those hazards all come from the same hazard category (i.e. actions that come from three different rows of the risk assessment form).

The key thing is that the examiner should be able to see that the three actions picked look like they are the most urgent/highest priority of all of the actions listed in column 4 of the risk assessment form. So pick actions that will have the biggest impact on the most poorly controlled significant risks. Do not pick actions that address low risk/trivial risk hazards. Do not pick actions that address a risk that is already well controlled and do not pick actions that will not make very much difference to the current risk level.

Once you have picked the top three actions, you can then fill in the Part 3 of the form.

- Start by telling the examiner which three actions you have picked as urgent. You could do this by copying each specific action from column 4 of the risk assessment form and pasting it as a bullet point in the Part 3 box. It is a good idea to indicate which hazard category and hazard each action relates to (column one of the risk assessment form) so that the examiner can easily find each action on the risk assessment form.

You must then justify your three choices by clearly explaining the moral, legal and financial reasons for taking the actions required. You must make use of all three arguments in your justification. Do not skip one even if it seems obvious or irrelevant. You might find it useful to refer back to your Unit IG1 Element 1 study text for some ideas on this justification.

Importantly, when you are making your legal arguments, you must refer to the specific ILO Convention, Recommendation and/or Code of Practice that is relevant to the hazard category/hazard in question. Try to be as specific as possible and refer to the particular requirement that is relevant. So state what the specific requirement is for the examiner if you can, not just the overall name of the standard and a date. Make sure that the standard that you use is the relevant one, and that you get the title and date right. Check this by reference to authoritative sources (such as the ILO website) and do not simply rely on your study text (which might go out of date).

Parts of the justification can be written as they apply to all three actions collectively (for example, the moral justification), but other parts will have to be written as they apply to each of the three risks independently (for example, different sets of regulations will apply to three different actions that relate to three different hazard categories).

The key issue is that the examiner must see that you have a good technical grasp of the moral, legal and financial arguments that relate to the specific hazards in question.

NEBOSH indicates that the word count for this part of the justification should be 500–700 words.

- The next step in your justification is to explain the risk that is created by each hazard as it is currently controlled. You must explain the likelihood and severity for each of the relevant hazards. You must, therefore, explain the number of workers exposed to each hazard, the duration and frequency of exposure and the circumstances under which they might be exposed. You must also explain the foreseeable harm that each hazard might cause, such as the range of possible physical injuries and/or ill-health effects.

The key issue is that the examiner must see that you understand the two key factors – likelihood and severity – that combine to give the degree of risk.

NEBOSH indicates that the word count on this part of the justification should be 150–250 words.

- The final part of your justification requires you to explain how effective each action will be in controlling risk. You must explain the likely impact of each action, how effective you think it will be in reducing risk and why you have allocated the timescale that you have.

You will probably need to do this for each action independently. If an action will make a difference for just a few key exposed workers, then say so. If it will make a difference for everyone who works on site, then say so. If it might work really well but might only be partially effective because of poor uptake rates or rule compliance issues, then say so. If the timescale is challenging but the risk is very high and therefore it is essential that this challenging timescale is met, then say so.

The key issue is that the examiner must see that you are able to make a practical and realistic appraisal of the likely effectiveness of your proposed actions.

NEBOSH indicates that the word count on this part of the justification should be 250–350 words.

When you finish writing your justification in Part 3, go back and check that you have addressed all of the issues indicated in italics at the top of the form.

The final step of practical assessment, where you must indicate how you will review, communicate and follow up the risk assessment, will be dealt with at the end of Element 10.



## Learning Objectives

Once you've studied this element, you should be able to:

- 1 Describe the principles of fire initiation, classification and spread.
- 2 Describe the basic principles of fire prevention and the prevention of fire spread in buildings.
- 3 Describe the appropriate fire alarm system and fire-fighting arrangements for a simple workplace.
- 4 Describe the factors which should be considered when implementing a successful fire evacuation of a workplace.

<b>Fire Initiation, Classification and Spread</b>	<b>10-3</b>
Principles of Fire	10-3
Classification of Fires	10-3
Principles of Heat Transmission and Fire Spread	10-4
Common Causes and Consequences of Fires in Workplaces	10-5
<b>Preventing Fire and Fire Spread</b>	<b>10-7</b>
Control Measures to Minimise the Risk of Fire in a Workplace	10-7
Storage of Flammable Liquids	10-11
Structural Measures for Preventing the Spread of Fire and Smoke	10-13
<b>Fire Alarms and Fire-Fighting</b>	<b>10-16</b>
Fire Detection and Alarm Systems	10-16
Portable Fire-Fighting Equipment	10-17
Access for Fire and Rescue Services	10-20
<b>Fire Evacuation</b>	<b>10-21</b>
Means of Escape	10-21
Emergency Evacuation Procedures	10-24
<b>Summary</b>	<b>10-29</b>
<b>Practical Assessment Guidance</b>	<b>10-30</b>

















## Storage of Flammable Liquids

Many work activities require a limited quantity of flammable liquids to be held in the workplace, and these may be stored in suitable cabinets or bins of fire-resisting construction that are designed to retain spills.

### DEFINITION

#### FLASH POINT

The flash point of a liquid is the lowest temperature at which flammable vapour will form at the surface that can be ignited by the application of an external ignition source. Sustained combustion does not continue (the vapour burns briefly and then goes out).

The lower the flash point, the lower the temperature at which it is possible to ignite the liquid.

All **flammable liquids** have a low 'flash point' (<60°C) and are therefore relatively easily ignited with an ignition source (such as a match) at normal room temperature.

Some of these liquids have very low flash points and so are labelled as 'highly flammable' or 'extremely flammable':

- Category 3 '**flammable liquids**' have a relatively low flash point (between 23°C and 60°C).
- Category 2 '**highly flammable liquids**' have a low flash point (<23°C) and boiling point >35°C.
- Category 1 '**extremely flammable liquids**' have a low flash point (<23°C) and boiling point <35°C.

(Note: the above classification and labelling is according to the UN's Globally Harmonized System and the **European Regulation (EC) No. 1272/2008 on Classification, Labelling and Packaging of Substances and Mixtures (CLP Regulation)**.)

Petrol (gasoline) is a common example of a highly flammable liquid. Quite simply, the lower the flash point, the more dangerous the substance, so it is essential that flammable liquids are used and stored safely. Because of the fire and explosion risk presented by flammable liquids, they are subject to additional legal control. In the EU, they are subject to the ATEX which in the UK means that they are classified as 'dangerous substances' under **DSEAR**. These Regulations sit alongside the **Regulatory Reform (Fire Safety) Order 2005 (RRFSO)** and impose a stricter regulatory regime on dangerous substances where significant fire and explosion risk exists.

Employers should determine the extent of the flammable atmosphere that could result from leaks and ensure all potential ignition sources are excluded.

Cabinets and bins storing flammable substances should be located in well-ventilated areas that are:

- away from the immediate processing area where possible; and
- do not jeopardise the means of escape from the area.

Flammable liquids should be stored separately from other dangerous substances that may increase the risk of fire or compromise the integrity of the container, such as oxidisers.

The recommended maximum quantities that may be stored in cabinets and bins are:

- no more than 50 litres for extremely or highly flammable liquids; and
- no more than 250 litres for other flammable liquids.

### TOPIC FOCUS

**Safe use** of flammable liquids includes the following:

- Use the minimum volume of liquid required.
- Store the liquid in a properly labelled container.
- Ideally, ensure that the container is metal with a self-closing lid.
- Use a metal tray to catch spills and have absorbent materials available.
- Use away from heat and ignition sources.
- Ensure that workspace is well-ventilated.
- Return containers to safe storage after use.

**Safe storage** of small volumes (extremely/highly flammable (<50 litres) or flammable (<250 litres)) in workrooms includes:

- Storing minimal volumes only.
- Using closed containers.
- Storing in a purpose-built flammables cabinet. A flammables cabinet should:
  - Be fire-resistant (metal).
  - Have lockable doors and fire-resistant hinges and fastenings.
  - Be clearly signed.
  - Have a built-in catch tray.
- Storing away from potential ignition sources.

**Safe storage** of larger volumes of flammable liquid involves:

- Storing flammables in a purpose-built, single-storey flammables store, with segregated storage if necessary.
- The store being built of non-combustible materials.
- The store having a lightweight roof for explosion relief.
- Ideally, the store being built outdoors away from other buildings or having firewall protection.
- The store being suitably fenced in a secure area.
- All electrical systems being intrinsically safe.
- All other ignition sources being eliminated.
- The store being well-ventilated at high and low levels.
- All access doors being lockable with a sill to contain spillages.
- Having adequate fire-fighting equipment.
- Having suitable fire safety signs.
- Making regular checks for security, secure and safe storage, leaks of liquids, etc.
- Having clear, safe access for the fire service together with adequate means of escape.

## Structural Measures for Preventing the Spread of Fire and Smoke

### Scenario

If a fire starts on the ground floor of a large, open-plan, multi-storey building that has open stairwells, **convection** will drive the hot smoke from the fire upwards. The smoke will fill the ground floor of the building and then rise up each of the open stairwells. Each stairwell will, in effect, become a chimney. The hot smoke will then fill the upper storeys of the building. The fire will not be contained and will spread through the building. The building will be destroyed or suffer severe damage. Any people in the building, especially in the upper storeys, will become trapped and die as a result of fire and smoke inhalation because they will not have time to escape and their escape route (the stairwells) will be full of smoke and flames.

### Compartmentation

This is obviously not a desirable scenario. If fire prevention does not work and a fire does start in a building, then it should be contained and prevented from spreading. This can be done by designing the building so that it is divided up into separate **compartments**, each surrounded by fire-resistant materials that can resist the spread of smoke and flames.

This **compartmentation** is done at the initial design and build stage but may also have to be done if a building is changed or modified. Local **building regulations** play a significant part in applying high standards of compartmentation to workplaces. This is why it is necessary to obtain building regulation approval for new buildings and some alterations to existing premises.

If the multi-storey building in our scenario is compartmentalised, when the fire starts on the ground floor it will be contained in one part of the building. This will give time for the fire to be detected, the alarm raised and the building evacuated. Containment may result in the fire dying down or even going out as a result of oxygen starvation. If this does not happen, then the fire will eventually break through the containment, but this will take time.

Constructing walls, floors and ceilings out of fire-resistant materials and ensuring that the building is broken up into appropriate compartments is only fully effective if any openings in the compartment walls are sealed.

Since people have to move through buildings, doors must be fitted to openings. These doors must be built to withstand the spread of smoke and flames. Such doors are known as **fire-resisting doors (fire doors)**.

Typical characteristics of a fire door include being:

- Rated to withstand fire for a minimum period of time (e.g. 30 minutes).
- Fitted with:
  - A self-closing device.
  - An intumescent strip.
  - A cold smoke seal.
  - A vision panel of fire-resistant glass.
- Clearly labelled (e.g. 'Fire Door – Keep Shut').

## DEFINITIONS

### INTUMESCENT STRIP

A strip built into the edge of a fire door that expands when it gets hot ( $>200^{\circ}\text{C}$ ), sealing the gap between the door and the door frame.

### COLD SMOKE SEAL

A plastic or foam strip that seals the gap between the door and frame at all times to prevent the spread of smoke.

Note that these are typical characteristics of fire doors and the actual specification will vary according to need.

Higher-specification fire doors may be needed to:

- Contain fire within compartments that contain greater fire risk (e.g. a flammables store room).
- Keep fire out of compartments that contain fire-sensitive contents (e.g. an IT server room).

Most fire doors are fitted with a self-closing device that pulls the door shut once a person has walked through it. Some fire doors are fitted with electromagnetic openers that keep the fire door open at all times. If the fire alarm activates or the electrical supply to the opener is interrupted, then the door is released and closes. This type of door is common in corridors with heavy pedestrian traffic where a normal fire door would be an obstruction.

## Properties of Common Building Materials

Fire affects different building materials in different ways. The use of building materials, therefore, has to be tightly controlled to ensure that appropriate materials are used in a structure. For example, fire compartments must be robust enough to withstand the spread of fire for their design time, and structural elements in a building should not fail quickly when they are heated in a fire. Again, building regulations contain many requirements that relate directly to this fire safety issue:

- **Concrete** – usually very resistant to fire and does not collapse catastrophically. It may ‘spall’ (throw off small chunks).
- **Steel** – severely affected by high temperatures. Expansion may occur, pushing structural elements apart. Steel may also twist and warp; it can lead to sudden catastrophic building collapse.
- **Brick** – usually very resistant to fire (bricks are made by exposure to very high temperatures in a kiln). They may ‘spall’.
- **Timber** – thin timber, such as floor boards, will burn, but thick timber, such as structural beams, may not fully burn in a building fire (a layer on the outside of the timber will char and protect the inner core). Thick timber is unlikely to fail suddenly, but will do so slowly.

To overcome the problems associated with using steel as a structural material, it is usually encased in concrete or coated with a fire-retardant foam or paint (intumescent paint) that insulates it from excessive heat.

Other materials can make a difference to fire resistance and the behaviour of a fire in a building, for example:

- **Insulation** (e.g. wall insulation) can be combustible so fire-retardant versions must be used.
- **Wall coverings** (e.g. paint and wallpaper) can make a difference to the way fire spreads across surfaces, so should also be closely controlled.

## Protection of Openings and Voids

Fire doors are used to ensure that door openings are protected in the event of fire. However, buildings, and the fire compartments that they are made up of, will inevitably have numerous voids and openings running through them, such as lift shafts, service conduits, air-handling ducts, voids between floors, roof voids, etc. and all of these need to be protected to ensure that smoke and flames cannot easily travel from one compartment to another. This protection can be done in many different ways (e.g. a self-closing shutter held open by a fusible link (a piece of soft metal that melts at a very low temperature, releasing the shutter)). It is important that any new openings made in fire break walls are reinstated or protected in some way (e.g. when cables are run through a hole in a wall, the hole might be filled with fire-retardant foam).

### Legal Standards

- ILO C155 – Occupational Safety and Health Convention, 1981 (No. 155).
- ILO R164 – Occupational Safety and Health Recommendation, 1981 (No. 164).

### STUDY QUESTIONS

6. Outline measures to minimise the risk of fire in a woodworking area.
7. Identify the precautions that should be taken when using flammable liquids.
8. Outline the effects of fire on an unprotected steel beam.
9. Outline the typical characteristics of a fire door.

(Suggested Answers are at the end.)

## Fire Alarms and Fire-Fighting

### IN THIS SECTION...

- When a fire starts in a building, there must be an appropriate system to detect the fire early and raise the alarm with building occupants. A range of detection and alarm systems exist, with larger workplaces having fully automatic fire alarm systems relying on automated smoke or heat detectors linked into a central control system, in turn linked to alarm sounders/indicator lights.
- There must also be portable fire extinguishers available so that people can fight the fire if necessary. Fire extinguishers contain different extinguishing media, such as water, carbon dioxide (CO<sub>2</sub>), foam, dry powder and wet chemical. Each type of extinguisher is designed for use on specific classes of fire in different circumstances and each has strengths and limitations.
- All portable fire extinguishers must be inspected and maintained routinely to ensure safe operation. Training should be provided to users so that they can use extinguishers safely and effectively.

### Fire Detection and Alarm Systems

One of the most critical factors in determining whether people live or die in a fire in a workplace is how quickly the fire is detected and how quickly people are alerted. This is also a critical factor in determining how easily the fire will be controlled and extinguished.

Ideally, fires will be detected as soon as they start, and building occupants will be alerted to the presence of the fire immediately, so that an appropriate response can be mounted. This response should usually be a full building evacuation and a call to the local fire service.

It is, therefore, essential that an appropriate fire detection and alarm system is used in a workplace. The exact type of system used will be subject to the fire risk assessment, local building regulations, guidance and standards, but some general principles can be applied:

- **The simplest system** – in a very simple, low fire-risk workplace where all parts of the workplace can be seen by the occupants and there is no great fire risk, then no detection or alarm system may be required. If there is a fire, people will see the fire and shout 'fire'. This may be acceptable as long as the workplace is not so large that some people would not hear that shout.
- **Simple with more noise** – if the workplace is simple and low-risk, but large enough that building occupants might not hear a shouted alarm, then a hand-operated alarm might be used (such as a hand bell, whistle or air horn).
- **Manually operated fire alarm** – the next step up is a fire alarm system that can be manually activated from call points. These call points are usually buttons behind a clear plastic disc that, when hit, break and activate the system. The system will have a central control box and sounders (and/or lights) at positions throughout the workplace that give the alarm.
- **Interlinked smoke alarms** – if there are rooms (such as plant rooms or stores) that are not normally occupied (so a fire might start there and no-one would notice), then a simple automatic detection and alarm system might be fitted, made up of interlinked smoke alarms. This consists of individual ceiling-mounted units that detect smoke from the fire and give the alarm sound. These are linked together so that when one sounder activates, all of the sounders emit the alarm.



Fire alarm

- **Automatic fire detection and alarm** – this system is made up of automatic detectors and manual call points linked into a central control box, linked in turn to sounders (and/or lights). If a person sees the fire, they can activate a manual call point and raise the alarm. If there is no person present, then the automatic detectors will activate the system and raise the alarm. This type of system is commonly used to protect medium- to high-risk workplaces, multi-storey buildings and workplaces where sleeping accommodation is provided (such as care homes).

An automatic fire alarm system can be quite simple or very complicated, depending on the workplace in which it is installed. In some workplaces, the building is subdivided into zones and the fire alarm system can give different warning sounds in different zones, depending on which zone the fire was detected in. In this way, phased (or staged) evacuations (see later) can be achieved.

The type of automatic fire detector that is used with a fire alarm system also varies, depending on the situation:

- **Smoke detectors** are very common, and:
  - Detect small smoke particles, are usually very sensitive and give early warning.
  - Are of two main types: ionising and optical.
  - Can give rise to false alarms if used in a humid, wet, dusty or smoke-filled atmosphere.
- **Heat detectors** are more suitable for certain applications, and:
  - Detect the excess heat generated by a fire, are usually less sensitive and give later warning.
  - Come in two main types: rate of rise and fixed temperature.
  - May not detect smouldering fires that are giving off smoke but not much heat.



Smoke detector

## Portable Fire-Fighting Equipment

If a fire starts in a workplace, it may be possible to extinguish that fire quickly and effectively using a portable fire extinguisher. This might be done with minimal risk to the user, so preventing the fire from escalating, potentially saving lives and property. If there is no portable fire extinguisher present, there will be no choice but to leave the fire to burn out of control.

In addition to the portable extinguishers, other fire-fighting equipment can be found in workplaces, such as:

- **Fire blankets** – used to physically smother small fires. Very useful for cooking areas where fat fires might occur and also for smothering burning clothing.
- **Hose reels** – sited in buildings to allow fire teams to fight fires.
- **Sprinkler systems** – sited in buildings and warehouses to automatically douse a fire.

## Extinguishing Media

Fire extinguishers can contain different extinguishing media depending on the class of fire that they are intended for use on (in the EU regime, Classes A–D and F). The class of fire is indicated on the extinguisher with a symbol and letter. The fire extinguisher may also be labelled with the medium that it contains. Fire extinguishers are usually coloured red.

(In the UK, a colour-coding system was historically used for extinguishers to enable quick recognition of the different types, and this colour coding has been retained to a degree – a small part of the body of the extinguisher, or the label, may be colour-coded.)

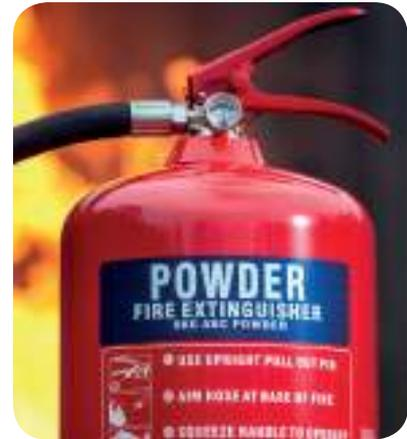

ABC powder fire extinguisher

### TOPIC FOCUS

The following types of portable fire extinguisher are commonly found in workplaces:

- **Water** – suitable for Class A fires. It works by cooling the fire. A standard water extinguisher is not suitable for use on Class B, D or F fires or electrical fires (this might lead to risk of shock). Certain specialised water extinguishers are available for use on Class B and F fires.
- **Carbon dioxide** (CO<sub>2</sub>) – suitable for Class B fires and electrical fires. It works by smothering the fire. It is not suitable for use on Class D or F fires. It must be used with care because the body of the extinguisher gets very cold during use and can cause a freeze-burn injury. CO<sub>2</sub> is an asphyxiant gas and so care must be exercised when using in an enclosed space.
- **Foam** – suitable for Class A and B fires. It works by smothering the fire or by preventing combustible vapours from mixing with air. Some specialist foam can be used on electrical fires but, again, the user must be certain that they are using the right type. As the foam is wet, it is not suitable for Class F hot-fat fires.
- **Dry powder** – suitable for all classes, including electrical fires, with the exception of Class F. It works by smothering the flames and may chemically interfere with the combustion process. It can be very messy and the powder must not be inhaled (so not recommended for use in a confined space).
- **Wet chemical** – specifically designed to deal with high-temperature (>360°C) oil/fat fires (Class F). It reacts with burning oil to form thick suds, cooling and emulsifying the oil, putting out the flames and sealing the surface.

	 WATER	 FOAM	 CARBON DIOXIDE	 POWDER	 WET CHEMICAL
 A					
 B					
 C					
 D					
 F					
					

Classes of fire and extinguishing media

## Siting, Maintenance and Training

Fire extinguishers should be positioned on fire exit routes, near exit doors and close to the specific hazard that they are provided to protect against (e.g. a fire blanket close to a gas hob in a kitchen). Ideally, no-one should have to travel more than 30 metres to reach an extinguisher. Fire extinguishers should be fixed to the wall at a comfortable height (usually 1 metre for larger extinguishers and 1.5 metres for smaller ones) or may be on stands/trolleys. They should be clearly visible and signed.

Fire extinguishers must be **inspected and maintained** routinely to ensure that they are always available in safe working order:

- **Frequent routine inspections** – ensure that extinguishers are present at their designated positions and that they appear to be in good order (with their firing pin still tagged in place). This might be done as part of a routine housekeeping inspection or as a specific fire safety check, perhaps by fire wardens.
- **Planned preventive maintenance** – ensure that they remain in safe working order. This is normally carried out on an annual basis by a certificated engineer and may involve inspection, testing and dismantling (depending on the type of extinguisher).

Records should be kept of visual inspection and maintenance checks carried out.

Workers who might have to use portable fire extinguishers should be trained in safe use. This will be determined by a fire risk assessment. This training should include theoretical training (classroom-based) but should also include some practical training. This will normally involve workers using real fire extinguishers to put out real fires, set up under controlled circumstances either at the workplace or at a training centre. A typical training course would include:

- A general understanding of how extinguishers operate.
- The importance of using the correct extinguisher for different classes of fire.

- Practice in the use of different extinguishers.
- Knowing when to tackle a fire, and when to leave it alone.
- Knowing when to leave a fire that has not been extinguished.

Records should be kept of training provided.

As always, local legislation and code of practice will influence fire extinguisher provision, siting, maintenance and training.

## Access for Fire and Rescue Services

Fire-fighting vehicles need to be able to get close to the perimeter of a building so they can position and deploy high-rise equipment, such as turntable ladders, hydraulic platforms and pump appliances with fire hoses. Fire regulations in some countries may place a duty on occupiers of premises to maintain such access.

The requirements for vehicle access differ depending on the presence of fire mains (a water-supply pipe installed specifically for fire-fighting purposes), the size of the building and the type of fire-fighting vehicle to be used. For example, in the UK, for **small buildings** without a fire main, access for a pump appliance should be provided to 15% of the perimeter or to within 45 metres on every point on the building surrounds; for **large, high-rise buildings**, the entire perimeter will need to be accessible to fire-fighting appliances.

Access for vehicles must be kept clear at all times, and people assembling outside buildings during a fire evacuation must be kept clear of fire-fighting vehicles and fire-fighters so as not to impede their access.

Fire-fighters need to have information about the contents of the building, and about any hazardous materials or processes and facilities that might create a risk to them while they carry out their duties. The emergency plan that the company has in place should include arrangements for nominated and competent persons to liaise with the fire service on their arrival.

It is quite usual for the fire and rescue service to carry out familiarisation visits at industrial premises or premises where there is sleeping accommodation, such as hospitals or care homes.

### STUDY QUESTIONS

10. Identify the limitations of manual alarm systems and how they may be overcome.
11. Identify the two main types of automatic fire detector.
12. Outline the main points to be covered in training in the use of fire extinguishers.
13. Identify the three main ways of extinguishing a fire.
14. Identify the classes of fire for which each of the following extinguishing agents/devices is suitable:
  - (a) Water.
  - (b) Carbon dioxide.
  - (c) Dry powder.
  - (d) Foam.
  - (e) Fire blankets.

(Suggested Answers are at the end.)

# Fire Evacuation

## IN THIS SECTION...

- The means of escape is the route that a person will take from wherever they happen to be in a building to a safe place outdoors.
- There are many factors that influence the means of escape such as: travel distances, number of available escape routes, escape route width, design of any doors in the escape route and provision of suitable assembly points.
- The means of escape must be properly signed and provided with emergency lighting (if necessary).
- Every workplace must have procedures to ensure the safe evacuation of people from buildings in the event of fire.
- These procedures will require nominated staff to carry out certain duties, such as to act as 'fire marshals' (or 'fire wardens'). These nominated staff should be trained in their specific role.
- Information on fire evacuation procedures should be provided to others as appropriate.
- Fire drills allow staff to practise their emergency response and allow management to monitor the effectiveness of emergency arrangements.
- Special procedures may be required to ensure the safe evacuation of the infirm or disabled.
- Means of escape should be shown on the plans of a building.

## Means of Escape

When a fire emergency occurs and people have to evacuate a workplace, there must be one or more escape routes available for them to use. This escape route is the '**means of escape**'. Local regulations, codes of practice and standards vary in determining exactly what might be required in each specific circumstance, but the following general principles can be applied:

- There should be a means of escape available to every person in a workplace, whether they are in an office, workroom, plant room, basement, on the roof or on a scaffold of a construction site.
- The means of escape should allow an able-bodied person to travel the entire route by their own unaided effort. They should not have to use machinery (such as a passenger lift) except in special cases (when the machinery must be rated for escape purposes).
- The means of escape must take a person from wherever they are in the workplace to a place of total safety outside the building where they are able to move away unrestricted.
- Two or more separate escape routes may have to be provided so that if one route is blocked, there is another available. This is common in high-occupancy, multi-storey buildings.
- The travel distance that a person has to cover, from their location in the building to the final exit out of the building, should be as short as possible (and must normally meet maximum distance criteria).
- The width of corridors, passageways and doors should be sufficient to allow the free and fast movement of the numbers of people that might be anticipated (and must normally meet minimum width criteria).
- The escape route should be clearly signed and appropriately lit. Emergency lighting should be provided where necessary (in case the mains power supply fails).
- The route that a person has to take should be unimpeded by obstructions, such as stored material or inappropriate doors.



A fire escape sign and escape light

Many factors affect the exact specification of the means of escape. Two important factors are the **number of people** that will be occupying any given room or area and the general **level of fire risk** of the workplace.

## Travel Distances

One important characteristic of the means of escape is the **travel distance** that a person has to take from wherever they are in a room or area to the nearest available:

- Final exit (this will take them outside the building to a place of total safety).
- Storey exit (this will take them into a protected stairway).
- Separate fire compartment (containing a final exit).

This travel distance has to be assessed during the fire risk assessment when determining the means of escape and is subject to guidance. Generally, the higher the fire risk of the workplace, the shorter the travel distance has to be.

The number of exits is another important characteristic of the means of escape. In some instances, it may be acceptable to provide just one exit route from a room or area. However, if the fire risk is high, the number of occupants is high (>60) or the travel distances are long, then two or more exits must be provided. The underlying principle of having two exits is that a person can turn in two completely different directions and then has two completely separate routes through and out of the building.

## Stairs and Passageways

Stairs and passageways used as escape routes usually have to be protected against fire ingress to a higher degree than other parts of a building. This is to ensure that the stairs and corridors will be free of smoke and flames, so that they can be used as escape routes. So, the walls, floors and ceilings will be fire-resistant and any doors will be fire doors. It is important that these stairs and corridors are kept free from any equipment or materials that might start, or become involved in, a fire.

The width of stairs and corridors should be determined by the number of people who are going to use the route for escape. Higher numbers of people require wider corridors and stairs to move safely and quickly. For example, generally, escape routes should not be less than 750mm wide unless they are to be used by fewer than five people. Escape routes for use by wheelchair users must be wider (minimum 900mm).

## Doors

Doors in the means of escape must be suitable. This means that they:

- Are easily operated by a person in a hurry.
- Are wide enough to allow unimpeded passage.
- Open in the direction of travel (though this is not a strict requirement where occupancy numbers are low).
- Can be opened at all times when they might be needed (not locked with a key or in such a way that a person inside cannot open them).
- May be fitted with a vision panel so that smoke and flames can be seen on the other side of the door before it is opened.



Fire door

## Emergency (Escape) Lighting

Escape routes must be adequately lit. Normal workplace lighting will routinely achieve this, but there should be arrangements to cover non-routine situations, such as power failures. This is especially the case when night-time working is taking place or when the work area is internal to the building or has no external windows (i.e. no natural light).

Emergency escape lighting is necessary where power failure will result in a blackout. In very simple workplaces this may be a rechargeable torch, but in most workplaces emergency lighting units are required.

Emergency escape lighting should:

- Illuminate the escape route.
- Illuminate fire signs and equipment.
- Be maintained in safe working order.
- Be tested routinely.

Routine testing usually takes the form of a monthly function test (to check that the light illuminates) and an annual discharge test. Records of maintenance and tests should be kept.

## Exit and Directional Signs

The escape route should be easy to follow. Signs should be provided so that people can see their available escape routes quickly and easily, leading all the way to the final exit, also signed. These signs should meet the requirements of local legislation. For example, in the UK, the **Health and Safety (Safety Signs and Signals) Regulations 1996** establish the EU standard shape (rectangular), colour (green) and pictogram (which might be an arrow, a running man and a final exit door). They must be carefully selected and fixed so that they are very easy to interpret. Some signs, especially in critical positions, can also incorporate escape lighting, while others may be photoluminescent (they glow in the dark).

## Assembly Points

An assembly point is a place where workers congregate once they have evacuated a building. This allows for a roll call to be taken and identification of any missing persons. Assembly points should be in a place of total safety and:

- A safe distance from the building (it may be on fire).
- At a safe location (not in a high-hazard area).
- At a location where people can move further away if needed.
- Out of the way of fire-fighters.
- Clearly signed.

In some cases, a temporary assembly point or '**refuge**' may be provided inside a building. This might be used as a location where a person with impaired mobility temporarily waits for assistance to evacuate the building.



Assembly point sign

**DEFINITION****REFUGE**

A protected location (normally on, or adjacent to, a main means of escape) where people can wait for a short time.

## Emergency Evacuation Procedures

Every workplace should have arrangements in place to deal with fire emergencies, including:

- evacuation procedures;
- nominating responsible staff to fulfil certain roles;
- training staff and providing information to visitors and members of the public; and
- conducting drills to test procedures.

Emergency procedures must be developed so that staff know what to do in the event of foreseeable fire emergencies. Appropriate procedures should tell people what to do if they discover a fire and what to do if the alarm sounds. These procedures are usually quite simple.

The emphasis in any procedure must be on personal safety and the key message must be to **sound the alarm, get out and stay out!**



Typical fire procedures

More complicated procedures may have to be developed for certain situations. For example, in a hospital, rather than use the basic approach given in the sample procedure, it might be more appropriate to carry out a **phased (staged) evacuation**. Here, only those in the immediate vicinity of the fire are evacuated at first, followed by a gradual evacuation falling back from the seat of the fire. In this way, the large numbers of people and the practical issues associated with moving the infirm might be managed more easily.

## Fire Marshals

Whatever the fire evacuation procedures are, there will always be the need for some members of staff to take on particular roles in the emergency situation, perhaps as nominated **'fire marshals'** (sometimes called 'fire wardens') to take roll calls of workers at assembly points and report back to a responsible manager.

Fire marshals might be required to:

- Check all areas in the building to ensure that everyone knows that an evacuation is in progress and to help where necessary. This is common practice in buildings where members of the public may be present (e.g. shopping centres).
- Give special assistance to the disabled and infirm. This may require the use of special evacuation equipment, such as an 'evac-chair'.
- Investigate the site of the fire (as indicated by the fire alarm system control panel).

Some workplaces operate a **'fire team'** whose role involves investigation of fire alarms and fire-fighting.

High-risk installations may even have their own in-house fire-fighters with all the vehicles, equipment and resources that might be available to the emergency services (e.g. at an airport or chemical plant).

## Roll Call

Once workers and contractors have evacuated a building and collected at their assembly points, it is usual to take a roll call to ensure that all persons are accounted for and no-one is missing. This means that arrangements must be made for taking an effective roll call; accurate lists of names of those on site must be produced and responsible individuals given the task of taking the roll call.

In some cases (e.g. in shopping centres), a roll call will be impractical, in which case an alternative method of ensuring that people have evacuated from the workplace will be required (e.g. building checks by fire marshals).

## Provision for the Infirm and Disabled

Staff with hearing or other disabilities must be accommodated within an evacuation plan. Plans must be in place to assist people with mobility problems or in wheelchairs who cannot use stairs if a lift is inactivated (in many cases, lifts and escalators are not appropriate as escape routes).

Provision must be made for the needs of other groups with limited mobility, such as the elderly or infirm. Temporary illness and infirmity must also be taken into account (e.g. a worker with a broken leg must be accommodated in the evacuation plan).

When these arrangements are put in place, the nature and degree of disability or infirmity must be taken into account, and this is best achieved in consultation with the individual concerned. Various solutions might then be sought.

For example:

- A worker with some hearing impairment might be capable of hearing the audible fire alarm in their work area, so no special arrangements are required.

- A profoundly deaf worker might not be able to hear the audible fire alarm, in which case a visible alarm (flashing light) might be used in conjunction with the audible alarm. Or a buddy system might be adopted where a colleague alerts the worker to the fire alarm. Or a technical solution might be sought involving a vibrating pager.
- A wheelchair user above ground level in a multi-storey building might be provided with a refuge adjacent to the stairwell. They might then be assisted down the stairs by nominated responsible individuals, perhaps with the aid of an 'evac-chair'. It must be noted that they should not be left alone in the refuge and that their safe evacuation is the responsibility of their employer, not the fire and rescue service.

In many instances, the specific arrangements for safe evacuation of a disabled person will require the development of a Personal Emergency Evacuation Plan (PEEP). This should always be done with consideration of the personal dignity of the individual concerned. Note that it is important to take other employment law, such as disability discrimination law, into account. For example, in the UK, the **Equality Act 2010** makes it potentially unlawful to discriminate against someone on the basis of their disability.

## Building Plans and Emergency Escapes

The means of escape should be shown on the building plans. These plans usually constitute one of the records of the fire risk assessment. In some instances, building plans should be posted in the building so that the people inside can clearly see what their escape route should be (e.g. in hotel rooms).

### TOPIC FOCUS

#### Fire Plans

The following factors should be considered when developing a fire plan:

- Details of who is likely to be in the building:
  - Workers.
  - Visitors.
  - Contractors.
  - Vulnerable persons.
- Action to be taken by the person who finds the fire:
  - How will the alarm be raised?
  - How will the emergency services be contacted (will this be an automatic system or will someone be required to phone the fire service)?
- Escape routes:
  - Number and location.
  - Travel distances.
  - Provision of fire exit route signs.
  - Emergency lighting of escape corridors and stairwells.
- Fire-fighting equipment:
  - Provision of portable equipment (types and location).

(Continued)

### TOPIC FOCUS

- Action to be taken after evacuation:
  - Roll call.
  - Fire marshals to check building is evacuated.
- Training in:
  - Use of equipment.
  - Fire drills.
  - Co-operation with other employers on site.

## Training and Information

All workers in a workplace should be provided with basic information about fire safety in general and the fire procedures in particular. This should be given at induction and might be repeated periodically or as the need arises.

Information on fire procedures should also be provided to contractors and visitors, perhaps through induction training programmes, or by providing them with written information.

Informing members of the public about fire procedures can be more of a problem since, in many workplaces, they can walk in off the street and there is no opportunity for providing them with written information (e.g. at a shopping centre).

In these circumstances, a public address system may be the best way of keeping the public informed of an emergency situation and the action that they should take.

Appropriate additional training should be provided to staff who:

- Might have to use portable fire extinguishers or other fire-fighting equipment.
- Have a fire marshalling role.
- Will be assisting infirm or disabled people during an evacuation.
- Are members of the fire team.

Records of all training should be kept. Employers must take into account the health and safety capabilities of workers when entrusting them with fire safety tasks. This will apply at all levels of worker training, including competent persons, fire marshals, etc.

## Fire Drills

Fire evacuation arrangements need to be tested by carrying out fire drills. Generally, fire drills should be conducted annually (the actual frequency should be determined by the fire risk assessment).

Fire drills:

- Allow workers to practise emergency procedures.
- Enable the effectiveness of procedures to be tested to ensure that fast, effective evacuation of the building takes place and that all workers behave in an appropriate manner.

Records of fire drills, learning points and follow-up actions should be kept.

### Legal Standards

- ILO C155 – Occupational Safety and Health Convention, 1981 (No. 155).
- ILO R164 – Occupational Safety and Health Recommendation, 1981 (No. 164).
- ISO 7010: International standard for safety signs.

### STUDY QUESTIONS

15. Identify the purpose of signs used on escape routes.
16. Outline the main requirements for an escape route.
17. What is an assembly point and how might it differ from a refuge?
18. Outline the possible responsibilities of fire marshals during a fire evacuation.
19. What might take place at an assembly point following an evacuation?

(Suggested Answers are at the end.)



## Summary

---

This element has dealt with some of the hazards and controls relevant to fire in the workplace.

In particular, this element has:

- Outlined some of the basic principles of fire safety such as: the fire triangle, the five classes of fire, the methods by which fire can spread and some of the common causes of workplace fires.
- Explained how fire and the spread of fire can be prevented by controlling potential fuel sources (e.g. safe use and storage of flammable liquids) and potential ignition sources (e.g. hot works).
- Outlined the structural measures that exist to contain fire and smoke in the event of a fire starting, and the use of self-closing fire doors to protect door openings.
- Described the general principles of fire detection and alarm systems.
- Discussed the main types of fire extinguisher commonly used such as water, CO<sub>2</sub>, foam, dry powder and wet chemical, and the strengths and limitations of each type.
- Outlined the principal characteristics of a means of escape such as: travel distances, number of available escape routes, escape route width, design of any doors in the escape route, assembly points, signage and emergency lighting.
- Described basic requirements for evacuation procedures, fire marshals, training and information, the capabilities of workers, fire drills and special procedures for the infirm or disabled, and the inclusion of escape routes in building plans.

# Practical Assessment Guidance

## Part 4 – Review, Communicate and Check



In the final part of the Practical Assessment Guidance, we will look at Part 4 of the assessment which requires you to indicate when you intend to review your risk assessment, and how you intend to communicate the findings and follow up the assessment to check that actions have been carried out.



### Part 4: Review, communicate and check

You must now give a review date for your risk assessment and say why you have chosen this date (10 to 50 words)

You must now describe how the risk assessment findings will be communicated (including who needs to know the information) (100 to 250 words)

You must now describe how you will follow-up on the risk assessment to check that the actions have been carried out (100 to 150 words)

**Note:** These forms are for reference purposes only. Please visit the NEBOSH website to obtain the official forms to submit your assessment.

The last step in completing the practical assessment is to complete Part 4 of the assessment form.

This is split up into three boxes:

- In the first box, you must give a risk assessment review date and explain why you have chosen that date. It is probably sensible to state a timescale for the risk assessment review (e.g. 1 year) and state the date that this would be on relative to the date that you put at the top of the risk assessment form (e.g. 31 August 2020). You must justify your choice of review date so that the examiner can understand why you picked that date.  
NEBOSH indicates 10–50 words for this information.
- In the second box, you must explain who you will communicate the findings of the risk assessment to and how. A range of people may need to know the result of the assessment (for example, the workers directly involved, responsible managers, directors and those with specific actions allocated to them) and the results might be communicated in various ways (by issuing hard copies of the assessment, through toolbox talks or safety briefings, in training sessions, via one-to-one meetings, via the organisation's intranet system, etc.).  
NEBOSH indicates 100–150 words for this section.
- In the third and last box, you must explain how you intend to follow up your risk assessment to check that all of the identified actions have been carried out. You should think about how you will track each action forward, how you will set reminders before each action becomes due, how you will liaise with each responsible person to keep track of overdue actions and how you will escalate long overdue actions that do not appear to have been adequately addressed.  
NEBOSH indicates 100–150 words for this section.

The key issue is that the examiner must see that, having completed a risk assessment, you are able to propose sensible and realistic follow up action that will yield practical results.

Before you finish with Part 4 and move on to the final submission of your practical assessment, just check to ensure that you have addressed all of the information requested in italics at the top of each box on the Part 4 form.

## Final Submission

Don't forget to check that your name and learner number are written on all parts of the form that you submit.

Once you have filled in all parts of the form, you have completed the practical assessment, and can then submit it for marking. Practical assessments are submitted directly to NEBOSH by following their submission process (see the NEBOSH website for further details or talk to your course provider). NEBOSH will mark the assessment and send your results directly to you.

You can handwrite your assessments or complete them electronically. We recommend electronic completion as this gives a more professional appearance.

Please note that NEBOSH reserves the right to submit your assessments to a plagiarism detection software package. Cases of suspected plagiarism will be investigated by NEBOSH and proven cases will be dealt with in line with their malpractice policies.

A worked example of a completed practical assessment is presented at the end of Element 11. Additional useful information and some summary tips are included in the Final Reminders chapter at the end of Unit IG2.



# Electricity



## Learning Objectives

Once you've studied this element, you should be able to:

- 1 Describe the hazards and risks associated with the use of electricity in the workplace.
- 2 Describe the control measures that should be taken when working with electrical systems or using electrical equipment in all workplace conditions.

<b>The Hazards and Risks of Electricity</b>	<b>11-3</b>
Introduction to Electricity	11-3
The Hazards and Risks of Electricity	11-4
Dangerous Activities	11-7
<b>Control Measures</b>	<b>11-10</b>
Introduction to Control Measures	11-10
Protective Systems and Devices	11-11
Competent Persons	11-14
Use of Safe Systems of Work	11-15
Emergency Procedures Following an Electrical Incident	11-16
Inspection and Maintenance Strategies	11-17
<b>Summary</b>	<b>11-22</b>
<b>Practical Assessment Guidance</b>	<b>11-23</b>

## The Hazards and Risks of Electricity

### IN THIS SECTION...

- The risks of electricity are electric shock, burns (both direct and indirect), fire and explosion, arcing, and secondary effects.
- When a person receives an electric shock they can suffer a range of effects from mild discomfort and muscle tremor, uncontrollable muscle contractions and respiratory failure, to Ventricular Fibrillation (VF), cardiac arrest and severe burns.
- The severity of injury is influenced by several factors, such as system voltage, duration of contact, pathway through the body, body resistance, contact surface area, environmental factors and frequency.
- Care must be taken when treating an electric shock victim to minimise risk to the first aider.
- Portable electrical equipment is often involved in electrical accidents because it is frequently unsuitable for the job being done, misused, and not inspected or maintained.
- High-risk work activities include the use of poorly maintained electrical equipment, work near overhead power lines, contact with underground power cables, work on live supplies and the use of electrical equipment in wet environments.

### Introduction to Electricity

Electricity is the flow of electrons through a conductor. A commonly used conductor is copper wire. For electricity to flow, the conductor must be arranged with a power source to make a **circuit**. A very simple circuit – as shown in the figure – is where a battery and a light bulb have been connected together using copper wire to form a loop. Electricity flows in one direction around the circuit, from one terminal of the battery to the other. As it passes through the bulb, the filament in the bulb resists the flow of electricity, heats up and emits light. If the wire is disconnected from the battery or bulb, the circuit is broken, the flow stops and the bulb goes out.

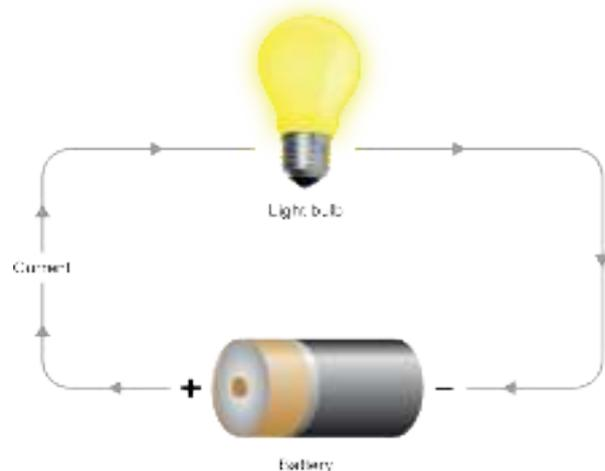

A simple electrical circuit

The basic parameters of an electrical system, such as the circuit shown, are:

- **Voltage (V)** – a measure of the potential difference or electrical driving force/pressure that is forcing electricity through the conductor (unit: volt; symbol: V).
- **Current (I)** – a measure of the rate of flow of electricity through a conductor (unit: amp; symbol: A).
- **Resistance (R)** – a measure of how much a component in the circuit resists the passage of electricity (unit: ohm; symbol:  $\Omega$ ).

These three parameters are linked by a simple relationship called **Ohm's law**:

Voltage = Current  $\times$  Resistance

Volts = Amps  $\times$  Ohms

$V = I \times R$

One other characteristic of electrical systems is the nature of the current flow. In our basic circuit, the current flows in one direction only – from one terminal of the battery to the other. This is referred to as **Direct Current (DC)** and is usual for battery-supplied electrical systems. The mains supply, however, in domestic houses and workplaces, flows forwards and backwards through the circuit and is known as **Alternating Current (AC)**. The rate at which AC current switches backwards and forwards is called the frequency – the number of cycles per second (unit: hertz; symbol Hz).

For example, in the UK, the mains electricity supply is 230 V, 50 Hz. In the US, it is 120 V, 60 Hz.

## The Hazards and Risks of Electricity

The hazards and risks of electricity are:

- Electric shock.
- Burns.
- Fires and explosions.
- Arcing.
- Secondary effects.

Accidents involving electricity frequently include two or more of these hazards and risks at the same time. Each will be looked at in turn.

### Electric Shock

#### DEFINITION

##### LIVE AND DEAD

When a system is connected to an electrical power source, it is described as 'live' (in some countries, the expression 'hot' is used instead). Once it has been disconnected from its power source and all stored power has been released, it can be described as 'dead'.

Electric shock occurs when a person touches a live surface (a conductor at a different potential difference to neutral/earth) and an electrical current passes through their body. The electrical current uses the body as a conductor. The current will, therefore, have a pathway through the body, from the point of contact with the live surface (where the current enters the body) to another point of contact with the ground or earthed surfaces (where the electrical current leaves the body). Put simply, the human body can be thought of as replacing the light bulb component in our simple circuit.

When a person receives an electric shock, it can have a range of effects. The most important factor that determines what the effects will be is the amount of current (amps) that flows through the body. The following table indicates the range of effects that might be experienced at different current flows.

## The effects of current flow on the body during an electric shock

Current (mA) Flowing Through the Body	Effect
0.5–2	Threshold of sensation.
2–10	Tingling sensations, muscle tremor, painful sensations.
10–60	Muscle contractions, inability to let go, inability to breathe.
60 and above	Ventricular fibrillation, cardiac arrest, extreme muscle contractions, burns at contact points and deep tissues.

(Note: the current is measured in milliamps (mA). One milliamp is one thousandth of an amp ( $1 \text{ mA} = 0.001 \text{ A}$ ). The current is AC.)

The table illustrates that:

- At very low current flow (less than 0.5–2 mA), **no sensation** is felt by the person receiving the shock.
- Between 2 and 10 mA, the current starts to flow through the body and stimulates muscles to contract. This can be felt, it causes muscles to **tremble** and it may **hurt**. But the person receiving the shock is able to control their muscles and can let go of the live object.
- Between 10 and 60 mA, the current starts to cause more **severe muscle contractions** and these may become so strong that the person cannot control their muscles and they grip onto the live object. When this occurs, the muscles of the rib cage and abdomen may contract so that the person **cannot breathe** (which means that they cannot call for help) and they may asphyxiate. Alternatively, the shock may cause a **massive contraction** of big muscle groups so that the person is thrown violently off their feet (hopefully away from the live object).
- At current flows above 60 mA, there is the possibility of **Ventricular Fibrillation (VF)**, where the heart is no longer beating in a synchronised, rhythmic manner, but spasmodically (writhing like a can of worms). This usually leads to **cardiac arrest**. As the current increases above 80 mA, the possibility of VF becomes greater. Muscle contractions can become so extreme that bones are broken, **burns** will occur at the entry and exit points, and in the tissues that the current has passed through. **Death** becomes more likely as the current increases.

### TOPIC FOCUS

Several factors influence the severity of injury associated with receiving an electric shock:

- **Voltage** – as Ohm’s law shows, there is a simple relationship between voltage and current: the higher the voltage, the greater the shock current through the body.
- **Duration** – the length of time that a person is exposed to the flow of electricity is critical. For example, a current flow of 60 mA for 30 milliseconds (30 thousandths of a second) is unlikely to cause a severe injury, whereas the same current flow over a period of two seconds can induce VF and prove fatal.
- **Current path** – the route that the electricity takes as it flows through the body is also critical. If it runs through the chest, it is likely to affect the heart.

(Continued)

### TOPIC FOCUS

- **Resistance** – as Ohm’s law shows, there is a simple inverse relationship between current and resistance – the higher the resistance, the lower the current. Most of the body’s resistance to the passage of electricity is because of the skin. A person with dry skin has a high resistance, but if their skin is wet or damaged, this reduces dramatically. The resistance of the person will be influenced by various factors, such as:
  - **Contact surface area** – the more skin that is in contact with the live surface, the lower the resistance, the greater the current flow and the more severe the injury.
  - **Environment** – any environmental factors that reduce resistance will cause an increase in current flow and therefore increase the severity of the shock (e.g. wet surfaces, humid air, metal surfaces).
  - **Clothing and footwear** – worn by the person, will similarly affect resistance and hence block or reduce current flow.
- **AC or DC** – AC is capable of causing more severe effects at lower shock current than the equivalent DC shock.

## Electrical Burns

People receive burns in two different ways during electrical accidents:

- **Direct electrical burns** – occur when the current causes overheating as it passes through the skin and the internal tissues of the body. There may be entry and exit skin burns and these will be full skin thickness (third-degree burns). The internal tissue burns can be very severe and may prove fatal.
- **Indirect electrical burns** – do not occur as a result of the current passing through the body but when an electrical accident causes something to overheat and explode. For example, dropping a spanner onto a high-voltage cable can cause a short circuit which results in a flash of radiant heat and an explosion of molten metal.

## Electrical Fires and Explosions

Electricity can cause fires and explosions in several different ways:

- Electrical equipment may be faulty and overheat as a result, leading to a fire.
- The system may be overloaded; as too much current passes through, it overheats, causing fire or explosion.
- Overheating during charging. Many portable or mobile devices can become hot during the charging process. This is particularly the case if the equipment is faulty or of poor quality (e.g. counterfeit mobile phone batteries and chargers).
- Equipment may be misused (e.g. it may be connected into the mains supply by pushing bare wires into the socket rather than using the proper plug).
- A flammable atmosphere may be present which electricity ignites. This can happen in two different sets of circumstances:
  - The wrong type of electrical equipment is brought into an already known existing flammable atmosphere.
  - A flammable atmosphere is accidentally created in an area where it would not be expected (e.g. due to spillage). (This is covered in more detail in Element 10.)
- Electrical equipment may produce heat or sparks as part of its normal operation (e.g. a fan heater gets hot during use). If it is poorly positioned next to a full waste paper bin, it may start a fire.

One common cause of overheating electrical equipment is poor internal connections. When two electrical components are joined together, the connection between them must be well made and secure. A poor connection causes an increased resistance which, in turn, leads to overheating at the connection point. Poor connections can occur because the connection was not properly made when the equipment was being manufactured or installed, but they can also occur as a result of loosening of parts over time. Fixed installation, such as distribution boards, can suffer this type of failure.

## Arcing

Arcing is where electricity jumps across an air gap. It occurs in a limited way inside some low-voltage electrical equipment (e.g. a portable electric drill). The dangers associated with arcing increase at higher voltages because the distance that electricity can arc through air is determined primarily by voltage: the higher the voltage, the greater the distance. High-voltage power lines can arc across distances of over 10 metres through the air.

The main risks associated with arcing are:

- Electric shock as a result of being struck by the arc.
- Direct burns as a result of being struck by the arc.
- Indirect burns from the radiant heat given off by the arc and from the melting of any equipment struck.
- Damage to the eye as a result of the ultraviolet (UV) light that is emitted by the arc.

## Secondary Effects

Put simply, the secondary effects are any sort of injury that results indirectly from receiving an electric shock. Common secondary effect injuries occur when people undergo violent muscle contractions during an electric shock accident. They may be thrown across a room and receive cuts, bruises and broken bones as a result. If they happen to be working at height off a ladder, then even a relatively minor shock can induce enough of a reaction to cause a fall.

## Dangerous Activities

### Fixed and Portable Electrical Equipment

A wide variety of workplace equipment is operated by electricity, some being **fixed systems** 'hard-wired' directly into the distribution system (such as wall sockets and ceiling lights), others being portable appliances. The same hazards apply to all of these, but the risks can be different, especially with portable appliances.

Hard-wired equipment needs to be inspected and tested (see later) to ensure connections and system components remain secure and operational, particularly cables that may be exposed to pedestrian and vehicle traffic. However, it is less likely to undergo the rigours of being unplugged and moved around the workplace.

**Portable electrical equipment** can be defined as equipment, with a flex and plug, that can be moved from one location to another for use. (Whether it is actually moved is irrelevant; a photocopier may never be moved but it has a flex and plug and is, therefore, portable.)

A high proportion of electric shock accidents involve portable electrical equipment.

As an example of vulnerable portable electrical equipment, consider a small concrete breaker on a construction site. It is:

- Subject to frequent heavy use in an outdoor environment.
- Often handled and transported.
- Used by a variety of workers who may not own the item and therefore have little interest in taking care of it.

### TOPIC FOCUS

Conditions and practices likely to lead to accidents:

- Use of unsuitable equipment (e.g. the use of non-intrinsically safe equipment in a flammable atmosphere).
- Use of equipment in wet, damp or humid conditions.
- Misuse (e.g. sticking wires directly into a socket rather than using a plug).
- Physical abuse (e.g. pulling the plug out by tugging at the flex; carrying the tool by the flex; allowing the flex to be pinched, trapped or crushed).
- Repairs carried out by unauthorised personnel or carried out badly (e.g. split flex taped up with insulating tape).
- Continued use of faulty, defective equipment.
- Chemical damage to the flex (e.g. by corrosive wet cement).
- Lack of routine inspection, testing or maintenance.

### Use of Electrical Equipment in Wet Environments

Because water decreases the resistance of objects and environments to the passage of electricity, any work using electrical equipment in wet environments increases risk. Not only are electric-shock accidents more likely to happen in wet environments (because normally insulating materials will start to conduct), but the severity of injury received can be greater (because lower resistance means higher current flow).

### Work Near Overhead Power Lines

Most overhead power lines are uninsulated (bare conductors). As a consequence, any work conducted near these power lines has a risk of electrical arcing. The distance that the arc can jump will depend on the voltage of the electrical system and environmental factors (such as air humidity). A typical high-voltage overhead power line in the UK will be at 11000 V (11 kilovolts (kV)).

### Contact with Underground Power Cables

Both low-voltage (<1000 V) and high-voltage (>1000 V) power cables are routinely buried in the ground. When electrical cables are struck during excavation work, this can lead to electric arcing, shock, burns and fire, not to mention major business disruption to service users. Cables can be struck using hand tools such as spades and pneumatic drills, and by mechanical excavators. Note that it is not necessary to sever a cable or cut completely through the insulation to the cores inside to cause damage. Crushing the cores of an armoured cable can be enough to cause catastrophic arcing and explosion.

### Work on Mains Electricity Supplies

Work on or near any exposed **live** mains supply conductors (e.g. the 230 V AC fixed installation in a building) is inherently high risk because of the severity of injury in the event of an accident. Work on any part of the mains supply distribution network is doubly dangerous because of the high voltages of the distribution network (e.g. 400,000 V) and the fact that most overhead cables are uninsulated bare conductors.

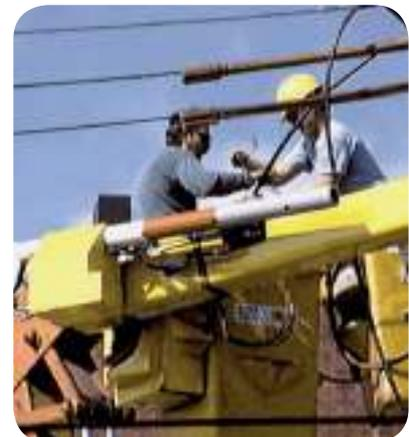

Working near overhead power lines

**MORE...**

The HSE website contains more information on the hazards and risk of electricity at:

[www.hse.gov.uk/electricity](http://www.hse.gov.uk/electricity)

**STUDY QUESTIONS**

1. Outline the main effects of electric shock on the body.
2. Explain what arcing is and what risks it poses.

(Suggested Answers are at the end.)

## Control Measures

### IN THIS SECTION...

- Electrical equipment must be carefully selected to ensure that it is suitable for the electrical system, purpose and environment of use.
- Various protective systems can be used for electrical equipment, such as:
  - Fuses – a weak link in the circuit.
  - Earthing – a low-resistance path to earth for fault current.
  - Isolation – cutting the power.
  - Double insulation – separating people from the conductors using two layers of insulation.
  - Residual Current Devices (RCDs) – sensitive and fast-acting trips.
  - Reduced and low voltage – so that less current flows during an electric shock accident.
- Each of these protective systems has advantages and limitations.
- Work on electrical systems should be restricted to competent people only.
- Safe Systems of Work (SSWs) should be used when risk is created by work on, or near, electrical systems.
- All electrical installations, equipment and appliances should be subject to user checks, formal visual inspections, and combined inspection and testing to ensure electrical safety.

## Introduction to Control Measures

Electricity is subject to a range of regional and local legislation, codes of practice, guidance and standards. For the purposes of this course, the following control measures are based on UK legislation and standards. In the UK, the principal piece of legislation is the **Electricity at Work Regulations 1989**, supported by the **IET Wiring Regulations** and guidance such as HSR25 *Electricity at Work Regulations 1989 – Guidance on regulations* and HSG85 *Electricity at work – Safe working practices*.

## Protection of Conductors

Electrical conductors should be protected so that people are not exposed to live conductors. This is normally done by covering conductors in insulating material (such as the two layers of plastic insulation around an electrical flex) or placing them inside enclosures (such as the enclosure around a desktop computer or the casing on a mains-powered portable drill). In some cases, conductors are not directly insulated or enclosed; instead they are put in a safe place where it is very difficult for people to come near them (such as high-voltage overhead power lines).

It is essential that equipment is inspected and maintained to ensure that the insulation and protective layers are not damaged, and that where access may be possible (e.g. via an electrical panel or switchgear), the access doors are locked and controlled.

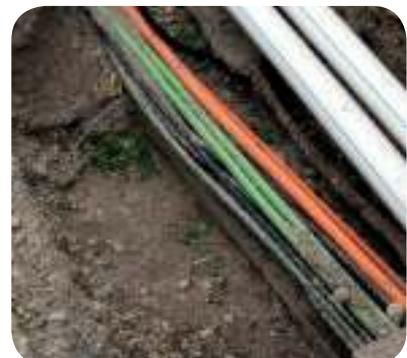

Cables should be insulated by an unbroken, undamaged sheath

## Strength and Capability of Equipment

Electrical equipment must be carefully selected to ensure that it is suitable for the:

- electrical system that it will become a part of;
- task that it will perform; and
- environment in which it will be used.

No electrical equipment should be put into use where its electrical **strength and capability** may be exceeded and give rise to danger. It should be able to withstand normal, overload and fault currents. It should be used within the manufacturer's rating and in accordance with any instructions supplied. This may require reference to electrical specifications and tests undertaken by the manufacturer and accredited testing organisations, based on international and national standards.

If the equipment might be exposed to hazardous environments, then it should be constructed and protected to prevent danger. The following hazardous environments should be taken into account:

- **Weather** – equipment and cables may need to withstand exposure to rain, snow, ice, wind, dust and lightning.
- **Natural hazards**, such as solar radiation, plants and animals (e.g. gnawing of cables by rats).
- **Extremes of temperature and pressure**, such as heat from motors.
- **Dirty conditions** – contamination by liquids or solids.
- **Corrosive conditions** – caused by chemicals.
- **Liquids and vapours** – immersion, splashing or spraying with water and solvent vapours, etc.
- **Flammable substances**, such as flammable gases, dusts and vapours.

Foreseeable mechanical damage must also be considered, both in terms of the environment in which the equipment is to be used, and the natural operation of the equipment itself. For example, abrasion may be caused by mechanical movement leading to damage of the flex; this might be prevented by using an armoured flex.

## Protective Systems and Devices

A range of protective systems and devices are used to control the risks associated with electricity. Most of these can be found in the domestic home as well as at work. The next section gives an overview of the range of control measures and looks at the advantages and limitations of each.

### Fuses and Miniature Circuit Breakers

A **fuse** is a device used to prevent **current overload** (sometimes called **overcurrent** protection). A simple fuse is made up of two metal caps joined by a thin piece of fuse wire. When this fuse is incorporated into an electrical circuit, current flows through the wire. If the current is too great for the fuse wire rating, the wire becomes hot and melts. This breaks the circuit. In effect, the fuse is the weak link in the circuit.

**Advantages** of fuses are that they:

- Are very cheap and reliable.
- Offer a good level of protection for the electrical equipment against current overload that might damage the equipment or cause overheating, fire or explosion.

**Limitations** of fuses are that they:

- Primarily protect equipment and not people. It is possible to receive a severe, even fatal, electrical shock from equipment that is protected by a fuse for two reasons:
  - A fuse does not stop current flow quickly enough to prevent VF.
  - The current flow must be above the fuse rating for the fuse to operate and this may be above the 60 mA capable of causing fatal injury.
- Are very easy to bypass (e.g. by wrapping the fuse in tin foil).

**Miniature Circuit Breakers (MCBs)** are electromechanical devices that work in a similar way to fuses to protect equipment from current overload (i.e. they provide **overcurrent** protection). One significant difference is that a MCB does not melt in response to current overload; it simply trips out and can be reset by pressing a button. This gives one of the main advantages of MCBs – they do not have to be removed in order to be reset and so they are more tamper-proof than fuses. The limitations of MCBs are similar to those for fuses.

## Earthing

**Earthing** is a way of protecting equipment so that, in the event of an electrical fault, current flows safely to earth rather than flowing through a person who might be touching the equipment.

The earth wire of an item of electrical equipment is usually connected to the outer metal casing or chassis of the equipment. If a fault develops and the casing or chassis becomes live, then a fault current will flow down this earth wire. Electricity always takes the **path of least resistance**, and since the earth wire will have very low resistance, the majority of fault current will flow safely to earth through the wire. Any person touching the casing will receive a minor shock.

**Advantages** of earthing are that it:

- Protects the person from fatal electric shock.
- Often provides secondary protection to the equipment because a large fault current flowing to earth will over-rate and trip the fuse or MCB.

**Limitations** of earthing are that:

- A poor or broken earth connection will prevent the earth from working properly; since the earth wire does not take part in the normal functioning of the equipment, this fault can go completely undetected.
- It is easy to disconnect and disable.

## Isolation of Supply

**Isolation** is the removal of electrical power from a circuit or system. This might be achieved using a switch (isolator) or by pulling the plug out. This makes the system or circuit dead and safe to work on (unless electrical energy is stored in the system).

To ensure safety, isolation should always be physically **secured** before people work on the dead system. This is often achieved by padlocking isolators in the 'off' position (the lock-out/tag-out system). As an additional precaution, the system should then be tested to prove that it is dead (and the test meter used should itself be tested both before and after this proof has been carried out).



The lock-out/tag-out system

The **advantage** of isolation as a form of protection is that it is a very effective method of ensuring that people cannot be injured by electrical energy when working on an electrical system.

The **limitation** of isolation is that, by definition, the electrical system is dead. Certain types of testing, fault-finding and electrical installation and repair work have to be carried out with the electrical system on and live. In these circumstances, isolation cannot be used.

## Double Insulation

The principle behind **double insulation (or Class II equipment)** is that there are two layers of insulation between any potentially live conducting surface that the user might touch (such as the metal casing of the equipment) and any live conductors, or the equipment has a non-conducting plastic casing. This eliminates the need to provide earth protection, so double-insulated equipment will have a two-core flex: live and neutral only.



This symbol is displayed on double-insulated equipment

Double insulation is commonly used as a means of protection for hand-held portable electrical equipment, such as hedge trimmers.

The **advantage** of double insulation is that it relies on insulation rather than the electrical system itself for safety.

The **limitation** of double insulation is that the insulation must be routinely visually inspected because there is no earth protection.

## Residual Current Devices

A **Residual Current Device (RCD)** is specifically designed to protect human life in the event of electric shock. It does so on the basis that it is very sensitive to small current imbalance (30 mA) in a circuit and is able to break the circuit very quickly (40 milliseconds).

The principle of a RCD is that it constantly compares the amount of current flowing down the live and neutral lines and, if an imbalance is detected, it trips the circuit. RCDs (and earth leakage circuit breakers which work on a similar basis) can be:

- Incorporated into electrical equipment (as part of the plug).
- Used as standalone devices placed between a portable appliance plug and the power socket.
- Hard-wired into distribution systems, such as the 'consumer unit' of a domestic house (which, in many countries, has become standard practice for new or rewired houses).

The **advantage** of RCDs is that they provide excellent protection for people in the event of electric shock.

The **limitations** of RCDs are that they:

- Do not provide overcurrent protection (they are not a fuse and work on a completely different principle).
- Have to be tested periodically, to ensure that they are still working effectively, and this is often not done.
- Can cause repeated circuit tripping if there is a fault and this can encourage people to not use them or to disable them.

## Reduced and Low-Voltage Systems

In the UK (where mains supply is 230 V), it is possible to use a transformer to step the voltage down to 110 V for portable power tools. Where environmental conditions are harsh, such as on construction sites or in areas which are wet, and there is a high risk of electric shock, the use of reduced or low voltages is advisable to reduce the effect of any shock.

For hand-held portable tools and the smaller transportable units, a 110 V centre-tap earth system is recommended, using a transformer to reduce the voltage from the public supply. The system relies on the mid-point of the transformer to be earthed (centre-tapped). The maximum shock voltage to earth is then half the supply voltage, i.e. 55 V in the event of direct contact. As most shocks occur between a live part and earth, this is a major step in the reduction of the shock effect. The full 110 V supply is available to power the equipment.

Lower-voltage systems (which are called 'safety extra low voltage') are created by using a safety isolating transformer. This transformer ensures that the voltage between conductors in a circuit (which are isolated from the supply mains and from earth) does not exceed 50 V AC. These systems represent even less of a hazard and should be used in other environments, such as vehicle washing areas and in the vicinity of swimming pools. They are also recommended for hand lamps, soldering irons and other small hand tools where the risk of shock is high.

### TOPIC FOCUS

Control measures to be considered when selecting portable electrical equipment for use on **construction sites** are to:

- Consider the use of battery-powered equipment.
- Consider the use of reduced- and low-voltage (110 V) equipment centre-tapped to earth.
- Provide increased protection through the use of an RCD.
- Locate cables carefully, away from hazards (e.g. vehicles which may drive over them).
- Consider the use of double-insulated equipment.
- Carry out pre-use checks of the equipment for signs of damage.
- Train operators in safe use of the equipment.
- Avoid using in wet conditions (unless the equipment and supply cables are suitable for this).
- Implement a programme of routine visual inspection and thorough testing of electrical equipment and cables.

## Competent Persons

Where work on electrical systems creates danger or risk of personal injury, then the employer must restrict that work to those people who have the necessary technical knowledge or experience to be able to carry out that work safely. In this context, a competent person has:

- Knowledge of electricity.
- Experience of electrical work.
- An understanding of the system to be worked on.
- An understanding of the hazards and the precautions needed.
- The ability to recognise whether it is safe for work to continue.

The extent of personal knowledge and experience needed will have to be decided by the employer. It may be that these requirements can be relaxed, provided an adequate level of supervision is being applied (for example, an apprentice electrician can gain experience provided they are appropriately supervised).

## Use of Safe Systems of Work

Safe Systems of Work (SSWs) must be developed when working on, or near, electrical systems creates risk. Several different types of work activity have to be considered. These are presented next.

### Working on or Near Live Electrical Systems

Work must not be carried out on, or near, live electrical systems except in very particular circumstances (Regulation 14 of the **Electricity at Work Regulations 1989**). Live work should be prohibited in most instances. Where live work is justified (because there is no alternative) then there must be a SSW in place to ensure that the live work can be carried out safely. This SSW is likely to make use of the following controls:

- Permit-to-work system.
- Competent persons.
- Insulating PPE (such as gauntlets and boots).
- Insulated tools and equipment (such as screwdrivers).
- Designated work areas (such as 'earth-free zones').

### Isolation

Most work on electrical systems should be carried out with the system dead. This requires that the system is isolated from its source of electrical power. As previously stated, this isolation usually requires:

- The breaking of the circuit.
- Physical securing of the break in the circuit.
- Some form of label (or tag).

So, for example, the isolator switch for an item of equipment might be switched to the 'off' position, a padlock introduced to secure the isolation, and a tag added to identify the worker and nature of work activity.

### Preventing Buried Cable Strikes

Prevention of striking buried services can be achieved by the use of SSWs, in combination with detection equipment:

1. Plans of the area of the excavation should be obtained. Plans do not necessarily show the exact position of buried services, but can give an indication of the existence of services and an approximate position.
2. The buried services should be located using surface clues and detection equipment. A commonly used device for detecting the location of buried cables is the Cable Avoidance Tool ('CAT scanner').
3. The buried services should be uncovered by careful digging by hand.
4. The exposed services should be identified to ensure that they are those that were expected and be clearly labelled so that their position is easily seen. It may be necessary to support cables where the ground underneath is being removed.

Digging with mechanical equipment can commence once the above points have been addressed.

## Work Near Overhead Power Lines

Since most overhead power lines are uninsulated, danger is created if the power line is touched, or if any conducting material is positioned close enough for electricity to arc across. This might be the case during routine work in any workplace, but is a particular issue associated with construction work. Prevention of accidents associated with proximity to live overhead power cables can be achieved by:

- **Isolating** the power supply when working in the vicinity of power lines. If power cannot be isolated, it may be possible to **sleeve** low-voltage power lines.
- Using **SSWs and permit systems** to control access into danger areas.
- Using **barriers, signage and goal posts** to keep plant and vehicles a safe distance from power lines.
- Using **banksmen** when a plant is manoeuvring near power lines.
- Using **non-conducting equipment**, such as fibreglass ladders.

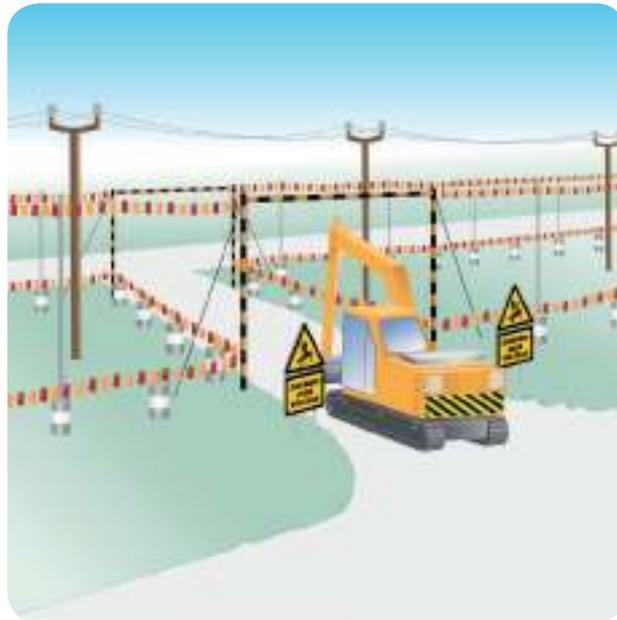

Barriers, bunting and goal posts used to control proximity of plant to overhead power lines

Based on original source: HSG144 *The safe use of vehicles on construction sites* (2nd ed.), HSE, 2009

([www.hse.gov.uk/pubns/priced/hsg144.pdf](http://www.hse.gov.uk/pubns/priced/hsg144.pdf))

## Emergency Procedures Following an Electrical Incident

If, in spite of all the precautions, an electrical incident occurs in the workplace, all workers should be aware of the following method for dealing with an electric shock casualty.

A careful assessment of the situation is needed when approaching the casualty. This is important for two reasons:

- The casualty may still be receiving an electric shock, in which case touching them will involve their potential helper in the shock as well.
- High-voltage conductors can arc electric current through the air over large distances (metres) (as discussed earlier).

In order to provide appropriate casualty care:

- Do not touch the casualty.
- Call for help and an ambulance.
- Turn off the power supply.
- If the power supply cannot be switched off, then carefully push or pull the casualty away from the live part using non-conducting material, such as timber or dry clothing.
- Check breathing:
  - If the casualty is breathing, place them in the recovery position.
  - If they are not breathing, apply cardiopulmonary resuscitation.
- Treat any obvious burns.
- Treat for physiological shock.
- Make sure they get professional medical treatment (heart problems and internal burns may not be apparent to the casualty or first aider).

## Inspection and Maintenance Strategies

**Electrical installations and equipment** should be routinely inspected to ensure electrical safety. This includes:

- The electrical equipment installed in the buildings, such as power distribution circuits and lighting.
- Large items of electrical equipment that are not moved.
- Smaller, portable appliances.

There are standards governing the inspection of fixed electrical installations, or requirements imposed by insurance companies. In many cases, tests should also be carried out to verify the safety of the systems, equipment or appliances in use.

There are several types of inspections and tests that might be appropriate for **portable electrical appliances**. The HSE guidance note HSG107 *Maintaining portable electrical equipment* has information on this topic area.

### User Checks

Some items of electrical equipment should be visually inspected by the user routinely before use. This is particularly important for portable electrical equipment that is used in environments where damage can easily occur (such as a power tool used on a construction site).

This user check does not involve any form of dismantling but just careful visual inspection of the equipment. If visual inspection or tests show that the equipment is unsafe, then it must be taken out of service and repaired or discarded.

Initially, the equipment should be checked for suitability to ensure that it is appropriate for the task in hand, and that the equipment conforms to CE marking and EU conformity requirements.

### TOPIC FOCUS

Things to check during routine visual inspection of a portable appliance include ensuring that:

- The body of the plug is intact and secure.
- The outer sheath of flex covers inner cores into the body of the plug.
- The plug cable clamp appears to be tight.
- The flex appears fully insulated, with no splits or severe kinks/pinches.
- The body of the appliance is intact.
- The outer sheath of flex covers the inner cores into the body of the appliance.
- The appliance cable clamp appears to be tight.
- There are no obvious scorch marks to the plug or appliance body.
- The plug and appliance are not excessively soiled.
- The plug and appliance are not wet.

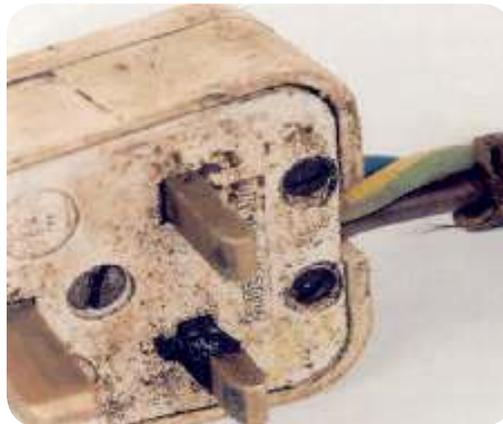

An unsafe plug

Source: HSG107 *Maintaining portable and transportable electrical equipment* (2nd ed.), HSE, 2004

## Formal Visual Inspection

Routine user checks should be backed up with less frequent formal visual inspections in some instances. These formal checks verify that the equipment appears to be in a safe condition. Formal visual inspection often requires dismantling of the equipment – usually the plug – to check that connections are still secure and that the correct fuse (if present) is fitted.

Formal visual inspection should be carried out by a competent person, i.e. someone with the appropriate training, knowledge and experience.



Formal inspection should uncover unsafe conditions, such as the fuse in this plug, which has been disabled by wrapping it in tin foil

Source: HSG107 *Maintaining portable and transportable electrical equipment* (2nd ed.), HSE, 2004

## Combined Inspection and Testing

The main limitation of visual inspection is that there are certain unsafe conditions that can arise with electrical equipment that cannot be detected visually.

Deterioration of the insulation and defective earth pathway are two of these unsafe conditions.

In many instances it is, therefore, appropriate to carry out a routine combined inspection and testing to verify the safe condition of electrical equipment. The visual inspection element of this combined inspection and testing is usually the same as the formal visual inspection already outlined. The testing element often consists of plugging a portable electrical appliance into a portable appliance test meter which runs the tests automatically.



A portable appliance test meter

Source: HSG107 *Maintaining portable and transportable electrical equipment* (2nd ed.), HSE, 2004

On other occasions, testing requires a detailed technical understanding of the equipment. In any event, this must be carried out by a competent person (with appropriate knowledge, training and experience).

## Frequency of Inspection and Testing

The frequency at which user checks, formal visual inspections, and combined inspection and testing should be carried out will vary depending on various factors. For example, a 110 V hand-held power tool intended for use on a construction site should be visually checked by the user once a week, formally visually inspected once a month and given a formal combined inspection and test once every three months.

### TOPIC FOCUS

Factors that influence the frequency of inspection and testing include:

- Legal standards and codes of practice.
- Type of equipment and whether or not it is hand-held.
- Manufacturers' recommendations.
- Initial integrity and soundness of the equipment.
- Age of the equipment.
- Working environment in which the equipment is used (such as whether it is wet or dusty) or the likelihood of mechanical damage.
- Frequency and duration of use.
- Foreseeable abuse of the equipment.
- Effects of any modifications or repairs to the equipment.
- Analysis of previous records of maintenance, including both formal inspection and combined inspection and testing.

## Records of Inspection and Testing

Records should be kept of formal visual inspections and tests: as proof of completion and so that a history of the item's condition and defects can be maintained for future reference. It is common practice to fix a test sticker or label to an item after inspection or testing to indicate when the next inspection or test is due, and retain a register of the test results. In order to achieve this, it may be necessary to give each item of equipment an identification number. Controls will also be needed to ensure that unauthorised electrical equipment is not brought into the workplace and put into use without first being registered and tested – equipment as simple and commonplace as a kettle has been responsible for workplace fatalities.

All maintenance programmes showing the periods for inspection and testing should also be kept as formal records, including records of the findings and work carried out. Checking systems should be regularly monitored to ensure that inspections and tests are completed on time and that any rectifications or replacements are carried out appropriately.

These records often form an inventory of items, especially portable appliances. Trends can be monitored to ensure that the correct items of equipment are selected and used in the right places, and regular incidents of fault or breakdown can indicate incorrect selection and use. For portable appliances, formal records are often supported with tags, labels and colour-coding of items to indicate conformity with the inspection and testing regime.

## Advantages and Limitations of Portable Appliance Testing

**Advantages** include the:

- Detection of faults not visible to the eye.
- Early removal/repair of unsafe equipment.
- Demonstration of legal compliance.
- Trends or patterns of faults that may be spotted.

**Limitations** are that:

- It provides proof of safety at one moment in time only.
- It does not ensure safe use or prevent misuse.
- Items may be missed and then remain untested.
- It cannot be applied to all equipment (e.g. computers).

### Legal Standards

- ILO C155 – Occupational Safety and Health Convention, 1981 (No. 155).
- ILO R164 – Occupational Safety and Health Recommendation, 1981 (No. 164).

### STUDY QUESTIONS

3. Explain earthing.
4. Identify the difference between a fuse and a circuit breaker.
5. Identify the difference between switching off and isolation.
6. Identify the protection offered by a reduced low-voltage transformer used to provide power to hand tools.
7. Outline the safety device that should be used when mains-supplied electric hand tools are being used outdoors.
8. Identify the user checks that might be carried out before an item of electrical equipment is used.
9. Identify the first step in treating a victim of electric shock.

(Suggested Answers are at the end.)



# Summary

---

This element has dealt with some of the hazards and controls relevant to the use of electricity in the workplace.

In particular, this element has:

- Described the risks of electricity as electric shock, burns (both direct and indirect), fire and explosion, arcing, and secondary effects.
- Explained the range of effects of electric shock from mild discomfort and muscle tremor; uncontrollable muscle contractions and respiratory failure, to VF, cardiac arrest and severe burns; and how the severity of injury is influenced by several factors, such as system voltage, duration of contact, pathway through the body, body resistance, contact surface area, environmental factors and frequency.
- Outlined the reasons why portable electrical equipment is often involved in electrical accidents, because it is often unsuitable for the job being done, misused, and not inspected or maintained.
- Described the various protective systems that can be used for electrical equipment, such as fuses (a weak link in the circuit), earthing (a low-resistance path to earth for fault current), isolation of supply (cutting the power), double insulation (two layers of insulation), RCDs (sensitive, fast-acting trips), and reduced and low voltage (reduced shock current).
- Outlined the importance of restricting work on electrical systems to competent persons only.
- Outlined the use of SSWs to control the high risks associated with work on, or near, electrical systems.
- Described an emergency procedure to be put in place if a person is injured in an electrical incident.
- Explained the importance of user checks, formal visual inspections and combined inspection and testing that can be used to ensure the safety of all electrical installations, equipment and appliances including portable appliances.

# Practical Assessment Guidance

## Worked Example

NEBOSH has included a worked example of Unit IG2 practical assessment in their Assessment Pack so that you can see what you are aiming for. It is duplicated as a worked example here.



### Unit IG2: Risk assessment

#### Part 1: Background

Learner number: 12345678

Learner name: A. N. Illustration

**Write in their own words (in their own words) and number of workers. You must then go on to give a description of the cover with the appropriate level of detail. You must also describe the work to be risk assessed eg, vehicle site and anything else that you consider relevant (approximately 150 to 250 words).**

My organisation is International General Garage Ltd (known as IGG Ltd), which is based in Ambedkar Country and employs 24 workers.

IGG Ltd is a medium sized garage with offices, vehicle repair shop and paint spray booth. The business does a lot of repairs and maintenance on work vans and body repairs on cars that have been involved in accidents for insurance companies. Servicing is also carried out for members of the public. Typical activities undertaken include moving spare parts from the stores to the workshop, engine repairs, activities relating to servicing, body repair, painting, wheel, spray booth activities (including the use of paints that are solvent based). The garage operates from 9am to 5pm on weekdays and is closed at the weekends. Workers are only required to work 7 hours per day so there are staggered start and finish times in place.

The risk assessment will cover the garage and spray booth activities; the office area has a separate risk assessment. The Finance Director (who reports directly to the Managing Director) has direct responsibility for health and safety.

**You must now give a brief outline on how you completed the risk assessment (approximately 250 words).**

I started by looking to see if the ILO had any Codes of Practice relating to garage work (which there weren't). The HSE's website had lots of resources, for example, 'Health and safety in motor vehicle repair and associated industries' (HS3261) <http://www.hse.gov.uk/pubns/priced/hs3261.pdf> was a good source of information.

After looking at sources of information, I then went around the workshop and talked to the people who were doing the job. They gave me information that some of the workers were just a casual operator. For example, a lot of the workers didn't know that there were dust masks available or the reasons why these should be worn.

I also checked the accident book to see what types of incidents had occurred over the last 12 months and whether any of these incidents were occurring. I also checked the records for work-related injuries, to see if there were any recurring themes for health.

Page 1 of 18



When assessing the control measures, I also referred to some of the HSE's Approved Codes of Practice or Guidance documents. For example, when looking at control measures for dust in the workplace, I referred to 'Dust in the workplace: General principles of protection' (Guidance Note L104) (2nd edition) <http://www.hse.gov.uk/pubns/l104.pdf>.

\* If you're worried about confidentiality, you can invent a few names and locations for your organisation but, all other information provided must be factual.

Page 2 of 18



## Part 2: Risk Assessment

Learner number: 12345678

Learner name: A.N. Illustration

### 5. Risk assessment

Organisation name: IGB Ltd  
 Date of assessment: 04 July 2019  
 State of risk assessment: Workshop and spray booth

Hazard category and hazard	Who might be harmed and how?	What are you already doing?	What further control/actions are required?	Timescale for further actions to be completed (refer to J)	Responsible person's job role
1. Aerosols 2. Dust - high concentrations of process dust	All workers, customers and others using the operation.  High concentrations of process dust are always present from the machine and frequent activities being carried out. Since there is no dust extraction, people breathe in hazardous dust, which can cause anything from short term irritation to long term chronic health conditions.  People can also get the infrared light on their skin which can cause dermatitis, in this case causing eye irritation and damage to vision.	0. Dust extraction  Dust masks available but it is not mandatory that these are worn.	1. Enclosed area to be set up for sanding/ grinding operations including that will include a suitable local exhaust ventilation system.  2. Purchase of local exhaust extraction systems.  3. Use of face masks in conjunction with extraction systems (i.e. enforcement of law 30 - purchase of).  4. Conduct RPE if the above do not fully control the hazard.  5. Current dilution ventilation system to be inspected and repaired if necessary.  6. Maintenance programme for all ventilation systems.	6 months  1 month  1 month  To be assessed on completion of the enclosure  1 month  6 months	Workshop Manager (tasks 1, 3, 4, 5, 6, 8, 9, 10, 11, 12, 14 and 15)  Thames Director (tasks 2, 4, 7, 10, 14, 15 and 16)  Sales Manager (tasks 3, 13 and 14)

Page 3 of 16



Hazard category and hazard	Who might be harmed and how?	What are you already doing?	What further control/actions are required?	Timescale for further actions to be completed (refer to J)	Responsible person's job role
	accidentally pulled over if provided with handles from conform related handles.		7. Improved housekeeping - purchase of least two suitable vacuum cleaners to keep dust in the general workplace and office areas to a minimum.  Safe system of work (SSOW) to be introduced i.e. 8. Current systems reviewed.  9. Updated to do operation of enclosure. Note: the workshop manager must consult with the workforce when producing the safe system of work.  Training programme to be set up for all workers undertaking these activities. 10. On bed practices for keeping dust levels to a minimum.  11. On the safe system of work.  12. Personal hygiene education for those workers undertaking these activities eg dust ingestion or inhaled from hand to mouth contact.  Improved welfare arrangements and PPE systems 13 - 15. 13. First aid arrangements for those doing sanding/ grinding operations and guards if appropriate.	6 months  1 month  On completion of the enclosure  3 months  Once SSOW has been drafted off  1 month  1 month	

Page 4 of 16



Hazard category and hazard	Who might be harmed and how?	What are you already doing?	What further controls/actions are required?	Timescale for further actions to be completed (where applicable)	Responsible person's job role
			14. Construction of segregated enclosed area of the charging room for the noise of dual covered overheads. 15. Improve washing facilities in the charging area (consider installing showers). 16. Look into the possibility of setting up a health surveillance programme for all affected workers.	6 months  1 month  6 months	
Work equipment having cables and/or components	<p>Technicians could be injured or there is a possibility of death should one of the lifts/jacks for raising a vehicle or component fail or collapse.</p> <p>Workers undertaking maintenance of the equipment if the equipment malfunctions during maintenance. This could cause a risk of injury from falling or measures or work area control not being</p>	Some specialist maintenance of lifting equipment	1. Implement a plan based on programme for all lifting equipment. 2. Improve and condition of all current lifting equipment. 3. Check that the make of the piece of work lifting equipment. 4. Checks need to be made that all lifting equipment is marked with safe working load (SWL) information. Where SWL is not marked on the equipment, it has been marked off over time, this information must be marked on the equipment.	1 month  1 month  1 month  1 month	Finance Director and Warehouse Manager  Warehouse Manager  Finance Director  Warehouse Manager

Page 5 of 10



Hazard category and hazard	Who might be harmed and how?	What are you already doing?	What further controls/actions are required?	Timescale for further actions to be completed (where applicable)	Responsible person's job role
Electricity Portable electrical equipment (PEE) - T-socket equipment in the workshop and office Arms and connect electric installation for workshop	<p>Any worker using faulty equipment or electrical installation or using or plugging in equipment in faulty socket.</p> <p>The harm most likely to be caused are burns resulting from shocked and/or electrical burns, and fire if a live wire is exposed or death (electrocution).</p>	<p>The electrical installation for the garage has recently been checked by a competent electrician. Next check has been planned for three weeks (unless there are sign from changes in the installation).</p> <p>The main switchboard has a built in residual current device.</p> <p>A risk assessment procedure is in place and annual checks are carried out on all PEE equipment marked for replacement.</p> <p>All workers have received training in good practice and the use of the procedure should defective equipment be found.</p> <p>Some shock mats have been purchased and the raised where possible by low voltage mats to limit for inspecting vehicles.</p> <p>Trained first aiders are available who can deal with minor electric shocks etc.</p> <p>All workers aware of emergency arrangements for electrical related incidents.</p>	<p>RCD control will be no further action required at the moment.</p>	N/A	N/A

Page 6 of 10



Hazard category and hazard	Who might be harmed and how?	What are you already doing?	What further control actions are required?	Timescale for further actions to be completed (RRC 5.2)	Responsible person's job role
<p>Flammable substances</p> <p>Use of petrol and fuel</p>	<p>Mechanics who are handling these substances on a daily basis</p> <p>Flammable substances known to be sent down drains so they could cause occupational health and/or environmental concerns.</p>	<p>Overalls are supplied to all mechanics</p> <p>Overalls are cleaned on a regular basis by an outside contractor</p> <p>Skills training and all workers trained in this</p> <p>Specialised containers used for disposal of waste oil etc. and used regularly</p>	<p>See actions 10, 16 and 17 above in part (see fire and gas notes)</p> <ol style="list-style-type: none"> <li>1. Review all the working areas for maintenance</li> <li>2. Review monitoring systems in areas, gases are being monitored relevant areas</li> <li>3. Review systems for disposal of used gases</li> <li>4. Check status of the waste disposal contractor who removes the waste oil etc. to ensure they are given from site</li> <li>5. Training for mechanics on petrol spill and disposal when handling these substances</li> </ol>	<p>1 month</p> <p>2 months</p> <p>1 month</p> <p>2 months</p> <p>3 months</p>	<p>Store Manager (actions 1 and 2)</p> <p>Workshop Manager (actions 3 and 5)</p> <p>Finance Director (action 4)</p>
<p>Safety movement of people and vehicles</p> <p>Moving vehicles from the parking area to the workshop area (the new loading area of the site)</p>	<p>All workers on site especially mechanics and customers</p> <p>Tractor from the car park be reverse and could include risk to it</p>	<p>Separate parking area and provided for customers</p> <p>Provision walkways are clearly marked (these included barriers between the walkways and road)</p> <p>Site speed limit and signs</p> <p>The workshop and parking areas are well lit</p> <p>All mechanics and those moving vehicles have a full driving licence</p>	<p>Review system for moving vehicles around the work area and between the workshop and spray booth eg. one person pushes the vehicle in and out of the opening and another stands at the opening and will ensure that vehicle cannot drive out</p>	<p>1 month</p>	<p>Workshop Manager</p>

Page 7 of 18



Hazard category and hazard	Who might be harmed and how?	What are you already doing?	What further control actions are required?	Timescale for further actions to be completed (RRC 5.2)	Responsible person's job role
		<p>Rubber matting in place to cover all the areas that may become frozen during the winter months</p>			
<p>Noise</p> <p>Exposure to noise from workshop activities</p>	<p>Mainly the mechanics and others who work behind panels in the workshop area. The proposed unenclosed exposure to noise at 80 dB will occur time to time (NFI)</p> <p>The workshop is noisy at certain times as you have to make your voice heard when holding a conversation eg. carrying gas and machinery running at the same time</p>	<p>A noise assessment has not carried out when the workshop was first set up (15 years ago)</p> <p>A recent review (May 10) of the proposed personal hearing protection (PPE) in use has been carried out. As part of this the old factory PPE (earplugs) hearing protection was replaced. Suitable hearing protection has been issued to all relevant workers. All relevant workers have been trained in the correct use of the PPE</p> <p>There is a planned personal hearing assessment programme in place for all operators</p> <p>All workers are trained in reduction on the effects of noise on human health</p> <p>The effects of noise will be reviewed in the next 6 to 12 months</p>	<ol style="list-style-type: none"> <li>1. Install additional barriers around some of the noisier areas and taking sound absorbing materials</li> <li>2. Look into the possibility of setting up a hearing surveillance programme for relevant workers</li> <li>3. Purchase a noise noise meter</li> <li>4. Arrange noise meter training for the Workshop Manager</li> <li>5. Carry out a simple noise survey</li> <li>6. Use the British HSE noise calculator to find out exposure levels. Help choose the appropriate hearing protection for him</li> <li>7. Implement additional control measures if required following noise survey</li> </ol>	<p>6 months</p> <p>6 months</p> <p>1 month</p> <p>2 months</p> <p>8 months</p> <p>3 months</p> <p>To be confirmed following noise survey</p>	<p>Finance Director (actions 1, 3 and 7)</p> <p>Workshop Manager (actions 4 and 5)</p>

Page 8 of 18



Hazard category and hazard	Who might be harmed and how?	What are you already doing?	What further control/actions are required?	Timescale for further actions to be completed (if relevant)	Responsible person's job role
Slips and trips, Spillage of oil and motor fuel, oil, grease, building materials, building rubble etc.	All workers, workmen and other visitors to site.  Cuts, bruising, muscle strain/exhaustion, broken tools, lost equipment, pollution or blockage of main, walkways, or other surfaces, protruding metal objects etc.	Designated sweepers (dedicated by job or particular area).  Designated storage areas, where chemicals are used to indicate areas that must be kept clear of all items.  Good housekeeping (workers take away unused equipment, etc. in the designated areas).  Spill kits placed and all workers have been trained in their use.  When the inspection pits in use, the areas are cordoned off by orange barriers for those working near the area.	Arrange for them to be disposed of, or landfilled.  System for random housekeeping checks. Will be ongoing.  Check whether additional safety measures could be installed to prevent any spillages or leaks.	1 month  1 month  1 month	Workshop Manager, MVA, etc.
Work above height	Anyone working in or around the excavation pit.	When the inspection pits in use, the areas are cordoned off by orange barriers for those working near the area.	Provide a mobile phone for workers, so that they can call out without both sides of the impediment when working at ground level.	2 months	Workshop and Safety Managers
Working in and around the excavation pit	Falls, injuries include cuts, bruising, fractures, head, internal injuries, severe back pain, severe loss of fingers and ability to be lit, changing and moving the worker being in constant contact with poles, top of metal cage, or other people able to work either side of the cage, or nearby on site.	Good safety practice, all workers and visitors to the site are trained in the use of the impediment.  The use of orange barriers to restrict access to the excavation pit.  The use of orange barriers to restrict access to the excavation pit.  The use of orange barriers to restrict access to the excavation pit.  The use of orange barriers to restrict access to the excavation pit.  The use of orange barriers to restrict access to the excavation pit.  The use of orange barriers to restrict access to the excavation pit.  The use of orange barriers to restrict access to the excavation pit.	Add the bridge into the maintenance schedule – needs to be inspected at least every six months.  Arrange for workers to be trained in how to use the bridge safely.	2 months  2 months following purchase of the bridge	

Page 16 of 16



Hazard category and hazard	Who might be harmed and how?	What are you already doing?	What further control/actions are required?	Timescale for further actions to be completed (if relevant)	Responsible person's job role
Working at height	Anyone working in the workshop.	Access equipment for use when working in the excavation pit, including ladders, scaffolding, etc. is regularly inspected and maintained.  The workshop manager regularly inspects the use of access equipment.	Changes to the system of work to include the use of access equipment to be done before work begins.	1 week	Workshop and Safety Managers
Working in the vicinity of commercial vehicles	Falls, injuries include cuts, bruising, fractures, head, internal injuries, depending on the weight of the vehicle falling.	All spraying is carried out in the enclosed spray booth.	Assessment of risk to be added to the workshop schedule.	1 week	
Respirable dust	Mainly the workers in the spray booth, but other workers could also be affected if they enter the booth when spraying operations are taking place.	Designated workers used for spraying tasks.  Workers in the immediate vicinity of the equipment removed and all the equipment covered.  Air inlet compressor located away from possible source of contaminants.  Separate and filtered air intake during spray paint.	The clearance line from the spray booth is not suitable for the maintenance of the equipment.  Need date for cleaning the booth, separate down draught unit down every three months.	1 week  1 month	Workshop Manager  Workshop Manager
Inhalation of dust containing asbestos	Workers exposed to the spray paint and dust in the spray booth, but other workers could also be affected if they enter the booth when spraying operations are taking place.	Designated workers used for spraying tasks.  Workers in the immediate vicinity of the equipment removed and all the equipment covered.  Air inlet compressor located away from possible source of contaminants.  Separate and filtered air intake during spray paint.	Need date for cleaning the booth, separate down draught unit down every three months.  Check whether a personal protective programme for asbestos is in place (check the age requirements).	1 month  1 month	Workshop Manager  Health Director

Page 16 of 16



Hazard category and hazard	Who might be harmed and how?	What are you already doing?	What further control actions are required?	Timescale for further actions to be completed (where applicable)	Responsible person's job role
		All safety boots supplied are regularly checked and maintained by competent workers (Workshop Manager checks and maintains records).			
Vibration Grinding and grinding activities	Workers in the workshop area.  Because use of a class of D-type hand-held tools such as die cutters, sanders and grinders could lead to hand-arm-vibration (HAV) conditions such as vibration white finger.	<p>Vibration programme in place for all hand held occupations, including shoring equipment.</p> <p>All workers are trained in the use of vibration hand-held tools.</p> <p>There is an inventory rule that only tools that have been designed to reduce the risk of HAV should be purchased.</p>	<p>Monitor the system to be sure it remains functional and any issues are resolved before workshop time.</p> <p>Look at notes to ensure workers are trained between activities.</p> <p>Look into setting up a health surveillance programme for all tool users.</p> <p>Look for tools to be sold at least a year on the effects of vibration from hand-held tools.</p> <p>Formalise the purchase policy to ensure that only tools &amp; equipment purchased to reduce the risk of HAV.</p> <p>Evaluation of the level of our workers' exposure to vibration should be carried out to ensure that the daily exposure and average values are not being exceeded.</p>	<p>1 month</p> <p>1 week</p> <p>6 months</p> <p>6 months/1 ongoing</p> <p>6 months</p> <p>1 month</p>	<p>Workshop Manager</p> <p>Workshop Manager</p> <p>Finance Director</p> <p>Workshop Manager</p> <p>Finance Director</p> <p>Finance Director and Workshop Manager</p>



Hazard category and hazard	Who might be harmed and how?	What are you already doing?	What further control actions are required?	Timescale for further actions to be completed (where applicable)	Responsible person's job role
Health, safety and work environment: exposure of temperature Working on air conditioning systems	<p>Mechanics working on individual ventilation systems.</p> <p>If health conditions likely to be affected are:</p> <ul style="list-style-type: none"> <li>Headaches – caused by air that eye contact with refrigerant liquid or gas.</li> <li>Acquaintance – if gas escapes in sufficient quantities into a confined working space.</li> <li>Because when the gases from the motor decommission of the refrigerant in the gas is exposed to high temperatures.</li> </ul>	<p>Use of competent workers.</p> <p>Safe system of work in operation that all workers are trained in and work in this includes identification of refrigerant before work commences.</p> <p>Suitable PPE issued to all workers involved.</p> <p>Suitable arrangements in place to dispose of waste refrigerant.</p>	<p>Review each worker with the British L5011 (SA) working with refrigerant using systems guidance leaflet (HSE244): <a href="http://www.hse.gov.uk/l5011/leaflet5011.pdf">http://www.hse.gov.uk/l5011/leaflet5011.pdf</a> so that they are aware of what could go wrong and how to keep it from going wrong.</p>	<p>1 week</p>	<p>Workshop Manager</p>
Risk Workshop activities such as welding and other hot work, using tools, faulty electrical equipment, handling tools and other equipment e.g. submersible	<p>All workers and other visitors to the site could either suffer burns and/or smoke inhalation injuries. The workshop activities should be stopped if the building and can't be moved.</p>	<p>There is a detailed fire risk assessment in place that covers all of these issues.</p> <p>Preventative control measures are in place along with control measures to mitigate the danger should a fire break out. These are regularly tested and maintained.</p> <p>Emergency procedures are tested regularly (over the drill carried out by the site staff).</p>	<p>No further action required.</p>	<p>N/A</p>	<p>N/A</p>



Part 3: Prioritise three actions and justification for the selection

Learnor number: 12345678

Learnor name: A. N. Example

You must rank the three highest priority/most urgent actions and justify your choice. Your justification must include most, legal and financial aspects (500 to 700 words), consideration of likelihood and probable severity of injury, health and loss (150 to 250 words), description of how effective each action is likely to be in controlling the risk (250 to 350 words).

The risks that I am prioritising are:

1. Purchase of mobile bridge for low maintenance to be able to safely access both sides of the hooped on it when working on ground level. (Lowest category/lowest likelihood)
2. Revised arena hoisting for handling/lighting operations, including that will include a mobile robot/robotic work/lift system. (Lowest category/lowest likelihood)
3. Purchase of vehicle driver workstation systems (ground control) for vehicle driver. (Lowest category)

IGG1 has a responsibility to protect all workers. Our workers come to work to earn a wage, not to be put at risk of being ill, injured or in the future because of the work that they do for us. Some of the health conditions that are the most feared amongst the workforce will have a major impact on the lives of the workers and their families. Long term occupational health and safety should have a major impact on our workers' mental health. The mental health of other workers could also be affected if they are witness to any incident in their workplace.

These risks could be broken down into three categories. Some associated with:

- injured workers, peak performance, equipment, worker safety, medical costs, lost work and time etc.
- no equipment and/or infrastructure, such as for example if control is lost over a vehicle being moved around the workshop and this subsequently crashes through one of the support walls etc.
- costs associated with enforcement actions.

Visible enforcement actions that IGG could receive include being required with prohibition (stopping all work on a particular activity) or improvement (meaning that it may need to be put right within a certain period of time) followed up by these activities by the regulator. This would obviously have a massive financial impact on the organisation if these activities could not continue.

There are also some financial risks that IGG need to consider under the LJO Convention 101 and Revised Declaration (R101). The Convention/Declaration requires employers to make sure that machines and equipment are safe to use. Specifically, the LJO Convention Safety and

Page 13 of 16



results in the use of machinery (section 2.5) requires that all lifting equipment and accessories should be maintained, inspected and marked at appropriate intervals. Failure to do so could have serious consequences, including work stoppages and/or fines.

The LJO Convention 101 and Recommendation (R101) require employers to make sure that processes are reasonably safe. The LJO code of practice (2018) Safety in the use of shoring and work platforms, which on the appropriate matters, that employers need to make to provide workers with the safe and stability of shoring. The LJO Code of Practice, however, and not least in occupational accidents and diseases' require employers to report cases of occupational accidents to our country's health and safety regulator.

The employer could also find that civil claims from workers made ill by their work activities could be made. Some of these claims may be made some years after the worker has left IGG for employment. The likely amount of compensation payable for civil claims can be substantial. In addition to this legal cost, additional costs could also be likely to be very high. It would also be difficult to manage if these costs should not eventually come from the insurance company.

If anything goes catastrophically wrong, R101 regulation could make a serious fall which could result in loss of business (especially the mobile work)

and food and storage:

1. The likelihood of injury occurring from working in and around the inspection pit is quite high. This is due to the hooped on it being in regular use and movement of equipment in the area. The severity of the risk occurring could be fairly serious. Injuries could lead to minor permanent injuries and/or being signed off as being slightly more serious injuries such as fractures or heavy workers' compensation costs or even fatal injuries. The severity will depend on what height the worker falls from, from the top of the pit (over an eight foot drop) or fall from the work steps.
- 2 and 3. With hazardous activities like this, the workers will become ill through inhaling the hazardous substances. The likelihood of ill health occurring is quite high for our initial set. Most of the workforce and the general public are currently exposed to our air these operations are not carried out in an enclosed area. Inhalation of dust could cause occupational asthma, breathing in dust over a prolonged period could also cause occupational cancer.

Controlling the risk:

1. The bridge will improve access problems in the arena. The installation of a bridge over workers lead to people not being able to get to the area where the obvious risks associated with it. I have given a list of some of the more advanced specialised pieces of equipment that nobody in the business has used before. The plan will need to secure a supplier and then arrange a delivery date. It is hoped that this project will be completed within the next month or two.
2. The dust extractors will have a major impact on the amount of dust in the work area. It will help the dust from spreading across all work areas. I have given a list of some of the more advanced specialised pieces of equipment that nobody in the business has used before. The plan will need to secure a supplier and then arrange a delivery date. It is hoped that this project will be completed within the next month or two.

Page 14 of 16



2. This action will also have a major impact on the majority of the workforce. I have given a timeframe of within one month for the on tool extraction systems due to the immediate impact that will have on reducing the amount of coal in the area. The budget for the purchase of the systems needs to be agreed with the Managing Director.

Page 15 of 16



Part 4: Review, check and communicate

Learner number: 12345678

Learner name: A. N. Example

**You must now give a review date for your risk assessment and say why you have chosen this date (16 to 50 words).**

Company policy is to review risk assessments at least every 12 months. I therefore set the review date for 12 months time – 20 July 2020.

**You must now explain how the risk assessment findings will be communicated (including who needs to know the information) (167 to 450 words).**

I will arrange a meeting with the Finance Director to go through and agree the actions in the risk assessment. I will then provide a summary of the findings and actions for the Workshop and Store Manager (these will be emailed initially with follow-up meetings if required). The findings of the risk assessment will be included in the next available issue of the site where I will also review the progress on the actions that are to be taken. A summary of the risk assessment and actions to be taken will also be posted on the company intranet that all workers have access to.

**You must now explain how you will follow-up on the risk assessment to check that the actions have been carried out (120 to 150 words).**

I will set diary reminders for roughly 10 days before the action is due to be completed. I will speak to the responsible person for each of the actions to find out the progress against each action. Should the action not be on target for completion I will find out the reasons why, e.g. is it down to finance or other resource issues such as worker time to complete actions. If any actions look like they are not going to be completed on time I will speak to the Finance Director to seek additional resource availability for the action. Actions that are very overdue (i.e. completion is more than six months late) will be referred to the Managing Director via the Finance Director.

Page 16 of 16

Please do not copy any part of this worked example as this would constitute plagiarism that would be investigated by NEBOSH and dealt with in line with their malpractice policies.

## Unit IG2

---

### Final Reminders



Now that you have worked your way through the course material, this section contains some reminders to help you with the practical assessment. It offers advice on how to approach the assessment and has some useful hints and tips.

## Summary Guidance on the Practical Assessment

The practical assessment requires you to carry out a risk assessment in your workplace. There are several parts to this assessment as shown in the diagram below:



You must record your assessment on the standard form supplied by NEBOSH in its online Assessment Pack. You can download this form from their website. Forms can be completed by hand or electronically. However, we recommend that you complete the form electronically.

**Make sure that you include all of the information that is requested in italics at the top of each and every box.**

### Part 1 – Description of the Organisation and Methodology Used





**Unit IG2: Risk assessment**

**Part 1: Background**

***You must give the organisation's name and location and number of workers. You must then go on to give a description of the main activities/products/services provided and how you will conduct the risk assessment with reference to any standards that you consider relevant (approximately 250 to 300 words).***

***You must now give a brief outline of how you conducted the risk assessment (approximately 200 words).***

\* If you are worried about confidentiality, you can invent a false name and location for your organisation but all other information provided must be factual.

Examiner number: \_\_\_\_\_
Examiner name: \_\_\_\_\_
Page 1 of 8

### Description of the Organisation

Ordinarily the workplace that you choose to describe would be the organisation that you work for. It needs to be large and complex enough to present a good range of hazards.

You can provide a false name and/or location for your organisation if you like, to protect the identity of the organisation and maintain confidentiality.

In the first box, include the organisation’s name and location (even if they are fictitious). Include the number of workers and the shift patterns that are worked. Give a good general description of what the organisation does and the site layout so that the examiner can picture the kind of workplace, the products or services involved, and the sorts of activities that are likely to be carried out there.

NEBOSH recommends that you write 150–200 words for this section.

### Methodology Used

The second box requires you to explain how you carried out the risk assessment (your methodology).

You should include things such as the sources of information that you consulted, who you spoke to, and how the hazards and controls were identified.

NEBOSH recommends that you write 200 words for this explanation.

### Part 2 – Risk Assessment



Part 2: Risk Assessment

Organisation name:  
Date of assessment:  
Scope of risk assessment:

Hazard category and hazard	Who might be harmed and how?	What are you already doing?	What further controls/actions are required?	Timescale for further actions to be completed (date)	Responsible person's job title

Location number:

Location name:

Page 2 of 8

The form appears self-explanatory but it needs to be completed by carefully reading and following the NEBOSH guidance.

Start by putting the organisation name, risk assessment date and risk assessment scope (where the assessment was carried out) in the relevant places at the top of the form.

### Hazard Category and Hazard

You need to identify **at least 10** significant **hazards**. These must come from **at least 5** of the **hazard categories** that are dealt with in the Unit IG2 course. The hazard categories are:

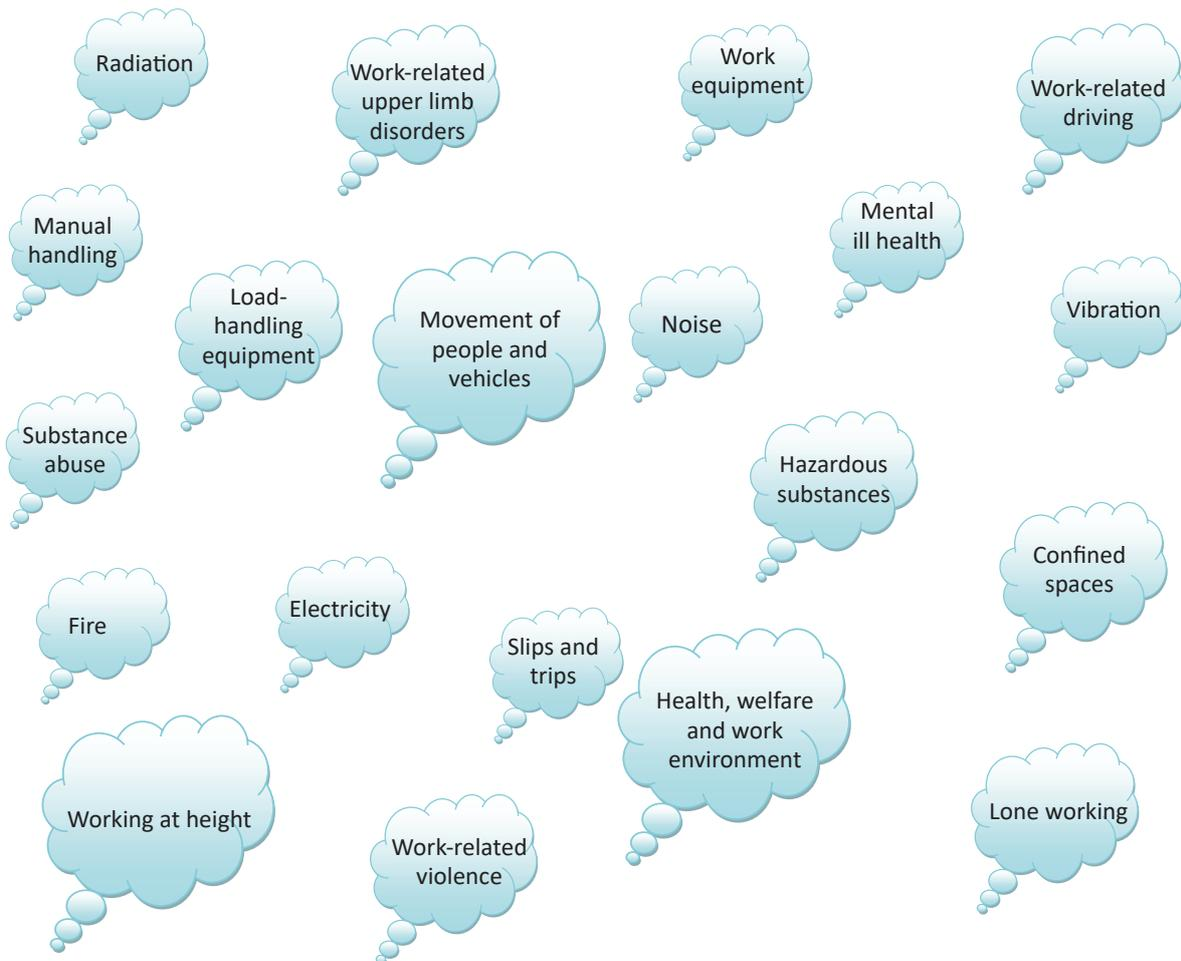

There are 20 categories and you must pick your hazards from 5 or more of them.

Remember that hazards are 'things that have the potential to cause harm'. Some of your hazards may be very poorly controlled and some of them may be very well controlled. The key thing is that all of your 10 or more hazards must have significant potential to cause harm in the form of either physical injury and/or ill health.

As you complete the first column of the form, remember to put the hazard category first and the hazard second. For the hazard category, simply select the name of the topic from the above list of 20. For the hazard itself, identify it by referring to the specific activity or area where it exists.

The key things to remember here are:

- There must be at least 10 hazards.
- The hazards must come from at least 5 different hazard categories.
- The category is identified in the column first followed by the hazard – which is identified using a little information so the examiner can see the specific nature of the hazard.

Do not identify:

- Fewer than 10 hazards.
- Trivial or fanciful hazards.
- Hazards from fewer than 5 hazard categories.

### Who Might be Harmed and How?

The second step of the risk assessment process is to identify **who** might be harmed and **how** for each of the specific hazards that have been identified in column 1.

Identify broad categories of people such as workers, contractors, visitors and members of the public. Identify groups of people or individuals who might be more vulnerable to the hazard in question, such as new and expectant mothers, young people, lone workers, people with disabilities, etc.

You must write a short description about how these people might be harmed. This should include information about when and how they are exposed to the hazard and the type of harm(s) that might occur.

### What Are You Already Doing? and What Further Controls/Actions Are Required?

The third step in completing the risk assessment is to identify the control measures that are currently in place to manage the risk created by each hazard and, where these control measures are inadequate, to identify the additional control measures necessary to manage the risk down to an acceptable standard.

There are two columns to record this information, column 3 and 4 on the Part 2 form. These two columns work in unison. So, if very little is currently being done to manage the significant risk created by a particular hazard then the expectation is that additional control measures are required.

Some of the control measures will be physical things such as guards on machinery and LEV systems to extract hazardous airborne contaminants. Many of the control measures will be administrative or procedural, such as the SSW for a particular maintenance task and maintenance programmes on items of equipment.

Once you have described all of the existing control measures for all of the hazards that you have picked out for attention in your assessment, you then need to describe the additional controls required. In column 4 you need to briefly describe the additional control measures that need to be introduced to further control the risks created by your specific hazards.

Please note that the risk assessment methodology used in the practical assessment has no requirement for risk rating and it makes no mention of likelihood or severity scoring.

### Timescales For Further Action to be Completed and Responsible Person's Job Title/ Role

The last step in completing the Part 2 risk assessment form is to allocate a timescale and a responsible person to each of the additional control measures identified in column 4.

When you are filling in the 'Timescales' column, make sure that you write in lengths of time and not deadline dates.

You can use any timescale you like but do not put deadline dates (such as 30 September 2020) and do not write 'as soon as possible'.

When you are allocating timescales think about two separate issues:

- What is the current level of risk presented by the hazard and how urgently is the further action required?
- How easy is it to carry out the additional action from a practical point of view?

When you are allocating responsibilities for each of the further actions required, you must do so on the basis of people's job roles or job titles. Bear in mind that some actions can and will be allocated to junior managers, others to middle managers and some to senior managers. The nature of the action will determine which level, within the organisation, the responsibilities are allocated.

### Part 3 – Three Priority Actions



#### Part 3: Prioritise three actions and justification for the selection

You must pick the three highest priority/most urgent actions and justify your choice. Your justification must include moral, legal and financial arguments (200 to 250 words), consideration of workload and protective measures or control, a health action plan (250 to 300 words), description of how effective each action is likely to be in controlling the risk (200 to 300 words)

Specimen

Examiner number:

Examiner name:

Page 5 of 8

## Prioritise Three Actions and Justification for the Selection

You must pick what you think are the three most urgent or highest priority actions from your Part 2 risk assessment form. You must then justify your three choices by explaining, in detail, the:

- Moral, legal and financial reasons for taking these three actions.
- Current risk level presented by each of the relevant hazards as they are currently controlled (with reference both to likelihood and severity of outcome, and the foreseeable injury or ill-health effects).
- Effectiveness of each proposed action in controlling the risk with some justification for the timescale allocated.

Your first task is to select the three most urgent/highest priority actions. All three actions must come from column 4 in Part 2 of the risk assessment form: 'What further controls/actions are required?'. They can come from three completely separate hazards/hazard categories, all from the same hazard/hazard category, or two from one hazard/hazard category and one from another. However, it is probably a good idea to pick actions from three different hazards, even if those hazards all come from the same hazard category.

- Start by telling the examiner which three actions you have picked as urgent.

You must then justify your three choices by clearly explaining the moral, legal and financial reasons for taking the actions required. You must make use of all three arguments in your justification.

Importantly, when you are making your legal arguments, you must refer to the specific legislation that is relevant to the hazard category/hazard in question. For the International General Certificate course (IG), you must use the ILO Conventions, Recommendations and/or Codes of Practice that are relevant to the hazard category/hazard in question.

NEBOSH indicates a word count of 500–700 words for this section.

- The next step in your justification is to explain the risk that is currently created by each hazard as it is currently controlled. This will require you to explain the number of workers exposed to each hazard, the duration and frequency of exposure, and the circumstances under which they might be exposed. You must also explain the foreseeable harm that each hazard might cause, such as the range of possible physical injuries and/or the range of ill-health effects.

NEBOSH indicates a word count of 150–250 words for this section.

- The final part of your justification requires you to explain how effective each action will be in controlling risk. You must explain the likely impact of each action, how effective you think it will be in reducing risk and why you have allocated the timescale that you have.

NEBOSH indicates a word count of 250–350 words for this section.

### Part 4 – Review, Communicate and Check



Part 4: Review, communicate and check

You must now give a review date for your risk assessment and say why you have chosen that date (10 to 50 words)

You must now describe how the risk assessment findings will be communicated (including who needs to know the information) (100 to 150 words)

You must now describe how you will follow up on the risk assessment to check that the actions have been carried out (100 to 150 words)

Specimen

Element number

Element name

Page 6 of 8

- In the first section of Part 4, you must give a risk assessment review date and explain why you have chosen that date.  
NEBOSH indicates a word count of 10–50 words for this section.
- In the second section, you must explain who you will communicate the findings of the risk assessment to and how.  
NEBOSH indicates a word count of 100–150 words for this section.
- In the third and last section, you must explain how you intend to follow up your risk assessment to check that all of the identified actions have been carried out.  
NEBOSH indicates a word count of 100–150 words for this section.

## HINTS AND TIPS

Do:

- Read all parts of the official NEBOSH guidance on the practical assessment (available from the NEBOSH website) and the guidelines in this study text before you submit your forms.
- Complete the assessment gradually rather than in a rush just before the deadline for submission.
- Read all of the relevant hazard-specific content of the course before preparing your assessment forms so that you have a good understanding of the nature of the hazard, the risk that it creates and the control measures that might be necessary.
- Carefully check your work for spelling errors and simple technical errors by double checking in the study text and online.
- Make sure that you put the right amount of work into the relevant parts of the assessment. Use the word count given by NEBOSH as an indication of how much work to do.
- Check that you have written your name and learner number on every part of every form where required.
- Check that your final document for submission (whether hard copy or electronic) contains all of the relevant parts and that you have not accidentally missed a part out.
- Look at the Worked Example published by NEBOSH which is reproduced at the end of Element 11 and is also available in the Assessment Pack from the NEBOSH website.

### HINTS AND TIPS

Do not:

- Carry out your assessment in a very restricted and low risk workplace with too few hazards.
- Ignore the information requested in italics at the top of every page of the form.
- Write a very short, incomplete introduction to your workplace or explanation of your methodology.
- Pick fewer than 10 hazards for your risk assessment.
- Pick hazards from fewer than 5 hazard categories.
- Repeat the same hazard or hazard category over and over.
- Identify the people who might be harmed by simply stating everyone for every hazard.
- Give a very brief description of the current control measures in place or the additional control measures required.
- Allocate all actions to the same person.
- Give 'ASAP' as the timescale for your actions.
- Pick priority actions that do not appear in column 4 of your risk assessment form.
- Pick low risk, trivial or well-controlled hazards for your three top priority actions.
- Write very short and unconvincing justifications for why you pick the top three actions that you did.
- Fail to identify a review date.
- Leave the organisation's name, risk assessment date or assessment scope off the Part 2 risk assessment form.
- Leave your learner number and learner name off of any parts of the form.
- Copy any parts of your assessment from any other student or from any other source. You do not want to get investigated for plagiarism and fall foul of NEBOSH's malpractice rules.
- Copy any parts of the Worked Example (mentioned above). NEBOSH will be alerted to this and will treat it as plagiarism.

**Good luck with the practical assessment!**

### Suggested Answers to Study Questions



#### No Peeking!

Once you have worked your way through the Study Questions in this book, use the Suggested Answers on the following pages to find out what you got right (and where you went wrong) to improve your understanding.

## Element 5: Physical and Psychological Health

### Question 1

This refers to a daily personal exposure to noise at a level of 85 dB(A) over the course of a working day (eight hours), or an equivalent exposure over a longer or shorter period. This represents the upper exposure action value at and above which action must be taken to reduce employee exposure. 'dB' refers to decibel – the sound pressure level. 'A' refers to the A-weighting matrix, which takes into account the sensitivity of the human ear to noise at different frequencies.

### Question 2

One limitation of ear defenders is that the seal between the ear and the protective device may be less than perfect due to long hair, spectacle frames and jewellery, incorrect fitting or the wearing of helmets or face shields. Other limitations are that they may become uncomfortable during use and be removed. They also need a dedicated storage facility.

Limitations of ear plugs are that they offer less noise reduction at high-noise levels, they are more difficult to see and therefore enforce, and they can be a source of contamination into the ear if hygiene practices are poor.

### Question 3

Symptoms of hand-arm vibration syndrome include:

- Tingling and numbness in the fingers and hands.
- Blanching (whitening) of the fingers on exposure to cold conditions.
- Reddening and pain of the fingers due to blood supply returning after a blanching attack.
- Loss of finger dexterity.
- Loss of grip strength.

### Question 4

The types of non-ionising radiation given off are:

- (a) Radiofrequency.
- (b) Infrared.
- (c) Ultraviolet, visible and infrared.
- (d) Visible.

### Question 5

Visible radiation is particularly dangerous to the eyes if it is intense (e.g. from a laser). Temporary or permanent blindness can be caused by intense visible light. If very intense, it can cause burns to exposed skin tissue.

## Question 6

The six work-related causes of stress, and an example of a preventive measure for each, are:

- Demands – ensuring that there are sufficient resources available to do the work required and that priorities and deadlines are negotiated and reasonable.
- Control – encouraging workers to plan their work, and make decisions about how it is completed and how problems will be tackled.
- Support – providing positive feedback, and focusing on performance, not on personality.
- Relationships – applying clear standards of conduct and policies to tackle harassment and bullying.
- Role – having clear work objectives, job descriptions and reporting responsibilities.
- Change – ensuring consultation and involvement of staff in determining processes.

## Question 7

Occupations at risk of violence at work are:

- Hospital accident and emergency staff.
- Police.
- Social workers.
- Bus and taxi drivers.
- Fire-fighters and paramedics.
- Traffic wardens.
- Railway staff.
- Teachers.

## Question 8

The strategy will depend on the nature of the work and, in particular, whether workers are located in a fixed building or out in the community:

- General strategy – clear policy, zero tolerance, training for all staff at risk (handling aggression and violence, diffusing situations, break away/self-defence).
- Fixed workplace – security guards, security doors, CCTV, screens, panic buttons.
- Out in the community – customer-vetting, visit-logging, safe system of work, remote supervision, communications.

## Question 9

Signs might include: lateness, increased absenteeism, poor quality of work, reduced work rate, theft, dishonesty, irritability and mood swings, poor working relationships and changes to personal appearance.

## Element 6: Musculoskeletal Health

### Question 1

A simple phrase outlining the aim of ergonomics is 'the aim of ergonomics is adapting the workplace environment, including tools and equipment, to suit the worker'.

### Question 2

The health risks arising from DSE workstation use are: physical stress, resulting in musculoskeletal injuries (such as back pain) and work-related upper limb disorders; eye strain; plus general fatigue and psychological stress.

### Question 3

The risk factors involved in a repetitive task include the rate of repetition, use of force, body posture, forces involved, duration, twisting, rest and recovery time, the equipment design and its adaptability, and environmental factors such as temperature and lighting.

### Question 4

The key requirements are:

- (a) The work surface or desk should be large enough to hold all necessary equipment and other items used from time to time, and to allow them to be arranged to suit the individual's needs. If necessary, it should also be deep enough to accommodate DSE for viewing at a comfortable distance without cramping the work surface in front of it.
- (b) The keyboard should be of appropriate design to be used in comfort, with keys of sufficient size and clarity to suit the demands of the task. It should be able to be tilted and separated from the screen so that the user can find a comfortable position.
- (c) The work chair must have an adjustable seat back, good lumbar support and be adjustable in height to suit the user. DSE chairs usually have a five-point base for good stability with wheels to allow the chair to be moved close to the desk.
- (d) There should be sufficient clear and unobstructed space at each workstation to enable the work to be done safely, allowing for the manoeuvring and positioning of materials. This should also provide for adequate freedom of movement.

### Question 5

The main injuries associated with manual handling are:

- Back injuries, such as a prolapsed disc.
- Work-related upper limb disorders.
- Muscle tears/strains.
- Tendon and ligament injuries/tears/strains.
- Hernias.
- Cuts, burns, dislocation and broken bones.

(Note that 'musculoskeletal disorders' is rather too general an answer and covers most of the specific injuries listed above.)



## Question 6

WRULD stands for 'work-related upper limb disorder' and refers to a range of recognised ill-health conditions affecting the upper limbs, particularly the soft connecting tissues (such as the muscles, tendons and ligaments) and the nerves of the hand, wrist, arm and shoulder.

WRULDs can arise from the repetition of ordinary movements (such as gripping, twisting, reaching or moving), often in a forceful and awkward manner, without sufficient rest or recovery time.

## Question 7

The risk factors associated with a load during handling are:

- Its weight, size, shape, rigidity or lack of it.
- The position and stability of its centre of gravity.
- The presence or absence of handles.
- Its surface texture.
- The stability of any contents and the contents themselves.

## Question 8

The main risk factors presented by the working environment are:

- Space restrictions on movement and posture.
- Conditions of floors and other surfaces.
- Variations in levels.
- Temperature and humidity.
- Strong air movements.
- Lighting conditions.

## Question 9

The risks of manual handling can be best minimised through the elimination of the handling activity, either by automation, or by the use of mechanical load handling equipment.

## Question 10

The vulnerable types of individuals who might be more prone to manual handling injury include:

- Pregnant women.
- People with pre-existing musculoskeletal disorders and injuries (such as prolapsed disc back injury).

## Question 11

(a) The most common risk from forklift trucks is that they may become unbalanced resulting in them shedding their load or tipping over. This is because of their small wheels and occurs particularly when they are loaded with the forks raised. Other risks include impact with pedestrians, fixed structures and other moving vehicles; and from the fuel, such as the explosion from charging lead-acid batteries.

(b) The main risks of sack trucks are overloading, instability of the load, tipping when moving over uneven ground or on slopes, and careless stowage causing trips or obstructing pedestrian thoroughfares and emergency escape routes.

- (c) The main risks associated with lifts and hoists are falls from a height (from a landing level, from the platform or with the platform) and being hit by materials falling from the platform. Other risks include being struck by the platform or other moving parts, and being struck by external objects or structures while riding on the platform.
- (d) The main risks associated with cranes are that they become unbalanced and topple over, the boom (jib or arm) of the crane may swing out of control, and the load may strike people or structures while being moved horizontally or falling in an uncontrolled descent.

### Question 12

- (a) The appropriate PPE for working with pallet trucks is safety footwear with toe-cap protection and good grip, and perhaps gloves for hand protection while handling loads.
- (b) The appropriate PPE for working with cranes is safety footwear with toe-cap protection and good grip, a hard hat, gloves and high-visibility clothing. Safety eyewear might also be specified in the risk assessment.

### Question 13

The typical safety precautions for safe use of a mobile crane are:

- Assessment of the ground conditions before siting the crane.
- Using the outriggers.
- Ensuring that the operator is qualified and competent.
- Ensuring that the crane has been maintained and has an in-date report of thorough examination.
- Using a banksman (signaller) to direct the lifting operation.
- Ensuring that the load is within the lifting capabilities of the crane.
- Making use of any warning devices or indicators fitted to the crane, such as the radius gauge and overload alarm.
- Not using the crane in adverse weather, particularly in high winds.
- Never lifting over a person.



## Element 7: Chemical and Biological Agents

### Question 1

The physical forms of chemicals that may exist in the workplace are solids, liquids, gases, vapours, mists, fumes, dusts and fibres.

### Question 2

Any five health hazard classifications of chemicals from: acute toxicity, skin corrosion/irritation, serious eye damage/eye irritation, respiratory or skin sensitisation, germ cell mutagenicity, carcinogenicity, reproductive toxicity, specific target organ toxicity (single and repeat exposure) and aspiration hazard.

### Question 3

Acute means that the substance has short-term effects (usually occurring after a large overexposure over a short duration of time).

Chronic means that the substance has long-term health effects (usually occurring after repeated low-level exposures over a long duration of time).

### Question 4

The routes of entry of chemical and biological agents into the body are: inhalation (into the lungs), ingestion (into the digestive system), absorption (through the skin) and injection (through the skin by physical puncture or at sites of damage) plus aspiration (drawing a liquid into the lungs).

### Question 5

The label on a substance which is dangerous for supply generally gives the following information:

- The name of the substance/mixture.
- The name(s) of the hazardous constituents.
- The indication(s) of danger and the corresponding symbols/warning phrases.
- Some basic precautions to take.
- Name, address and telephone number of the supplier.

### Question 6

Safety data sheets are intended to provide end-users with sufficient information about the hazards of the substance or mixture so that they can take appropriate steps to ensure health and safety in the workplace in relation to all aspects of their use, including their transport and disposal. They provide much more in-depth information than that found on labels.



### Question 7

Workplace exposure limits are maximum concentrations of airborne contaminants, measured across a reference period of time, to which workers may be exposed by inhalation.

Two reference periods are used:

- Short-Term Exposure Limits (STELs) over a 15-minute time period.
- Long-Term Exposure Limits (LTELs) over an eight-hour time period.

### Question 8

The limitations of WELs are that (any two from the following):

- They are designed only to control absorption into the body following inhalation.
- They take no account of human sensitivity or susceptibility (especially in relation to allergic response).
- They do not take account of the synergistic effects of mixtures of substances.
- They may be invalidated by changes in temperature, humidity or pressure.
- Some limits do not consider all possible health effects of a substance.

### Question 9

- (a) Substitution.
- (b) Work process change.
- (c) Reduced-time exposure.
- (d) Elimination.

### Question 10

Local exhaust ventilation is a control measure for dealing with contaminants generated from a point source. Dilution ventilation deals with contamination in the general atmosphere of a workplace area.

### Question 11

Dead areas are areas in the workplace where air remains relatively motionless and so is not diluted or mixed with air entering the space. They are a problem because high concentrations of undiluted hazardous gas or vapour can persist in these dead areas.

### Question 12

The main types of respirator are filtering facepiece respirators, half-mask respirators, full-face respirators and powered respirators. For breathing apparatus, the two main types are compressed airlines and self-contained systems.

### Question 13

The key criteria in the selection of the appropriate respirator to use are the type of hazard (dust, gas, vapour, etc.) and the category of danger, contaminant concentration levels and wearer acceptability.



### Question 14

The main purpose of routine health surveillance is to identify, at as early a stage as possible, any variations in the health of workers which may be related to working conditions. By doing this, the individual concerned can be further protected, if possible, and investigations can take place to determine if a wider problem exists.

### Question 15

Carbon monoxide (CO) is an asphyxiant gas. When inhaled, it reduces the oxygen available to the body. This happens because the CO combines with haemoglobin in red blood cells. This prevents oxygen transport by the blood. Symptoms include headache, drowsiness, unconsciousness and death at relatively low concentrations. This will happen even when oxygen concentrations are completely normal.

### Question 16

Three diseases associated with asbestos exposure include any from:

- Asbestosis – asbestos fibres lodge deep in the lungs and cause scar tissue formation. If enough of the lung is scarred, then severe breathing difficulties occur. It can prove fatal and increases the risk of cancer.
- Lung cancer – asbestos fibres in the lung trigger the development of cancerous growths in the lung tissue. It is usually fatal.
- Mesothelioma – asbestos fibres in the lung migrate through the lung tissue and into the cavities around the lung triggering the development of cancerous growths in the lining tissue. It is always fatal.
- Diffuse pleural thickening – thickening of the lining tissue of the lung causes breathing difficulties. It is not fatal.

### Question 17

The harmful effects of cement on health include:

- Irritation or corrosive burns to the eyes.
- Irritation of the respiratory tract.
- Irritant dermatitis on skin contact.
- Allergic dermatitis on repeated skin contact.
- Corrosive burns to the skin on prolonged contact.

## Element 8: General Workplace Issues

### Question 1

The six main welfare requirements in any workplace are: suitable and sufficient sanitary conveniences, washing facilities, changing rooms, accommodation for clothing, resting and eating facilities, and access to drinking water.

### Question 2

The protective measures to be used for working in conditions of extreme heat include:

- Providing good workplace ventilation such as air conditioning or fans to circulate air which has a cooling effect.
- Insulating heat sources by lagging hot pipes.
- Shielding heat sources to control radiant heat and prevent contact burns.
- Providing cool refuges where workers can escape the heat.
- Providing easy access to drinking water.
- Providing frequent breaks and job rotation.
- Providing appropriate clothing that allows the worker to sweat freely.

### Question 3

The safe method of working on a fragile roof includes the use of roof ladders (or crawling boards) laid across the roof surface, supported by the underlying load-bearing roof members, in order to distribute the load of the worker over a wide area.

### Question 4

The main risks of using ladders are:

- Workers falling from the ladder.
- The ladder tipping or toppling sideways.
- The ladder slipping away from the wall that it is propped against.
- Falling objects.
- Contact with live electrical services.

### Question 5

To prevent materials from falling from height in the first place, the following control measures should be used:

- Not stacking materials near edges and particularly unprotected edges.
- Close boarding of working platforms – minimising gaps between scaffold boards or placing sheeting over the boards so that material cannot fall through.
- Avoiding carrying materials up or down ladders, etc. by using hoists and chutes to move materials.
- Using leashes or lanyards attached to tools.

## Question 6

- (a) Standards are the vertical tubes (the uprights), ledgers are the long horizontal tubes running parallel to the face of the building and transoms are the short tubes spanning across ledgers perpendicular (at right angles) to the face of the building.
- (b) Tying secures the scaffolding to the building or structure, whereas bracing is used to stiffen the framework by joining the framework diagonally.

## Question 7

Precautions for the use of MEWPs include:

- Firm, level ground for the vehicle to stand on.
- Sufficient clearance from any building or obstacle.
- Avoidance of live overhead cables.
- Barriers in place to provide an exclusion zone, which also prevents collisions with the equipment.
- Adequate edge protection for the cradle.
- Use of a full-body safety harness and lanyard when in the cradle if necessary.
- Vehicle not to be moved with the cradle raised unless it is designed for that purpose.
- No overloading.
- Use must be restricted to trained, authorised staff (e.g. IPAF-certificated).

## Question 8

The angle at which ladders should be positioned is  $75^\circ$  to the horizontal (1 'out' to 4 'up' ratio).

## Question 9

Scaffolding should be formally inspected before being used for the first time, after any substantial alteration or any event likely to affect its strength or stability, and at regular intervals (usually weekly).

## Question 10

A confined space is any place, including any chamber, tank, vat, silo, pit, trench, pipe, sewer, flue, well or other similar space in which, by virtue of its enclosed nature, there arises a reasonably foreseeable risk of fire or explosion; loss of consciousness or asphyxiation arising from gas, fumes, vapour or lack of oxygen; drowning; asphyxiation as a result of entrapment in free-flowing solid; or loss of consciousness as a result of increased body temperature.

## Question 11

The issues that must be addressed by the safe system of work for entry into a confined space include:

- Level of supervision.
- Competency requirements of the people doing the work.
- Communication methods to be used inside the confined space.
- Atmospheric testing and monitoring before and during entry.
- Ventilation that may be required before and during entry.
- Removal of residues.

- Isolation and lock-off of in-feeds and out-feeds.
- Isolation and lock-off of electrical and mechanical hazards.
- PPE requirements for workers inside the confined space which may include respiratory protective equipment.
- Safe and quick access and egress methods.
- Fire prevention measures.
- Lighting that is suitable and safe to use in the atmosphere inside the confined space.
- Suitability of individuals in terms of body size and psychology (e.g. not claustrophobic).
- Emergency and rescue arrangements to cope with foreseeable emergencies.

## Question 12

Lone workers can be defined as workers who are separated from their work colleagues.

## Question 13

Control measures that might be used to reduce the risk associated with lone working activity includes any four from:

- No lone working for certain high-risk activities (such as confined space entry).
- Arrangements for remote supervision.
- Procedures for logging workers' locations when lone working.
- The use of mobile phones or radios to ensure good communication.
- Lone worker alarm systems to raise the alarm and pin-point the worker.
- Procedures to be adopted by workers when lone working.
- Emergency procedures to deal with the foreseeable incidents that might arise such as loss of contact with the worker, injury or ill health.
- Training for workers in those procedures.

## Question 14

The main hazards causing slips, trips and falls on the same level are wet, glossy or slippery floors; uneven or loose surfaces; and obstacles on the surface.

## Question 15

Eight control measures that may be used to reduce the risk of slipping and tripping in the workplace are any from: adequate lighting, use of appropriate footwear with good grip, level floor surfaces, non-slip floor surfaces, good drainage, spill control, use of designated walkways, provision of handrails to steps and stairs, and maintenance and repair of defects.

## Question 16

The main types of risk associated with vehicle operations are loss of control, overturning and collisions with other vehicles, pedestrians or fixed objects.



## Question 17

Several unsafe practices that may cause a forklift truck to overturn may be involved, including:

- Driving too fast.
- Traversing across a slope.
- Driving with the load raised up.
- Sudden heavy braking.
- Uneven tyre pressures.
- Cornering too fast.
- Driving into potholes or over kerbs.

## Question 18

Management of vehicle operations and movements includes the following safety measures:

- Restricting vehicle use to qualified, authorised staff only.
- Safe systems of work.
- Speed limits.
- Designated vehicle parking places.
- Signs and markings.
- Signalling and use of banksmen.
- Loading and unloading procedures.
- General rules to make sure vehicles do not become hazards.

## Question 19

The equipment that might be fitted to vehicles to protect drivers are seat belts, protective roll bar or roll cage (ROPS) and guards to protect the driver in the event of falling objects (FOPSs).

## Question 20

Warning lights and alarms are used to alert pedestrians and other drivers of the approach of a vehicle. They are particularly important at blind corners, junctions and doorways, and when reversing.

## Question 21

There are various methods of separation of vehicles and pedestrians:

- Vehicle-free and pedestrian-free areas/zones.
- Barriers to separate routes for pedestrians and vehicles.
- Clear surface markings to demark vehicle and pedestrian routes.
- Kerbed pavements for outdoor roadways.
- Designated crossing points for pedestrians to use when crossing vehicle routes.
- Separate doorways and access points for pedestrians.



### Question 22

The first option to consider when controlling driving risk is the elimination of the need to travel, for example by the use of a video conference call rather than a face-to-face meeting.

### Question 23

The three main areas of concern that can be managed by the risk assessment process are the driver of the vehicle, the vehicle and the journey to be made.

### Question 24

Three factors associated with the journey can be chosen from: the route to be taken, the schedule for the journey, the time allowed for the journey, the distance to be travelled and any adverse weather conditions.



## Element 9: Work Equipment

### Question 1

Maintenance workers are sometimes at greater risk than operators when working on machinery because:

- Guards have to be removed.
- Safety devices have to be disabled.
- Power sources may be exposed.
- Stored power may be released.
- Access may be difficult.
- Manual handling may be difficult.
- New hazards may be introduced.
- They may be under pressure to complete the job quickly.

### Question 2

- (a) Three likely causes of accidents involving the use of simple hand tools arise from operator error, misuse and improper maintenance.
- (b) The additional risks of portable power tools arise from the speed and force of the tool itself; the hazards associated with the power source such as electricity, petrol or diesel; and the additional hazards that the tool creates such as noise, vibration and exhaust fumes.

### Question 3

Power tools are marked to identify them for inspection purposes as part of a routine maintenance system (e.g. if the tool is electrically operated, it should be given a periodic, thorough inspection and test).

### Question 4

The non-mechanical hazards arising from the use of machinery are noise; vibration; electricity; extreme temperatures; hazardous substances; radiation (both ionising and non-ionising); fire and explosion; slips, trips and falls; and ergonomics.

### Question 5

Drawing-in injuries occur where a part of the body is caught between two moving parts and drawn into the machine (e.g. drawn in between two counter-rotating rollers in a printing press).

### Question 6

The hierarchy of protective measures is as follows:

- Fixed, enclosed guards.
- Other types of guard such as interlocked guards.
- Protection devices.
- Protection appliances.
- The provision of information, instruction, training and supervision.



### Question 7

The principles of interlocked guards are that they will:

- stop the machine immediately when the guard is opened; or
- not allow the guard to be opened until the machine has fully stopped; and
- not allow the machine to restart until the guard has been properly closed.

### Question 8

A trip device stops the motion of a machine when a person enters the hazard area.

### Question 9

There are three potentially serious limitations of adjustable guards, which are that they:

- Do not completely prevent access to dangerous parts.
- Can easily be defeated or not used.
- Rely upon operators being entirely vigilant in providing their own safety.

### Question 10

A ‘protective appliance’ is a hand-held tool or device that is used to hold or manipulate a workpiece as it enters the machine, is worked on and/or removed from the machine. It allows the operator to keep control of the workpiece while not coming into contact with the hazardous parts of the machine. Protective appliances include push-sticks, jigs and other types of holders.

### Question 11

Operators are required to be trained in the use of safety equipment before using the tools or machinery.

### Question 12

Two-handed controls might be overridden by two people, each holding one handle/operating one button.

### Question 13

Requirements for any guarding system are that they should (any five from the following):

- Meet relevant standards.
- Be compatible with the process.
- Be of adequate strength.
- Not interfere with any need to see inside the machine.
- Not interfere with any ventilation required.
- Be properly maintained.
- Not be removed when the machine needs to be maintained.
- Not increase risk.
- Not be easily bypassed or disabled.



## Question 14

- (a) The hazards that arise from the use of the bench-top grinder are:
- Abrasion on contact with the rotating abrasive wheel.
  - Drawing in at the nip point between the wheel and the tool rest.
  - Puncture by ejection of parts of the wheel during normal use or if it bursts.
  - Entanglement with the spindle on which the wheel is mounted.
  - Electricity.
  - Hot parts caused by friction (especially the workpiece being ground).
  - Inhalation of dust.
  - Noise and vibration.
- (b) The hazards that arise from the use of the chainsaw are:
- Cutting on contact with the moving blade.
  - Entanglement with the moving blade.
  - Drawing in at the nip point between the blade and the casing.
  - Puncture by ejected parts (especially broken blade fragments).
  - Burns from the hot exhaust system.
  - Noise.
  - Vibration (into the hands).
  - Fire and explosion from petrol (fuel).
  - Ergonomic from handling.
  - Inhalation of dust, fumes and lubricating oils.
- (c) The hazards that arise from the use of the bench-mounted saw are:
- Cutting on contact with the blade.
  - Ejection of the workpiece during cutting (referred to as 'kick back').
  - Entanglement with the drive motor spindle.
  - Drawing in at nip points between the motor and the drive belt.
  - Electricity.
  - Noise.
  - Inhalation of wood dust.

## Question 15

PPE that should be worn when using a chainsaw includes:

- Face visor/eye protection.
- Ear defenders.



## Suggested Answers to Study Questions

- Hard hat.
- Stout gloves.
- Boots with good grip and steel-toe caps.
- Cut-resistant trousers or chaps.
- Stout shirt.

## Element 10: Fire

### Question 1

- (a) Friction is the process whereby heat is given off by two materials moving against one another. In the absence of a lubricant or cooling substance, it can result in the surfaces of the materials becoming hot or actually producing sparks, either of which may be sufficient to cause ignition.
- (b) A space heater is designed to give off considerable heat and, close to the heater, temperatures may be very high. A fire may be started by combustible materials being placed too close to the source of the heat (through radiation) or by obstructing the air intake into the heater.

### Question 2

If the door is opened into a room where a fire appears to have gone out, it allows fresh air (containing oxygen) into the room which might result in the fire reigniting and burning with renewed intensity.

It is also not safe to do because the temperature in the room may be very high, the room will probably be full of smoke and may well contain an oxygen-depleted atmosphere – all of which can cause someone to collapse and die.

### Question 3

- (a) Class C – fires involving gases.
- (b) Class B – fires involving flammable liquids.
- (c) Class A – fires involving solid, mainly carbonaceous, materials (here, most likely paper and furniture, etc.). Possibly electrical fire if items such as desktop computers or printers are burning.

### Question 4

- (a) Convection.
- (b) Radiation.
- (c) Conduction.

### Question 5

Direct burning.

### Question 6

Fire risk can be minimised in a woodworking area by ensuring that wood shavings and dust are cleared regularly and ignition sources, such as cigarettes and sparks from electrical equipment, do not come into contact with combustible materials.

### Question 7

The volume of flammable liquids in use at any one time should be minimised and it should be held in appropriate (usually metal), correctly labelled containers with secure lids. The need to decant highly flammable liquids from one container to another should be minimised, reducing the risk of spillages.

### Question 8

The steel beam will distort – it will lengthen, lose strength and perhaps twist – possibly causing the collapse of any structure it is supporting. It will also conduct heat and increase the possibility of fire spread.

### Question 9

Typical characteristics of a fire door:

- Rated to withstand fire for a minimum period of time (e.g. 30 minutes).
- Fitted with a self-closing device.
- Fitted with an intumescent strip and/or cold smoke seal.
- Vision panel of fire-resistant glass.
- Clearly labelled 'Fire Door – Keep Shut'.

### Question 10

Manual systems alone can only raise an alarm over a limited area and for a limited time. There has to be some means for the person raising the alarm to make it general – by using the phone or public address system, or a manual/electric system.

### Question 11

The two main types of automatic fire detector are smoke detectors (both ionising and optical) and heat detectors (both fixed temperature and rate of rise).

### Question 12

The main points to be covered in training in the use of fire extinguishers includes:

- A general understanding of how extinguishers operate.
- The importance of using the correct extinguisher for different classes of fire.
- Practice in the use of different extinguishers.
- Knowing when to and when not to tackle a fire.
- Knowing when to leave a fire that has not been extinguished.

### Question 13

The three main ways of extinguishing a fire are: starvation (removing the fuel), smothering (removing the oxygen) and cooling (removing the heat).

### Question 14

- (a) Water – Class A.
- (b) Carbon dioxide – Class B and electrical fires.
- (c) Dry powder – suitable for Classes A, B, C, D and electrical fires (but messy!).
- (d) Foam – Class A and B.
- (e) Fire blankets – small Class A fires and high-temperature fat fires (Class F).

### Question 15

The purpose of signs used on escape routes is to direct occupants to the means by which they can safely leave the premises.



## Question 16

The escape route should be as straight as possible direct to the assembly point, clear of obstruction, free of materials that could pose a fire hazard, and be wide enough throughout (including at doorways and openings) to provide for the unrestricted flow of people.

## Question 17

An assembly point should be a place of total safety (outside the building, in the open air, away from any further danger from the fire). A refuge or a place of relative safety is a fire-protected area, that is not outside in the open air, where people can wait for a short time.

## Question 18

The possible responsibilities of fire marshals during a fire evacuation might include:

- Ensuring all occupants leave by the designated escape route.
- Searching all areas to ensure that the area is clear.
- Ensuring that fire escape routes are kept open and clear at all times.
- Ensuring all doors and windows are closed on leaving the area.
- Assisting people from the building.
- Conducting the roll call at the assembly area.
- Meeting the fire service on arrival and informing them of all relevant details.

## Question 19

There might be a roll call to ensure that all people in the affected area are present.

## Element 11: Electricity

### Question 1

An electric shock can result in muscle tremor and contractions (often violent). The muscle contractions can cause the inability to let go, and may cause the respiratory system to fail as the casualty cannot breathe. It can result in the heart beating spasmodically (ventricular fibrillation) or cardiac arrest. It can also result in burns to the skin at the point of entry and exit and deep tissue burns where the current has flowed. The severity of injury will depend on many factors such as current flow, duration of contact and pathway through the body.

### Question 2

Arcing is the passage of electrical current through air from one conductor to another or to earth. If the arc is connected to a person, the victim may be subject to burns and electric shock from the current which passes through the body. There is a danger of burns from ultraviolet radiation and radiated heat, even where the arc does not actually touch a person, and of molten metal burns if the current flow is sufficient to melt metal conductors. Arcing can also provide a source of ignition for fire.

### Question 3

Earthing provides a safe path for any fault current to be dispersed to earth through a low-resistance conductor.

### Question 4

A fuse forms a weak link in a circuit by overheating and melting by design if the current exceeds the safe limit. If a fuse blows then it must be replaced. A circuit breaker is an electromechanical device in the form of a switch that automatically opens if the circuit is overloaded by excess current. When a circuit breaker trips out it can be reset and does not have to be replaced.

### Question 5

Switching off refers to depriving the equipment of electric power, but still leaving it connected. Isolation refers to physically separating it from any source of electric power, with the additional step being taken of ensuring that it cannot be inadvertently re-energised.

### Question 6

Reduced low-voltage circuits lower the effect of any shock received from making contact with part of the circuit because of the relationship between voltage and current. If resistance stays the same, then less voltage means less shock current.

### Question 7

If mains-supplied electric hand tools are used outside, then a Residual Current Device (RCD) should be used. A RCD is specifically designed to trip out in response to current leakage as might happen in the event of an electric shock accident. RCDs are sensitive and fast acting and are good at preventing fatal electric shock.



## Question 8

The user should visually check for signs that the equipment is in good condition. They should look for:

- Damage to the cable sheaths, joints or plugs.
- Evidence that the equipment has been subjected to conditions for which it is not suitable (e.g. it is wet or excessively contaminated).
- Damage to the external casing of the equipment or loose parts or screws.

## Question 9

The first action should be to break any contact between the casualty and the live conductor that they might be in contact with and so still receiving a shock from.

However, before this can be done, the area must be assessed to ensure that it is safe to approach the casualty and the location they are in.

