Non-destructive testing of steel tubes —
Part 9:
Automated ultrasonic testing for
the detection of laminar imperfections
in strip/plate used for the manufacture
of welded steel tubes

Essais non destructifs des tubes en acier —

*Partie 9: Contrôle automatisé par ultrasons pour la détection
des dédoubleures dans les bandes/tôles fortes utilisées
pour la fabrication des tubes en acier soudés*



Reference number
ISO 10893-9:2011(E)

© ISO 2011

PDF disclaimer

This PDF file may contain embedded typefaces. In accordance with Adobe's licensing policy, this file may be printed or viewed but shall not be edited unless the typefaces which are embedded are licensed to and installed on the computer performing the editing. In downloading this file, parties accept therein the responsibility of not infringing Adobe's licensing policy. The ISO Central Secretariat accepts no liability in this area.

Adobe is a trademark of Adobe Systems Incorporated.

Details of the software products used to create this PDF file can be found in the General Info relative to the file; the PDF-creation parameters were optimized for printing. Every care has been taken to ensure that the file is suitable for use by ISO member bodies. In the unlikely event that a problem relating to it is found, please inform the Central Secretariat at the address given below.



COPYRIGHT PROTECTED DOCUMENT

© ISO 2011

All rights reserved. Unless otherwise specified, no part of this publication may be reproduced or utilized in any form or by any means, electronic or mechanical, including photocopying and microfilm, without permission in writing from either ISO at the address below or ISO's member body in the country of the requester.

ISO copyright office
Case postale 56 • CH-1211 Geneva 20
Tel. + 41 22 749 01 11
Fax + 41 22 749 09 47
E-mail copyright@iso.org
Web www.iso.org

Published in Switzerland

Contents

Page

Foreword	iv
1 Scope	1
2 Normative references	1
3 Terms and definitions	1
4 General requirements	2
5 Test method	2
6 Reference sample	4
6.1 General	4
6.2 Dimensions of reference standards	4
6.3 Verification of reference standards	4
7 Equipment calibration and checking	5
8 Acceptance	6
9 Test report	7
Annex A (normative) Procedure for the determination of the size of laminar imperfections by manual ultrasonic testing	8

Foreword

ISO (the International Organization for Standardization) is a worldwide federation of national standards bodies (ISO member bodies). The work of preparing International Standards is normally carried out through ISO technical committees. Each member body interested in a subject for which a technical committee has been established has the right to be represented on that committee. International organizations, governmental and non-governmental, in liaison with ISO, also take part in the work. ISO collaborates closely with the International Electrotechnical Commission (IEC) on all matters of electrotechnical standardization.

International Standards are drafted in accordance with the rules given in the ISO/IEC Directives, Part 2.

The main task of technical committees is to prepare International Standards. Draft International Standards adopted by the technical committees are circulated to the member bodies for voting. Publication as an International Standard requires approval by at least 75 % of the member bodies casting a vote.

Attention is drawn to the possibility that some of the elements of this document may be the subject of patent rights. ISO shall not be held responsible for identifying any or all such patent rights.

ISO 10893-9 was prepared by Technical Committee ISO/TC 17, *Steel*, Subcommittee SC 19, *Technical delivery conditions for steel tubes for pressure purposes*.

This first edition cancels and replaces ISO 12094:1994, which has been technically revised.

ISO 10893 consists of the following parts, under the general title *Non-destructive testing of steel tubes*:

- *Part 1: Automated electromagnetic testing of seamless and welded (except submerged arc-welded) steel tubes for the verification of leaktightness*
- *Part 2: Automated eddy current testing of seamless and welded (except submerged arc-welded) steel tubes for the detection of imperfections*
- *Part 3: Automated full peripheral flux leakage testing of seamless and welded (except submerged arc-welded) ferromagnetic steel tubes for the detection of longitudinal and/or transverse imperfections*
- *Part 4: Liquid penetrant inspection of seamless and welded steel tubes for the detection of surface imperfections*
- *Part 5: Magnetic particle inspection of seamless and welded ferromagnetic steel tubes for the detection of surface imperfections*
- *Part 6: Radiographic testing of the weld seam of welded steel tubes for the detection of imperfections*
- *Part 7: Digital radiographic testing of the weld seam of welded steel tubes for the detection of imperfections*
- *Part 8: Automated ultrasonic testing of seamless and welded steel tubes for the detection of laminar imperfections*
- *Part 9: Automated ultrasonic testing for the detection of laminar imperfections in strip/plate used for the manufacture of welded steel tubes*
- *Part 10: Automated full peripheral ultrasonic testing of seamless and welded (except submerged arc-welded) steel tubes for the detection of longitudinal and/or transverse imperfections*

- *Part 11: Automated ultrasonic testing of the weld seam of welded steel tubes for the detection of longitudinal and/or transverse imperfections*
- *Part 12: Automated full peripheral ultrasonic thickness testing of seamless and welded (except submerged arc-welded) steel tubes*

© ISO 2011. All rights reserved.

Non-destructive testing of steel tubes —

Part 9:

Automated ultrasonic testing for the detection of laminar imperfections in strip/plate used for the manufacture of welded steel tubes

1 Scope

This part of ISO 10893 specifies requirements for the automated ultrasonic testing of strip/plate used in the manufacture of welded tubes for the detection of laminar imperfections carried out in the pipe mill before or during pipe production.

NOTE 1 For welded tubes, an alternative ultrasonic testing specification for the detection of laminar imperfections is available, which can be applied, at the discretion of the manufacturer, by ultrasonic testing of the tubes subsequent to seam welding according to ISO 10893-8.

NOTE 2 By agreement between the purchaser and manufacturer, the requirements of this part of ISO 10893 can be applied on strips/plates of SAW tubes in the pipe form after seam welding.

This part of ISO 10893 can also be applicable to the testing of strips/plates used in the manufacture of circular hollow sections.

2 Normative references

The following referenced documents are indispensable for the application of this document. For dated references, only the edition cited applies. For undated references, the latest edition of the referenced document (including any amendments) applies.

ISO 5577, *Non-destructive testing — Ultrasonic inspection — Vocabulary*

ISO 9712, *Non-destructive testing — Qualification and certification of personnel*

ISO 11484, *Steel products — Employer's qualification system for non-destructive testing (NDT) personnel*

3 Terms and definitions

For the purposes of this document, the terms and definitions given in ISO 5577 and ISO 11484 and the following apply.

3.1

reference standard

standard for the calibration of non-destructive testing equipment (e.g. drill holes, notches, recesses)

3.2

reference sample

sample (e.g. segment of plate/strip) containing the reference standard(s)

3.3

tube

hollow long product open at both ends, of any cross-sectional shape

3.4
seamless tube
tube made by piercing a solid product to obtain a tube hollow, which is further processed, either hot or cold, into its final dimensions

3.5
welded tube
tube made by forming a hollow profile from a flat product and welding adjacent edges together, and which after welding can be further processed, either hot or cold, into its final dimensions

3.6
manufacturer
organization that manufactures products in accordance with the relevant standard(s) and declares the compliance of the delivered products with all applicable provisions of the relevant standard(s)

3.7
agreement
contractual arrangement between the manufacturer and purchaser at the time of enquiry and order

3.8
laminar imperfection
imperfection located in the wall thickness and generally parallel to the pipe surfaces

NOTE Its extension can be calculated by measuring its outlined area on the external surface.

4 General requirements

- 4.1** An ultrasonic test of the strip/plate shall be carried out before or during pipe production in the flat form.
- 4.2** The strip/plate under test shall be sufficiently free of surface irregularities and foreign matter as to ensure the validity of the test.
- 4.3** This test shall be carried out by suitable trained operators qualified in accordance with ISO 9712, ISO 11484, or equivalent and supervised by competent personnel nominated by the manufacturer. In the case of third-party inspection, this shall be agreed on by the purchaser and manufacturer.

The operating authorization issued by the employer shall be according to a written procedure. Non-destructive testing (NDT) operations shall be authorized by a level 3 NDT individual approved by the employer.

NOTE The definition of levels 1, 2 and 3 can be found in appropriate International Standards, e.g. ISO 9712 and ISO 11484.

5 Test method

- 5.1** The strip/plate shall be tested using an ultrasonic pulse echo technique for the detection of laminar imperfections, with ultrasound transmitted in the direction normal to the strip/plate surface or using the ultrasonic through-transmission technique at the discretion of the manufacturer.
- 5.2** During testing, the strip/plate and the probe assembly shall be moved relative to each other such that the strip/plate surface is scanned along equidistant scan lines parallel or transverse to the principal rolling direction of the strip/plate, with a minimum coverage and a maximum allowable gap between adjacent scanning tracks, as given in Table 1. For the oscillating technique, the minimum coverage shall be half of the values given in Table 1. The relative speed of movement during testing shall not vary by more than $\pm 10\%$.

Table 1 — Acceptance levels and minimum coverage of the strip/plate and maximum gap between adjacent scanning tracks

Acceptance level	Minimum coverage	Maximum gap between adjacent scanning tracks
	%	mm
U1	20	100
U2	10	150
U3	5	200

5.3 The longitudinal strip/plate edges shall be 100 % ultrasonically tested for the detection of laminar imperfections over a width of at least 15 mm, plus, if appropriate, the total width of edge material which shall be removed from each original strip/plate prior to seam welding, in order to detect the relevant minimum imperfection length, L_{\min} , as given in Table 2.

For determining the extent of the laminated suspect area, adjacent suspect areas separated by less than the smaller of the two minor axes of the laminations shall be considered as one lamination.

NOTE The longitudinal edges are defined as those parallel to the principal rolling direction.

Table 2 — Acceptance levels and minimum detectable and maximum acceptable size of laminar imperfections at strip/plate edges

Acceptance level	Minimum individual size of laminar imperfections that shall be considered Length L_{\min} mm	Maximum acceptable size of laminar imperfections		
		Individual dimension		Maximum number of laminar imperfections ^a per metre of edge length, where $L_{\min} \leq L \leq L_{\max}$ and $E \leq E_{\max}$
		Length L_{\max} mm	Size (product of length and width) E_{\max} mm ²	
U1	10	20	250	3
U2	20	40	500	4
U3	30	60	1 000	5

^a Only laminar imperfections exceeding 6 mm in width (C_{\min}) shall be considered.

5.4 The suggested maximum width of each probe, or each active aperture when using phased array probes, should be 25 mm measured in any direction. However, manufacturers may use larger transducers providing their capability for detecting the adopted reference standard; on request, this capability shall be demonstrated.

In the case of dual transducer probes with different sizes of transducers within the transducer assembly, the dimension of the smallest transducer shall be used to calculate the coverage.

5.5 The equipment for automated testing shall be capable of classifying strip/plate as either acceptable or suspect by means of an automated trigger/alarm level combined with a marking and/or sorting system.

6 Reference sample

6.1 General

6.1.1 The reference standards defined in this part of ISO 10893 are convenient standards for calibration of non-destructive testing equipment. The dimensions of these standards should not be construed as the minimum size of imperfection detectable by such equipment.

6.1.2 The ultrasonic equipment shall be calibrated either electronically using any flat reference sample [see 7.1 a)] or a flat reference sample comprising flat-bottomed circular, square or rectangular recess (see Figure 1) machined into the surface of the reference sample [see 7.1 b)].

The flat-bottomed circular reference standard shall be used as the primary means of establishing the test sensitivity. When using one of the other types of reference standards, the test sensitivity shall be adjusted such that it is equivalent to that obtained when using the flat-bottomed circular recess.

For the through-transmission technique, either the recess shall be filled with a suitable sound attenuating material, or a suitable sound attenuating material of the same dimensions as the reference standard shall be attached to the surface of the test piece.

6.1.3 The reference recess shall be obtained by machining, spark erosion or other appropriate methods.

NOTE The bottom or the bottom corners of the recess can be rounded.

6.1.4 The reference sample shall have a similar surface finish and similar acoustic properties (e.g. sound velocity and attenuation coefficient) as the strip/plate under test. The reference sample selected by the manufacturer for calibration purposes shall be of convenient length and width.

6.2 Dimensions of reference standards

The dimensions of the recess reference standards (see Figure 1) shall be as follows:

- a) width, w : $6 \text{ mm} \begin{smallmatrix} +0,6 \\ 0 \end{smallmatrix} \text{ mm}$;
- b) depth, d : $T/4 < d < T/2$, with a maximum of 25 mm;
- c) length, l : $\geq 6 \text{ mm}$ with a maximum of 25 mm.

6.3 Verification of reference standards

The reference standard dimensions and shape shall be verified by a suitable technique.

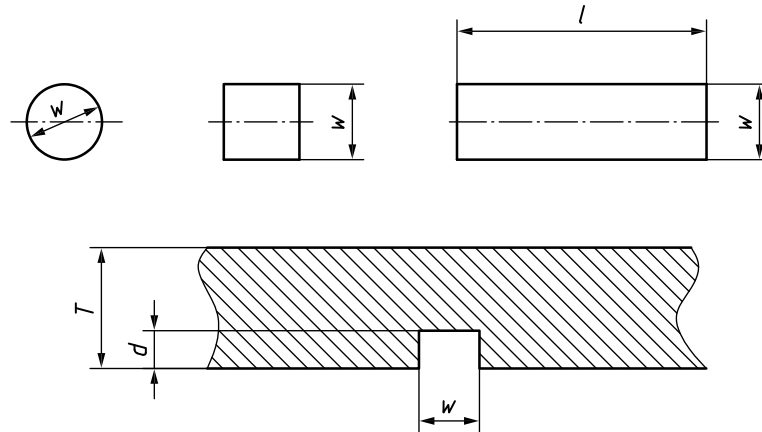
**Key**

- d depth of recess
- l length of recess
- T specified wall thickness
- w width or diameter of recess

Figure 1 — Reference standard recess forms

7 Equipment calibration and checking

7.1 At the start of each test cycle, the equipment shall be calibrated statically either without reference standard in accordance with 7.1 a) or using a reference standard in accordance with 7.1 b).

- a) Calibration without reference standard: with the probe assembly positioned on the strip/plate under test, the full amplitude of the first back-wall echo minus 6 dB shall be used to activate the respective trigger/alarm of the equipment.

The test sensitivity may also be established with DAC (distance amplitude correction) curves as supplied by the transducer manufacturer or with DAC curves as prepared by the tube or strip/plate manufacturer using, in both cases, the 6 mm flat-bottomed hole curve.

The manufacturer shall demonstrate that, at the set sensitivity, the equipment will detect, under static conditions, the reference recess as given in 6.1 2 and Figure 1. If this is not the case, the necessary adjustment in sensitivity shall be made prior to the production test run.

- b) Calibration using a reference standard: under static conditions, with the transducer or each transducer in turn centrally located over the reference standard, the full signal amplitude of the signal obtained from the reference standard shall be used to activate their respective trigger/alarm of the equipment.

7.2 During production testing of the strip/plate, the relative translational speeds and pulse repetition frequency shall be chosen such that the minimum coverage values and maximum separation values between adjacent scanning tracks given in Table 1 are obtained.

7.3 The calibration of the equipment shall be checked at regular intervals during the production testing of strip/plate.

The frequency of checking the calibration shall be at least every 4 h, but also whenever there is an equipment operation team changeover and at the start and end of the production run.

7.4 The equipment shall be recalibrated if any of the parameters which were used during the initial calibration are changed.

7.5 If, on checking during production testing, the calibration requirements are not satisfied, even after increasing the test sensitivity by up to 3 dB to allow for system drift, all strips/plates tested since the previous equipment check shall be retested after the equipment has been recalibrated.

8 Acceptance

8.1 Any strip/plate producing signals lower than the trigger/alarm level shall be deemed to have passed this test.

8.2 Any strip/plate producing signals equal to or greater than the trigger/alarm level shall be designated suspect or, at the discretion of the manufacturer, may be retested. If, after two consecutive retests, all signals are lower than the trigger/alarm level, the strip/plate shall be deemed to have passed this test; otherwise, the strip/plate shall be designated as suspect.

NOTE If applicable, the evaluation can be based on DAC curves.

8.3 For suspect strips/plates, one or more of the following actions shall be taken, subject to the requirements of the product standard:

- a) the suspect area shall be explored by a manual ultrasonic compression wave technique in accordance with Annex A to establish the extent of the laminar imperfections. The product shall be deemed to have passed this test if the size and frequency of the laminar imperfections do not exceed the values given in Tables 2 and 3. If the width, C , of the laminar imperfection exceeds the C_{min} that shall be considered (see also the note in Table 3), an area of 500 mm × 500 mm with the indication in the centre shall be explored 100 % to establish the presence of other laminar imperfections exceeding B_{max} and to determine if the population density of laminar imperfections $> B_{min}$ and $< B_{max}$ exceeds the permissible values in Table 3. In the event of further laminar imperfections exceeding the minimum width that shall be considered as being detected, the exploration shall be extended for a further area of 500 mm × 500 mm with the new indication at the centre. For the determination of the extent of the laminated suspect area, adjacent suspect areas separated by less than the smaller of the two minor axes of the laminations shall be considered as one lamination;
- b) the suspect area shall be cropped off;
- c) the strip/plate shall be deemed not to have passed the test.

Table 3 — Acceptance levels, minimum size that shall be detected and maximum acceptable size of laminar imperfections in the strip/plate body

Acceptance level	Minimum individual size of laminar imperfections that shall be considered		Maximum acceptable area of laminar imperfections		
	Individual area B_{min}^a mm ²	Minimum width C_{min} mm	Individual area B_{max}^a mm ²	Sum of individual areas $\geq B_{min}$ to $\leq B_{max}^a$ in percentage of strip/plate area	
				Per any metre of strip/plate length max.	Average per metre of strip/plate length max.
U1	$160 + w/4^b$	12	$160 + w^b$ with a maximum of 2 500 mm ²	1	0,5
U2	$160 + w/2^b$	15	$160 + 2 w^b$ with a maximum of 5 000 mm ²	2	1
U3	$160 + w^b$	20	$160 + 4 w^b$ with a maximum of 10 000 mm ²	4	2

^a B_{min} and B_{max} shall, when calculated as product of length and width of lamination, be rounded up to the next 10 mm².

^b w = strip/plate width, in millimetres.

9 Test report

When specified, the manufacturer shall submit to the purchaser a test report including at least the following information:

- a) reference to this part of ISO 10893, i.e. ISO 10893-9;
- b) statement of conformity;
- c) any deviation, by agreement or otherwise, from the procedures specified;
- d) product designation by steel grade and size;
- e) type and details of test technique(s);
- f) equipment calibration method used;
- g) description of the reference standard acceptance level;
- h) date of test;
- i) operator identification.

Annex A (normative)

Procedure for the determination of the size of laminar imperfections by manual ultrasonic testing

A.1 General

This annex covers the procedure for manual ultrasonic pulse echo scanning of strip/plate for the determination of the extent of laminated suspect areas found by automated/semi-automated testing for the detection of laminar imperfections.

In cases of arbitration between the manufacturer and the purchaser or his representative regarding the extent and frequency of detected laminar imperfections, this procedure shall be used. This procedure determines the details of the sizing method to establish the extent and frequency of laminar imperfections in steel strip/plate.

A.2 Surface condition

The surface of the strip/plate shall be sufficiently free of foreign matter as to ensure the validity of the test.

A.3 Test equipment requirements

A.3.1 The ultrasonic probe shall be guided over the strip/plate surface either manually or by mechanical means. The ultrasound shall be transmitted in the direction normal to the tube surface.

A.3.2 One of the following two types of ultrasonic testing equipment shall be used.

- a) Equipment with a screen display and gain control, adjustable in 2 dB steps. The gain control shall be adjusted such that the ultrasonic signals from the laminated suspect area under evaluation are between 20 % and 80 % of the usable height of the screen display.
- b) Equipment without a screen display where automated signal amplitude measurement/assessment facilities are used. The amplitude measuring unit shall be capable of signal amplitude assessment steps not exceeding 2 dB.

A.3.3 If dual transducer probes are used for manual determination of the size of the laminated suspect area, examples of details given in Table A.1 shall be noted.

Table A.1 — Examples of details for the use of dual transducer probes

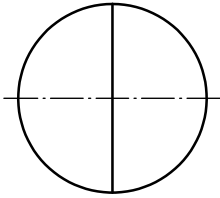
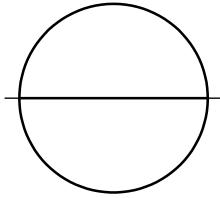
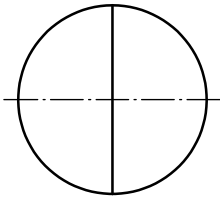
Probe-to-lamination distance	Type of dual transducer probe ^a	Plane of acoustic separation ^b
≤ 20 mm	Either — Nominal frequency: 4 MHz to 5 MHz — Roof angle: approximately 0° or 5° — Transducer size: 8 mm to 15 mm — Focal distance: 10 mm to 12 mm	At right angles to PRD 
	or — Nominal frequency: 4 MHz — Roof angle: approximately 0° or 5° — Transducer size: 18 mm to 20 mm — Focal distance: 10 mm to 15 mm	Parallel to PRD 
> 20 mm	— Nominal frequency: 4 MHz — Roof angle: approximately 0° or 5° — Transducer size: 15 mm to 25 mm — Focal distance: 20 mm to 60 mm	At right angles to PRD 

^a Probe with circular or rectangular transducers may be used.

^b PRD: principal rolling direction.

A.4 Test procedure

Laminar imperfections shall be located by comparing the amplitude of the imperfection echo with the amplitude of the echo of a 6 mm flat-bottom hole used during calibration.

Only those imperfections giving an echo at least equivalent in amplitude to that obtained with the 6 mm flat-bottom hole shall be considered.

In order to determine the extent of laminar imperfections that shall be considered, the method of measuring the half-amplitude value shall be used.

This method requires that the ultrasonic probe be passed over the laminated suspect area in transverse direction (determination of dimension C) and longitudinal direction (determination of dimension L). The suspect location shall be 100 % scanned. During the transverse scan, the positions C_1 and C_2 shall be determined where, over the greatest transverse extent, the magnitude of the intermediate reflection equals half of the related maximum value (6 dB difference in signal level). If this value is less than the minimum allowable width (see Table 3) that shall be considered, no further explorations shall be done. Similarly, during the longitudinal scan, the positions L_1 and L_2 shall be determined. The distances between points C_1 and C_2 and L_1 and L_2 are defined as the maximum width and length dimensions, respectively. The product of these dimensions is defined as the area of the equivalent laminar imperfection.

ICS 23.040.10; 77.040.20; 77.140.75

Price based on 9 pages