

UNIT NO. 1.10

REVISION ASSIGNMENT

We have now reached the mid point of our studies for the LEEA Part 1 Entry Examination; it is therefore time to take stock to see how well you remember the key points. Although Part 1 Entry Examination is not a qualification, it is an important step towards obtaining a qualification. Passing the examination demonstrates that you have a good overall understanding of the broad subject matter that will support you when going on to study for a specialised subject qualification. Indeed this is considered vital, so that only candidates who have passed the Part 1 entry examination are permitted to qualify in a specialised subject. This Assignment is therefore intended to enable you to monitor your progress so far and guide you to those matters you need to revise.

The Part 1 Entry Examination is in the form of a multi-choice test paper of 100 questions, with a pass mark of 65%. To enable you to gain experience in answering this type of question paper all of the Assignments to this course take that form. By this means it is possible to cover a wide spread of subject matter in a short period of time. This Revision Assignment asks questions based on the matters we have covered so far and is typical of the questions you may be asked in the actual examination.

There are 50 questions, which should take you less than half an hour to complete, whereas in the exam you will be allowed 1 hour to complete 100 questions. If you find it takes you longer than the 30 minutes, which is unlikely, you will need to speed up but do not worry at this stage. The intention of the course is that you learn and remember the subject matter and that you gain the confidence to attempt this type of question paper. As the course progresses there will be further revision units in this style and you will find that as your knowledge and confidence grows, and further practice is gained the time taken will shorten.

Each question has three or four alternative answers, only one of which is correct. Select the answer you consider to be the right one and tick the appropriate box. Do not refer to the earlier course units but complete this Assignment from memory. Looking up the answers to gain good marks will only be cheating yourself as the marks gained here are of no value other than to enable you to judge how you will fair in the exam and to show you the matters you need to revise.

PLEASE ANSWER ALL OF THE FIFTY QUESTIONS. It is suggested you approach the paper in the following way.

- 1) Read through all of the questions, you will find you immediately know the answers to some of these.
- 2) Now work through the paper ticking those answers you are sure about, passing over those about which you are not so sure. You will be surprised how doing this will focus your mind and, once you have adjusted to this, other answers will start coming to mind.
- 3) Go back to the start looking at those questions you left unanswered. Read the question again, as by now your mind will have settled and adjusted to the task in hand. Tick the remaining boxes as necessary.

- 4) If you find it helpful makes notes or short calculations on the side of the question paper. They will be ignored by the tutor (as they will be by the examiner in the actual examinations) but keep them clear of the answer boxes so as not to confuse them with your answers.
- 5) Scan through the entire paper again clearly making any corrections you feel are necessary.
- 6) Be sure you have ticked only one answer for each question. If you have changed your mind, make sure the tutor can easily identify your selected answer.

Return the assignment for marking. When this is returned to you from the tutor, look at any questions that are marked as incorrect. Spend a little time revising those matters, even if this means reading through the work unit again.

It is better if you make revision an ongoing routine rather than leaving it as a last minute pre-exam rush. Last minute revision rarely helps and indeed often serves to confuse, whereas knowledge built up over a time and well learnt is seldom forgotten. So set some time aside for regular revision. Only you can judge how much time is required and what matters you need to consider based on your performance during the course and, in particular, with the Revision Assignments.

If you find you are having difficulty with a particular matter and that having re-read the unit text you still do not understand, speak to your colleagues at work. Those experienced testers and examiners and those who have previously passed the examinations should be able to guide you. If, having made every effort yourself you still find you have a particular difficulty, then a short note to the tutor will get you some guidance. In this case please remember that the tutor's time is at a premium as he/she has well over a hundred other students to deal with. Whilst always willing to help, the reply may be short and may also be delayed. They will only be able to direct you to the text, so it is far better if you can resolve the problem yourself.

Good luck with the Assignment, remember - attempt this without reference to the training material, other text or other persons. The only object is to enable you to gauge your progress and identify the matters you need to revise.

UNIT NO. 1.11

COMPONENTS

In this unit we will consider links, rings, hooks and similar components that are used in the assembly of general purpose slings and can be found fitted to lifting machines. The fittings and components we deal with here are intended for assembly and fitting to chain, wire rope and textile materials, although there may be differences in some cases for specific lifting media. In certain circumstances some of these items may be used on their own as part of a rigging arrangement.

The series of Harmonised European Standards, BS EN 1677, covers components for slings and has separate parts specifically for hooks with latch, grades 8 and 4, self locking hooks grade 8 and links, grades 8 and 4. These standards control the general design and manufacturing criteria to be applied by the manufacturer, but give the opportunity for manufacturers to adopt their own designs, material specifications and material sizes. As a result, whilst the items produced by individual manufacturers have much in common, they do differ in sizes and sections as permitted within the manufacturing windows of the standard. It is therefore necessary to consult the specific manufacturer's catalogues and technical literature for detailed information.

FORGING

The components we are concerned with in this unit are produced from steel by forging. In most cases the items are drop forged but hand forgings, especially of links and special items, are also commonly found in service. We considered this in unit 1.4, but will run through the main points again here.

In the case of drop forging, a billet of steel is heated to working temperature and then held between a split die of the required item. The top half of the die is fitted to a drop hammer and the bottom half is attached to a fixed anvil. Under power the top die drops onto the billet, hammering the heated metal into the die. This process is repeated until the final shape of the item is achieved.

The excess material is forced out of the die where the two halves come together. Subsequently this 'flash' has to be dressed off. It is easy to recognise a drop forging by the dressed line that runs around the centre line of the finished section.

For some components it is necessary to take the billet through a series of dies until the final item is completed. However, the fewer strikes of the hammer that are necessary the better and the lower the risk of introducing defects.

In the case of links, some manufacturers produce them by drop forging whilst others hand forge the link by bending a bar to shape and then welding the joint. In yet other cases there is a combination of the processes. The initial bending of a bar is made by hand forging and welding, with the finishing to size being by drop forging.

COMMON FORGING DEFECTS

Although the forging process is basic, and looks crude to the casual observer, it calls for great skill from the operator if forging faults are to be avoided. The types of defect that occur during manufacture are therefore much the same, irrespective of the component

being produced. The tester and examiner must be alert to these when making an examination of any forged component.

Gall marks are an over lapping of the material during working which is closed into the material below welding temperature. Under load they will open up and act as stress raisers, eventually becoming cracks.

Laminated material will again act as a stress raiser which will eventually crack. This is often difficult to detect as its appearance will differ with its position and the methods of working applied to the material. Often it will look like a discoloured line running along or across the item.

Cracks can occur in several ways in addition to those mentioned above, the most common occurring during heat treatment when over stressed material is quenched too quickly. They can also occur due to chemical contamination, eg with acids or acidic gasses.

Weld faults must be considered when looking at welded rings and links. Weld cracks can develop during manufacture or in service. Other manufacturing weld faults are lack of penetration, appearing as a lap between the weld and the parent material, undercutting, gas blow holes and slag inclusions. These may be difficult to identify in links which have been welded before the final forging process.

Gouges and incomplete section can occur from careless handling during forging. A gouge will appear as a groove or score line in the material. If insufficient material is placed in the dies the full shape and section of the component will not be formed.

Burnt material occurs if the forging temperature is exceeded. The material will take on a glazed or crystalline appearance and may develop a high number of hairline cracks.

Multiple and offset stamping occurs if the item is moved during the drop forging process. Drop forging is a highly skilled art calling for the billet to be held firmly and steadily in position. If the billet from which the forging is to be made is not held correctly in the dies, or if it is moved between strikes of the hammer, misshapen components will result. There are various forms that this type of defect can take, although they are obvious during an examination.

COMMON IN SERVICE FAULTS

In addition to the common forging faults, mentioned above, the examiner must also look for the following in service defects when making an examination.

Wear – The maximum permissible wear for an item with a curved or circular cross section is an 8% reduction of the nominal diameter or a 10% loss of material for other sections. However this assumes that the wear is even. Wear is obvious to see and the tester and examiner must use his judgement cautiously. If wear is not the only consideration, he will often find he is removing items from service long before the limit is reached.

Burring or bruising and material movement – As the material begins to wear, or is subjected to shock loading and/or vibration, it may move or flow. If this is severe, cracks

will form appearing in a similar manner to a chisel head that has been struck several times and burred over. No material movement should be permitted on items being returned to service.

Distortion and Deformation – Sideways twisting, bending, closing in, opening up, elongation and similar distortion and deformation are all grounds for immediate rejection.

Nicks, cuts and gouges– These defects, caused by careless handling, all act as stress raisers and will eventually lead to cracking and thus are grounds for immediate rejection. (Note: In some cases this type of defect, if minor, may be shallow and be capable of being dressed out using a fine file. This is acceptable provided that it can be done without reducing the material diameter to the wear rejection point or introducing stress raisers).

Corrosion and chemical attack – Any corrosion should be treated with caution and should be cleaned off prior to the examination. Should there be any resulting pitting this will act as a stress raiser and lead to cracking. The alloy steels used in lifting gear manufacture are subject to hydrogen embrittlement and associated hairline cracking if they are subject to exposure to acids or acidic fumes. Great care is therefore needed during the examination and such items must be removed from service.

RINGS

Rings were once the most common master (head) fitting for slings. They were also used for other purposes from time to time, such as fitting through the eye of an eyebolt to remove the need for the use of a shackle. Over the last decade or two their use has declined in favour of links, and they are seldom used nowadays.

One of the reasons for this is the advance in technology, which has seen the use of alloy steels expand greatly. This advance has resulted in a general reduction in the sizes of hooks etc with which slings must connect, even so a vast amount of older equipment, particularly cranes, remain in service which have a lower grade, and therefore larger, hooks and fittings. The problem with rings is then one of size compatibility, which is largely overcome by the use of links, eg a 120mm wide link will sit on a deep section hook that a 120mm diameter will not be capable of.

Another important reason for their decline is safety. A ring can freely turn in use and, if the ring is welded, the position of the weld cannot be guaranteed. The weld could therefore be placed in a position of high stress. Again this problem is generally overcome by the use of a link. Due to the foregoing problem, it is considered that the use of welded rings in new equipment does not meet with the essential safety requirements laid down in the European Machinery Directive (Supply of Machinery {Safety} Regulations in the UK).

Despite the foregoing, rings are still worthy of our consideration as a large amount of older equipment remains in service which is fitted with rings and they may be found on special items. These will usually be grade 40, 4 or (M), but occasionally grade 60 or (S) may be found, particularly in mining, and former mining, areas. However, it should be noted that BS EN 1677 does not specify requirements for rings.

Two different proportioned rings are shown in figure 1. The most severe loading of a ring is due to a load (w) being applied diametrically. Many years ago, stress analysts found that a ring with an internal diameter (D) greater than $2.55 \times$ the diameter of the material

(d) from which it was made behaved as if it were a simply supported beam. The maximum tensile stress (s) occurs at the extreme layers of the extrados in the line of the load. Most sling master rings are in this condition.

They also found that, where the internal diameter (D) was less than 2.55 x the diameter of the material (d) from which it was made, it behaved as an encastre beam. The maximum tensile stress (s) is at the extreme layers of the intrados at right angles to the line of the load.

D is greater than 2.55d

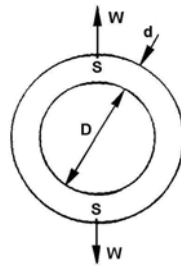

D is less than 2.55d

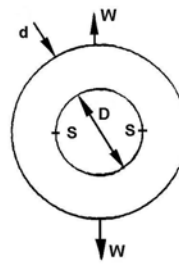

S = position of maximum stress

Figure 1
Maximum Stress in Rings

Knowing the point of maximum stress is important to the tester and examiner as it is here that defects will be most likely to occur. However, it must be emphasised that the term thorough examination means just that and knowing the point of maximum stress is not a justification for limiting the examination. As they can turn in service, any part of the ring may have been at the point of maximum stress whilst in use.

Grade 40, 4, M, 60 and S rings can be cut and welded, or hand forged and welded, and repairs can be carried out by any suitably equipped workshop. It is important to note that rings require hardening and tempering following welding and subsequently a proof load test at WLL x 2 must be made to prove the integrity of the work.

LINKS

Links have replaced rings in the assembly of slings for the reasons already outlined. Although solid drop forged links are available from some manufacturers, the majority are welded. As well as master links for slings we must also consider small, often hand forged, links that are used to connect the legs of welded construction chain slings to the master link, or are fitted to eyebolts and similar items, as the principles outlined here are the same.

In the case of master links intended for chain sling assembly, the link section may be flattened to increase its depth and/or permit narrow jawed coupling components to be fitted to them. Often only a small area on one of the sides of a link is flattened, or further flattened, to allow narrow jawed coupling components to be fitted.

The weld in a link should always be positioned centrally in one of the straight sides. This will ensure that the weld never sits on the hook or mates with other components and that

it remains in a low stressed part of the link. This requires special attention during the examination as the flattening mentioned above will often be in the area of, or opposite, the weld.

A link can be considered as a point loaded beam, the sides forming the supports, whilst the curved portion is the beam. Figure 2 shows two differently proportioned links which, like rings, act differently under load.

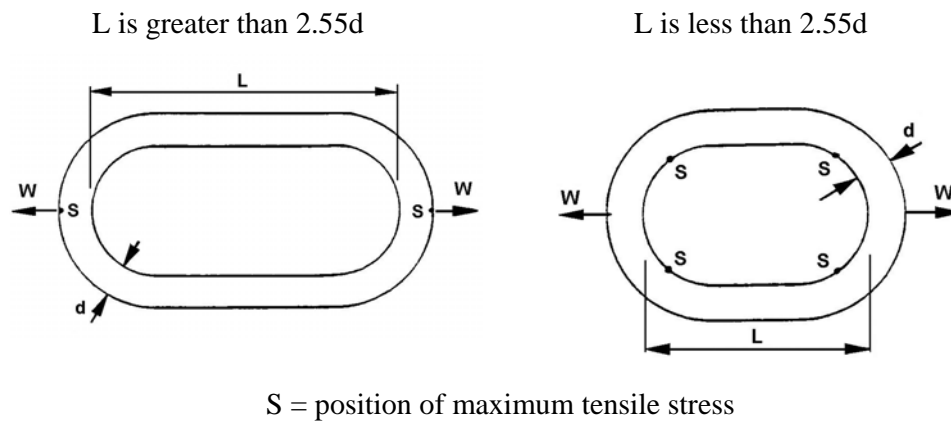

Figure 2
Maximum Stress in Links

Links behave in a similar way to rings, where L is greater than $2.55d$ the maximum stress occurs at the extreme outer layer (extrados) on the crown. Most sling master links are in this condition. Where L is less than $2.55d$ the maximum stress occurs in the extreme inner (intrados) at the ends of the straight sides. Intermediate links, joining links and links fitted eyebolts are usually in this condition.

Virtually all grades of links may be found in service and grades 4, 8 and 10 are commonly available from manufacturers for sling assembly or similar uses.

In the case of grade 8 or grade 10 links conforming to BS EN 1677-4, they will have been proof load tested at the time of manufacture, or verified by other means permitted by the standard. The proof load applied is a minimum of $2.5 \times WLL$ and up to 70% of the radii will usually be supported during this test to prevent the link from collapsing. No alterations, cutting and welding should be carried out to these grades of material and damaged links cannot be repaired.

Grade 40, 4, M, 60 and S links can be cut and welded and repairs can be carried out by any suitably equipped workshop. It is important to note that links require hardening and tempering following welding and subsequently a proof load test at $WLL \times 2$ must be made to prove the integrity of the work.

EGG LINKS

Egg links are so called because they are of an oval shape in profile, resembling that of an egg or pear, with a large diameter at one end and a smaller diameter the other. They were once common in use, either as the terminal fittings to collar chain slings, where one end

can reeve through the other for use in choke hitch, or fitted to collar eyebolts to enable hooks to be attached without the need for a shackle.

They may still be available in grades 8 or 10, with an integral clevis through, which the chain is fitted so that their position is guaranteed but in all other cases their continued use should be questioned on the grounds of safety. Similarly to a ring, they can easily turn in service. If they invert so that the smaller end seats on a hook, the hook will be too wide causing the link to deform and/or crack across the weld. It is therefore considered that egg links do not meet with the essential safety requirements of the Machinery Directive (Supply of Machinery {Safety} Regulations in the UK).

HOOKS

Not so long ago nearly all of the hooks seen on lifting equipment were of trapezoidal section. The British Standard, BS 2903, covering these was withdrawn some years ago and it is left to manufacturers to adopt their own designs within the parameters of BS EN 1677-2, -3, and -5. It is now rare to find hooks of trapezoidal section in use with lifting gear, except in special circumstances or when dealing with older in service equipment. Even so the general principles of hook design are well established and are followed by the manufacturers.

The maximum tensile stress occurs at the extreme layers of the intrados, at right angles to the line of pull, and at the greatest distance from it. Figure 3 shows four typical hooks. The long line passing through the hook indicates the line of pull and reaction. The small curved line with arrow heads indicates the position of maximum stress.

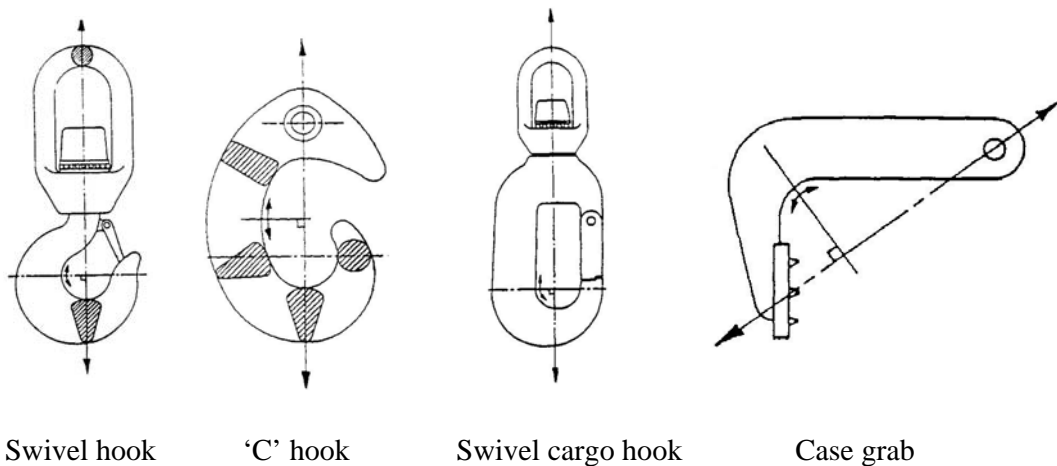

Figure 3
Examples of Hooks

Hooks are designed so that, should they be over loaded, the hook will open slowly and transfer the point of maximum stress onto a slightly larger cross section. In this way the hook actually becomes stronger when it opens, so slowing the failure and giving the operative a clear visible warning.

You are advised to look at as many examples of hooks as possible and to study manufacturer's and supplier's literature, to familiarise yourself with different hook designs and their uses.

CONCLUSION

In this unit we have considered various fittings used for the assembly of slings and used with winches and hoists. Although some of you will be employed in the statutory examination of user's in-service equipment, and therefore encounter various types and grades of these fittings, most will be in the position of only seeing those of grade 8 and grade 10.

UNIT NO. 1.12

CHAIN SLINGS

Although, load for load, chain slings are the heaviest type of sling they remain very popular for general lifting applications. This is largely due to their robust nature as they are less liable to damage than slings of other materials. Even so correct selection for the duty and environment in which they are to be used and stored is essential if they are to remain undamaged.

In previous units we considered chain and components used for sling assembly, some details of which you will be expected to recall in your studies here. In the context of grade 8 and grade 10 chain slings we will also look at coupling devices, which are a further form of component for slings.

At one time certain types of chain sling were made from, or included, long link chain. It should be noted that the European Machinery Directive only permits the use of short link chain for lifting purposes and therefore the use of long link chain is prohibited.

Modern chain slings are assembled from components which have mechanical fixings, such as spiral roll pins, to retain them. Older chain slings, and currently a few for special applications, were assembled by a blacksmith and had welded joining links.

Although, in theory, both methods of assembly may be applied to any grade of chain, in practice it will be found that only grade 4 are generally produced by welding and grades 8 and 10 by mechanical assembly. In certain circumstances grade 8 welded slings may be produced, but their use is rare.

** In early 1997, BS EN 818-4 was issued covering alloy steel chain slings manufactured or assembled from grade 8 chain complying to BS EN 818-1 and 2. Previously an international standard was the basis for slings that were mechanically assembled from grade T chain to BS 4942: Part 5. Students may therefore find some older reference material and documentation for slings that refer to grade T. For our study purposes at this time we can consider the requirements to be the same and use the designation 8 where applicable in this text. We should also note that it will be some years before all the existing grade T slings come to the end of their working life and this will have to be borne in mind when conducting examinations.*

WELDED CONSTRUCTION SLINGS

Once very common, welded chain slings have now become rare, with only one or two companies left that are able to produce them. They are supplied as specials for applications where higher grades of chain cannot be used. Even so a number may still be found in service, so calling for the tester and examiner to have an understanding of them.

Welded construction chain slings are assembled from standard chain and components, eg drop forged rings, links and hooks, using joining links made by a blacksmith, which then have to be welded. Links alternative to rings and special fittings also have to be welded. A welding process, known as atomic hydrogen welding, gives very acceptable results and is used for this purpose. As both the material structure of the blacksmith made and welded

items has been affected by the manufacturing processes, corrective heat treatment is necessary. Either the complete assembly is treated or, where the facility exists, the joining links may be treated in a link heater.

Heat treatment furnaces are large and expensive to operate, therefore to make the operation economically viable it is necessary to wait until there are sufficient items to fill the furnace. Hardening and tempering is a two stage operation, usually carried out on successive days. It can be seen therefore that considerable delays can occur from the time of order placement until a sling is ready for use. Although the use of a link heater can shorten the time, the manufacture of welded slings is still a lengthy process.

Welded chain slings must be individually tested on completion of manufacture or repair in order to test joining links and previously untested components.

From the 1950's to the mid 1970's the majority of chain slings produced were grade 40 welded construction, recognised by the quality mark 04 or 4 dependent on whether the sling was hardened and tempered or normalised.

The chain used complied with the 1950 British Standard BS 1663 and the sling assembly was covered by BS 2902: 1957. These were imperial standards, which were replaced by the metric equivalent, Grade M to BS 4942 Part 2 1981. This in turn has been superseded by BS EN 818-3 Grade 4 1999. Here we should note that apart from minor dimensional differences, due to metrication, there are two other differences between the standards. The FOS required by the imperial standards was a minimum of 5:1 whereas the metric standards require 4:1. Further, the metric standards require hardening and tempering as the only form of heat treatment.

There is still a limited demand for grade 4 slings in specific industries and situations where the alloy steels cannot be used for technical reasons, eg in acidic environments. However they have many disadvantages, so do not get used for general purposes. They are, however suitable for special applications, where alloy steels, eg grade 8, cannot be used.

Welded chain slings can only be repaired by a suitably equipped workshop, of which there are very few. They require blacksmith, atomic hydrogen welding and heat treatment facilities. Damaged links and components have to be cut out and replacements fitted with new joining links. The repaired sling must be heat treated and a proof test made before the sling can be returned to service.

Up until the late 1970's another grade of welded chain sling was available, Grade 60. This never proved popular for general slinging purposes. It was mainly used by the mining industry. A very limited number of grade 60 chain slings may still be found in service and can be recognised by the grade 60 quality mark, 06.

Although BS EN 818-4 allows for the manufacture of grade 8 welded slings, it is unlikely that the average tester and examiner will ever find examples of these in service. There are considerable technical difficulties that have never been fully overcome. Further, time and cost make it an uneconomic alternative to mechanically assembled slings. Some examples, from mainland Europe, may be found in offshore applications. It should be noted that, in this case, repairs should only be attempted by the original manufacturer as special techniques are necessary and any incorrect welding or heat treatment will cause cracking.

Although less than 1% of the slings made today are of welded construction, grade 4 still has a small role to play. They are suitable for use in arduous conditions, such as foundries, galvanising and pickling plants, where the grade 8 slings cannot be used due to high temperatures, which cause softening, and contact with acids, which causes hydrogen embrittlement.

MECHANICALLY ASSEMBLED SLINGS

The history of the mechanically assembled sling is very short compared to that of the welded sling, but it is very much a success story. For well over 30 years now nearly all of the chain slings supplied in this country have been mechanically assembled grade 8 (originally known as grade T). Although not yet covered by the standards, grade 10 has entered and established itself in this market. The popularity of mechanically assembled slings is due in no small part to the ease with which they can be assembled and repaired as well as the weight savings.

The production of a mechanically assembled sling is an easy operation. Only very basic skills and a few simple tools are needed for the assembly. Standard master links and an extensive range of fittings are available which can be assembled onto chain quickly using special couplers or clevis and load pin arrangements on the component itself. This means that a mechanically assembled chain sling can be produced in minutes as opposed to the days required to manufacture and heat treat a welded sling.

There are several chain and chain sling system manufacturers. The range of fittings available is extensive. Although similar, the methods of assembly vary slightly between the different systems available. You are advised to study as many of the manufacturer's sales leaflets as possible so as to become conversant with them. However, as the principles are the same, we can consider mechanically assembled chain slings here in a general way.

When this method of sling assembly was first introduced no standards existed for the chain that was used. An alloy steel chain known as grade 75 was used. Rapid development saw the introduction of grade T which quickly replaced it. Should the examiner find slings with the grade 75 marking in service he is advised to recommend replacement with the slightly stronger grade 8.

The current standard for grade 8 chain is BS EN 818-2. Grade 8 is twice as strong as grade 4, used for welded slings, therefore great weight savings are made. The further advance to grade 10 shows even greater weight to load ratio savings. To ensure compatibility with existing crane hooks and for additional safety reasons, all of the mechanical chain sling systems use links, as opposed to rings. They have the advantage of greater depth allowing them to be fitted onto large hooks and, unlike a ring, will not turn in service, so avoiding the load being imposed across the weld.

Even though mechanically assembled chain slings have been available and in common use for many years, until the introduction of BS EN 818-4 there was no British Standard covering them. Sling assemblers therefore assembled slings to the manufacturers' instructions which themselves took an international standard into account.

We should also note that, although there are as yet no standards for it, higher grades of mechanically assembled sling systems are appearing on the market. Grade 10 has been

around for a few years now and even higher grades are being developed. These grades offer WLL's between 25% and 50% higher than grade 8. The tester and examiner must be alert when making examinations to identify the chain grade correctly, ensure that there has been no mixing of grades and ensure the sling has been correctly marked.

TYPES OF MECHANICAL ASSEMBLY FITTINGS

Components with Clevis Connection

Figure 1 shows a typical hook with a clevis.

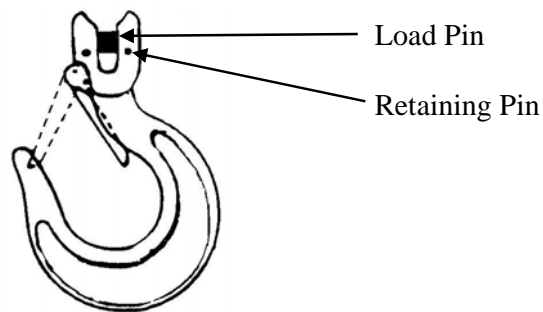

Figure 1

A full range of fittings is available with the clevis form of chain connection, such as hooks, shackles and egg links. This system of assembly minimises the number of components necessary to assemble a sling, as the terminal fittings locate directly onto the chain. For the connection of the chain to master links a simple shackle like coupler is available in some systems.

With clevis attachment the end link of the chain is passed into the jaw of the clevis. A load pin is passed through the clevis and chain, on which the chain seats. Spiral roll pins or circlip type fixings are used to lock the load pin in position. For some mining applications a rivet, the second head of which is formed by a rotary action-riveting machine and not a hammer action, replaces the spiral pins.

Couplers, in a similar form to a horseshoe shaped shackle, having a similar load pin arrangement for attachment to the chain, are available in some systems.

Coupling Assembled Components

Figure 2 shows a coupling component. The coupler is in two halves with a central pin and retaining collar.

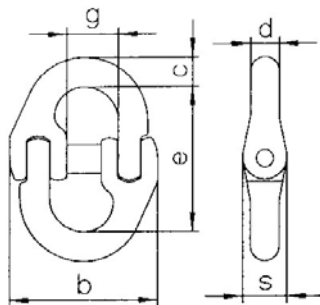

Figure 2
Coupling Component

Some systems employ fittings with large eyes through which half a coupler is passed; the other half of the coupler is passed through the end link of the chain. Couplers are available for chain to chain, chain to eye type fitting and chain to master link attachment.

The two halves of the coupler fit together and a locking/load pin passes through the centre to hold them together. The locking pin is kept in position by a central retaining collar, spring clips or circlip type fixings. Figure 3 shows the assembly procedure for a coupling component.

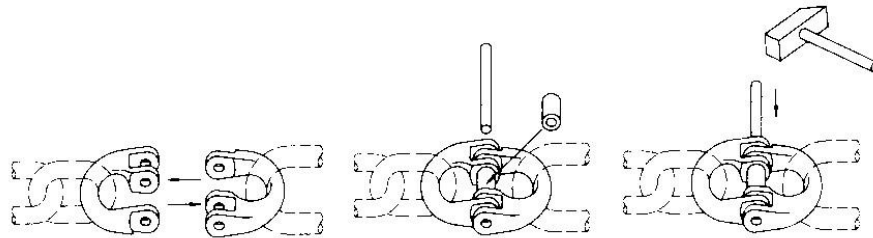

Figure 3
Coupling Component Assembly

You are advised to obtain as many different manufacturers catalogues as possible and study the range of fittings available as well as the assembly methods employed.

General

Mechanically assembled chain system components are supplied by the system manufacturer in the hardened and tempered condition. As the assembly of the sling does not affect the material condition no further heat treatment is necessary, indeed it would be positively dangerous.

The components are also verified by an appropriate method and certified by the manufacturer. Assembled slings do not therefore need to be proof tested, but only thoroughly examined to ensure that they are correctly assembled and that no damage has occurred during handling and assembly. Indeed, with a system in compliance with the relevant standards, it is not possible to test a made up sling without damaging it beyond use.

RATING CHAIN SLINGS

There are two methods of rating multi-leg slings, the trigonometric method and the uniform load method. Older general purpose slings may occasionally still be found rated by the trigonometric method. However, since the publication of BS 6166 in 1986, it should be reserved for use on single purpose slings, ie slings that will and can only be used in one way, such as the top chain of a spreader. The uniform load method should be used for all general purpose slings. Whilst this has been the recommendation since 1986 the practice has not always been followed, the uniform load method is the only method specified for general purpose chain slings in BS EN 818-4, therefore they must be rated this way.

Section 13 of the LEEA Code of Practice for the Safe Use of Lifting Equipment gives a detailed explanation of these methods in relation to chain slings. The student should study this so that he is able to recognise the method applied to the item he is examining and be aware of the advantages and limitations of both methods.

TESTING CHAIN SLINGS

Although mechanically assembled chain slings to BS EN 818-4 cannot be proof load tested without damaging them, or the test will reveal nothing that was not already known, welded chain slings still require proof load testing following manufacture or a repair. Even though

very few, if indeed any, students will need to test chain slings there are one or two important points we should note.

In the case of welded construction chain slings, it is necessary to carry out a proof test after initial manufacture or any repair in order to verify the joining links and any fittings used which may not already have been verified.

In the case of BS EN 818-4, requirements for force/load testing are given which are intended as the initial, once off, manufacturer's test, for welded construction grade 8 slings. The loading plan given (figure 4) is similar to that for other uniform load rated slings (figure 5), but higher forces are applied which are equivalent to 2.5 times the WLL. This test is not intended to be repeated or be applied to mechanically assembled slings. Indeed, if the sling system is truly in accordance with the uniform load method and complies fully with the standards, there is a very real risk that the master link will be damaged beyond use by such a test.

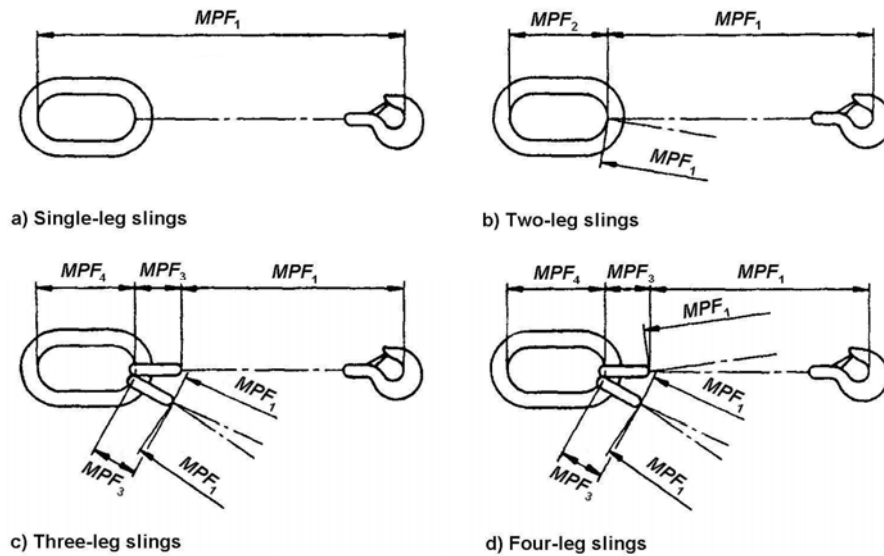

Figure 4
Proof Test Loading Plan for Grade 8 Slings to BS EN 818-4

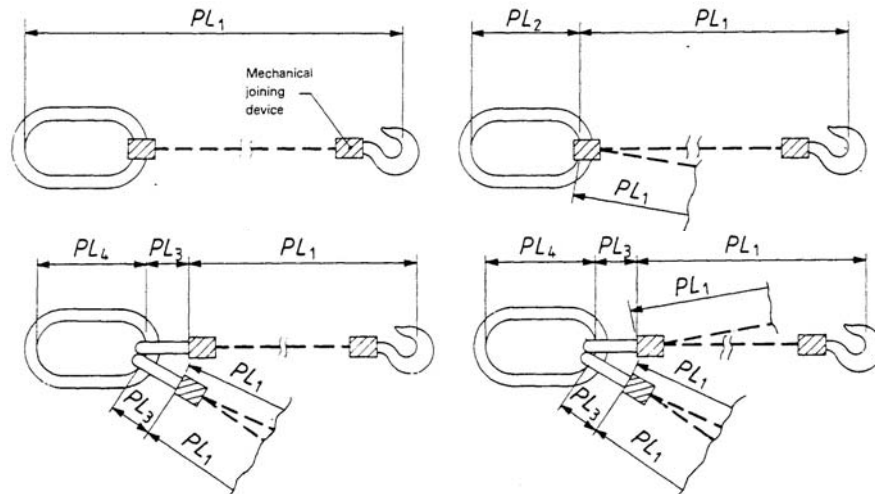

Figure 5
Proof Test Loading Plan for Uniform Load Rated Slings
other than to BS EN 818-4

MANUFACTURER'S (ASSEMBLER'S) DOCUMENTATION

In the case of a new sling, the assembler (manufacturer) is required by the European Machinery Directive (Supply of Machinery {Safety} Regulations in the UK) to issue an EC Declaration of Conformity. BS EN 818 calls for a 'manufacturer's certificate'. In fact there is little difference between these two documents and they are easily combined into one. So as not to confuse the user with a myriad of different documents, and for other administrative reasons, many companies prefer to retain these documents in their 'technical file' and issue a report of thorough examination in accordance with LOLER.

In either event, it is essential that the sling manufacturer has complete traceability for the chain and components used. The items used in the sling assembly should be listed as part of the sling description. The report should also show the WLL. For multi-leg slings this should be expressed at 0-45° to the vertical and, if additionally required by the user, at 45°-60° to the vertical.

When a repair is made, it is essential that the repairer has full traceability in his job file for the parts he has fitted. On completion he must make a thorough examination and issue a report of thorough examination in accordance with LOLER.

MARKING

The marking may be on the main ring or master link. Often this is not practicable, in which case it should be on a tag fitted to the upper terminal fitting in such a way that it does not obstruct the free movement of any part of the sling or become damaged when the sling is in correct use. If the latter method is used, the identification number of the sling, which is traceable to the records, should also be marked on the upper link or ring so that if the tag is lost the information can be retrieved.

The usual method of marking is by hard stamping, etching/engraving is also sometimes used. Whichever method is used, if the marking is directly onto the master link care must be taken to ensure that it is in a low stressed part of the link and that it does not impair the mechanical properties of the link.

The following information should be given:

- (1) Identification mark
- (2) Safe working load, in the case of multi-leg slings this must include the rated angle or range of angles*.
- (3) The grade mark
- (4) Any other information called for by the standard being worked to:
eg BS EN 818-4 calls for the manufacturer's or assembler's name or symbol to be given and, in the case of multi-leg slings, the number of legs must be stated.
- (5) The CE mark if applicable.

****Special Note:***

Traditionally, in the UK we rated, marked and certified multi-leg slings referring to the included angle between the sling legs, eg 90°, or range of included angles, eg 0-90°. As you will have seen from your studies and reference to the Code of Practice for the Safe Use of Lifting Equipment, the calculations for the resultant loads in the inclined legs of a sling on which this is based are made on the angle that the individual leg makes to the vertical, the included angle being twice that.

BS EN 818, and all of the Harmonised European Standards for slings of other materials, take a different approach, the rating and marking being expressed at the angle of inclination, ie the angle of the leg to the vertical. It will be appreciated that in marking a grade 8 sling in accordance with BS EN 818-4 the WLL will then be given at the angle of inclination to the vertical, eg 0-45°, ie half the included angle. It is therefore advisable that a tally or tag is used which includes a pictogram so that the user will understand the basis for the rating and marking.

The various chain sling system manufacturers supply suitable tallies for use on grade 8 and 10 slings. LEEA document 025 dated 13 August 1998, offers further advice on this and you are advised to obtain a copy of this from your office. You are also advised to read the LEEA guidance notes on the repair and re-verification of mechanically assembled chain slings, which were issued at the same time.

THE USE OF CHAIN SLINGS

Before we consider the matters to be taken into account during the examination we will take a look at the use of chain slings and the damage and defects that can occur due to misuse. Full details of the safe use of chain slings are given in Section 13 of the LEEA Code of Practice for the Safe Use of Lifting Equipment, which you should also study.

Slings must not be used to lift loads greater than the marked SWL, taking account of the slinging mode and resultant loads that may be imposed. Unintentional overloading where these matters have not been taken into account is one of the more common causes of stretching of sling legs.

Not only must the sling be compatible with the lifting appliance, it must also be compatible with the load and any other lifting accessories in the lifting arrangement, both in capacity and physical size. The master link should seat correctly in the hook of the appliance and articulate freely to avoid deforming the link. In the same way, the load, or its attachments, must seat in the sling hooks, never on the point, and allow the hook to align to avoid opening the throat or deforming the hook.

Chain is designed to support a load in a straight line. Care is necessary to ensure the sling is not twisted, or worse, knotted. Where chain is tensioned across an edge or corner it must be suitably packed. If these simple measures are ignored the chain will be over stressed locally, resulting in stretched, bent or broken links.

Hooks of multi-leg slings must be positioned to face outwards or the load will sit on the point, which will lead to overloading the hook and opening the throat. If placing the hooks back onto the master link to form a basket hitch, the link must be large enough to accept the hook without overcrowding fittings and components as this will lead to distortion and/or bruising and gouging.

If a sling is to be used in choke hitch, the parts of the sling should be placed in the natural 120° angle, or they will slide to that position. Neither must the sling bight be tightened by hammering into position. This will cause stretched or bent links and, in the worse case, cracked welds.

Shock loading must be avoided otherwise the sling, or parts of the sling, will be grossly overloaded causing stretch or distortion.

Care must be taken when landing the load to ensure it does not sit or trap the chain. This can cause stretched, bent or otherwise damaged links.

EXAMINING CHAIN SLINGS

Chain slings fall under the heading of 'lifting accessories' in modern legislation and therefore should be examined by a competent person at periods not exceeding six months. Nothing will be achieved by a load test of mechanically assembled slings, either during the initial or in-service examinations, as the strength is known prior to the examination. Indeed such a test to mechanically assembled slings to BS EN 818-4 will be damaging.

In discussing the examination of chain slings, whilst most of the examination procedure will be the same, we must be aware of the differences that generally apply between welded and mechanically assembled slings. It is important that the tester and examiner is able to determine how the sling he is examining is assembled and rated. Welded chain slings must be heat treated on completion of manufacture, or after repair, and subsequently be proof load tested. In this case, the report of thorough examination should show the details of the loads applied. This is not the case with grade 8 or 10 mechanically assembled slings. A thorough visual examination must be made to ensure they are correct assembly and that all locking devices are correctly in place.

During the examination of chain slings the following should be checked:

- 1) The chain should articulate freely.
- 2) The maximum permissible wear is 8% reduction in material diameter for the chain, components and fittings.
- 3) The maximum elongation, mainly due to seating and interlink wear, is 5%.
- 4) Unless the sling is specifically designed otherwise, the legs of multi-leg slings should be of equal length so that the seat of hooks, or bearing point of other fittings, is equal. This is an important matter to check, particularly if a leg of chain has been replaced, as the pitch may vary from the original.
- 5) There should be no signs of bending, twisting or other distortion to the chain, master link or other fittings. Particular attention is necessary at the point of choke.
- 6) There should be no signs of nicks, cracks, corrosion or chemical attack.
- 7) Hooks should show no signs of opening or of distortion and, where fitted, safety catches should be undamaged and operate freely.
- 8) Marking should be clear and legible; it must give all of the necessary information for the particular grade and type of sling.

UNIT NO. 1.13

WIRE ROPE SLINGS

Wire rope slings are very popular for general lifting duties; however they are more susceptible to damage than chain slings. They have the advantage that, due to their rigidity, they can be easily passed under loads when slinging. As with any lifting media, slings of all configurations can be assembled from wire rope and will be found in service. Those working in the offshore industry will be familiar with the 'five leg' slings attached to offshore containers. These are actually a four legged wire rope sling with a pendant sling attached to the master link. However, by far, the majority of wire rope slings in service in general industry will be found to be single leg.

In previous units we considered wire rope and components for slings, some details of which you will be expected to recall in your studies here.

Wire rope slings are now manufactured to BS EN 13414-1: 2003, Steel wire rope slings – Safety – Slings for general service, but prior to its introduction, BS 1290 was the standard that was used. There are two major differences between these standards which we should note as they will affect us during an examination and when we consider replacement slings.

The rating of slings in BS EN 13414-1 takes account of the termination efficiency before applying a factor of safety of 5:1, whereas BS 1290 applied this factor to the rope before the eye was made, thus reducing the FOS by 10-20%. As a result, to obtain the same SWL for a replacement sling a larger diameter rope is usually necessary. Where both rope size and SWL are critical this problem can be overcome by using a higher grade rope, eg 1960 grade.

The other difference we should note here is that BS EN 13414-1 calls for multi-leg slings to be rated and marked with their WLL expressed in terms of the inclination angle to the vertical, eg 0-45°, whereas BS 1290 called for the marking to be shown at the included angle, eg 0-90°.

EYE TERMINATIONS

Single slings are produced by taking a length of wire rope and forming an eye at each end. Multi-leg slings are made in exactly the same way except that the eyes at the top of the sling are made through a master link. If terminal fittings are required, these can be attached by making the eye through the fitting. To help the eye keep its shape and to give the rope protection a thimble (BS EN 13411-1) is used. This is often known as a 'hard eye' and this is advised when fittings are to be made onto the sling as permanent attachments. Winch wires and many terminal ends of hoist ropes also incorporate eyes.

We can see then that the making of eyes is very important to us. There are two ways that eyes can be made, ferrule secured (sometimes incorrectly referred to as a mechanical splice) and hand spliced. BS EN 13414-1 does not specify how to make these eye terminations, but requires them to be made in accordance with BS EN 13411-2 and 3.

Ferrule Secured Eyes

There are two ways that ferrule secured eyes can be formed, the turn back loop and the Flemish eye. BS EN 13411-3 gives the requirements, including the verification necessary, for both of these methods.

Turn back loop

The turn back loop is the cheaper option to manufacture and therefore is perhaps used more commonly for general purpose slings. With this method, an aluminium ferrule is used to secure the eye made in the end of the rope.

The eye is simply formed by passing the ferrule over the rope, bending the rope back on itself to form the eye, pulling the ferrule back over the returning tail end of the rope and then pressing the ferrule. Under pressure the aluminium flows into the rope formation, making a homogeneous joint.

When square cut ferrules are used, in order to ensure that the rope is fully engaged within the ferrule it is necessary for a small amount of the tail to protrude through the ferrule. The standard says that the length of this should be no more than one half of the rope diameter. However, if the rope has been cut by a heat process a portion of the rope will have become annealed (softened) in the heat affected area. The protruding tail in this case should be no more than an amount equal to one diameter of the rope, and positioned so that none of the annealed section is within the ferrule.

Tapered ferrules are also available from some manufacturers. In this case the tail end remains within the ferrule and it is essential that the ferrule manufacturer's instructions for fitting are followed. Often, the manufacturer of the ferrule will provide a small view hole in the ferrule to enable the tail end to be seen.

A simple loop in the wire, with no protective thimble, is known as a soft eye. BS EN 13411-3 requires the length of the soft eye (h) to be at least fifteen times the diameter of the rope and the width ($h/2$) to be half the length of the eye, see figure 1.

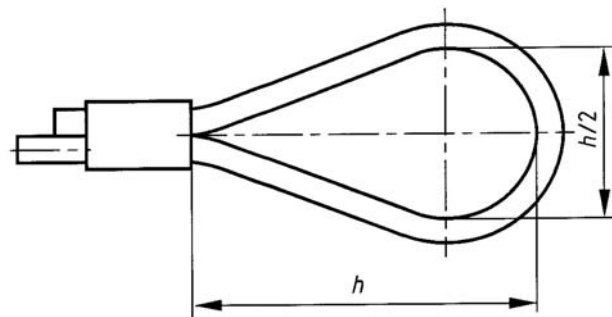

Figure 1
Turn Back Loop with Soft Eye

Where a thimble is fitted to give the rope protection from wear and damage, and to help the eye maintain its shape, it is important that there is a clearance between the end of the thimble and the ferrule after it is pressed; but it is also important that the thimble is secured and cannot rotate or roll out of the eye.

Flemish eye

This method of making an eye actually produces a stronger securing than the turn back loop, ie the termination is more efficient. It takes longer to produce and is therefore more expensive. In this case a steel tapered ferrule is used to secure the exposed ends of the rope.

To make a Flemish eye, a tapered steel ferrule is passed over the rope. The standing part of the rope is then taken and three strands are unravelled and opened so that a 'Y' formation is made. Care has to be taken to ensure that the strands still lay together as they had in the rope.

The leg of the 'Y' that includes the core is bent to form an eye so that the ends of the strands sit against the undisturbed part of the rope at the bottom of the 'Y'. The remaining three strands are then re-laid into the rope in the opposite direction, taking up the position they originally had in the rope so that the lay of the strands is not disturbed. The ends of the strands are then evenly distributed around the intact standing part of the rope to complete the eye. The ferrule is then slid back over the distributed wires without displacing the strands and then pressed. In this case the ferrule compresses and grips the rope. See figure 2.

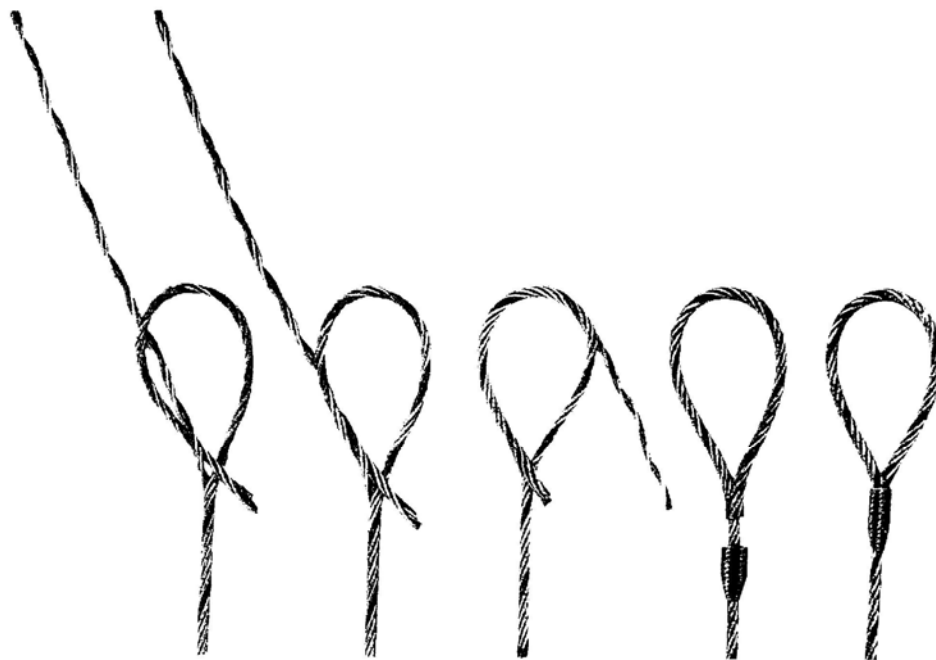

Figure 2
Forming a Flemish Eye

The minimum peripheral length of a soft eye should be four times the rope lay length. This is so as to ensure that the lay of the rope is not disturbed.

It is extremely difficult to fit thimbles when making Flemish eyes. A protective attachment, known as a stirrup, is therefore more commonly used. See Figure 3.

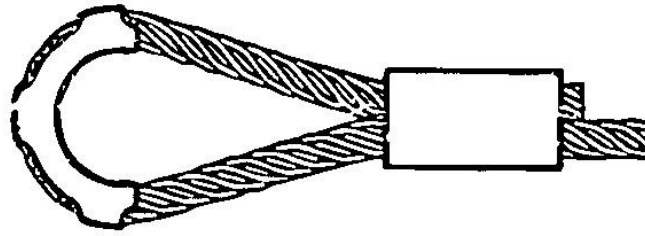

Figure 3
Eye Fitted with a Stirrup

Spliced eye

Splicing is the old method of making eyes in wire ropes, and slings with spliced eyes were once common. Splicing is a labour intensive process and so is mainly used nowadays for slings for special applications or ropes for uses other than for slings. Even so slings with spliced eyes can occasionally be found in service. The requirements for spliced eyes are given in BS EN 13411-2.

The rope is bent to form an eye. The strands in the end of the rope are separated and then tucked back into the standing part of the rope against the lay. This is done in such a way that they lock and do not slip when a load is applied. There must be at least five load carrying tucks. At least three of these must be made with the full strand and the remaining tucks with at least 50% of the wires. This is known as a 'Five Tuck Splice' or sometimes as a 'Docks Splice'.

Although care is taken to tuck the strand tails back into the rope, a number of wire ends may still protrude from the rope. To avoid a hazard of catching, or cutting hands, the splice is then covered. This can be done by serving the rope with a soft wire or twine or by heat shrink wrapping.

A well formed 'five tuck' splice will tighten into the rope when a load is applied, which increases the efficiency of the splice. The tester and examiner must however be alert to a form of splice, known as the 'Liverpool Splice'. In a Liverpool Splice, the strands are tucked into the body of the rope with the lay and it will open up and release the load if the rope or load is allowed to rotate. The 'five tuck' splice is therefore the only type of splice acceptable for lifting applications.

ENDLESS SLINGS

Endless wire rope slings can be produced by either ferrule securing or splicing. If ferrule secured, two ferrules must be used. They must be at least three times their own pressed length apart. In the case of splicing, a five tuck splice must be made each side the joint.

TWO PART SLING LEGS

Although not mentioned in BS EN 13414-1, another method is sometimes used to produce sling legs, known as two part sling legs. It is not a very common way of producing sling legs, but is used for very large capacity slings, so the tester and examiner needs to be aware of it.

An endless sling is produced, as above, and then a thimble is bound at each end, as shown in figure 4.

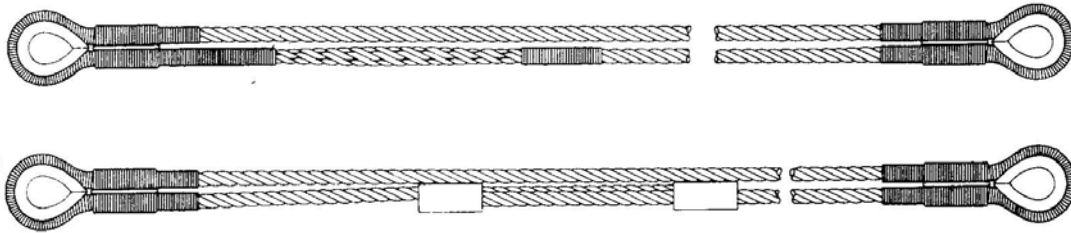

Figure 4
Two Part Sling Leg

The thimbles that are used must be two or three sizes larger than would normally be used for the rope diameter. The looped sling leg will take a greater load than a single part sling made from the same size rope and a thimble for the actual rope diameter would collapse under the increased load it has to take. In order to make the thimble fit the rope it is necessary to serve the rope with wire or spun yarn.

A sling leg produced by this method is not capable of twice the WLL of a single part of the rope, as one might expect, but is in the order of 25% less than this. This is due to the increased stress due to the rope being bent around such a tight radius.

As this method of producing sling legs is not covered by standards, the manufacturer must produce a full technical file in order to comply with the requirements of the Machinery Directive. His instructions for use, maintenance and examination must be sought and followed.

RATING WIRE ROPE SLINGS

Multi-leg wire rope slings to BS EN 13414-1 are rated by the uniform load method. It was also the method used for slings to BS 1290; however, the way of expressing the WLL is different. BS 1290 adopted the UK traditional way of expressing this as SWL at the included angle, eg SWL 1t 0-90°, but BS EN 13414-1 expresses it as WLL at the inclination angle to the vertical, eg WLL 1t 0-45°.

As mentioned at the start of this unit, BS EN 13414-1 gives the WLL for the made up slings which takes the efficiency of the splice or joint into account before the WLL is calculated. This was not the case with BS 1290 which merely applied the 5:1 FOS to the breaking load of the rope.

TESTING WIRE ROPE SLINGS

BS 1290 required the sling manufacturer to carry out a proof load test on all sling legs, other than spliced legs, at twice the WLL. In real terms this was a rather pointless test as a badly made ferrule secured eye, or even one utilising the wrong size ferrule, would often hold the proof load. BS EN 13414-1 has a very different, but perhaps more meaningful, verification regime relating back to the other standards used.

The rope must be confirmed as being the correct construction, diameter and grade and this must be checked against the rope supplier's documentation. The WLL of links and terminal fittings must be checked against the supplier's documentation to verify the correct

WLL and grade. The ferrule secured eyes or splices must be checked in accordance with the respective standard covering them.

In the case of ferrule secured eyes BS EN 13411-3 requires the verification of ferrules and ferrule secured eyes to be made at various stages. The correct selection of the ferrule for the particular rope size must be checked against the ferrule manufacturer's instructions and documentation. The forming of the eye must be checked against the requirements of the standard by visual examination and measurement. The pressing of the ferrule is verified by visual examination and the finished dimensions of the ferrule confirmed against the manufacturer's instructions and a table given in the standard.

This may need a little explanation. The dimensions of an un-pressed ferrule are known and matched to the appropriate pressing dies and wire rope size. It is therefore known what the correct dimensions of the pressed ferrule will be. If the wrong size ferrule and/or dies are used the length and diameter of the pressed ferrule will vary. Checking this is a far better way of ensuring the joint has been made correctly and will be capable of entering service safely than putting a load on which might not reveal these matters.

MANUFACTURER'S DOCUMENTATION

In the case of a new sling, the manufacturer is required by the European Machinery Directive (Supply of Machinery {Safety} Regulations in the UK) to issue an EC Declaration of Conformity. BS EN 13414-1 calls for a 'manufacturer's certificate'. In fact there is little difference between these two documents and they are easily combined onto one. So as not to confuse the user with a myriad of different documents, and for other administrative reasons, many companies prefer to retain these documents in their 'technical file' and issue a report of thorough examination in accordance with LOLER.

In either event, it is essential that the sling manufacturer has complete traceability for the wire rope, ferrules and components used. The items used in the sling assembly should be listed as part of the sling description. The report should also show the WLL. For multi-leg slings this should be expressed at 0-45° to the vertical and, if additionally required by the user, at 45°-60° to the vertical.

When a repair is made, it is essential that the repairer has full traceability in his job file for the parts he has fitted. On completion he must make a thorough examination and issue a report of thorough examination in accordance with LOLER.

MARKING

The marking may be on the master link, a ferrule or a suitable metal tag. Where a tag is used it is recommended that the master link or a ferrule is also marked with the identification marks so that, if the tag is lost the information can be retrieved.

The usual method of marking is hard stamping, etching/engraving is also sometimes used. Whichever method is used, if the marking is directly onto the master link or a load bearing ferrule care must be taken to ensure that it is in a low stressed part of the link and does not impair the mechanical properties of the link or ferrule.

The following information should be given:

- 1) Identification mark

- 2) Safe working load, in the case of multi-leg slings this must include the rated range of angles
- 3) Any other information called for by the standard being worked to (eg BS EN 13414-1 calls for the manufacturer's identifying mark to be given)
- 4) The CE mark if applicable.

CAUTION

Wire Rope Grips (Bulldog Grips)

For many years it has been common practice to make temporary eyes in wire rope, particularly winch wires, by using clamp type grips, commonly known as bulldog grips. This practice has always been questionable as the safety of the resulting eye has depended on several variable factors, ie the number of grips used, the spacing of the grips, which way round they are fitted and their tightness. These factors are heightened by the fact that a wide range of types and patterns of grip are freely available on the market and have often been fitted by untrained persons.

As the result of a series of accidents and dangerous occurrences The Health and Safety Executive Research Laboratories began a test programme in 1985, the British Standards Institute issued an advisory notice amending their recommendations and LEEA suggested limitations on their use.

The Health and Safety Executive concluded their tests in March 1991 and this resulted in the immediate withdrawal of BS 462. We must therefore carefully consider the use of wire rope grips and it is worthwhile paying attention to some of the obvious, less obvious and implied results of the laboratory tests. Although the tests were limited largely to 16mm diameter wire and grips, selective tests were made on other sizes and several hundred tests were made in all. The evidence is such that we can conclude similar results would be obtained for all sizes.

The first item of interest to us is the grips themselves. These were ordered from various suppliers around the country, the orders specifying wire rope grips to BS 462: 1983. In fact none of the grips complied with this standard and were found generally to be to the withdrawn 1958 version. They were however truly representative of what is available on the market and found in general use. To obtain consistent comparative results, all of the tests were carried out on the same machine using the same measuring equipment and in all but a few cases the grips were fitted by the same experienced, trained rigger. Comparative tests were made using various proprietary grips and grips to the German specification DIN 1142.

Details of the first series of tests are not given in the report as the results varied so much as to be meaningless. These set out to establish when visible slip occurred. Several people witnessed the tests and recorded when they observed movement to first occur. Their opinions differed so greatly that the tests were abandoned and subsequent tests were made using measuring equipment to determine micro slip, that is the point at which the tail end of the wire starts to slip through the grip, although not visible to the naked eye.

All gripping or clamping devices rely on the tightness of the nuts for their efficiency. Although BS 462 did not give any recommendations for torque DIN 1142 and most manufacturers of proprietary grips do. It was found that, with the exception of the DIN specification grip, it was either impossible or impracticable to tighten the nuts sufficiently in normal conditions. Indeed with some grips the recommended torque could not be attained with the grips clamped in a vice and an extended lever fitted to the spanner. At the average practical torque efficiency of the grips was found to be in the order of 20% - 30%. When the torque was increased by restraining the grips in a vice the efficiency improved to 40% - 50%. These figures could be further improved by fitting 4 instead of the recommended 3 grips but at a practical torque still only achieved efficiencies in the 30% to 40% range.

When the grips are first fitted some loss of torque occurs. Although this is unexplained bedding down of the wire and core is no doubt a factor. Tests show that in the early stages this loss is rapid but tends to stabilise after several days even so some loss still occurs after many weeks and seems to be ongoing. The surprise here is that grips fitted one day and left with no load applied were found to loosen over night, when checked the following day a 50% loss of torque was measured in some cases.

The DIN 1142 standard recommends that the threads of the clamp and nut should be greased prior to fitting. When this practice was applied to the BS 462 grips better results were achieved. This is probably explained as the applied torque acting on the gripping of the rope rather than wasted in overcoming friction in the threads. In practice this seems to be done in only a few cases as riggers find the grease transfers to their hands and tools and can lead to dangerous working conditions.

The tests show that once slip occurs it is ongoing. It can be concluded that this is related to loss of torque for, as with loss of torque, slip in the initial period is at a far faster rate. After a period of time the rate of slip slows considerably but never stops.

Several other factors affect the results. The spacing of the grips recommended in BS 462 was at six times the diameter of the rope. This was found to be correct. At this spacing the rope recovers its full diameter between each grip. If the grips are placed closer together the rope remains flattened to some degree as the result of the clamping action therefore making movement easier.

It was found that self colour (ie ungalvanised) grips gave better results than galvanised. Similarly if the rope was bright rather than galvanised the results improved.

The construction of the rope also plays a big part in the improvement of the result. Results obtained with wire cored ropes were far better than with fibre cored rope. Unfortunately the tests did not study this aspect in great depth but the results also imply that Ordinary Lay rope gives a better result than Lang's lay.

Several other factors, the reasons for some of which remain unexplained, were revealed. In all of the tests thimbles were fitted to the eyes and, to prevent the thimbles collapsing, a bush was inserted in the thimble. This may explain why in all of the tests where broken wires were found in the joint length they occurred under the grips nearest to the tail end. In no case were broken wires found under the grip nearest the thimble. The breaks occurred at the intersection of the two parts of rope and were probably due to the crushing and cutting action caused by the clamping of the grip.

Better results were achieved when the tail end was sealed with soft wire. PVC tape and other means of binding the tail allowed the rope to unlay. It is also implied that a preformed rope would maintain its shape better than a non preformed rope.

Grips with grooved saddles performed less well than grips with plain saddles. It was found that in no case did the rope sit in the grooves of saddles and as movement occurred there was a tendency for the grooves to be worn down leading to some loss of torque and further slip.

The biggest surprise is the wide variation of results when the eyes were made by different people, ie where eyes were made by experienced, trained riggers using the same grips in comparative tests. The torque was checked to the same setting yet the eye made by the rigger who was used for all of the other tests had a far greater efficiency than the others. This implies that even though the torque setting was the same some other latent variation in the fitting technique affects the result.

In the comparative tests most of the commonly available types of wire rope grip and clamping devices were tested. Only one was found to perform as expected, the DIN 1142. The required torque was attainable in practical conditions and when fitted fully in accordance with the specification gave an efficiency of approximately 80% ie the required efficiency. It should however be clearly noted that in Germany the DIN Standard prohibits the use of the grip in lifting applications.

The HSE report made certain recommendations on the use of grips which the tester and examiner must take into account when conducting thorough examinations and offering advice to the user.

The British Standard BS EN 13411 Terminations for steel wire ropes Part 5:U-bolt wire rope grips was introduced in 2003. This standard gives the fitting instructions, torque and number of grips required and the safety requirements for the use of wire rope grips.

(A) Use of grips

- (1) Always seek alternative methods of terminating the wire and forming eyes, eg ferrule secured, wedge sockets etc.
- (2) Where use of wire rope grips cannot be avoided use only grips to BS EN 13411-5:2003.
- (3) Serve tail end of rope with soft wire.
- (4) Follow the recommendations with regard to the number of grips and torque value.
- (5) The saddle of the grip should be in contact with the live part of the rope and the 'U' bolt should sit on the tail end.

(B) Examination of existing assemblies that utilise grips

- (1) Examine the general overall condition of the termination
- (2) Check the correct number of grips has been used and that they are correctly fitted.
- (3) Examine the rope for broken wires paying attention to the area adjacent to the grips.
- (4) Look for any visual signs of movement of the rope through the grips.
- (5) Check and if necessary reset the torque of all nuts. In this respect look for evidence of periodic re-torquing.

COMMON DEFECTS IN WIRE ROPES AND SLINGS

Let us look at some specific defects that may occur in wire rope and consider their affects on the rope.

Kinks - These occur in a wire rope or sling due to improper handling. A kink starts from a loop in the wire and although it is possible to occur in normal service, it is usually found during the handling of the wire rope prior to it going into service. A loop, which has not been drawn tightly enough, can easily be removed by turning the rope in the correct direction to restore the lay. If however, the rope is pulled with the loop still present then permanent structural damage occurs and the rope is irreparably damaged at that position. A kink of this nature can result in a 25% reduction of the Breaking Load.

Not only does the kink reduce the strength of the rope but it also accelerates wear and fatigue failure due to the distortion in the axis of the rope. Undetected this can lead to a very serious accident.

To avoid kinks during the handling of the rope the following points should be observed:

- (a) Small coils of wire rope can be unrolled along the ground, but must always be kept under control.
- (b) Larger coils should be mounted on a turntable or have the reel rotating on a horizontal shaft mounted on stands or jacks. When taking off from the reel always keep a slight tension in the rope and pull off in a straight line.

Lubrication - Regular and correct lubrication of wire ropes is essential to preserve the internal as well as the external condition of the rope.

Ropes are supplied with internal lubrication and most have also been externally treated. After a period of service, they must be again treated with an approved neutral (non-acid) lubricant. Modern fibre cores cannot be relied on to act as lubricant reservoirs.

Thinner types of lubricant have the best properties but if the rope is subject to severe environmental conditions, eg seawater, heavier and thicker types of lubricant are more suitable, eg dredging. For operation in normal outdoor conditions a medium lubricant is found satisfactory.

Before application of the lubricant, the wire rope should be clean and dry, (paraffin should not be used for cleaning). Heavy and medium types of lubricant are heated before application to ensure maximum penetration.

Fatigue - The wires of a rope can become brittle and ultimately break due to bending back and forward when passing over drums and on to pulleys or even in the case of slings due to being bent over sharp corners. Fatigue in the outer wires is often associated with

excessive wear and is also set up in the inner wires due to bending and the rubbing of one wire on another, particularly when the rope lacks lubrication. Fatigue is particularly liable to lead to failure when it is associated with rust or other forms of corrosion. It cannot be detected by examination but must be allowed for in assessing the serviceability of the rope; signs such as excessive wear, kinks and general bad conditions make the rope suspect.

When a wire breaks due to fatigue, the fracture when examined under a magnifying glass will be sharp across the wire at right angles, whilst in fracture due to tension the broken ends will be drawn to a point. Examples of Fatigue and tensile failure are shown in figure 5.

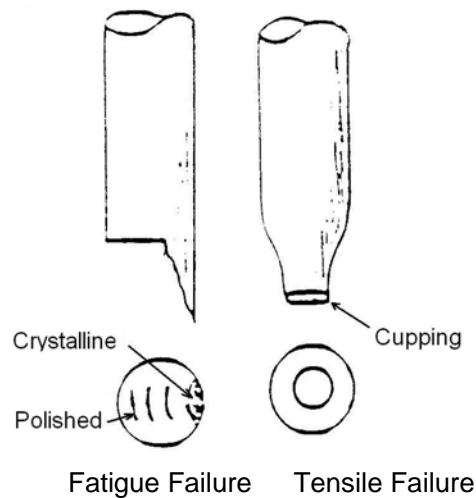

Figure 5
Appearance of Fatigue and Tensile Failure

Wear and Corrosion - It is obvious that the strength of a wire rope is continually being reduced during service, owing to the action of abrasion, bending, corrosion and other factors. Inspection is necessary at regular intervals throughout the service in addition to the periodic examination and the observer must keep in mind the fact that the safety of the rope depends upon its continuing strength.

The only practical method is to observe any marked reduction in the diameter of the rope, indications of excessive abrasion on the outside wires, and broken outside wires. Usually reduction in diameter is due to external wear or corrosion, but occasionally, due to lack of lubrication, the inside wires and core may be damaged, and when such internal deterioration exists the rope must be considered to be in a serious and dangerous condition. It follows that any marked reduction in rope diameter must be fully investigated and its cause definitely determined. For example, a localised reduction in rope diameter may be due to a collapsed or broken core, caused by an overload.

When corrosion is present, the remaining strength of a rope cannot be calculated with safety. This being the case, it is essential that corrosion must at all times be controlled by correct and adequate lubrication.

NB With some constructions of rope the presence of internal corrosion may be indicated by an increase in the rope diameter. Therefore any changes in rope diameter must be fully investigated.

THE USE OF WIRE ROPE SLINGS

Before we consider the matters to be taken into account during the examination we will take a look at the use of wire rope slings and the damage and defects that can occur due to misuse. Full details of the safe use of wire rope slings are given in Section 14 of the LEEA Code of Practice for the Safe Use of Lifting Equipment, which you should also study.

Slings must not be used to lift loads greater than the marked SWL, taking account of the slinging mode and resultant loads that may be imposed. Unintentional overloading where these matters have not been taken into account is one of the more common causes of damage to slings.

Not only must the sling be compatible with the lifting appliance, it must also be compatible with the load and any other lifting accessories in the lifting arrangement, both in capacity and physical size. Master links and eyes should seat correctly in the hook of the appliance and articulate freely to avoid deforming the link or eye. In the same way, the load, or its attachments, must seat in the eyes or terminal fittings, eg sling hooks.

The effective diameter of pins, hooks or other components over which soft eyes are placed should be at least twice the diameter of the rope, four times in the case of double part sling legs. Where necessary an intermediate component of suitable size should be used to ensure this. If this is not done the rope in the eye will be crushed or deformed and the core will become exposed.

If more than one sling is being used, they should be joined by a shackle before being placed onto the hook. This will prevent the hook becoming over crowded so that one sling sits on another, again this will result in the rope in the eye becoming crushed.

Under no circumstances must slings made from rope of different lay directions be joined together. This will cause the rope to unlay and become distorted.

Wire rope performs best when it supports a load in a straight line. Slings should be positioned correctly when placed around loads, eg in choke or basket hitch, to form as large a radius as possible. Under no circumstances should the radius formed be less than four times the rope diameter. Suitable packing should also be used. If this is not done the rope will be permanently kinked, crushed or, at worst, cut. In any event a sling that is repeatedly taken around corners and then loaded will take on a set, this may make the sling difficult to handle but will only be harmful if other damage is done to the rope.

Ferrules and splices should always be positioned in the free standing part of the sling; otherwise they will be crushed, deformed or otherwise damaged when the load is taken.

Shock loading must be avoided otherwise the core or inner wires will become damaged.

EXAMINING WIRE ROPE SLINGS

Wire rope slings fall under the heading of 'lifting accessories' in modern legislation and therefore should be examined by a competent person at periods not exceeding six months. Nothing will be achieved by a load test of wire rope slings, either during the initial or in-service examinations, as the strength is known prior to the examination. Indeed such a test to a sling that has been in service may be damaging.

During the examination of wire rope slings the following should be checked:

- 1) Damage, wear and distortion to master links and terminal fittings, including protective thimbles, eg opening of hooks, ineffective safety catches, bent master link etc.
- 2) Mechanical damage to the rope, fittings, splices or ferrules such as cuts, nicks and gouges. Fittings and ferrules should be examined for signs of cracking.
- 3) Broken wires. A small number of well distributed broken wires will have no effect on the capacity of the sling, but are a danger to the user when handling the sling. In some cases it will be possible to break them back so that they lie within the strands. If they are found to be in a cluster the cause should be investigated to establish if this would continue if the sling was returned to service.
- 4) Corrosion or drying out of the lubrication, particular care being paid the inner section of the rope.
- 5) Kinks or other permanent set. This must be viewed critically; some bending or setting is inevitable. Providing the rope is not damaged in any way and can still be handled safely it may re-enter service. Kinks, however, are more serious. The rope may have been flattened, the core become damaged or exposed, or wires may have been broken.
- 6) Disturbance to the position of wires in strand or strands in rope or a protrusion of the core.
- 7) Heat damage which is visible as melted lubricant, blueing of wires, weld splatter, evidence of arcing etc.
- 8) Marking should be clear and legible; it must give all of the necessary information required by the standard or legislation.

UNIT NO. 1.14

SHACKLES

Shackles are probably the most common and universal lifting accessory, their uses are extensive. They may be used to connect a load directly to a lifting appliance, for the connection of slings to the load and/or lifting appliance, as the suspension for lifting appliances or as the head fitting in certain types of pulley blocks. The LEEA Code of Practice for the Safe Use of Lifting Equipment, Section 18, deals with shackles and you should refer to this as part of your studies.

Although the old British Standards BS 3032, BS 3551 and BS 6994 have been withdrawn and/or declared obsolescent for several years, overseas manufacturers and their importing agents still make shackles generally to BS 3032 available. The current Harmonised European Standard for forged steel shackles for general lifting purposes is BS EN 13889:2003, which is a standard for Dee and Bow shackles grade 6.

Shackles to the American US Federal Specification RR-C-271b are extremely popular and, in practice, it will be found that the vast majority of shackles in use today comply with its requirements. This is largely as a result of the influence of the oil industry. It is very similar to the Harmonised European Standard and the shackles would meet this standard.

In this unit we will refer to the various standards in a general way, but refer to BS EN 13889 for specific detail, as the requirements for the tester and examiner are generally the same, irrespective of the standard to which the shackles were manufactured. As with eyebolts, it will not be far in the future when an International Standard will be issued, which will permit most of the shackles currently available within its manufacturing window.

NOTE: Older shackles to US Federal Specifications call for greater care, as the design requirements may have varied greatly. In this case it is essential that the manufacturer's specific advice is followed both for examination and for use. Current versions of Federal Specification RR-C-271b align to international requirements but older versions, prior to the mid 1980s', were very different. Although you are unlikely to still find any in service it is worth noting a few matters. In many cases the marked SWL was based on the jaw of the shackle being filled, ie the load acting over the full width of the pin. The proof load may have been as low as SWL + 10% with deformations as great as 10% allowed, provided the pin still fitted. As a result of the very different design criteria used in the older versions, and that some were marked in US (short) Tons, these shackles often appear to be stronger than similar sized shackles to other designs, when in fact they may well be weaker! The information in this unit does not therefore apply to such shackles. Reference must always be made to the manufacturer's original documentation and instructions should you by some rare chance be required to examine them.

MANUFACTURE

Body and Pin Forging

Shackles are produced by forging. US Federal specification, and similar, shackles are usually drop forged, identifiable by the flash line around the body, whilst old British Standard shackles are bent from bar billets and therefore show no flash marks. In either case the body must be in a single piece and there should be no welding. Harmonised Standard BS EN

13889: 2003 allows for both methods, it says:

‘Shackle bodies shall be forged hot in one piece. Excess metal from the forging operation shall be cleanly removed leaving the surface free from sharp edges. After heat treatment, furnace scale shall be removed.

Profiling of blanks other than by bending and forging shall not be used.

Shackle pins shall not be produced by a casting process.

No welding shall be carried out on any part of the shackle body or pin.’

Heat Treatment

After forging, but prior to machining and finishing, shackles are hardened and tempered.

Finish

Shackles are supplied in various surface finishes, depending on the standard to which they are made and BS EN 13889 permits many of these, eg descaled, electroplated, hot dip galvanised or painted.

TYPES OF SHACKLE

Bodies

There are two types of shackle body, the Bow and the Dee see figure 1.

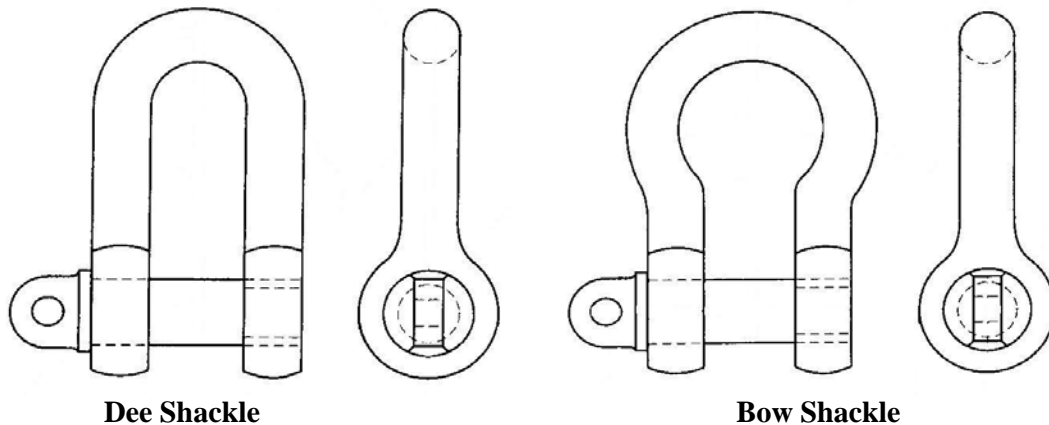

Figure 1
Types of Shackle Body

Dee shackles are generally intended for joining two items in a straight line, whereas Bow shackles are designed to enable three or more items to be joined. As a result, Bow shackles are usually used when it is necessary to connect a number slings to the hook of a lifting appliance.

NOTE:In the case of shackles generally to the old British Standards 3032 and 3551, were denoted by the diameter of the body. Other standards, including BS EN 13889 denote shackles by their working load limit.

Pins

There are two types of shackle pin in common use, the screw pin and the bolt, nut and cotter pin, see figure 2.



Figure 2
Types of Shackle Pin

Whilst BS EN 13889 specifies and gives relative dimensions of the above pins it also permits other suitable forms of pin head within the specification.

Screwed pins with eye and collar are the most common type of pin and are suitable for a wide range of uses, however, if they are subject to movement and vibration, eg by a sling moving over the pin, they can loosen and unscrew.

The bolt with hexagon head, hexagon nut and split cotter pin is used where a positive connection is required as it cannot unscrew unintentionally. They are also ideal where a permanent connection is required, eg connecting the top slings to a spreader beam.

MARKING

BS EN 13889 requires that each shackle is legibly and indelibly marked with the following information, by the manufacturer, in a way that will not damage the mechanical properties of the shackle:

- a) Working Load Limit in tonnes
- b) Grade mark
- c) Manufacturer's name, symbol or code
- d) Traceability code

It also requires that pins of less than 13mm diameter are marked with either the grade mark or the traceability code and pins 13mm diameter or above are marked with the grade mark, traceability code and manufacturer's symbol.

Although the standard does not specify where the marking should be made, in order to meet the requirement not to impair the mechanical properties of the shackle, this must be in a low stress part, eg the straight portion of the standing leg, and not around the crown.

STRESS IN SHACKLES

A shackle is carefully designed so that the strength of the body and pin are approximately equal. In order to achieve this, the pin will be of a larger diameter than the body. The pin acts as a beam. If it is subject to a point load, it will be both in a condition of bending and of double shear. If the jaw is fully filled, so that the load is spread evenly over the full width of the pin, it will only be in double shear.

For a point load, the maximum tensile stress occurs at the centre on the outward facing side of the pin. Standards assume that the pin will be subject to a point load, as this is worst condition, when calculating the pin diameter.

For a uniformly distributed load, the maximum tensile stress will occur at the same position,

but will only be half the value of that of a point load. This does not mean that the shackle will be stronger and capable of a higher WLL, as the stress in the body will remain the same. Dependent on the proportions of the shackle body, the maximum stress may occur either at the outside on the crown of the body or at the inside of the sides of the body as shown in figure 3.

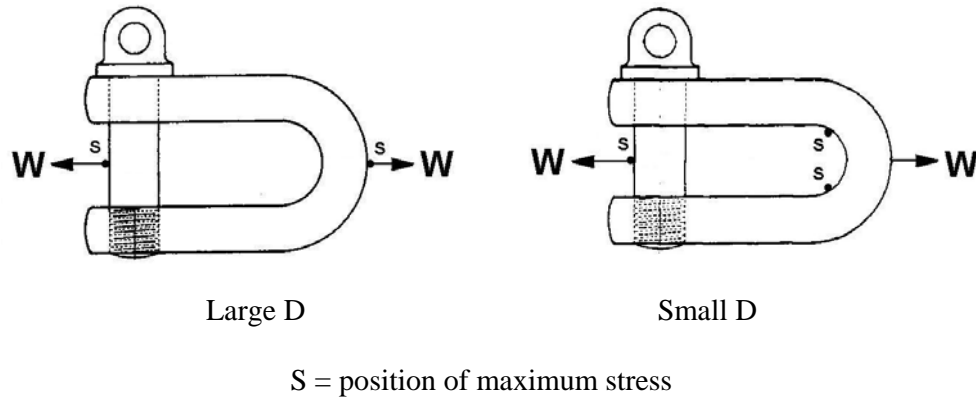

Figure 3
Position of Maximum Stress in Shackles

STRENGTH OF SHACKLES

The strength of a shackle depends on five factors:

- 1) The material from which it is made and its heat treatment.
- 2) The diameter of the material of the shackle. The larger the diameter of the shackle body the stronger it will be for a given inside width.
- 3) The diameter of the material of the pin. Similarly, for a given width in the jaw of the shackle, the larger the diameter of the pin, the stronger the pin will be.
- 4) The width of the jaw. For a given size of shackle material, the wider the jaw and the greater the diameter inside the bow, the weaker the shackle will be.
- 5) The inside diameter of the bow where this differs from the width of the jaw.

MANUFACTURER'S TESTS

Type Tests

To prove the design, material, heat treatment and method of manufacture, and to ensure that the shackles possess the necessary mechanical properties, BS EN 13889 requires that the manufacturer makes certain type tests. The type tests have to be repeated if there is any change of design, specification of material, heat treatment or method of manufacture. The type tests to be made are:

- a) Test for deformation on three samples
- b) Static tensile test on at least three samples
- c) Fatigue test on three samples
- d) Charpy impact test on test pieces taken from at least three samples

Manufacturing Tests and Examination

The manufacturing tests required by BS EN 13889 are different depending on the quality management system operated by the manufacturing company.

Manufacturers with an accredited EN ISO 9001 certification

If the manufacturer has a quality system conforming to EN ISO 9001 certified by a certification body accredited to EN 45012 the following tests and examinations must be made:

Proof load test

If the production batch is between 1 and 3000 off, they must proof load test 3% of the batch. This decreases to 2% for batches of 3001 to 5000 and to 1% for batches of more than 5000. A manufacturer may elect to operate an alternative test regime of 2% of all his production, irrespective of the size of the batches. The proof load applied is twice the WLL.

Non-destructive test

After heat treatment and de-scaling all bodies and pins must be subjected to magnetic particle or dye penetrant examination.

Visual examination

All shackles must be visually examined. The examination can be carried out on the completed shackles or in stages during the production provided that all relevant features are examined.

Manufacturers without an accredited EN ISO 9001 certification

If the manufacturer does not have a quality system conforming to EN ISO 9001 certified by a certification body accredited to EN 45012 the following tests and examinations must be made:

Proof load test

All of the production batch must be proof load tested to twice the WLL.

Static test and Charpy impact test

One sample per production batch must be subjected to a static test and three samples must be subjected to a Charpy impact test.

Non-destructive test

After heat treatment and de-scaling all bodies and pins must be subjected to magnetic particle or dye penetrant examination.

Visual examination

All shackles must be visually examined. The examination can be carried out on the completed shackle or in stages during the production provided that all relevant features are examined.

THE USE OF SHACKLES

Before we consider the matters to be taken into account during an examination we will take a look at the use of shackles and the defects and damage that can occur due to misuse. Full details of the safe use of shackles are given in Section 18 of the LEEA Code of Practice for the Safe Use of Lifting Equipment, which you should also study.

The correct shackle body and pin must be used and they must be of the same grade. Accidents have occurred where the user has put a mild steel pin in an alloy steel body or

replaced a screw pin with a nut and bolt.

The shackle must be compatible with all of the other fittings in the slinging arrangement, taking account of increased resultant loads due to angular loading, and it must seat correctly with mating parts. If the shackle jaw is too small it will be forced open and/or bent and if it is too wide the shackle may twist under load and take on a permanent set.

Shackles should be loaded along the axial plane of the body sides or the body, and possibly the pin, will be bent, see figure 4.

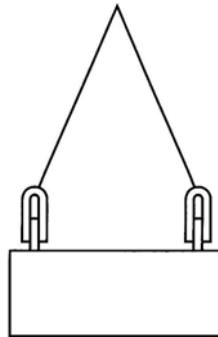

Figure 4

The pin must be correctly screwed into the shackle eye, ie finger tight and locked using a small tommy bar, so that the collar of the pin is fully seated on the shackle eye. The pin must be the correct length so that it penetrates the full depth of the screwed eye and allows the collar of the pin to bed on the surface of the drilled eye with only 1 or 1½ turns of thread remaining exposed in the jaw. Where shackles are fitted with a bolt and pinned nut, the length of the plain portion of the bolt should be such that the nut will jam on the inner end of the thread and not on the eyes of the shackle, thus leaving the bolt free to rotate. If these steps are not taken there is every chance that the body of the shackle will be closed in and permanently deformed when the pin is tightened.

Shackles which have a positively locked pin, eg bolt, nut and split cotter pin, should be used for applications where the shackle cannot be observed or where the pin may unscrew when in service and, in the worst case, release the load. The pin will become scored and gouged if it has been unscrewing, even by a small amount, under load and this will lead to stress raisers.

Eccentric loading will cause the shackle to twist so that the load comes onto the angle formed by the body and pin, see figure 5. This can twist the body, open the jaw and bend the pin.

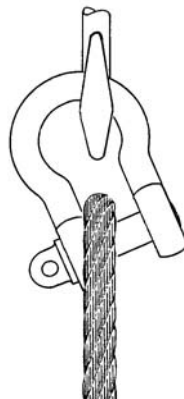

Figure 5

EXAMINATION

Shackles fall under the heading of 'lifting accessories' in modern legislation and therefore should be examined by a competent person at periods not exceeding six months. Nothing will be achieved by a load test during the examination of in-service shackles as the strength is known prior to the examination. Indeed, such a test can be damaging if the item is worn but within acceptable limits. In-service shackles should therefore be carefully visually examined. In particular the following should be checked:

- (1) Free working of the pin.
- (2) Threads. The threads, both male and female, should be fully formed with no flats or worn portions and must be full size. There should be no excessive play when the pin is screwed in by hand from either the correct or reverse side.
- (3) Holes must align. The pin hole should not be too large so as to allow a gap when the pin is in place.
- (4) The maximum permissible wear is 8% reduction in material diameter on either the pin or the body.
- (5) There should be no signs of nicks, cracks, corrosion or chemical attack.
- (6) There should be no distortion. The body should have a good shape and the pin must show no signs of bending.
- (7) The length of pin and thread length should be correct for the shackle body. In the case of bolt and nut pins, when fully tightened they should not deform the body. In the case of screwed pins the thread must not be too long so that continued tightening results in closing the jaw gap of the body or so that more than the tapered run out of the thread is exposed inside the jaw of the shackle. Neither must they be too short so that the collar or seat of the pin is held away from the body when the pin is fully tightened.
- 8) Marking should be clear and legible.

UNIT NO 1.15

EYEBOLTS

Although eyebolts are one of the most common lifting accessories they have severe limitations in usage, which are often not fully understood, and many accidents result from misuse. This is extensively covered in Section 19 of the LEEA Code of Practice for the Safe Use of Lifting Equipment, which you should read in conjunction with this unit.

Work is currently in hand to prepare an International Standard for eyebolts which will then be adopted as a Harmonised European Standard and, therefore in turn, as a British Standard. Eyebolts that comply with the current British Standard, BS 4278: 1984, will fall within the manufacturing requirements of the standard and so we can confine our considerations to these. We can note that the general matters dealt with here can also be applied to eyebolts complying with other standards. Some background information is also necessary, as many of the eyebolts found in service will be of a commercial pattern and may not be suitable for lifting applications.

BS 4278 was first issued in 1968 however it was a standard for metric threads only and assumed lower safe working loads than for the equivalent imperial threads. This assumption was based on the fact that metric sizes are generally smaller than their imperial equivalents, eg 0.5 inch = 12.5mm but 12mm is the standard metric thread size and so the older BS 529 was left in place to cover imperial threads.

This caused problems for the manufacturers of eyebolts who needed two sets of dies, one metric the other imperial, for each nominal thread size. It also meant that demand for any particular forging size was halved resulting in increased costs.

The National Physical Laboratory undertook a research programme. They found that the slightly smaller metric forgings were capable of higher loads than had originally been allowed. This resulted in the withdrawal of both BS 529 and BS 4278: 1968 with the issue of BS 4278: 1984. The material and forging sizes are the same as the earlier edition of BS 4278, but the SWLs are increased. This allows imperial threads to be machined on the metric forgings giving loads suitable as replacement for BS 529 eyebolts. Other findings of this and other research by the NPL are also important to us and we will note them as we go through the following matters.

THREADS

One of the findings made by NPL concerned the type of threads that were suitable for lifting purposes. It was found that the land area of the thread is critical to the safety of the eyebolt as it is this that carries the full load when it is engaged. Not only is the length of thread important in this respect but the width of land area is critical.

Tests showed that fine threads, ie BSF, UNF, BSP and Metric Fine series, give insufficient land area to sustain the SWL leading to possible stripping under load. No fine threads are therefore included in BS 4278 and a general recommendation is made that eyebolts with fine threads should not be used for lifting purposes. Here we should note that eyebolts are sometimes made with fine threads for non-lifting applications, but these should not be used for lifting. The standard therefore only specifies Metric Coarse, BSW and UNC threads. These must be fully formed and, in the case of in-service eyebolts, unworn with no flats on the diameter of the shank.

SHANKS AND COLLARS

Another of the NPL findings related to the stresses set up in the shank of the eyebolt when it is being fitted. This affects the machining of the thread, the collar and the method of fitting.

It was found that the torsional stresses set up in the shank of eyebolts are high when screwed in only finger tight and in small diameter threads they are excessive. BS 4278 does not therefore specify threads below 12mm or ½ inch and a general recommendation has been issued that eyebolts with smaller threads should not be used for lifting. A further recommendation is given that on no account should eyebolts be tightened greater than finger tight.

If the eyebolt is not correctly supported the shank will be in a condition that would allow it to be easily bent, or fail. Eyebolts rely on the collar for this support and therefore eyebolts without collars should not be used for lifting applications. The collar of the eyebolt is critical to the safety of the eyebolt and it must seat fully with the mating surface of the load. To ensure this is possible the thread should be relieved at the end of the shank where it joins to the collar so as to remove any taper that might have resulted from machining. The face of the collar must also be fully formed and machined square to the shank. An undercut should be machined so that, if the area around the tapped hole is raised by the thread tapping, the collar will seat freely.

TYPES OF EYEBOLT

The three designs of eyebolt specified in BS 4278 are:

- (a) Dynamo Eyebolt
- (b) Collar Eyebolt
- (c) Eyebolt with link

(a) **Dynamo Eyebolt**



Figure 1
Dynamo Eyebolt

The Dynamo Eyebolt is the most basic in design and the most limited in use, being suitable for axial lifting only. Effectively it is a ring sitting on top of the shank and has only a small collar. Although it is limited to axial loads, the eye is large enough to accept a hook of the same capacity.

Dynamo Eyebolts get their name from the historical use to which they are put, being fitted by electric motor manufacturers to the tapped hole over the balanced lifting point of the motor. Caution is needed here as often the eyebolts used for this purpose are of a commercial pattern and are unsuitable for lifting applications; they are intended to protect the threaded hole and ensure it does not become clogged with debris. Even if an eyebolt complying to BS 4278 is fitted, caution is still needed as, whilst the tapped hole is over the CofG of the motor, if couplings or other connections are made to the motor the CofG will have changed position.

Dynamo Eyebolts have a large eye, but it is not blended to the collar and is in effect a ring sitting on the small diameter collar. As a result the eye will bend if side loaded and the shank, which is given very little support by the collar, will also bend or crack. Off axis loading by even 5° imposes undue stress on the screw thread and shank. This pattern eyebolt should only be fitted in circumstances where loading is through the longitudinal axis of the eyebolt and there is no danger of the load tilting or imposing an angular loading. In all other circumstances the Collar Eyebolt or Eyebolt with Link must be used.

(b) Collar Eyebolt

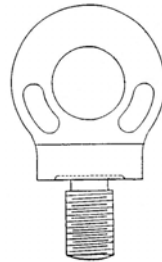

**Figure 2
Collar Eyebolt**

Collar Eyebolts were for many years considered to be the general purpose eyebolt and indeed they remain so for many thread diameters. The eye is larger than that of the Dynamo pattern and is blended to the collar in one plane. However, the eye is not large enough for direct connection to a hook and it is necessary to use a shackle for connection to other components.

NOTE: It is not uncommon to find Collar Eyebolts with a permanent link fitted to the eye to facilitate connection to other components, but such eyebolts are still subject to the same limitations for use and cannot be considered as 'Eyebolts with Link'.

When used in pairs of the same capacity, the plane of the eye of each eyebolt must not be inclined to the plane containing the axis of the two eyebolts by more than 5°. In order not to overstress the shank, this alignment may be achieved by use of shims up to a maximum of half of one thread in thickness. A reduction in the maximum load that may be lifted is necessary due to the angular loading. This is far more drastic than is required with the Eyebolt with Link, so that although in axial loading, size for size, Collar Eyebolts have a higher SWL. The capacity when subject to angular loads is far lower.

(c) Eyebolt with Link

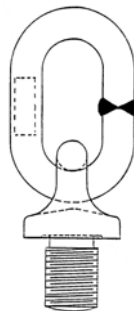

**Figure 3
Eyebolt with Link**

The Eyebolt with Link was a new design introduced by BS 4278, as a result of research by NPL. Because of this they are sometimes referred to 'new service' eyebolts. They offer considerable advantages over the other patterns of eyebolt when the loading needs to be applied at an angle to the axis and/or the plane of the eyes.

They have a small, squat, eye which is blended into the collar in all directions and a link is fitted to allow articulation and connection with other lifting components. The link is designed to accept a hook of the same capacity.

Compared size for size with Collar Eyebolts, the SWL for axial load is lower, in all other arrangements the SWLs are relatively greater than those of Collar Eyebolts when used in the same conditions. Unlike the Collar Eyebolt, the load can be applied away from the plane of the eye, as the link will articulate to align and the collar has equal strength in all directions, making correct fitting easier.

Provided that the angle of the load to the axis of the screw thread does not exceed 15°, they may be loaded in any direction to the full SWL rating. For greater angles, the load will decrease, however this reduction is less drastic than with a Collar Eyebolt. In all respects Eyebolts with Links can be considered the general purpose pattern of eyebolt, to be used for lifting whenever the loading cannot be confined to a single plane. They are however only produced in a limited range of thread diameters, so limiting their application.

MATERIAL GRADE

Eyebolts are a single piece drop forging, the shank of which is machined and threaded. Those to BS 4278 are made from higher tensile steel, which is hardened and tempered after drop forging but prior to machining. They are therefore grade M or 4.

MARKING

The marking on eyebolts is usually hard stamped directly into the material. This should always be on a low stressed part of the forging to avoid introducing stress raisers. BS 4278 requires flat areas to be raised in the forging in the bottom area of the eye for this purpose. In the case of Eyebolts with Link, the marking should be on the straight sides of the link. Should these areas be insufficient, or if the eyebolts are to a standard that does not require raised flats, further marking can be made around the periphery of the collar but it must never be around, or at, the crown or on the underside of the collar. Examples of raised areas are shown in Figures 1, 2 and 3 for the different patterns of eyebolt.

The following information should be legibly and permanently marked on the eyebolt in a manner that does not impair its mechanical strength. The symbols should be as large as possible but in any case not less than 3mm high:

- a) Quality Marking symbol 'M' enclosed in a circle.
NOTE: This should be kept remote from any thread identification to avoid confusion
- b) SWL
- c) Distinguishing Mark
NOTE: New eyebolts will usually be marked with a batch number by the manufacturer. Whilst this gives him traceability to his production, heat treatment and test records it is of little use to the user or tester and examiner. Steps must therefore be taken to ensure this number is made unique.

- d) **Thread Identification**
 NOTE: M denotes ISO metric threads, coarse series. The identification should also include the thread diameter, eg M20.
 BSW denotes BS Whitworth threads. The identification should also include the thread diameter, eg ½ BSW
 UNC to denote unified coarse threads. The identification should also include the thread diameter, eg ¾ UNC. An older designation '000' was used to indicate the Unified Thread form.

STRESS IN EYEBOLTS

The eye of an eyebolt acts very much as a ring (See unit 1.11). The position of maximum tensile stress in the eye will be either on the outside or inside, depending on the proportions of the inside diameter to the diameter of the material, see Figure 4.

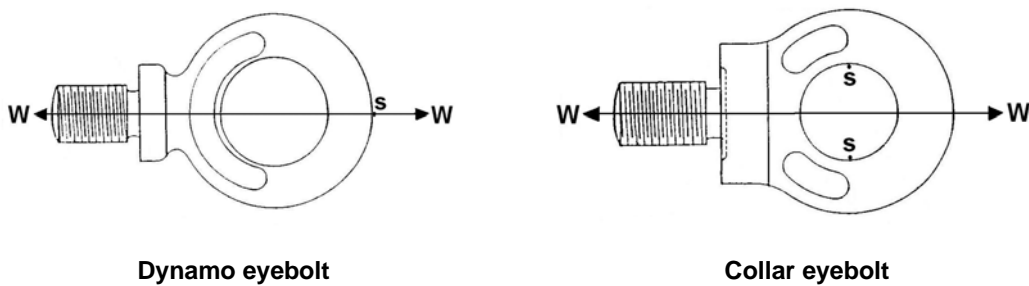

Figure 4
Position of Maximum Stress in Eyebolts

In correct use, the shank is in pure tension, which will be below the maximum stress value in the eye, however, the shank and thread must have a smooth finish, with a radius at the bottom of the thread, to prevent stress raisers that could cause premature failure due to the notch effect.

MANUFACTURER'S TESTS

Hardness Test

BS 4278 requires the manufacturer to make a Brinell hardness test, but the requirement is badly written as it is unclear the sampling rate to which this applies. It is usual to sample three items from each heat treatment batch, one from the top, middle and bottom and it must be assumed that this is the minimum.

Proof Loading

BS 4278 calls for every eyebolt to be proof load tested to at least twice the WLL. It further requires that a copy of the test information is passed on to the user giving the distinguishing mark, thread form and size, the load applied and the SWL.

THE USE OF EYEBOLTS

Lack of understanding of the nature of eyebolts leads to misuse and this in turn causes damage and ultimately failure. So before we consider the matters to be taken into account during an examination we will look at the use of eyebolts and the defects and damage that can be introduced by misuse. Full details of the safe use of eyebolts are given in Section 19 of the LEEA Code of Practice for the Safe Use of Lifting Equipment, which you should also study.

All eyebolts for lifting purposes should have collars. The face of the collar must be smooth, flat

and at right angles to the axis of the thread. The surface the collar beds onto must make good contact all over, without undue tightening. When tightened down by finger pressure only, it should be impossible to insert a feeler gauge of 0.04mm at any point between the collar and its seating. If the eyebolt is not seated there is a real risk that the shank will become bent.

Plant and equipment may have a variety of plain and tapped holes into which eyebolts can be inserted. However, these holes may not have been intended for lifting purposes and must be checked by someone who is competent to do so before use. The tapped hole into which the eyebolt is to be fitted should be of sufficient depth to accept the full length of the shank, ideally it should be countersunk to allow the eyebolt to be tightened to meet the necessary requirements. If this condition is not met the shank may become bent.

Eyebolts must never be tightened other than by finger pressure and no attempt must be made to 'nip' them tight. They must be correctly aligned for the type of lift to be made and must not be re-machined or modified to meet this condition. Shims and washers are necessary to ensure these conditions are met. The use of mechanical aids (eg tommy bars) can result in over-tightening causing 'necking' of the shank above the thread, which will lead to sudden failure.

It is also essential that eyebolts should be screwed only into tapped holes with which they are compatible. Mismatch between threads can result in a loss of strength of up to 50%. The possibility of mismatch is very apparent considering the number of thread forms available, (eg BSW, BSF, UNC, UNF and Metric). Not only can metric threads be mismatched with the others, but also each size is capable of mismatch within its own range because all sizes will engage with the next size up with the exception only of 14mm.

Commercial pattern eyebolts with tapered or rolled threads and eyebolts that do not have relieved threads must not be used for lifting purposes as they will not seat properly and will become bent. Eyebolts with thread sizes below 12mm (½") should not be used for lifting purposes as they will be over strained during the fitting operation.

If a single eyebolt is to be used for vertical lifting where the load is liable to revolve or twist, the lifting appliance must be fitted with a swivel type hook to prevent the eyebolt unscrewing. Similarly, where eyebolts are fitted in clearance holes with back nuts some form of restraining device must be fitted to prevent the nut unscrewing.

Eyebolts should not be used on an endless sling and should not have a sling reeved through them as this will impose stresses in the wrong plane and lead to bending.

EXAMINATION

Eyebolts fall under the heading of 'lifting accessories' in modern legislation and therefore should be examined by a competent person at periods not exceeding six months. Nothing will be achieved by a load test during the examination of in-service eyebolts as the strength is known prior to the examination. Indeed, such a test can be damaging if the item is worn but within acceptable limits. In-service eyebolts should therefore be carefully visually examined. In particular the following should be checked:

- (1) Threads should be fully formed with no wear, flat areas or signs of cross-threading etc.
- (2) Shank should be correctly aligned, it should be central to the collar and the axis at 90° to the collar face. Particular care must be given to the examination of the junction of the

- shank and collar; there must be no signs of necking or cracking.
- (3) The shank must not show any signs of bending and under no circumstances should any attempt be made to straighten bent shanks.
 - (4) The face of the collar should be even and undercut around the shank so that it will seat evenly on its mating surface. Any burrs should be carefully removed with a fine file.
 - (5) The eye should show no signs of bending or distortion. The maximum permissible wear is an 8% reduction in material diameter.
 - (6) The general condition of the forging should show no signs of corrosion, chemical attack, nicks, cuts or gouges.
 - (7) The marking should be clear, but not too deep and this will act as a stress riser.

UNIT NO 1.16

REVISION ASSIGNMENT

This is the second revision Assignment of Course 1, which again is laid out as a multi-choice paper in the same way as the question paper for the Part 1 Entry examination. The intention is that you gain experience in answering this type of question paper quickly and correctly, so gaining the necessary examination technique that is called for with this type of examination.

In the examination you will be allowed 1 hour to answer 100 questions and so this paper, of fifty questions, should not take longer than 30 minutes to complete.

In order for you to prepare for the examinations, it is suggested that you approach this in the way you would if it were the actual exam. Do not refer to the earlier units or other reference material, but answer the questions from the knowledge you have gained so far. The paper only recalls matters that have been covered in the course so far. Remember that the marks you receive are there to help you identify the areas and matters you need to revise. Cheating to gain better marks will only mislead you into believing you are doing better than you really are and there are no prizes for getting high marks.

The pass mark for the examination is 65%. If your mark for this Assignment is less than 70% you need to do some determined revision. In any event you should organise a short period for revision on a regular basis. Use the marks you obtain here as your guide to the matters you need to revise.

ANSWER ALL FIFTY QUESTIONS by ticking the box opposite to the answer of your choice in pencil. Should you change your mind, erase the first tick and place a new tick in the box corresponding to your new answer. If you find you need to make small calculations, notes or other jottings to help you, by all means do this on the side of the paper. The tutor will ignore these, as will the examiner in the actual examination but please ensure any such notes are kept well away from the answer boxes so as to avoid confusion.

It is suggested that you read through the paper ticking only the answers of which you are certain. Once you have worked through the paper in this way return to the beginning and answer those questions you initially did not attempt.

Once the marked paper is returned to you, look through it noting those questions you got wrong and use them as a basis for your revision programme. Remember last minute revision seldom helps, in fact it often hinders, but a subject well learnt and constantly revised is never forgotten. To this end little and often is of far more benefit than long sessions.

UNIT NO. 1.17

TEXTILE SLINGS

Although flat woven webbing slings, roundslings and fibre rope slings are produced by very different methods and offer very different characteristics for the use, they are very closely related and have many common features. We are therefore able to bring them together under the family heading of textile slings for our studies.

In previous units we considered components for slings, some details of which you will be expected to recall in your studies here.

Textile slings are covered by three parts of BS EN 1492. Part 1 covers flat woven webbing slings, Part 2 covers roundslings and Part 4 covers fibre rope slings. There is no Part 3 to this standard, the reasons for which we will consider later in this unit.

Very few, if any, fibre rope slings are used nowadays in the UK. They are still used to some degree within Europe. This is due to their bulk and the fact that reliable flat woven webbing slings and roundslings are readily available, easier to handle and are far more convenient to store.

FIBRES USED FOR TEXTILE SLINGS

Although their finished form is very different, the family of textile slings are produced from the same range of man-made fibres. Additionally, fibre rope slings are also produced from a limited range of natural fibres.

Textile slings are manufactured from three man-made fibres; Polyamide (nylon), Polyester and Polypropylene. Additionally, fibre rope slings may also be produced from Manila, Sisal and Hemp, which are natural fibres.

Roundslings made from a fourth man-made fibre, Kevlar, may also be found in service. This material has been excluded from BS EN 1492 as too little is known about its behaviour and there is a history of sudden and unexplained failures in service. There is anecdotal evidence of new slings, being correctly used, severing on the first lift. The European standards committee therefore felt, until contrary evidence can be gathered, this material was not suitable for the manufacture of lifting slings.

Although the various fibres have many common features, they behave differently to chemical contact, temperature and environment, so we will begin by looking at their characteristics.

Temperature

Polypropylene, manila, sisal and hemp fibres are suitable for use in the temperature range -40°C to 80°C. Polyester and polyamide are suitable for use in the range -40°C to 100°C. If man-made fibres are used at higher temperature than those given they will, at first soften, begin to melt and fuse together. As the temperature rises they will char, becoming brittle and burn. Natural fibres will simply become brittle, char and burn.

Chemical Resistance

Natural fibres have no resistance to chemical attack; however the various man-made fibres have selective resistance to chemicals as follows:

Polyamide is immune to the effects of alkalis, but is attacked by acids
Polyester is resistant to acids but damaged by alkalis
Polypropylene is little affected by acids or alkalis but is damaged by solvents, tars, paints etc.

Ultra-violet Radiation

All textile fibres become brittle as the result of exposure to sunlight or other sources of ultra-violet radiation. This is known as solar degradation. Its effect is more pronounced in man-made fibres, but it is hard to detect until at an advanced stage. Then, very quickly, they will become brittle, turn to powder and crumble away.

During the manufacturing stage man-made fibres, intended for use in sling manufacture, are subject to a process known as stabilising. Whilst this does not prevent solar degradation it does slow down the rate of this effect.

Wetting

Natural fibres do not behave well when wet with a general, but small, loss of strength. They absorb the moisture and this increases their weight, making them more difficult to handle. Further, wetting will speed the natural rotting process. Unless dried and handled carefully they will be attacked by Mildew, which will grow on the fibres and live on the cellulose, so weakening the fibre. This also occurs if natural fibres are stored in damp, musty, conditions and this greatly shortens their life.

Man-made fibres do not suffer this way, as Mildew will not grow on them. If any is found, it is growing on surface contamination which will have no effect on the fibres, and can usually be washed off with clean water.

However water does affect man-made fibres in other ways:

- Polyamide loses about 10% of its strength when wet
- Polyester is unaffected
- Polypropylene shows an increase in strength when wet and it will float.

Elongation

Natural fibres have little elongation under load, however, because of the way a rope is made, a fibre rope sling will stretch when put under load as the fibres and strands bed down in the rope.

Man-made fibres elongate considerably more. Polyamide is highly elastic and stretches as much as 40% under load; Polyester on the other hand only stretches by approximately 5%; whilst Polypropylene stretches by varying amounts, usually less than Polyamide but more than Polyester. This calls for careful selection of slings, particularly where headroom is limited, where it is possible for the sling to stretch to such an extent that the load cannot be lifted.

As well as being elastic, man-made fibres also have plasticity and some permanent elongation occurs every time that they come under load. Whilst this permanent elongation is small, a man-made fibre sling actually 'grows' in length every time it is used.

Material Identification

The various man-made fibres visually appear much the same, making their recognition extremely difficult. An international system of colour coded labels, which carry the information necessary to be marked on a sling (see marking), has therefore been adopted in standards as follows:

- Polyamide – Green label
- Polyester – Blue label
- Polypropylene – Brown label
- Natural fibres – White label

Although the natural fibres can be recognised visually when new, when they have been in use and become soiled it is difficult to tell one from another. It is considered that their use for slings is now rare and so the sling standards ask only for the material to be stated on the label, see marking.

FLAT WOVEN WEBBING SLINGS AND ROUND SLINGS

Flat woven webbing slings, sometimes referred to as belt slings, are soft to handle, pliable longitudinally whilst offering rigidity across their width. These qualities make them ideal for handling loads that require some support when being lifted as the load is spread across their full width, unlike ropes and chains that tend to have point contact with the load. They are less robust and more easily damaged than the equivalent capacity wire rope and chain slings.

Flat woven webbing slings are manufactured to BS EN 1492-1, Textile slings – Safety – Flat woven webbing slings, made of man-made fibres, for general purpose use. This standard covers slings made from Polyamide, Polyester and Polypropylene. In practice the vast majority are made from Polyester and most testers and examiners are unlikely to encounter webbing slings made of either of the other two.

Round slings are soft to handle and are completely pliable. This makes them ideal for lifting delicate loads or loads with polished surfaces. They are less robust and more easily damaged than the equivalent capacity wire rope and chain slings.

Round slings are manufactured to BS EN 1492-2, Textile slings – Safety – Round slings, made of man-made fibres, for general purpose use. Like the webbing sling standard, this standard covers slings made from Polyamide, Polyester and Polypropylene. Again, the vast majority of slings are made from Polyester and it is unlikely the vast majority of students will ever see them made from other materials.

Flat Woven Webbing Sling Construction

Flat woven webbing slings may be made from a single thickness of suitable webbing (simplex) or two layers of webbing (duplex). Unlike steel products, the initial tensile strength of the webbing is affected by several factors and these are outside of the sling manufacturers' control. BS EN 1492-1 therefore refers to the 'sewn webbing component' as being the basis for calculating the WLL.

The standard also requires that all of the material and stitching yarn, and the eye reinforcement if it is textile, are of the same man-made fibre due to the varying properties of the different fibres.

The webbing is cut, using a hot knife, so that the cut ends are sealed against fraying. Eyes are then formed at each end and are sewn. Each of the manufacturers have their own stitching patterns and this is relatively unimportant, the standard making only two important requirements: 1) the stitching must be made on a lock stitch machine, so that a cut thread cannot be unpicked or run and 2) the stitching must not over run a cut end or the selvage of the webbing.

Endless webbing slings can also be manufactured to the standard, but they are extremely rare in service now and have largely been replaced by the roundsling.

The standard requires that soft eyes are fitted with reinforcement to protect the inner surface from damage. Although some slings will be found in service with sewn in end fittings these are less common now and it will be found that the vast majority of slings have soft eyes. Where fittings are made into eyes as part of the sling, it is a requirement of the standard that the fittings must conform to the relevant part of BS EN 1677.

Figure 1 shows examples of the different ways of making eyes, the eye reinforcement is omitted for clarity. Figure 2 shows the various types of flat woven webbing sling covered by BS EN 1492-1.

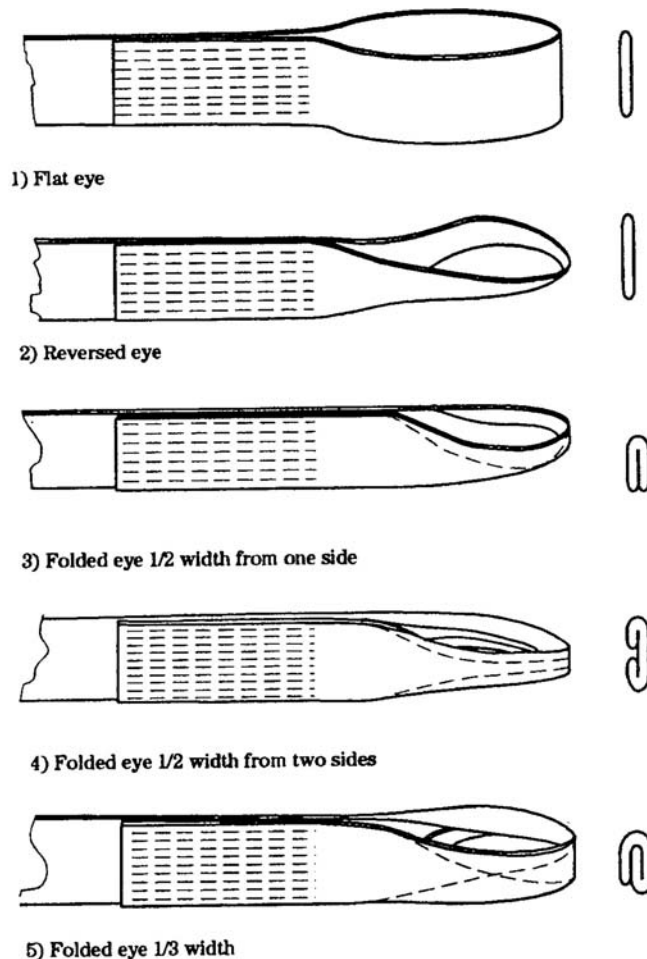

Figure 1 Eye Formations



Form	A – endless	B - single sling with reinforced eyes	C - single sling with fittings Cr - single leg with reeveable fittings
Load bearing webbing parts			 C Cr
Single load bearing part		Single layer sling with reinforced eyes B1 	Single layer sling with fittings C1 Cr1 
Two load bearing parts	Single layer sling A2 	Two layer sling with reinforced eyes B2 	Two layer sling with fittings C2 Cr2 
Four load bearing parts	Two layer sling A4 		

Figure 2
Types of Flat Woven Webbing Slings

Roundsling Construction

Roundslings are made with an inner core, produced in the form of a hank of fibres, which is the load bearing element. The core is housed in a loose outer cover.

To make the core, one or more yarns are wound around a pair of mandrels set apart at the required EWL. There must be a minimum of eleven turns of yarn in the core and these must be uniformly wound. A simple taped joint is made at the finish. If it is necessary to join the yarns there must be at least four turns of yarn separating the joints, see Figure 3.

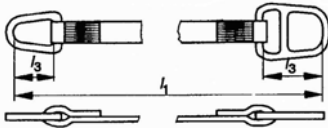
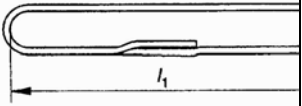
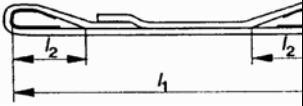
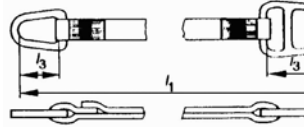
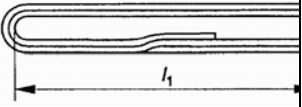
The core is then covered with a protective sleeve, which is longer than the core, so that when the sling is in use only the core comes under load. The core, sleeve and any stitching must all be of the same man-made fibre due to the varying properties of the different fibres.

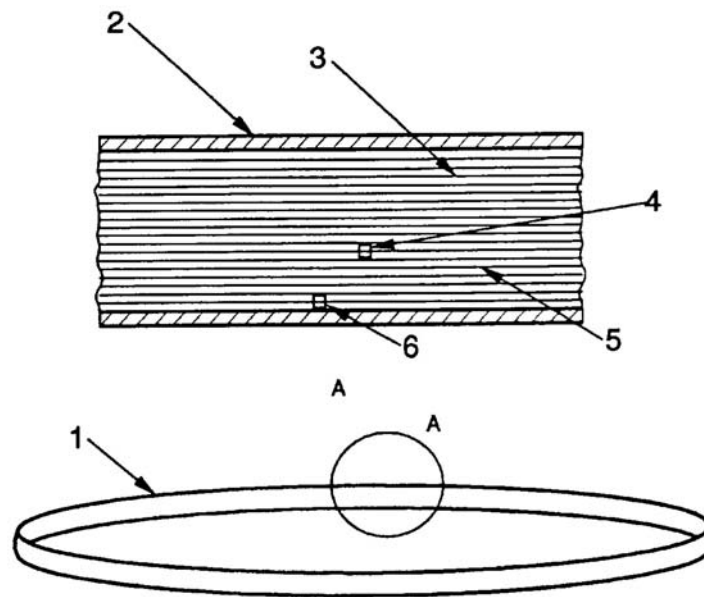

- 1 - Roundsling
- 2 - Cover
- 3 - Core yarns
- 4 - Additional join
- 5 - Minimum of four turns of yarn
- 6 - Join forming endless hank

Figure 3
Principle of Core Construction

Manufacturer's Verification

Due to the variables associated with man-made fibre materials and with webbing sling and roundsling manufacture, it is not possible to apply a simple factor of safety to arrive at the WLL. Both BS EN 1492-1 and BS EN 1492-2 therefore require the manufacturer to carry out certain type tests. These are intended to prove both the design, workmanship and materials of the slings prior to production commencing as, unlike a steel item, the actual tensile strength is not known until a sample sling is tested.

In the case of webbing slings, these must be carried out for every batch of webbing and each batch of stitching yarn used. Similarly, if there is a change of stitching pattern or any other significant changes, other than length, the manufacturer must again carry out these tests. In the case of roundslings it is only necessary to carry out further type tests if there is a change of material. One of the tests is a load test to confirm that a minimum FOS has been achieved.

Both standards also require the manufacturer to perform manufacturing tests on selective samples, at a specified sample rate, from every batch of slings they produce. This is to ensure that no unexpected changes have taken place since the type tests were carried out. A sample sling is placed in a test machine and a force equivalent to seven times the WLL is applied. The sling must sustain this force without failure. If the sling fails a further three samples must be tested and if one or more of these fail the batch must be rejected. This is the same test as is made as part of the type testing.

As some of the possible defects in textile slings can only be detected by touch, the standards calls for all slings to be both visually and manually examined on completion of manufacture.

Colour Coding

Flat woven webbing slings and roundslings are colour coded to signify the WLL of the 'sewn webbing component' or basic roundsling in straight pull. This must not be confused with the WLL of the completed sling assembly, which may be different. The marking information must always be read to establish the WLL of the sling assembly.

Marking

The required marking must be on the appropriate coloured label, signifying the material from which the sling is made, see material identification. The marking must give at least the following information; the identification mark, the WLL in straight lift, the material from which the sling is made, the grade of any fittings, the length, the manufacturer's name and any marking required by legislation, ie the CE mark.

In the case of webbing slings this label has to be sewn into the eye or joining stitching of webbing slings, see Figure 4. In the case of roundslings the label may be sewn into the joint in the cover sleeve or be so that it slides loosely over the cover sleeve, see Figure 5.

You will have noted that in addition to the sling and label being colour coded it must also be marked with the WLL and the material. The reason for duplicating this information is simple, a survey found that a large proportion of the working population of Europe are found to be colour blind.



Figure 4
Labelling Options for Flat Woven Webbing Slings

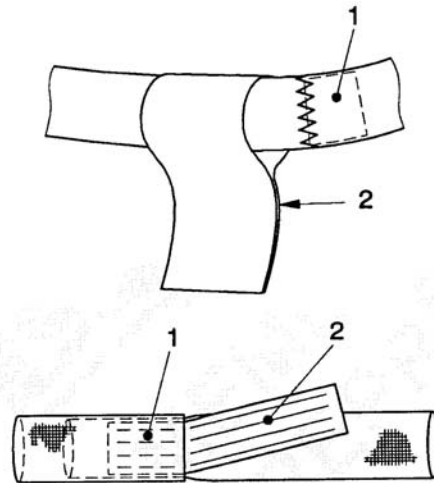

Figure 5
Labelling Options for Roundslings

Cautionary Note

A type of webbing sling, known as a one trip or disposable sling, was at one time covered by BS 3481. Many slings to this standard were produced from thin webbing, similar to a car seat belt, as the standard only required a 5:1 FOS. They were intended to be pre-slung on a load at the point of despatch for loading purposes and remain on the load until arrival at its final destination, to be used for off loading and then be destroyed.

The European Standards Committee was asked to consider these when writing the EN 1492 series of textile sling standards. The resulting standard would have been Part 3. After much debate, the committee concluded that it could not justify a standard with a lower FOS as the hazards would be far greater than for general purpose slings. Indeed the associated risks are such that the committee concluded that a far higher FOS was necessary. No standard was written and the mandate for this was withdrawn. The British Standard was also withdrawn. Nonetheless, many slings of this type are still produced worldwide, and used to pre-sling a variety of loads which get shipped all over the world, usually without supporting examination reports. Occasionally, they find their way into general use. Should the tester and examiner ever find such slings they should ensure that they are immediately removed from service.

FIBRE ROPE SLINGS

Fibre rope slings are no doubt the oldest form of sling, their origins are recorded in the earliest history of lifting equipment. Although their popularity has fallen off greatly in modern times in favour of more convenient forms of sling, eg webbing and roundslings, a few remain in service. Whilst most testers and examiners may never encounter them, many will.

Fibre rope slings are manufactured to BS EN 1492-4 – Textile slings – Safety – Lifting slings for general service made from natural and man-made fibre ropes. The standard covers slings made from ropes of Polyamide, Polyester, Polypropylene, manila, sisal and hemp. The slings are produced from cut lengths of 3, 4 or 8 strand rope which are then

hand spliced. They are bulky to handle and natural fibres, in particular, are rough to the touch. Rope slings are less pliable than other types of textile sling and, unlike other textile slings, they present a hard point contact with the load although this is less severe than with chain or wire rope.

Rope Construction

Fibre ropes are spun in much the same way as wire ropes. A rope is made by spinning the fibre yarns together to form a tight strand and then spinning a number of strands, usually 3 or 4, to form a rope. In the case of man-made fibres another method is to make smaller diameter strands and then plait them to form a rope. Any one of these three constructions of rope can be used to make slings, although it will be found that 3 strand is the most common.

The more strands in the rope, the more flexible the rope will be. However rope is far less pliable than webbing or roundslings. Figure 6 shows a three strand and an eight strand plaited ropes.



Figure 6
Three Strand and Eight Strand Plaited Ropes

Sling Construction

Single leg, multi-leg or endless fibre rope slings can be produced. They are made by hand splicing eyes at each end of a piece of rope or by splicing one cut end of a rope to the other end forming an endless loop. In the case of multi-leg slings, the eye one end of each sling leg is made through a master-link. Where this is done the use of thimbles is advised to protect the eyes.

Eyes are produced by bending the rope to form a loop. The strands in the end of the rope are separated and then tucked back into the standing part of the rope against the lay to form the eye, in a similar way as with wire rope. This is done in such a way that they lock and do not slip when a load is applied. There are differences in the splicing requirements, depending on the type of rope used due to differing coefficients of friction.

In the case of 8 stranded ropes, splices must be made fully in accordance with the rope manufacturer's instruction, which must be sought and followed. For 3 or 4 stranded ropes the standard makes the following requirements for splicing:

- 1) Polyamide ropes, Polyester multifilament ropes and Polypropylene monofilament ropes; either five full tucks or four full tucks with all of the yarn followed by a further tuck with at least 50% of the yarn and a final tuck of not less than 25% of the yarn.

- 2) Polypropylene fibrillated film and staple ropes and natural fibre ropes; not less than four full tucks.

In the case of endless slings the splicing requirements above must be made each side of the marrying point.

It is important that the splicing tucks are made against the lay of the rope. The 'Liverpool splice', where the tucks are with the lay, is prohibited because, if the rope is allowed to spin or turn under load, the splice will unravel itself. Figure 7 shows a spliced eye with thimble.

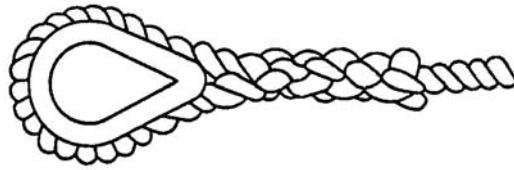

Figure 7
Spliced Eye with Thimble

Manufacturer's Verification

The splices produced by each person will vary in efficiency to some degree. Therefore BS EN 1492-4 requires the manufacturer's type tests to be made for each splicer as well as for each size and type of rope and each splicing method used. These tests are made on specially produced test pieces, which must sustain a force equivalent to 7 times the WLL. In the case of endless slings the force is equivalent to 5 times the WLL.

Similar tests are made periodically from slings selected from the manufacturing batch to ensure no unexpected changes have taken place. If the specimen fails to sustain less than 90% of this force a further three samples must be selected for test. If any one of these fails the test the batch must be rejected.

All slings produced must be visually examined.

Marking

The required marking must be on an appropriately coloured label, signifying the material from which the sling is made, see material identification. The marking must give at least the following information: the identification mark, the WLL, the material of the rope, the size of the rope and the sling length, the grade of any fittings, the manufacturer's name and any marking required by legislation, ie the CE mark.

One of the best ways of attaching the label to rope slings is to place them around the rope and cover them with a heat shrink clear plastic sleeve. This requires the sleeve to be passed over the rope prior to splicing.

RATING OF TEXTILE SLINGS

Single leg and endless, including roundslings, are rated and marked in straight pull. Multi-leg slings are rated by the uniform load method. Each of the three parts of BS EN 1492 contains tables of the working load limits for each type of material and sling configuration.

MANUFACTURER'S DOCUMENTATION

In the case of a new sling, the manufacturer is required by the European Machinery Directive (Supply of Machinery {Safety} Regulations in the UK) to issue an EC Declaration of Conformity. The various parts of BS EN 1492 call for a 'manufacturer's certificate'. In fact there is little difference between these two documents and they are easily combined into one. So as not to confuse the user with a myriad of different documents, and for other administrative reasons, many companies prefer to retain these documents in their 'technical file' and issue reports of thorough examination in accordance with LOLER.

In either event, it is essential that the sling manufacturer has complete traceability for the yarn, webbing, rope, stitching thread and components used. The items used in the sling assembly should be listed as part of the sling description. The report should also show the WLL. For multi-leg slings this should be expressed at 0-45° to the vertical and, if additionally required by the user, at 45°-60° to the vertical.

THE USE OF TEXTILE SLINGS

Before we consider the matters to be taken into account during the examination we will take a look at the use of textile slings and the damage and defects that can occur due to misuse. Full details of the safe use are given in Sections 15, 16 and 17 of the LEEA Code of Practice for the Safe Use of Lifting Equipment, which you should also study.

Slings must not be used to lift loads greater than the marked SWL, taking account of the slinging mode and resultant loads that may be imposed. Unintentional overloading where these matters have not been taken into account is one of the more common causes of damage to slings.

Slings must be compatible with the load, lifting appliance and any accessories in the lifting arrangement, both in capacity and physical size. The angle formed in the eye of webbing slings should not exceed 20° in use, or 30° in the case of rope slings. The seating on which a roundsling sits should be of adequate diameter and width to allow the sling to adopt its natural flattened position under load. Failure to ensure these measures are taken will result in pulled stitching of webbing sling eyes, damage to the strands at the base of soft eyes in ropes and bunching of the core of roundslings causing cutting of the cover and/or damage to the core.

Slings must not be bunched on hooks and fitting with which they mate. This may lead to cutting, tears and similar damage.

Due to the different stretch and recovery rates of the various fibres, and that the elongation of a sling is proportional to its length, only slings of the same type and material should be used in combination. Account of these factors must also be made if sling legs of different lengths are used in the arrangement. If this is not done the load may

become unbalanced resulting in some of the legs being overloaded and, at worst, the load being taken on a single leg leading to its failure.

Slings should be positioned correctly to avoid movement of the sling, either against itself or over other fittings and attachments. For choke hitch slings should be positioned in the natural angle of 120° and not allowed to slide to this position as the load is taken. Movement of the sling will result in heat being generated due to friction which can be sufficient to cause fusion of fibres and similar heat damage.

Slings should be positioned over generous radii so as to evenly distribute the load. When placing the sling around corners suitable packing must be used. Failure to adopt these measures will result in abrasion and/or cutting, which can be sudden and severe.

Avoid shock loading slings. This could result in permanent elongation or, at worst, failure of the sling.

When using slings in chemical environments, ensure the material of the sling is suitable. Failure to do so will result in damage to the fibres and the sling will have to be removed from service.

Avoid undue exposure to sunlight or other sources of ultra-violet radiation. Prolonged exposure will result in a breakdown of the fibres.

Avoid heat, which will soften and burn the fibres. Textile slings are commonly used in welding shops so as to isolate the work piece from the hoisting mechanism, care must be taken to avoid weld splatter, which will embed in the sling and damage and sever the fibres.

EXAMINING TEXTILE SLINGS

Textile slings fall under the heading of 'lifting accessories' in modern legislation and therefore should be examined by a competent person at periods not exceeding six months. Nothing will be achieved by a load test of textile slings, either as a proving test or during an examination. Such a test will not reveal anything not already known and could damage the sling beyond further use.

During the examination of textile slings the following should be checked:

- 1) Surface chaffing. In use some chaffing is unavoidable. If this is confined to the surface fibres, it has no serious effect, however, if severe it may lead to cuts and so should be carefully examined.
- 2) Local abrasion, as opposed to general wear, and cuts will result in serious loss of strength and lead to failure.
- 3) Chemical attack. Whilst man-made fibres have good resistance to selective chemicals, attack by other chemicals result in weakening and softening of the material. This is indicated by flaking of the surface fibres, which can be plucked or rubbed off. In early stages the material may feel sticky to the touch.
- 4) Heat and friction damage. The surface fibres take on a glazed appearance in the early stages. In extreme cases the fibres fuse, show signs of melting, char and burn.

- 5) Weld splatter damage. This will cause local burning and will embed in the sling causing internal abrasion and sever the yarns.
- 6) In the case of webbing slings, damaged stitching. If the stitches pull and run or become very loose this must be treated very seriously. Similarly if the webbing becomes loose so that the weft can be moved or split with the fingers the sling should be removed from service.
- 7) In the case of roundslings, any damage to the outer sleeve is indicative of internal damage to the core. As the sleeve is longer than the core, the core can move round within the sleeve and so present an apparently uncut core at areas where the sleeve is cut. However, the core may well be cut in a position where it cannot be seen.
- 8) In the case of webbing slings and fibre rope slings. Damaged eyes, collapsed thimbles or damaged terminal fittings.
- 9) Soiling can pick up grit and dirt which act as an abrasive and can lead to rapid wear, both externally and internally.
- 10) Missing or illegible marking.

UNIT 1.18

MECHANICS - SIMPLE MACHINES

In this unit we will look at a branch of engineering science known as mechanics. We will see how this affects the tester and examiner in his day-to-day duties by considering some simple examples. This is an involved subject but at this stage it is not necessary to have a deep understanding, therefore some of the explanations have been greatly simplified. Students who have previously studied this matter will be familiar with the principles outlined in this unit, others may wish to study these matters in more depth and are advised to obtain any good engineering science textbook.

MACHINES

In engineering science, a machine can be defined as 'a piece of equipment for overcoming a force applied at one point by means of a force applied at another point'. The simplest example is the lever, for even though it has no moving parts it meets the description. The single sheave pulley block, which in its basic form, serves only to reverse the direction of the force is the simplest moving machine.

Before we can progress we need to make some assumptions and define some of the terms used.

Although not strictly true, we will consider **Weight** and **Force** to be equal and expressed in the same units. In a lifting machine a small weight or force is used to lift a larger weight or force. We call the force required to do the lifting, the **Effort**, and the force being lifted, the **Load**.

If we consider the single pulley and ignore **Friction**, then if the load and effort are equal they will be in balance and remain stationary, that is to say be in **Equilibrium**. Any increase in the effort will move the load. In more complicated machines, eg a chain block, the effort required to move the load is usually much smaller than the load. Their relationship is known as the **Mechanical Advantage**. This is called the Force Ratio in some publications as it is indeed a ratio of the forces. We will however only use the term Mechanical Advantage in this unit.

Again if we consider the single pulley, the distance moved by the load will be the same as that travelled by the effort. With a chain block the effort has to move a much greater distance than that travelled by the load. This relationship of movement is known as the **Velocity Ratio**. This is known as the Movement Ratio in some publications. Although this might at first seem more appropriate, since it is a ratio of the movements, as both take place in the same time period it is also true that it is a ratio of velocities, we will therefore only use the term Velocity Ratio.

We measure the input and output as **Work Done**. The relationship between the **Work Input** and **Work Output** is a measure of the **Lost (or Wasted) Work**. Their relationship is known as the **Efficiency**. We will see later that we can express the work done in terms of the Mechanical Advantage and the Velocity Ratio and can therefore also express their relationship as Efficiency.

THE LEVER/MOMENTS OF FORCE

In our opening comments we said that a **Lever** can be considered as the most basic of machines, so let us start by looking briefly at some examples of Levers. There are many examples of the Lever in our every day life, some are obvious others not so obvious, eg a spanner is an obvious example but a less obvious example is a jib crane.

When a force is applied to a Lever it gives it a turning effect, which is known as the **Moment of Force** or **Turning Moment**.

The Moment of Force = Force x shortest distance to the line of action of the force

Let us then consider the spanner shown in Figure 1.

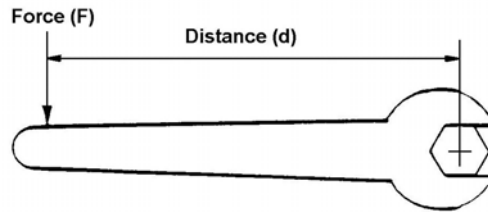

Figure 1

When we apply a force (**F**) on the spanner at a distance (**d**) from the centre of the bolt the turning moment on the bolt is **F x d**

Example 1

Calculate the Turning Moment on a bolt when a 0.6m long spanner has a force of 80N applied to its end.

Known Information : Force (F) = 80N

Distance (d) = 0.6m

As turning moment = F x d

So turning moment = 80 x 0.6

Therefore Turning Moment = 48 Nm

This turning moment is called **Torque**.

Torque is important to the examiner and tester. For example the nuts of wire rope grips must be set to the correct Torque, as must the foundation bolts of crane structures. These are set using a Torque Wrench, which allows the nuts to be tightened to a known Torque. In the course of our duties it is often necessary to check that nuts have been correctly tightened to the required Torque.

If we then consider a box spanner represented by Figure 2.

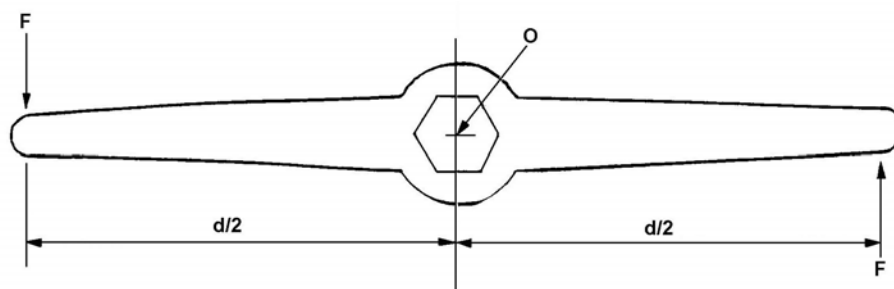

Figure 2

This type of Turning Moment is known as a **Couple**, where two equal and parallel forces are applied symmetrically about a point. Here they act about a bolt centre (**O**). The forces here are acting anti-clockwise and would cause the bolt to turn. If however the forces were applied in opposite directions the lever would remain stationary, that is in Equilibrium, as the Anti-clockwise Moment about point O = Clockwise Moment about point O. Point 'O' is the **Pivot Point** or **Fulcrum** about which the forces act.

Consider the crowbar shown in Figure 3. **E** is the downward effort, **L** is the downward force of the load, **O** is the Fulcrum, **S** is the distance of the effort from the Fulcrum and **d** is the distance of the point of contact through which the load acts from the Fulcrum.

The load will be balanced (in Equilibrium) if:

$$L \times d = E \times S$$

(Anti-clockwise moment) = (Clockwise moment)

If $L \times d$ is greater than $E \times S$ the load will be lowered and if $E \times S$ is greater than $L \times d$ the load will be raised.

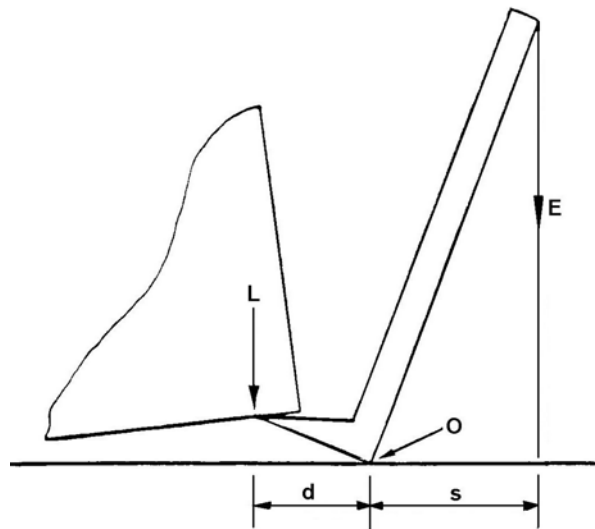

Figure 3

Example 2

Calculate the value of the force P necessary to keep the lever shown in Figure 4 in equilibrium.

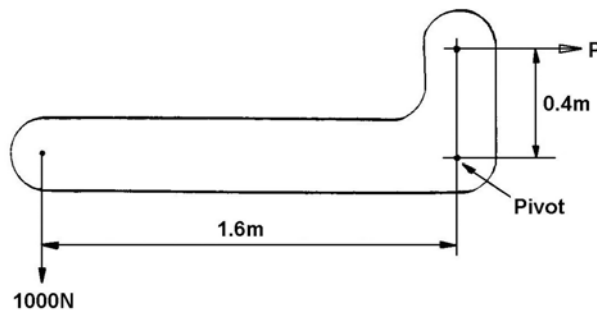

Figure 4

Taking moments about the pivot

$$CWM = ACWM \quad P \times 0.4 = 1000 \times 1.6 \quad P = \frac{1600}{0.4} = 4000 \text{ N},$$

$$\underline{\text{Hence } P = 4000 \text{ N}}$$

MECHANICAL ADVANTAGE

Now let us look at more complicated machines. In our opening comments we saw that the relationship of **Load (W)** to **Effort (P)** is known as the **Mechanical Advantage (MA)**.

$$\text{Hence Mechanical Advantage} = \frac{\text{Load}}{\text{Effort}} \quad \text{or } MA = \frac{W}{P}$$

Since the units of load and effort are the same MA has no units and is a simple ratio.

If we know the load to be lifted and the effort applied to a machine we can calculate the Mechanical Advantage, as shown in Example 3.

Example 3

If a machine can lift 100kg with the application of an effort of 10kg what is the Mechanical Advantage?

Known information: Load (W) = 100kg

Effort (P) = 10kg

$$\text{If } MA = \frac{W}{P} \quad \text{Then } MA = \frac{100}{10}$$

Hence MA = 10

So we can see that if we know the Mechanical Advantage and the force available we can calculate the load the machine is able to lift, as shown in Example 4.

Example 4

A machine has a Mechanical Advantage of 7. How much load can it lift if a force of 100kg is applied?

Known Information: MA = 7

Effort (P) = 100kg

$$\text{If } MA = \frac{W}{P} \quad \text{Then } W = MA \times P \quad \text{So, } W = 7 \times 100$$

Hence Load which can be lifted = 700kg

It therefore follows that we can also calculate the effort needed if we know the MA and load in any situation. This is useful to us when assessing the suitability of a machine for a given duty, considering operator fatigue with manually operated machines and similar considerations.

VELOCITY RATIO

The machine is then a marvellous thing for, as we have seen, we can move very large forces by applying only small ones. Unfortunately, as we all know, you never get something for nothing and in order to move the load a short distance it is necessary for the effort to travel a greater distance. The relationship between these movements is called the **Velocity Ratio (VR)**.

$$\text{Hence } VR = \frac{\text{Distance moved by effort}}{\text{Distance moved by load}}$$

As the units of distance are the same, VR has no units and is a ratio.

If we know the distance moved by both the load and effort we can determine the Velocity Ratio of a machine as shown in Example 5.

Example 5

When using a chain block the hand chain moves 20m to lift the load 100mm. What is the velocity ratio?

Known information : Distance moved by effort = 20m

Distance moved by load = 100mm = 0.1m

$$\text{If } VR = \frac{\text{Distance moved by effort}}{\text{Distance moved by load}} \quad \text{Then } VR = \frac{20}{0.1}$$

$$\text{Hence } VR = 200$$

If we know the VR and the distance moved by the effort we can calculate the distance moved by the load, as shown in Example 6 overleaf.

Example 6

A lifting machine has a VR of 20, if the effort moves 5m how far will the load move?

Known information : VR = 20

Distance moved by effort = 5m

$$\text{If } VR = \frac{\text{Distance moved by Effort}}{\text{Distance moved by load}}$$

$$\text{Then Distance moved by load} = \frac{\text{Distance moved by effort}}{VR}$$

$$\text{So distance moved by load} = \frac{5}{20} = 0.25\text{m}$$

$$\text{Hence Distance moved by load} = 250\text{mm}$$

It therefore follows that we can also calculate the distance the effort must move to move the load a given distance if we also know the VR, important in calculating winch capacities, again when considering operator fatigue etc.

EFFICIENCY

No matter how well a machine is designed we can never get out more in total than we put in, in fact we get out far less. This is due in the main to **Friction**, which is the enemy of movement. For example, in a simple pulley a loss of between 5% - 8% of the force is accounted for by Friction in the sheave, therefore the more sheaves the greater the loss and the lower the **Efficiency** as the friction is cumulative.

We can determine the Efficiency by comparing the total input with the total output and this is known as **Work Done**.

In a lifting machine the **Work Input** is the effort and distance moved by the effort, the **Work Output** is the load and distance moved by the load. The Efficiency will therefore be the Work Output divided by the Work Input. As shown below, we can also see that load divided by effort is the MA and that distance moved by the load divided by the distance moved by the effort is the inversion of VR and therefore Efficiency can also be expressed as MA divided by VR.

Efficiency is then expressed as a percentage of the Work Done.

$$\text{Now efficiency} = \frac{\text{Work Output}}{\text{Work Input}}$$

$$\text{So, efficiency} = \frac{\text{Load} \times \text{Distance Moved By Load}}{\text{Effort} \times \text{Distance Moved By Effort}}$$

$$\text{Now as } \frac{\text{Load}}{\text{Effort}} = \text{MA} \text{ and } \frac{\text{Distance Moved By Load}}{\text{Distance Moved By Effort}} \text{ is the}$$

Inversion of VR which expressed as $\frac{1}{\text{VR}}$ we can say

$$\text{Efficiency} = \text{MA} \times \frac{1}{\text{VR}} \text{ or } \frac{\text{MA}}{\text{VR}}$$

Efficiency is expressed as a percentage so we say :

$$\text{Efficiency} = \frac{\text{MA}}{\text{VR}} \times 100$$

We can therefore calculate the Efficiency of a machine as shown in Example 7.

Example 7

A machine has a Velocity Ratio of 30 and a Mechanical Advantage of 24. Calculate the Efficiency of the machine.

Known Information : VR = 30

$$\text{MA} = 24$$

$$\text{If efficiency} = \frac{\text{MA}}{\text{VR}} \times 100$$

$$\text{Then efficiency} = \frac{24}{30} \times 100$$

Hence Efficiency of the machine = 80%

Now if we know the Efficiency and VR of a machine we can calculate the load that can be lifted by any given effort as shown in Example 8.

Example 8

A lifting machine has an Efficiency of 70% and a Velocity Ratio of 10. Calculate the load that can be lifted when an effort of 40kg is applied

Known Information : Efficiency = 70%

$$VR = 10$$

$$P = 40\text{kg}$$

$$\text{If efficiency} = \frac{MA}{VR} \times 100 \text{ then } MA = \frac{\text{Efficiency} \times VR}{100}$$

From the known information we can therefore calculate the MA thus :

$$MA = \frac{70 \times 10}{100} \text{ Therefore } MA = \frac{700}{100} \text{ Hence } MA = 7$$

Now we already know that $MA = \frac{W}{P}$ therefore $W = P \times MA$

So that $W = 40 \times 7(\text{kg})$ Hence Load that can be lifted = 280kg

By careful design we are able to vary the relationships of VR and MA to give a machine most suitable for a defined duty. We can also use the Efficiency to our advantage, for example if a machine has an Efficiency of less than 50% it will be self-sustaining. Many winches are designed this way and do not have a brake.

FRICTION

Earlier we said that a simple pulley suffers a loss of efficiency of between 5% - 8% due to Friction. The Friction here is largely between the sheave and the axle pin, **Frictional Force** is the resistance, which is offered when one body is made to slide over another.

The Frictional Force depends on the type and condition of the contacting surfaces and the normal reaction between the surfaces. Considering a weight being moved on a horizontal surface then the normal reaction is equal to the weight.

This relationship between the frictional force and the normal reaction is called the **Coefficient of Friction**. We use the Greek letter μ to signify this.

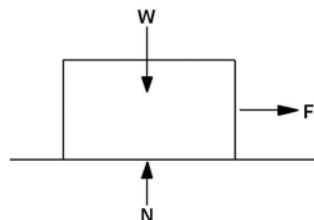

Figure 5

Figure 5 represents a body sitting on a level surface where: -

W = Weight of body

N = Normal Reaction of body on surface

F = Force required to just start body moving (ie the Frictional Force)

Now for a horizontal surface $W = N$

$$\text{Coefficient of friction } (\mu) = \frac{F}{N} \text{ will also} = \frac{F}{W}$$

$$\text{So } F = \mu W$$

Example 9

Calculate the force needed just to move a crate on a concrete floor. The crate weighs 1500kg and the Coefficient of Friction (μ) is 0.25

Known Information : $W = 1500\text{kg}$

$$\mu = 0.25$$

If $F = \mu W$ then $F = 0.25 \times 1500$

Force required = 375kg

SELF SUSTAINING LIFTING MACHINES

From the above text and examples we can see the relationship of the three properties MA, VR and Efficiency. We can see that the Mechanical Advantage will always be less than or equal to the Velocity Ratio otherwise the machine would have an Efficiency greater than 100%, which of course is not possible, and that this loss of Efficiency is due to Friction.

Most lifting machines, eg chain blocks, screw jacks etc, are required to be **Self Sustaining**. In other words when the effort is removed they hold the load and do not reverse or run back. We can use the effects of Friction and resulting loss of Efficiency to our advantage here. In the case of a modern chain block a Friction Brake is usually fitted to achieve this whereas a screw jack relies purely on Internal Friction, ie an Efficiency of less than 50%. Let us consider this aspect.

If we have a machine where the Effort P moves a distance x while the Load W moves a distance y, then the Lost Work in the machine will be $Px - Wy$. When the effort is removed the machine tends to reverse so that W now becomes the effort acting on the machine. If the Lost Work remains the same, the machine will operate in reverse only if the work provided by the new effort is greater than the work lost.

So to operate in reverse , Wy must be greater than Px Wy .

$$\text{That is, } \frac{Wy}{Px} \text{ must be greater than } 1 \frac{Wy}{Px}$$

$$\text{and this can only occur if } \frac{Wy}{Px} \text{ is greater than } \frac{1}{2}$$

As we have already seen in the above text $\frac{Wy}{Px}$ is the efficiency of the machine

so we can also see that a machine will not reverse when the effort is removed if the efficiency is less than 50%.

We can see then that machines can be specifically designed so that their Efficiency is less than 50% and so that they will be Self Sustaining, as in the case of the screw jack.

MOVING BODIES

When a body is moved at velocity along a plane, there are four forces acting upon that body, the system of forces being in Equilibrium. These forces are:-

1. The weight of the body, which acts vertically downwards.
2. The force causing motion.
3. The Normal Reaction between the body and the plane.
4. The Frictional Resistance opposing motion. This acts parallel to the plane and its magnitude is equal to the product of the Coefficient of Friction and the Normal Reaction between the body and the plane.

These are shown in Figure 6.

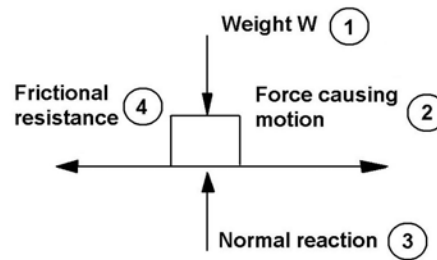

Figure 6

We can simplify matters by applying a Triangle of Forces to reduce this from a four force system to a three force system. Since the Normal Reaction and the Frictional Resistance are related to each other we can combine these into a single reactive R as in Figure 7.

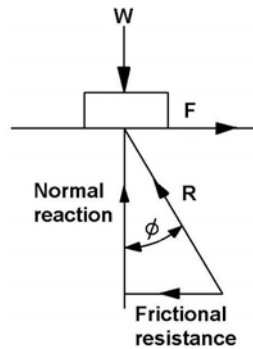

Figure 7

$$\tan \phi = \frac{\text{Frictional Resistance}}{\text{Normal Resistance}} = \mu$$

The reaction R comes ‘from the plane’ and is positioned at an angle ϕ to the normal, where: The direction with respect to the normal is such that R has a component, which is opposite to the direction of motion.

FRICITION ON AN INCLINED PLANE

We can now develop formulae to calculate the force that is necessary to maintain constant velocity of a body on an inclined plane.

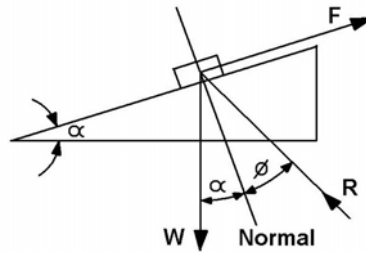

Figure 8

Figure 8 shows a body on a plane inclined at angle α . The weight W acts vertically downwards, the motivating force F is parallel to the surface of the incline, the plane reaction R is at ϕ to the normal. The body is then moving up the plane.

From the force diagram (Figure 8) we can produce a vector diagram as Figure 9. Points 0 , a , b and c are identified to enable us to use trigonometrical calculations to solve the triangle.

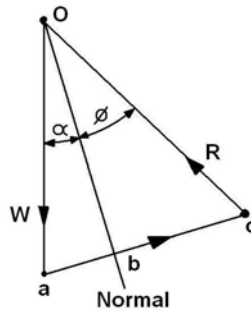

Figure 9

If the body were moving down the incline it would appear as shown in Figure 10 and the resulting vector diagram as Figure 11.

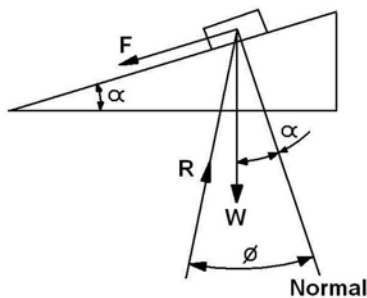

Figure 10

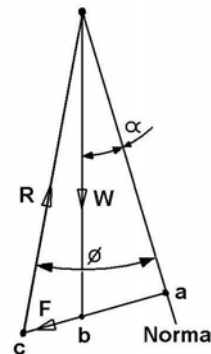

Figure 11

NB: If $\mu \cos \alpha = \sin \alpha$ the force required to cause motion is zero. The body would slide down the plane at constant velocity without any external force being applied. If the angle α is less than ϕ then additional force will be necessary, if the angle α is the same as ϕ then the body will move without aid and if the angle α is greater than ϕ the body will accelerate unaided.

Although the above has been largely unexplained you will realise that the vector diagrams and the formulae that can be produced from them are of help to us in various ways. Perhaps the most important is for winching operations in calculating the capacities and brake forces required to handle loads safely.

THE SCREW

Let us now combine the elements we have discussed in this unit and see how we may apply them to a simple lifting machine, the screw jack.

A square threaded screw can be considered as an inclined plane wrapped around a cylinder, the angle of the plane being the helix angle of the thread at its mean diameter.

- If α = The angle of the plane
- N = Number of starts of the screw thread
- P = The pitch of the screw thread
- d = The mean distance of the screw thread

$$\text{Then } \tan \alpha = \frac{NP}{\pi d}$$

In the case of a screw jack being used to lift a load the effort is applied horizontally. A diagrammatic representation and the resulting vector diagram are shown in Figure 12.

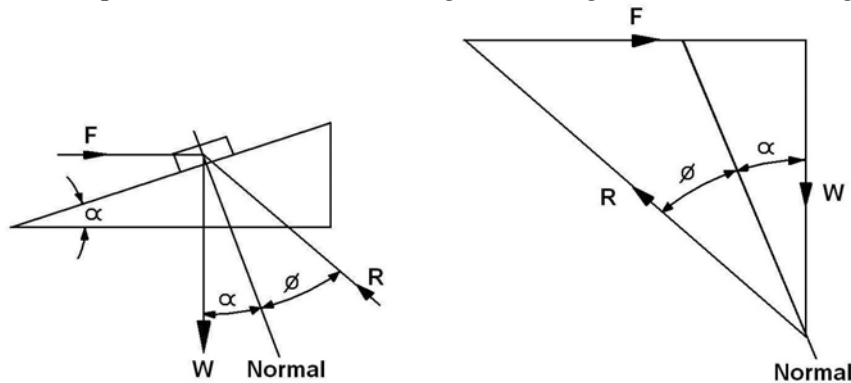

Figure 12

$$\text{Here } \frac{F}{W} = \tan(\phi + \alpha) \text{ therefore } F = W \tan(\phi + \alpha)$$

ϕ being arc Tan μ where μ is the coefficient of friction.

If we now take moments about the centre of the thread,
 effort x radius of effort = F x mean radius of screw thread.
 This enables us to determine the effort and from the equation:

$$\frac{MA}{VR} = \text{Efficiency}, \quad VR = \frac{2\pi R}{np} \quad (\text{see Figure 13})$$

The efficiency at a particular loading can be determined

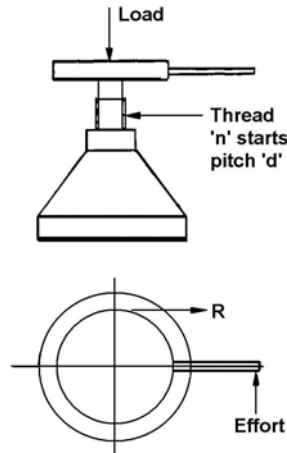

Figure 13

PULLEY BLOCK ARRANGEMENTS

The pulley block is one of the simplest and most common lifting machines, so we will take a closer look at them. The type with which we are concerned consists of a number of pulleys or sheaves freely mounted in pulley blocks. A single piece of rope is passed over each pulley in turn. One end is fastened to either the top or bottom pulley block, dependent on the number of pulleys. The effort is applied to the free end of the rope and the load is attached to the lower pulley block. Three simple arrangements of pulley blocks are shown below:

Velocity Ratio equals number of pulleys which equals number of falls of rope

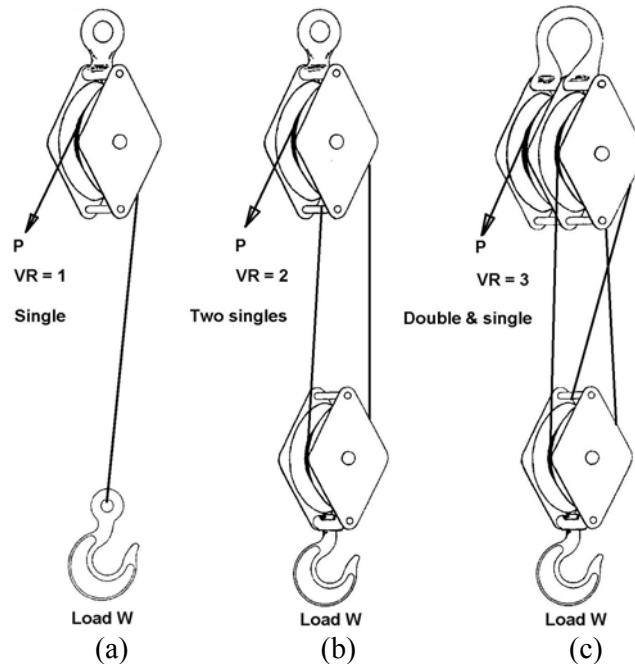

Figure 14

Let us consider each of these arrangements in turn. In all these considerations we will assume we have perfect pulley arrangements, which involve:

- (a) Frictionless pulleys
- (b) Weightless ropes
- (c) Weightless lower block and hooks

Figure 14(a) shows a single pulley block in its basic form. This serves only to reverse the direction of the pull and we can therefore say the Effort P is equal to the Load W, and the distance travelled by P is equal to that through which W moves in the same time.

$$\therefore \text{if } MA = \frac{W}{P} \text{ Then } MA = 1 \text{ So the MA is 1}$$

$$\text{Also if } VR = \frac{\text{Distance moved by effort}}{\text{Distance moved by load}} \text{ Then } VR = \frac{1}{1} \text{ So the VR is 1}$$

$$\text{And finally if } \text{Efficiency} = \frac{MA}{VR} \text{ Then } \text{Efficiency} = \frac{1}{1} \times 100$$

So the Efficiency is 100%

Figure 14(b) shows a two pulley arrangement with a single sheave top pulley block and a single sheave bottom block. This is the most basic form from which the operator gains an advantage from the MA, but at a cost, consider the effect of the VR.

It will be seen that the load W is now supported by two parts (falls) of rope so that the load in each fall is $\frac{W}{2}$. As the loads in the rope on either side of the top pulley must be equal in our perfect pulley arrangement, the Effort P must be equal to $\frac{W}{2}$.

$$\therefore MA = \frac{W}{P} = \frac{W}{\frac{W}{2}} \text{ So the } MA = 2$$

Equally we can see that for each unit of distance travelled by the effort the load will only move half that distance and therefore

$$VR = \frac{2}{1} = 2$$

Figure 14(c) also shows a two block arrangement but here the top block has two sheaves and the bottom block only one, this then is a three pulley block system. The operator gains further advantage from the MA, but at greater cost, consider now the effect of the VR.

The Load W is now supported by three parts (falls) of rope so that the load in each fall is $\frac{W}{3}$, the Effort P must also equal $\frac{W}{3}$.

This means that the MA = 3 and that the VR = 3.

In general we can therefore see that the Velocity Ratio of any pulley block system, having equal diameter pulleys and reeved with a single rope, is equal to the total number of pulleys. This Velocity Ratio will not change when we consider the more normal case taking Friction into account. Friction will however have the effect of lowering both the Mechanical Advantage and the Efficiency, which can be calculated in the usual way. Although we ignored the effect of friction on pulley blocks we can note that simple pulley arrangements will not be self-sustaining.

In his day-to-day duties the Tester and Examiner does not need a detailed knowledge of 'The Law of Machines', 'Limiting Mechanical Advantage' or 'Limiting Efficiency'. They do however need sufficient understanding of the basics to enable them to assess the suitability of a lifting machine for the duty it is to perform. For instance they should be able to determine if the operation is fast/slow enough for the application, also the effect on the operator (ie fatigue) due to the effort required or distances to be moved and whether or not the machine will be self sustaining. It is hoped that by having worked through this unit and the following assignment you will have gained sufficient understanding of the subject.

UNIT NO 1.19

REVISION ASSIGNMENT

We are now reaching the end of training course 1, the intention of which has been to give you the necessary background information, which, together with your day-to-day practical experience, will enable you to pass the Association's Part 1 Examination.

Although Part 1 Entry is not a qualification, but only a demonstration that you have a broad overall background understanding, it is a necessary first step that you pass the exam before you can move on to take one of the specialised subjects to obtain a qualification.

Throughout the course, the Assignments have been multi-choice papers, as this is the method of questioning used in the Part 1 examinations. The vast majority of the questions have drawn directly on the text of the unit that they accompany, although in a few cases reference to other publications, such as the Code of Practice for the Safe Use of Lifting Equipment and British Standards, may have been necessary. Therefore, it has not been too difficult to obtain good marks in the Assignments, as the matters are fresh in your mind having just read the text.

This unit, together with Unit 1.20, are Revision Assignments, which set out to replicate the actual examinations. Remember, in the examinations you will be given 1 hour to answer 100 questions. The pass rate for the examination is 65%. Both Unit 1.19 and Unit 1.20 ask 50 questions, so you can use your combined mark to assess how you would have fared if this had been the exam.

Remember, there are no trick questions. To each question asked there is only one correct answer, and this will have been dealt with in the text of the relevant unit, standard or in the Code of Practice for the Safe Use of Lifting Equipment.

ANSWER ALL FIFTY QUESTIONS by placing X in pencil by the answer of your choice. Should you change your mind, erase the first X and place a new X in the box corresponding to your new answer.

To help in your preparation, it is suggested that you approach this in the way you would if it were the actual exam. It is therefore suggested that you read through the questions marking only the answers of which you are certain. Once you have worked through the paper in this way, return to the beginning and answer those questions you initially passed. This should still leave you time to scan the paper making any corrections you may feel necessary.

Once the marked paper is returned to you, look through it noting those questions you got wrong, use them as a basis for your revision programme. Remember last minute revision seldom helps, in fact it often hinders, but a subject well learnt and constantly revised is never forgotten. To this end little and often is of far more benefit than long sessions.

UNIT 1.1

THE LAW

INTRODUCTION

The 1990's was a time of great change as far as industrial law is concerned. With the creation of the European Union there was a need for common requirements throughout the member states so that the free movement of equipment and persons could be achieved with safety. This has been done by the implementation of European Directives and their transposition into the laws of the member states. The main Directives have already appeared as UK regulations, with similar laws being introduced in the other member states of the European Community. Several other countries, mainly the members of EFTA, have also adopted similar legislation so that much of the current industrial legislation is the same throughout Europe and beyond.

Two types of Directives affect us, those that remove barriers to trade and those concerning health and safety. Due to the differences in national practices and laws in the member states, the pioneering nature of introducing common requirements and the obvious difficulties due to the number of languages in use in the countries involved, changes to the requirements will be necessary from time to time by way of amending legislation until we get it right for all concerned. In some cases this may change the way we conduct our business and we need to be aware of any changes that take place.

This is particularly true in the field of lifting equipment. Lifting has always been identified as an industrial practice that calls for special measures to ensure safety. As a result, legislation has contained requirements; both for the design and condition of the equipment and for the way it is used.

Traditionally, the requirements for lifting equipment were given in the Factories Act and several sets of industry specific regulations, which augmented or modified those requirements. The requirements concerned both the design and use of the equipment. Whilst it served us well, much of the legislation became dated and there were several anomalies between the various requirements. Some areas where lifting equipment is used, eg schools, hospitals and farms, were missed by this legislation and in some cases common items of lifting equipment were missed.

It was realised in the 1970's that broader safety legislation was necessary. The Health and Safety at Work etc Act 1974 was put in place to cover all work situations and to ensure the safety of people at work or those who might be affected by the actions of people at work. The Act is goal setting, giving the aims and achievements to be met but not specifying how this must be done. Referring to employment and equipment in general, rather than specific categories, the Act has the effect of unifying the basic safety requirements and acts as an 'umbrella' for all of the other regulations. Although many changes have since taken place, the Health and Safety at Work etc Act 1974 remains in place and continues to be the umbrella for all of the other industrial legislation.

In 1992 the European Machinery Directive was implemented in UK law by the Supply of Machinery (Safety) Regulations 1992. This legislation is concerned with the design, manufacture and initial placing on the market of machinery and includes lifting equipment and lifting accessories. The effect of this legislation was to 'disapply' those parts of the older legislation that referred to the design, manufacture and first taking into use of lifting equipment.

At the same time another European Directive, the Use of Work Equipment Directive, was implemented in the UK by the Provision and Use of Work Equipment Regulations 1992.

However, this did not specifically refer to lifting equipment and so the older legislation was temporarily left in place to cover its use. This Directive has now been amended to include lifting equipment. To implement the amendment, the 1992 regulations were repealed and replaced by the Provision and Use of Work Equipment Regulations 1998. This legislation was supplemented by a further set of regulations, specific to lifting operations, known as the Lifting Operations and Lifting Equipment Regulations 1998. These two sets of regulations repealed or revoked all of the older legislation that referred to the use of lifting equipment and replaced them with a common set of requirements, thus catching all of those areas and equipment which were previously missed.

EARLIER CHANGES TO LEGISLATION

One of the major effects of changes to legislation we notice as testers and examiners of lifting equipment is that of the necessary documentation which allows lifting equipment to enter and remain in service. As, in most cases, the initial documentation remains valid for the life of the equipment and as some items of lifting equipment have long working lives, we will encounter documents issued under older legislation from time to time in the course of our duties. We therefore need to be able to recognise the various documents and understand their significance.

The Factories Act 1961 and the various industry regulations issued under the Act called for the results of tests and examinations to be recorded on certain forms (eg F86, F88 and F97). However, this was a very confused situation, as different forms were required by the different legislation. Often a manufacturer had little idea under which regulations his equipment would be used, so it was a matter of potluck if he issued the correct 'test certificate'.

The first major change to the specific regulations came with the Docks Regulations 1988, which repealed and replaced the older 1934 Docks Regulations. These were the first regulations, which specifically referred to lifting equipment, to be issued under the Health and Safety at Work etc Act. The Health and Safety Executive also published an Approved Code of Practice (ACoP) to accompany these regulations. Written in a clear and easily read style, it reflected up to date thoughts and practices, indicating the way forward for changes to other legislation.

The Docks Regulations 1988 made a long overdue change to the requirements for recording the results of tests and examinations by omitting earlier references to prescribed forms and simply listing the information to be recorded. This change was extended to the remaining legislation by the Lifting Plant and Equipment (Records of Test and Examination etc) Regulations 1992 and this approach is being continued in the new regulations.

The need to implement European Directives provided a further opportunity to review the old legislation and resulted in the introduction of the new UK legislation. Whilst both the regulations mentioned here were repealed or modified in December 1998, the changes they made are reflected in the new legislation.

EUROPEAN DIRECTIVES

We said that the new UK industrial legislation is the result of European Directives, so before we consider the specific legislation that refers to safety and to lifting equipment let us note what a European Directive is and how it affects us.

A Directive is not law, but is an instruction to the governments of the member states to introduce national laws in line with the requirements set out in the Directive and to withdraw any existing legislation that may be contrary to this. In the UK we do this by introducing regulations made under the Health and Safety at Work etc Act 1974 or under the European Communities Act 1972.

However we must meet the requirements of the Directives in full and, to do this, the UK regulations make direct quotes from the text of the Directives. This causes us a little difficulty as the terms and descriptions used are often very different from those which we are used to, and so we need to understand these new terms and they will be considered later in our studies.

OVERSEAS MEMBERS

The association now have a large number of overseas members who have their own legislation and will not be familiar with European Legislation. In order to assist our overseas members we advise them to study the BEST PRACTICE guidance at the end of each specific part of legislation. By following the BEST PRACTICE guidance you should be doing enough to work to the legislation of your own country. In many cases, especially those related to Oil and Gas Exploration, where no special legislation exists the exploration and production companies call up the requirements of the United Kingdom legislation.

PRIME SAFETY LEGISLATION

The Health And Safety At Work Etc Act 1974

The Health and Safety at Work etc Act 1974 makes goal setting requirements and places duties on everyone at work to ensure health and safety. It is written in broad terms that support the aims of all health and safety legislation. It therefore remains in place as a long stop, bringing all of the other regulations together under its umbrella.

The Act is administered by the Health and Safety Commission, which is empowered to approve and issue codes of practice that give practical guidance on the requirements of the various regulations. Under the control of the Commission is the Health and Safety Executive (HSE), who are responsible for the day-to-day enforcement of the Act and various regulations. There are several branches to the HSE but it is the Field Officers (formerly known as Factory Inspectors) who the tester and examiner is most likely to meet in the course of their duties and it is to them that copies of defect reports have to be sent, as we will see later.

Although the Act is extensive we need only consider three of the 85 Sections this contains and will therefore look at Sections 2, 6 and 7.

Section 2

Section 2 lays down the broad duties of the employer with regard to the safety of his employees. The opening to section 2 states:

"It shall be the duty of every employer to ensure, so far as is reasonably practicable, the health, safety and welfare at work of all his employees"

Specifically this Section requires that the employer:

- (1) Provides and maintains safe systems of work
- (2) Ensures that risks in the handling, transport and storage of articles and substances are minimised
- (3) Provides such information, instruction, training and supervision as necessary to ensure the health and safety of his employees
- (4) Provides and maintains a safe place of work with safe access to, and egress from it without risks
- (5) Provides and maintains a safe working environment and adequate welfare arrangements

These requirements are then far reaching and, as many of the requirements are more detailed in other Regulations, requires the employer to ensure that ALL the applicable related legislation is met in full.

In the opening statement the key words are "reasonably practicable". This is taken to mean that a calculation must be made as to the risk against sacrifice (money, time or trouble) involved in averting the risk. The employer has satisfied this requirement if the risk is insignificant against the sacrifice in averting that risk.

As an example: if an employer did not carry out proper maintenance, inspections, examinations and testing, claiming that the sacrifice (eg cost of the tester and examiners work) was too high, then they would clearly not be taking all reasonably practicable steps to ensure the safety of their work force. On the other hand, it would not be reasonably practicable for an employer to have all their equipment checked by X ray analysis at every inspection.

Best Practice

The employer should:

- (1) Provide and maintain machinery along with introducing safe systems of work thereby assuring so far as is reasonably practicable the health and safety of his employees.
- (2) Make arrangements to ensure that all risks with regard to the use, handling, storage and transport of articles and substances are minimised.
- (3) Provide information, instruction, training and supervision as is deemed necessary in order that the employee can work safely.
- (4) Provide and maintain a place of work keeping it in a safe condition and without risks to health also ensuring access and egress from it are safe.
- (5) Provide and maintain a working environment that is safe and without risks to health also provide adequate welfare arrangements.

Section 6

Section 6 lays down the broad duties of the designer, manufacturer, importer, installer and/or supplier. Again many of these requirements are more detailed in other legislation and it implies that such requirements must be met in full. This section was amended in March 1988. It will be seen that the requirements relate to similar requirements placed on employers, thus strengthening the area of responsibility. The opening sub-section of this Section states:

"It shall be the duty of any person who designs, manufactures, imports or supplies any article for use at work or any article of fairground equipment:

- (a) to ensure, so far as is reasonably practicable, that the article is so designed and constructed that it will be safe and without risks to health at all times when it is being set, used, cleaned or maintained by a person at work;
- (b) to carry out or arrange for the carrying out of such testing and examination as may be necessary for the performance of the duty imposed on him by the preceding paragraph;
- (c) to take such steps as are necessary to secure that persons supplied by that person with the article are provided with adequate information about the use for which the article is designed or has been tested and about any conditions necessary to ensure that it will be safe and without risks to health at all times as are mentioned in paragraph (a) above and when it is being dismantled or disposed of; and
- (d) to take such steps as are necessary to secure, so far as is reasonably practicable, that persons so supplied are provided with all such revisions of information provided to them by virtue of the preceding paragraph as are necessary by reason

of its becoming known that anything gives rise to a serious risk to health or safety".

Sub-section 3 also imposes legal duties on erectors and installers. Whilst sub-section 9 makes it clear that Section 6 covers new and second-hand articles, whether for sale or hire, and their component parts. When an article or substance is obtained on hire purchase, unlike domestic legislation, it is the "supplier" and not the credit company who is responsible. It is important to note that the provisions apply equally to British and foreign products. Importers and suppliers have the same duties as designers and manufacturers, and are required to provide the same standards of safety and information as British suppliers.

The opening sub-section requires the supplier to provide the purchaser with adequate information about the care and safe use of the item, and to update this information if found necessary. In their explanatory leaflet the HSE say "In seeking to ensure safety, since operator error or inattention are reasonably foreseeable they should be taken into account, but reckless use or use for wholly inappropriate purposes need not. In criminal proceedings, courts will pay attention to any relevant advice provided to users, for example precautions to be taken or actions to avoid, in deciding whether the duties have been complied with".

As an example, let us take this one requirement and link it to the duties of employers and employees. We have a requirement for the supplier to provide information on the safe use to the purchaser. This links to the requirement for an employer to instruct and provide information on the use to their employees. If an employer allows equipment to be used without regard to any relevant information or advice relating to its use, made available by the supplier, then in the event of an accident they cannot expect to seek compensation from the supplier. However, if the supplier did not provide information, or suitable information, then the supplier would be at fault.

Best Practice

The designer, manufacturer, importer, installer and supplier of articles for use at work should:

- (1) Design and construct any article so that when it is used in a proper manner there is no risk to the health and safety of the workforce.
- (2) Test and examine as is necessary any article to be used in the workplace to confirm that it will give no risk to the health and safety of the workforce.
- (3) Supply adequate information about the article regarding the use, testing and any condition necessary for its safe use in the workplace.
- (4) Supply revisions of information regarding any changes to equipment which may give rise to risks to health and safety in the workplace.

Section 7

Section 7 lays down the broad duties of employees, this states:

"It shall be the duty of every employee while at work, to take reasonable care for the health and safety of himself and of others who may be affected by his acts or omissions at work; and as regards any duty or requirement imposed on his employer, or any other person by or under any relevant statutory provisions, to co-operate with him so far as is necessary to enable that duty or requirement to be performed or complied with".

Whilst this may seem reasonable, it should be emphasised that as an employee, each person has a duty in law to look after his own health and safety as well as that of others.

The final part of this section completes the link with the duties of others. If we look again at our example regarding the requirements for information on the safe use: this section implies the need

to take part in training and to comply with the instructions originally issued by the supplier and passed down by the employer at these training sessions or in written work procedures.

As the result of European Directives, there are two sets of regulations which have been issued under the Health and Safety at Work etc Act that we should note here as they add to the prime requirements of the Act. We do not need to consider them in detail, but only to note one or two matters which may affect us as testers and examiners of lifting equipment.

Best Practice

The employee at work should:

- (1) Take care of the health and safety of themselves and others who may be affected by their work or failure to carry out some of their work.
- (2) Co-operate with their employer to take part in training or instruction from suppliers to enable work to be carried out in accordance with any regulations.

The Manual Handling Operations Regulations 1992

These regulations refer directly to lifting operations and add to the employers duties in Section 2 of the Act. They require an assessment to be made of any operation where loads are handled manually, or where manual effort is necessary, with a view to reducing the number of injuries that result from such operations. They require the introduction of lifting appliances where the risks are high or if the operation can be made safer by their introduction. For instance, if loads are being lifted by hand the risks may be reduced to more acceptable levels by using a hand chain block. In another case, if a hand chain block is in constant use the introduction of a power operated block may result in the risk of injury being reduced even further.

The Management of Health and Safety At Work Regulations 1999

These regulations modify both Section 2 and Section 7 of the Act. They underline the requirements for employers to provide instruction and training. They must ensure that their personnel are properly trained to use any equipment necessary in the course of their work, but the regulations also place an obligation on employees to undergo such training and follow the instructions given by their employer. Operatives are required to only use equipment for which they are trained and to use it in the manner and for the purpose for which they have been trained.

We can see from the above that the Health and Safety at Work etc Act links with any other legislation which may impose a duty or requirement and that it requires that those duties are met in full. Let us then consider the regulations that affect the design, manufacture and use of lifting equipment as well as those that directly affect us as testers and examiners of lifting equipment.

Best Practice

- (1) Employers will have their personnel trained to use equipment which they use in the normal course of their work.
- (2) Employees will undergo any such training or instruction required by the employer.
- (3) Operatives should only use equipment for which they are trained and to use it in a manner in which they have been trained.

LEGISLATION CONCERNING THE DESIGN, MANUFACTURE AND SUPPLY OF LIFTING EQUIPMENT

We said that earlier legislation concerning lifting equipment covered the design, manufacture, supply and use with common requirements. Current legislation divides these duties in a more logical way. There is legislation that the designer/manufacturer of new lifting equipment must comply with and separate legislation that the user must meet. The main requirements for new

lifting equipment are given in the European Machinery Directive, which is enacted as the Supply of Machinery (Safety) Regulations in the UK.

Supply of Machinery (Safety) Regulations 1992

These regulations implement the European Machinery Directive and an amendment to that Directive that introduces lifting equipment to the requirements. The regulations are intended to remove barriers to trade and allow the free passage of goods between the member states of the European Union by recognition of common safety requirements in all of those states.

They became effective from the 1st January 1993 but allowed a transitional period until 1st January 1995 from which date they became mandatory. Further amendments have been made in a separate set of regulations, known as The Supply of Machinery (Safety) (Amendment) Regulations 1994. Although separate, they must be read in conjunction with the original regulations and be considered as part of them. Our discussions in this unit therefore consider them as a whole and refer only in name to the original regulations. We can also note that a further amendment has been published as a new directive which has to be introduced into national law during 2009, although it may be introduced before to enable us to get used to new requirements.

As the name suggests the regulations only concern the supply of equipment, which is defined as its design, manufacture and supply including first taking into service. Thus new equipment which complies with the Directive is generally permitted to enter service in any of the member states without further verification being necessary. These regulations are the prime legislation for new lifting equipment that adds to the requirements Section 6 of the Health and Safety at Work Act.

Section 4 of the Supply of Machinery (Safety) Regulations addresses those requirements to offset the particular hazards due to a lifting operation. (Although we need not consider such matters in detail, this has the effect of bringing in some items not previously considered as lifting equipment by the older legislation, eg fork trucks, jacks etc) The hazards to be offset are identified as falling loads, tipping or overturning and collision. Equipment must be designed, made and, if necessary, tested to ensure that it is safe. Complying equipment must then be marked with the 'CE'* mark to signify its compliance with the Machinery Directive and an EC Declaration of Conformity must be issued by the 'responsible person'.

*The actual mark appears thus: C € , but is shown in normal type throughout this text for clarity.

The 'Essential Safety Requirements' effectively replace the requirements given in older legislation, ie at the start of Sections 26 and 27 of the Factories Act and similar requirements in the various regulations relating to design, construction and supply. Section 26 of the Factories Act said "No chain, rope or lifting tackle shall be used unless it is of good construction, sound material, adequate strength and free from patent defect" and Section 27 said "All parts and working gear, whether fixed or movable, including the anchoring and fixing appliances, of every lifting machine shall be, of good construction, sound material, adequate strength, free from patent defect and shall be properly maintained." These older requirements are of course still the relevant requirements for lifting equipment and apply to equipment supplied before 1 January 1995, which may still be found in service, and so the tester and examiner should remember them.

Manufacturers must issue information on the care and safe use of the equipment. This builds on the requirements of Section 6 of the Health and Safety at Work Act, the requirements for this information being far more detailed here.

The regulations give examples of coefficients of utilisation (factors of safety) and the static and dynamic overloads that the equipment must be designed to withstand, although they do not require it to be issued with a test certificate. There are also requirements for certain safety information to be marked on the equipment.

The actual working of the regulations need not concern the tester and examiner. LEEA has issued guidance to its members to assist them in complying with the legislation and to ensure they are all applying the rules in the same way. We should also note that the easiest way for a manufacturer to comply with the Directive is to work to Harmonised European Standards, an example of which is BS EN 818. Part 4 of the standard, with which most of you will be familiar, covers grade 8 chain slings.

Here we should note the important role of Harmonised European Standards. Firstly they have a quasi-legal status. Whilst no Harmonised Standard is in place the 'essential safety requirements' given in the Directive are the legal minimum, but once such a standard is in place it is the European Commission's view that the requirements of the standard then become the legal minimum. Secondly, a Harmonised Standard fulfils a large part of the manufacturer's 'technical file', so saving the manufacturer much time and work in putting the file together. However, in order to claim compliance, a manufacturer must comply fully with the standard with no deviation, no matter how minor he may consider it to be.

Of main importance to the tester and examiner is the documentation necessary for new lifting equipment.

In the past it was only necessary for a user to obtain a 'test certificate' for an item of lifting equipment for him to be able to take the item into service. These regulations change this and place the onus on the manufacturer, or other responsible person, to issue an EC Declaration of Conformity to permit the item to be supplied and enter service. In order to be able to do this, the manufacturer, or other responsible person, must be able to compile a Technical File for the item. The record of any tests or examinations made by him now only form a small part of this file.

The Directive (and therefore these regulations) require an EC Declaration of Conformity and not a test certificate. Some of the Harmonised Standards to which the manufacturer works require a 'manufacturer's certificate' to be issued with the product, although this does not include any verification information. In the UK it became the practice to issue combined records of verification with the declaration during the time that the old legislation remained current for the use and some manufacturers continue this practice, although not required by legislation.

Best Practice

- (1) Have lifting equipment designed, made and if necessary tested to ensure it is safe to use.
- (2) Mark equipment that complies with the regulations (In member states of the EEA, IEEC and EFTA, complying equipment is 'CE' marked)
- (3) Make sure all lifting machines are of good construction, have enough strength, be free of defects and are properly maintained.
- (4) Issue information on the care and safe use of lifting equipment.

The Electromagnetic Compatibility Regulations 1992

In the case of electrically operated lifting equipment, there is another European Directive with which the equipment must comply, the European Electromagnetic Compatibility Directive. This is implemented in the UK by the Electromagnetic Compatibility Regulations 1992.

These regulations are concerned with the emission of, and susceptibility to, interference. Manufacturers must build their equipment in such a way that it does not cause interference with other electrical equipment and so that it is not subject to the effects of interference emitted by other equipment. They must conduct any tests necessary to ensure that this is the case.

Whilst this is not a matter for the tester and examiner of lifting equipment, we should note that when the manufacturer affixes the CE mark to an item it implies that all the necessary directives have been complied with. The EC Declaration of Conformity for electrically operated lifting equipment should therefore refer to both the Machinery Directive and the Electromagnetic Compatibility Directive.

How Supply Legislation Affects The Testing Of New Lifting Equipment

The result of this legislation is to change some of the practices previously adopted by the industry. In the past it was a user's duty to obtain a test certificate for an item of lifting equipment before he took it into service. Although manufacturers had no obligations to issue test certificates, as a part of the service to the customer, suppliers have usually issued a test certificate, so allowing a new item to be taken into immediate service by the user. Some users have made items of lifting equipment for their own use, or had them made by a sub-contractor, eg lifting beams or runways, and then had them tested by a lifting equipment tester who has issued a test certificate, so permitting the item to enter service. In other cases, users have issued drawings and specifications of special items to a lifting equipment company who has then made the item, tested it and issued a test certificate to permit it to be taken into service.

Now, as we have seen, the test results only form a part of the 'responsible persons' technical file, which in turn enables them to issue the necessary EC Declaration of Conformity to permit the item to be supplied (enter service).

Where the supplier is also the manufacturer, he will issue the EC Declaration of Conformity.

Where a user has manufactured the item, or has had it produced by a sub-contractor, it is they who are the responsible person for issuing the necessary EC Declaration of Conformity and not the testing company. In this case the testing organisation cannot issue a 'test certificate', as this might imply that they are accepting a legal responsibility for the item. Here the testing organisation will issue a 'report of a test for inclusion in the responsible persons technical file'. Whilst this will resemble an old test certificate in many ways, it does not contain any statements as to the suitability of the item for service or as to its compliance with the Directive.

Where the user issues a drawing or specification to the lifting equipment organisation for them to manufacture and test the item, different requirements will exist depending on the commercial arrangements made. If the lifting equipment organisation acts solely as a sub-contractor, then the user is the responsible person and only a report of the test will be issued for inclusion in the customer's technical file. However, in some circumstances, the lifting equipment company may carry out a full design appraisal, compile a full technical file and accept the legal responsibility for the item. In this case they will take on the role of the responsible person and issue the EC Declaration of Conformity.

Another variation is where an agent is onwardly supplying a proprietary item, eg a hand chain block. In the past, the supplier usually issued his own test certificate for the item. With the changed requirements a test certificate is not required, but an EC Declaration of Conformity must have been issued. Series manufacturers will usually issue only one EC Declaration to cover all of

the production of a particular design. Thousands may be made, but there will only be one Declaration. As it is not acceptable to issue copies of Declarations the supply company will issue a report of thorough examination under the use legislation, with an assurance of compliance with the Directive. In other cases, where the item is not identifiable to a particular manufacturer, the supplier may wish to treat the manufacturer as a sub-contractor and compile their own technical file and issue the Declaration.

These variations should not worry the tester and examiner unduly, but he should be able to recognise the different documents and understand their meaning. You are advised to investigate the types of documents issued by your company and become familiar with the information they contain. It is important to remember that a Declaration of Conformity cannot be copied and the responsibility for its issue cannot be passed on from the legally responsible person. You should also note that the Declaration should be an original and that a warning has been issued as to the use and issue of copies.

Best Practice

Be able to recognise the documents your company issues and receives and be familiar with the information they contain.

LEGISLATION CONCERNING THE USE OF LIFTING EQUIPMENT

There are two sets of regulations which cover the use of lifting equipment, the Provision and Use of Work Equipment Regulations 1998 (known as PUWER) and the Lifting Operations and Lifting Equipment Regulations 1998 (known as LOLER).

Provision And Use Of Work Equipment Regulations 1998

The Provision and Use of Work Equipment Regulations 1992, implemented the European Use of Work Equipment Directive in the UK. These regulations did not mention lifting equipment; as a result it was necessary to leave the existing legislation that referred to the use of lifting equipment in place until new legislation was published. This resulted in a mix of requirements during that time, with manufacturers having to meet the new supply legislation, but with users still having to meet the older requirements. As interim arrangements, manufacturers combined the EC Declaration of Conformity they were required to issue to supply the equipment with the record of test that the user needed in order to take it into service.

The European Directive was then amended to include lifting equipment and new regulations were therefore issued in 1998. This is a safety Directive, which lays down the minimum safety requirements to be met. Unlike the supply legislation, member states are free to augment the requirements if they deem it necessary. The UK has therefore issued two sets of regulations, PUWER and LOLER, to cover the use of lifting equipment. Whilst the core requirements are the same as in other states, the detailed requirements have been tailored to suit the UK and may differ from elsewhere in Europe.

PUWER makes general requirements that apply to all equipment. Of particular note as far as lifting equipment is concerned is the duty on purchasers, and those who provide equipment for use by others, to ensure that the equipment complies with the relevant European Directive(s). Although equipment is CE marked to show compliance, an item of lifting equipment can be made up of several items each with their own CE mark. The only way to ensure the item complies is for the purchaser to obtain the EC Declaration of Conformity, which shows the details of the compliance or obtain a report of thorough examination with a confirmation of compliance.

We should also note that PUWER requires equipment to be maintained in a safe condition and for it to be regularly inspected to ensure it remains in a safe condition. It is worth noting that these obligations extend to tools and equipment (eg hammers, spanners etc) that employees may bring into the work place for their own use. These general requirements are given more specific meaning in relation to lifting equipment by LOLER.

Best Practice

- (1) Keep work equipment maintained in a safe condition and in good working order.
- (2) Keep a record of maintenance for work equipment.
- (3) Have regular inspections of the equipment to ensure it stays in a safe condition.
- (4) Make sure the equipment conforms to all local legislation.

The Lifting Operations and Lifting Equipment Regulations 1998

The Factories Act, and the industry specific regulations made under the Act, contained lists of equipment to which they referred. LOLER takes a different approach referring only to a lifting operation and any equipment used in that operation is considered to be lifting equipment. Regulation 2 defines 'lifting equipment' as 'any work equipment for lifting or lowering loads and includes its attachments used for anchoring, fixing or supporting it' and an 'accessory for lifting' as 'work equipment for attaching loads to machinery for lifting'. We can therefore see that the scope is very broad and catches a lot of equipment previously not considered to be lifting equipment.

The duty to comply with LOLER is placed on the 'employer', but Regulation 3 makes it clear that the term includes self employed persons who use lifting equipment and; as appropriate, persons who have control of lifting equipment; persons who use or supervise or manage the use of lifting equipment, or the way in which lifting equipment is used, to the extent of their control.

Regulation 4 refers to the selection and suitability of lifting equipment for the purpose and conditions under which it is to be used. It requires that the employer ensures that lifting equipment is strong enough and stable for the load and that the load itself, and anything attached to it and used in lifting it, is strong enough.

Regulation 5 makes the requirements for equipment used for lifting persons. It requires greater safety coefficients (factors of safety) than for other purposes.

Regulation 6 requires lifting equipment to be positioned and installed in such a way as to reduce as low as possible the risks of the equipment or load from striking persons; or the load from drifting, falling freely or being unintentionally released; and that it is otherwise safe.

Regulation 7 refers to the marking of equipment. It requires lifting machines and accessories to be clearly marked with the SWL. Accessories must be marked so that the characteristics for their safe use can be identified, eg with the grade mark and angle of rating. There is a further requirement that equipment designed for lifting persons is clearly marked to that effect, and equipment not designed for lifting persons, but which may be used in error for that purpose, eg a goods lift, is clearly marked that it is not designed for that purpose.

Regulation 8 deals with the planning, supervision and control of lifting operations.

Regulation 9 deals with the examination and inspection of lifting equipment and Regulation 10 deals with the records of lifting equipment. These have a direct bearing on the duties of the tester and examiner and contain some requirements that the competent person must meet. We will therefore consider them separately after this general look at LOLER.

Regulation 11 refers to the keeping of records and documentation.

We need not concern ourselves with the remaining requirements of this set of regulations, other than to note that there is a schedule of information to be recorded following a thorough examination.

Best Practice

- (1) Make sure the lifting equipment and any attachments is strong enough for each load and that it has adequate stability for its intended use.
- (2) Use a greater factor of safety when using lifting equipment to lift persons and only use equipment which is designed for lifting persons.
- (3) Install and position lifting equipment in such a way that you reduce the risk of the load from striking personnel, the load drifting, falling or being released.
- (4) Make sure all relevant information is marked on the lifting equipment including the SWL in any configuration. The marking of lifting equipment which is designed for lifting persons should be so marked, lifting equipment that is not designed for lifting persons but could be used in error should be marked that it is not designed for this purpose.
- (5) Ensure that every lifting operation involving lifting equipment is planned by a competent person, appropriately supervised and carried out in a safe manner. The person planning the operation should have adequate practical and theoretical knowledge and have experience of planning lifting operations.
- (6) Lifting equipment must be thoroughly examined.
 - (a) In accordance with an examination scheme.
 - (b) After an accident.
 - (c) After repair.
- (7) Report defects to the owner of the equipment and in the case of defects which could become a danger to persons send a report to the relevant authorities.
- (8) Keep all relevant information on the lifting equipment available for inspection.

LOLER Regulations Affecting The Duties of The Tester And Examiner (Competent Person) of In-service Lifting Equipment

In carrying out the examination of in-service lifting equipment, the tester and examiner is fulfilling the duty of the competent person on behalf of the employer (user). The practices adopted and documents issued by the competent person, and the legal duties that must be met are given in Regulations 9, 10 and Schedule 1 to Regulation 10 of LOLER, which we will consider in detail.

Examination of Lifting Equipment

Regulation 9 of LOLER refers to the 'Thorough Examination and Inspection' of lifting equipment. The first thing to note is that the regulation does not contain the words 'test' or 'testing', this is for legal reasons, but it is clear that a test may often be part of the examination. Similarly it only refers to a 'report of a thorough examination', and again it is clear that this includes the detail of any test made during the examination.

There are seven paragraphs to Regulation 9, so we will look at them in turn and consider what is required. We will also note some of the comments made in the ACoP and Guidance to this regulation. (The regulation is shown in italics)

- (1) *Every employer shall ensure that before lifting equipment is put into service for the first time by him it is thoroughly examined for any defect unless either -*
- (a) *the lifting equipment has not been used before; and*
 - (b) *in the case of lifting equipment for which an EC Declaration of Conformity could or (in the case of a declaration under the Lifts Regulations 1997) should have been drawn up, the employer has received such declaration made not more than 12 months before the lifting equipment is put into service;*
- or if it is obtained from the undertaking of another person, it is accompanied by physical evidence referred to in paragraph (4).*

The first thing to note is in the opening that says ‘put into service for the first time by him’. The requirement does not therefore only refer to new equipment, but covers secondhand equipment, hired equipment or even equipment he borrows from another person to make a single lift, which is used by him for the first time.

In the case of new equipment, he does not have to have it examined before he can use it if he holds the original EC Declaration issued by the manufacturer, and provided that the Declaration was not made more than twelve months before the item enters service.

In the case of secondhand, hired or borrowed equipment, he does not have to have it examined provided that he holds evidence of the current examination report passed to him by the owner.

Best Practice

- (1) Be sure the lifting equipment has been thoroughly examined before it enters service.
 - (2) Be sure second hand, hired or borrowed equipment has a current examination report before using it.
- (2) *Every employer shall ensure that, where the safety of lifting equipment depends on the installation conditions, it is thoroughly examined*
- (a) *after installation and before being put into service for the first time; and*
 - (b) *after assembly and before being put into service at a new site or in a new location,*
- to ensure that it has been installed correctly and is safe to operate.*

This is self-explanatory, for example a new runway fitted with a hoist would need to be tested and examined, as would a tower crane erected on a new site, whilst a hoist and trolley erected onto an existing runway would only need to be examined. This is to ensure the correct installation and that it is safe before it is used.

Best Practice

Where the safety of the lifting equipment relies on the installation:

- (a) Do a thorough examination after it has been installed.
- (b) Do a thorough examination after it has been assembled.

(3) *Subject to paragraph (6), every employer shall ensure that lifting equipment which is exposed to conditions causing deterioration which is liable to result in dangerous situations is -*

(a) *thoroughly examined -*

(i) *in the case of lifting equipment for lifting persons or an accessory for lifting, at least every 6 months;*

(ii) *in the case of other lifting equipment, at least every 12 months; or*

(iii) *in either case, in accordance with an examination scheme; and*

(iv) *each time that exceptional circumstances which are liable to jeopardise the safety of the lifting equipment have occurred; and,*

(b) *if appropriate for the purpose, is inspected by a competent person at suitable intervals between thorough examinations,*

to ensure that health and safety conditions are maintained and that any deterioration can be detected and remedied in good time.

Users have a choice; they may adopt maximum fixed periods of examination, similar to the requirements of older legislation. These are 6 monthly for lifting gear and 12 monthly for all other items of lifting equipment. Alternatively, they can adopt written schemes of examination drawn up by a competent person, which take account of such matters as the conditions and frequency of use, the type of load being handled and the environment. A good example would be a crane which is used infrequently in a clean environment. It would not be necessary to thoroughly examine every part of the crane at 12 monthly intervals, a scheme could be drawn up that paid greater attention to the lifting media and safety devices, but only looked at say wear of the wheel treads and the alignment every three or four years. This would need to be fully detailed to reflect the risk associated with the various component parts.

Irrespective of the option chosen for examination, if there was an unusual occurrence, eg a sudden and unexpected shock load, which may have caused damage, or a major repair affecting the load bearing parts or operation, the lifting equipment must be thoroughly examined before it is used again to ensure that it is still safe.

In addition to routine checks made by the operative before each period of use, other more detailed inspections may be necessary at regular intervals between the thorough examinations to ensure that no damage or deterioration has occurred. This again will depend on the associated risks.

Best Practice

- (1) Give lifting accessories and equipment for lifting persons a thorough examination every 6 months.
- (2) Give lifting equipment a thorough examination every 12 months .
- (3) Where lifting equipment has been used in a harsh environment or worked frequently to capacity, more frequent examinations can be scheduled.
- (4) Encourage users to make regular inspections and withdraw from use any equipment which may have been damaged, or become worn and pass it to a competent person for thorough examination.

- (4) *Every employer shall ensure that no lifting equipment -*
- (a) *leaves his undertaking; or*
 - (b) *if obtained from the undertaking of another person, is used in his undertaking, unless it is accompanied by physical evidence that the last thorough examination required to be carried out under this regulation has been carried out.*

This means that if an item of lifting equipment is transferred to someone else, lent or hired, or is used on their site, the site owner has a duty to ensure that it has been correctly examined and to see evidence of the current examination report. Similarly, the owner of the equipment has a duty to ensure that evidence of the current examination report goes with the equipment. For example, if you hire or lend equipment to someone, or are using an item of lifting equipment belonging to your company on another site, then the owner of the site must be shown or given evidence of the examination report and your company has a duty to provide this on all occasions.

Best Practice

- (1) The owner must not let any equipment leave his premises without proof that it has been given a thorough examination.
 - (2) The owner or site manager must be shown proof that the equipment has been given a thorough examination.
- (5) *This regulation does not apply to winding apparatus to which the Mines (Shafts and Winding) Regulations 1993 apply.*

This needs no explanation; there are specific regulations that cover this equipment, which need not concern us as they are outside the scope of our studies.

- (6) *Where lifting equipment was before the coming into force of these Regulations required to be thoroughly examined by a provision specified in paragraph (7), the first examination under paragraph (3) shall be made before the date by which a thorough examination would have been required by that provision had it remained in force.*

This simply says that existing test records and examination reports issued under the old legislation remain valid until their normal date of expiry.

The seventh paragraph of this regulation lists all of the old regulations, which are replaced by LOLER, and so are not listed here.

Throughout LOLER, and indeed PUWER, the term ‘competent person’ is used to mean a person competent for the particular duty or task to which the paragraph in which it is used refers. The ACoP to LOLER Regulation 9 states that the competent person carrying out a thorough examination of lifting equipment must have:

‘such appropriate practical and theoretical knowledge and experience of the lifting equipment to be thoroughly examined as will enable them to detect defects or weaknesses and to assess their importance in relation to the safety and continued use of the lifting equipment’.

This is very similar to the old definition used by the LEEA and given in the older legislation and standards, and so should already be familiar to you.

When referring to thorough examination, the ACoP says:

‘The risks which could arise from failure of the lifting equipment will determine how thorough the examination needs to be.’

In other words, there is a professional judgement to be made by the competent person as to what form the examination takes. Like a doctor, you do not operate on every patient to find out if they have a problem, only when there is cause for concern is a full operation necessary. However the examination must be thorough enough to ensure that the equipment is safe to operate until the next examination is due. For example, you may wish to have a chain block stripped down in order to examine all of the working parts if you believe there is reason to suspect the integrity. On the other hand, you may be happy to visually examine the block without such stripping down if it is a new block and there is no reason to suspect any internal problems.

We must link this with the ACoP reference to testing, which states:

‘The competent person should decide whether a test is necessary. The nature of the test method will also be a matter for a competent person: they should determine the most appropriate method of carrying it out.’

This wording recognises that a proof test is not always appropriate and that other forms of test, eg NDT, may be used. It leaves the decision as to what is required to the tester and examiner. The guidance notes explain that the design of some equipment is such that damage may be caused by conventional overload tests. The person making the examination, or any tests, must therefore base these on the equipment manufacturer’s instructions, standards and good working practices adopted by the industry. In reality, this is what has always happened in the past, a test is only made if it is necessary and meaningful in establishing the safety of the equipment. It must also be remembered that repetitive overloading and inappropriate testing can cause harm and shorten the life of a perfectly acceptable piece of equipment.

Best Practice

- (1) The competent person must make a decision on the equipment he is examining:
 - (a) Does it require stripping down?
 - (b) Does it require some form of testing?
 - (c) Will a visual examination tell me what I want to know?
- (2) When the competent person has finished his thorough examination he must be absolutely sure the equipment is safe to operate until the examination is due.

Reports and Defects

Regulation 10 of LOLER includes the duties of the competent person making the examination in making their report. There are four paragraphs to this regulation.

- (1) *A person making a thorough examination for an employer under regulation 9 shall -*
 - (a) *notify the employer forthwith of any defect in the lifting equipment which in his opinion is or could become a danger to persons;*
 - (b) *as soon as is practicable make a report of the thorough examination in writing authenticated by him or on his behalf by signature or equally secure means and containing the information specified in Schedule 1 to -*
 - (i) *the employer; and*
 - (ii) *any person from whom the equipment has been hired or leased;*

- (c) *where there is in his opinion a defect in the lifting equipment involving an existing or imminent risk of serious injury, send a copy of the report as soon as is practicable to the relevant enforcing authority.*

When an examiner finds an item that is defective he has a duty to inform the user immediately, so that it can be taken out of service by the user. If the defect is such that the equipment poses a serious risk, he must send a copy of his report to the enforcing authority, the ACoP says that this should be sent to arrive within 28 days. The enforcing authority will be the HSE or, in some cases, the Environmental Health Department of the Local Authority. The guidance notes make it clear that this must be done even if there is no intention of the equipment being used again, or if a repair is made immediately. Guidance note 349 says:

‘Competent persons’ reports are a vital diagnostic aid to the safe management of lifting equipment. Defects which are habitually not detected or rectified until the competent persons’ thorough examination are indicative of inadequacies in management systems. A competent person who fails to report a defect, simply because it has been remedied on the spot, is disguising a potentially dangerous situation.’

Again, this is what was required by the older legislation, although the range of equipment covered is broader.

In the case of equipment that does not belong to the user, eg hired equipment, the report of thorough examination must be issued both to the user and the owner of the equipment, eg the hire company.

Although the regulation says the report must be in writing, the guidance notes say:

‘The report should contain the information detailed in Schedule 1 of LOLER and can be provided in writing, electronically or on computer disk but must be in a form which is usable to the employer in fulfilling his or her duties to act on the information it contains.’

- (2) *A person making an inspection for an employer under regulation 9 shall -*
- (a) *notify the employer forthwith of any defect in the lifting equipment which in his opinion is or could become a danger to persons;*
- (b) *as soon as is practicable make a record of the inspection in writing.*

The person making the in-service inspections between the thorough examinations made by the competent person has a similar duty to inform the employer of any defects.

The third paragraph of this regulation gives the duties of the employer who receives a report of defects. So we need not consider this other than to note that they must not use the equipment until the repair has been made, or if a time was allowed for the repair to be made, they must repair it within that time or remove it from service.

Paragraph four explains that ‘the relevant enforcing authority’ to whom the copies of defect reports are to be sent is the authority for the particular premises (HSE for most industrial premises), but in the case of hired equipment it will always be the HSE.

Best Practice

- (1) The competent person must look at the risks involved if the equipment fails and be prepared to recommend taking the equipment out of service.
- (2) Inform the owner of the equipment about any defect that has been found.

- (3) Make out a report as soon as is practicable.
- (4) Where there is in his opinion a defect which involves an imminent risk of serious injury, send a copy of the report to the enforcing authority.

Information to be Contained in a Report of a Thorough Examination

Schedule 1 of LOLER gives a list of 11 matters which are to be addressed in an examination report. As the report has several uses, not all of the information will apply on every occasion. Your company will have its own methods of producing the various types of report that will be necessary, although it is unlikely that they will now use pre-printed forms as may have been used in the past. You should make yourself familiar with these. When making out reports you must be careful to ensure that you give all of the necessary information relevant to the type of examination or test you have carried out. Here we will simply list all of the information as it appears in the Schedule.

1. *The name and address of the employer for whom the thorough examination was made.*
2. *The address of the premises at which the thorough examination was made.*
3. *Particulars sufficient to identify the equipment including where known its date of manufacture.*
4. *The date of the last thorough examination.*
5. *The safe working load of the lifting equipment or (where its safe working load depends on the configuration of the lifting equipment) its safe working load for the last configuration in which it was thoroughly examined.*
6. *In relation to the first thorough examination of lifting equipment after installation or after assembly at a new site or in a new location -*
 - (a) *that it is such thorough examination;*
 - (b) *(if such be the case) that it has been installed correctly and would be safe to operate.*
7. *In relation to a thorough examination of lifting equipment other than a thorough examination to which paragraph 6 relates -*
 - (a) *whether it is a thorough examination -*
 - (i) *within an intervals of 6 months under regulation 9(3)(a)(i);*
 - (ii) *within an interval of 12 months under regulation 9(3)(a)(ii);*
 - (iii) *in accordance with an examination scheme under regulation 9(3)(a)(iii);*

or

 - (iv) *after the occurrence of exceptional circumstances under regulation 9(3)(a)(iv);*
 - (b) *(if such be the case) that the lifting equipment would be safe to operate.*
8. *In relation to every thorough examination of lifting equipment -*
 - (a) *identification of any part found to have a defect which is or could become a danger to persons, and a description of the defect;*

- (b) *particulars of any repair, renewal or alteration required to remedy a defect found to be a danger to persons;*
 - (c) *in the case of a defect which is not yet but could become a danger to persons -*
 - (i) *the time by which it could become such a danger;*
 - (ii) *particulars of any repair, renewal or alteration required to remedy it;*
 - (d) *the latest date by which the next thorough examination must be carried out;*
 - (e) *where the thorough examination included testing, particulars of any test;*
 - (f) *the date of the thorough examination.*
9. *The name, address and qualifications of the person making the report; that he is self-employed or, if employed, the name and address of his employer.*
10. *The name and address of a person signing or authenticating the report on behalf of its author.*
11. *The date of the report.*

We should note that there is a requirement to record 'any' test that may have been made, not just load or proof load tests. This means that the examiner must record such tests as a functional test, a light load test, NDT, etc.

General

Both PUWER and LOLER are published with an Approved Code of Practice (ACoP) and guidance notes. The ACoPs give practical advice on how to comply with the law: if an employer follows the advice then they will be doing enough to comply with the law in respect of those matters on which the Code gives advice. They may use alternative methods to those set out in the Code in order to comply with the law. However, the Code has a special status. If they are prosecuted for a breach of health and safety legislation and it is proved that they did not follow the relevant provisions of the Code, they must show that they complied with the law in some other way or a Court will find them at fault.

The key changes to the older legal requirements arising from LOLER are as follows:

- (1) The range of equipment regarded as lifting equipment is much wider.
Unlike the Factories Act and the regulations made under the Act, there are no lists of equipment given. LOLER is written in terms of a lifting operation and anything then used in that operation is caught by the requirements.
- (2) The Regulations apply across all industries, including some not previously regulated.
They will apply to all lifting operations, other than carried out domestically, so catching such places as farms, hospitals and schools, which were previously missed by regulation.
- (3) The requirements for thorough examination are more flexible with the option for fixed maximum periods or written examination schemes.

SIMPLIFIED SUMMARY OF LEGAL REQUIREMENTS

Let us now put all of this together and consider the general requirements that apply to new and in-service lifting equipment.

The detailed requirements of the new Regulations are different in many respects to the older Acts and Regulations they replace. However in terms of effect, they do not alter greatly what has been

required since the Health and Safety at Work etc Act was introduced in 1974. In the context of lifting equipment, they require:

- (1) The equipment must be safe and suitable for its intended purpose.
- (2) Manufacturers and suppliers must provide information on the safe use of their equipment.
- (3) Those obtaining equipment for others to use must ensure it is safe and suitable for the intended purpose, and that it complies with the relevant directives.
- (4) The personnel who use the equipment must be suitably trained.
- (5) The equipment must be maintained in a safe condition.
- (6) Records of conformity, test and examination etc must be kept.

The following briefly summarises the above requirements and explains how they are met in practice.

(1) Making Equipment That is Safe And Suitable

Manufacturers must comply with the 'Essential Safety Requirements' given in the Machinery Directive. They must identify the hazards associated with the product and eliminate them or reduce the risks to an acceptable level. To show this has been done and that it is safe for its intended purpose, the manufacturer must affix the CE marking to the equipment and issue an EC Declaration of Conformity, both of which signify full compliance with the requirements of the Machinery Directive.

In practice new equipment is always verified in some way, occasionally by a proof load/force test, but also by calculation, visual examination, sample break tests and non-destructive methods.

It should be noted that if a user produces an item of lifting equipment for his own use, eg a spreader beam, he has the same responsibility as an outside manufacturer and must comply fully with the requirements of the Supply of Machinery (Safety) Regulations. If he sends the equipment out for testing prior to use, all he can expect is a report of the test results for his technical file. It is he and not the testing organisation that is responsible for affixing the CE marking and issuing the EC Declaration of Conformity.

(2) Providing Information For Use

Manufacturers and suppliers must provide the purchaser with information on the care and safe use of the equipment. This information should warn of any foreseeable risks and contain details of practices to avoid.

(3) Providing Equipment That Is Safe And Suitable

Employers, or other persons obtaining or providing equipment for persons to use at work, must ensure that the equipment they provide is safe and suitable for the intended purpose. For new equipment they must ensure that it complies with all of the relevant European Directives. Older equipment, first provided before the Directives came into force, should comply with the general requirements of the Health and Safety at Work etc Act and any relevant current Regulations.

(4) Training And Use

Employers are obliged to ensure that equipment is properly used and that operatives are suitably trained in the use of that equipment. Employees are equally obliged to use only equipment for which they have received training/instruction and to use it in the manner in which they have been trained. This is usually achieved by laying down safe systems of work, instruction and training programmes based on generally accepted practices and the manufacturer's/supplier's information. Often such information and training needs to be tailored to the particular industry or site.

(5) Maintenance

There is a general requirement to maintain all equipment provided for use at work and this is of particular importance for lifting equipment. This ongoing obligation is usually met by the introduction of regular maintenance programmes and the details of these being recorded. When repairs affect load-bearing parts, the equipment should be re-verified before further use, if replacements parts are uncertified this will usually be by means of a proof load/force test.

In addition, a responsible person should carry out a check before each period of use to ensure that no damage or deterioration has occurred. Operatives should have a set procedure to withdraw and report any equipment that has suffered damage during use.

Finally, all lifting equipment must be thoroughly examined by a competent person throughout its life. LOLER permits a choice of either a maximum fixed period, the period depending on the type of equipment, or an examination scheme drawn up by a competent person.

(6) Records of Conformity, Test And Examination Etc

All lifting equipment should have a 'birth certificate' to show that, when first made available for use, it complied with the relevant requirements, ie those in force at the time. For new equipment to which the European Directives apply, ie supplied on or after 1 January 1995, this will be an EC Declaration of Conformity. For older equipment it will only be a certificate of test and examination. In many cases it will be the initial report of thorough examination.

The Regulations require that, throughout its life, lifting equipment be subjected to thorough examination by a competent person and the results recorded. Although LOLER permits some flexibility about how frequently this is done, the regulations require the competent person to state on the record the latest date by which the next examination must be made. Within the parameters allowed, the competent person may vary the length of time before the next examination to suit the service conditions. The date stated on the examination record is legally binding on the user.

All records of test, examination, maintenance etc should be retained and cross-referenced for inspection by the HSE, occasionally the competent person may also need to see this. In some circumstances the competent person has a duty to forward a copy of the examination report to the HSE inspector for the district. Test or examination records issued under the previous legislation remain valid under the new Regulations until their normal date of expiry.

DEFINITIONS OF TERMS USED IN THE VARIOUS LEGISLATION

You should make yourself familiar with the terms used in the industry, standards and legislation by reference to Section 1 of LEEA Code of Practice for the Safe Use of Lifting Equipment. Clause 1.2 - Definitions, starts on page 1-2 of the Code and lists all of the commonly used terms. In the introduction we said that the Directives, and therefore the new UK legislation and Harmonised Standards which support the Directive, use some different terms to those traditionally used so we should note them here.

Lifting Accessories/Separate Lifting Accessories

The Directive uses both of these terms, but the definitions given are a little confused. It is generally accepted that these terms have the same general meaning as 'lifting gear'.

Coefficient of Utilisation/Working Coefficient

These terms have the same meaning as 'factor of safety'. They are the ratios applied to establish the WLL and SWL of an item of lifting equipment. Generally the FOS used by the manufacturer

to establish the WLL is referred to as the 'coefficient of utilisation' and the FOS used by the competent person to establish the marked SWL is referred to as the 'working coefficient'.

Test Coefficient

This is the ratio of test load or force applied to an item relative to its WLL.

Static Test

Is a test where a set force is applied to an item of lifting equipment, eg by a test machine. The force applied is determined by use of the appropriate 'test coefficient'.

Dynamic Test

Is a test where a load is applied to a lifting machine and the machine is operated in all of its possible configurations. The load applied is determined by the use of the appropriate 'test coefficient'.

Thorough Examination

A thorough examination is a visual examination of the item, which may include some form of testing, eg NDT, functional test, proof test etc, as is deemed necessary by the person making the examination in order to reach their conclusion as to the safety of the item under examination.

EC Declaration of Conformity

Is a declaration made by the manufacturer, or other responsible person with the legal duties of a manufacturer and who controls the technical file, confirming that the item to which it refers complies fully with the Directive and that the essential safety requirements have been met in full. It must give the following information:

- (a) the business name and full address of -
 - (i) the responsible person; and
 - (ii) where that person is not the manufacturer, eg a importer in the European Union, that of the manufacturer;
- (b) a full description of the equipment, including the make, type and serial number;
- (c) indicate all of the relevant provisions with which the item complies;
- (d) specify the transposed harmonised standards, national standards and technical specifications used; and
- (e) identify the person authorised to sign the declaration of behalf of the responsible person.

EC Declaration of Incorporation

In some cases the responsible person is unable to issue a declaration of conformity, as the item is being supplied in a partially finished state for further work to be done by others, eg an electric hoist for building into a crane may be supplied without its guards, controls or suspension, and cannot therefore function as a machine in its own right until it is finished by others. However the manufacturer still has met the requirements of the Directive, so he is required to issue a Declaration of Incorporation which confirms that the item meets with the relevant safety provisions in as far as it can, but that it cannot function until it is incorporated into another machine or further work has been done. This serves a similar purpose to the declaration of conformity and enables the person who is carrying out the final work to place the document into their technical file to allow them to issue the declaration of conformity for the finished product.

Competent Person

For our studies we need to expand the definition of a competent person given in the Code of Practice for the Safe Use of Lifting Equipment. This term appeared in the older legislation as the requirement for the person making tests or conducting examinations of lifting equipment. Its use

has been continued in the new Regulations, but with a broader meaning. In the new legislation it is used to mean a person competent for the particular duty referred to in the particular regulation. Restricting our considerations to the testing and examination of lifting equipment, we can note that the law does not define a competent person. In real terms only a court of law can decide if a person was competent or not to conduct a test or examination and such decisions can only be made as the result of a prosecution taking place.

Over fifty years ago LEEA, then the Chain Testers' Association, defined a competent person as:
"One who has the requisite knowledge and experience, both theoretical and practical, of the type of material under examination to certify with confidence whether it is free from patent defects and suitable in every way for the duty for which the article is required".

This definition, in one form or another, has subsequently appeared in standards, codes of practice and legislation.

CONCLUSION

It should be noted that the regulations contain further requirements for the thorough examination of lifting equipment for lifting persons. These have not been considered here as they are outside of the scope of the course you are studying.

If you are familiar with the requirements of the older legislation, you will have noted that the practices required by LOLER are the same, or very similar, to those given in the regulations it replaces. Some of the requirements are a little more detailed, whilst others are written in a different style. There are however also some new requirements. As always, you should consult the full Regulations, ACoP and Guidance Notes, published by the HSE in a book entitled 'Safe use of lifting equipment', if you are directly responsible for any of these activities. Your company may have made some changes to the way it deals with reports and you are advised to investigate these so as to be certain you are complying with the requirements.

UNIT NO 1.20

REVISION ASSIGNMENT

We have now reached the concluding unit of Course 1. If you returned the assignments promptly there will be a couple of weeks yet to the examination and this unit will be marked and returned to you before the exam. This will give you some time for revision of the matters you got wrong within your regular revision programme.

If you have not yet started regular revision, now is the time to start. Look through the marked revision assignments and make out a revision programme for yourself based on these. Do not leave revision to the last minute, but spend a little time regularly to go over the work we have covered in the course. This should ensure you have covered all of the content of the syllabus. You may also find it helpful to read through other literature and the relevant British Standards.

Hints on taking the examination

For some of you this may be the first formal examination you have taken, for others it may be many years since you have sat an examination. The following advice is therefore offered so that you are prepared for the experience.

Make sure you arrive at the examination centre in good time. This will give you time to relax following your journey. When you arrive at the examination centre you will be asked to register. You will be allocated a number, this will normally be the same number shown on your letter of admission.

Once you are admitted to the examination room you will find the tables are numbered, find the place which corresponds with your number. The same number should also appear on your question paper and answer book. Check that the question paper is the correct one for the subject you have entered, in this case Part 1. On no account should your name appear on your answer paper, you are known to the examiner only by number.

When the invigilator tells you to commence, look at the instructions. For the Part 1 examinations the question paper is in the form of multi-choice and you will have 1 hour to answer 100 questions. Although this may not sound long it is in fact ample time if you approach it in an ordered manner.

Read the questions through, you will find you know some of the answers immediately, almost like a reflex action, tick the answer of your choice. Do not waste time at this stage on any of which you are not certain or need to think about. This will help you in two ways. Firstly you will find this helps you to settle and acclimatise to examination conditions, secondly your mind will focus and some of the answers will bring other answers to mind.

Some candidates find the early stages of an examination difficult and nerves set in. If you find this happening, relax. Take a minute or two to calm down before returning to the question paper.

Now go back to the start of the question paper looking at those questions which need a little thought or where a simple mental calculation is required. If you want to make notes or write down a calculation do this on the question paper, but make sure you do not write in the answer box. The examiner will only be interested in the box you have put an X against and will ignore

such notes. (Note: If you are completing the assignment electronically, it is not possible to make notes in this way. You should complete the assignment as usual by indicating your answer with the # key).

Your thoughts will now be in full train and you will be surprised how much information comes flooding back. Work through the paper answering those questions you passed over previously. If you find there are still questions you are unable to answer, leave them till later. Finally spend time on those questions that you find difficult, try to recall discussions in the course units or examples in your day-to-day work. Having completed the bulk of the paper previously you will find you now have time to spend giving these questions extra thought. Once you have answered all the questions spend what time you have left checking through. If you find it necessary to make corrections, do this clearly so that the examiner is able to see your choice without confusion. If you are sure you have finished indicate to the invigilator, who will collect your paper and allow you to leave the room. Please do this as quietly as possible so as not to disturb other candidates who may still be working.

It is wise to time yourself and the experience you have gained in completing the revision units is helpful in this respect. Everyone works at a different pace, so no-one can guide you here but you will know how far through the paper is right for you at the halfway mark. The invigilator will normally inform you when you are halfway through the time allowed. If you need to speed up, do so, if you find you have answered nearly all of the questions slow down and give those more difficult questions greater thought. The invigilator will advise you when there are just a few minutes left. Once the allowed time is up he will ask you to stop, do this straight away so you do not run the risk of being disqualified.

The writer hopes you have found the course interesting and a useful aid in your studies.

Good luck with the exams!

The assignment to this unit is in the form of a multi-choice question paper similar to that used in the exam. There are 50 questions and this should take you thirty minutes to answer them all.

The questions in this unit seek to recall the subjects dealt with in all of the previous units and this aligns to the examination syllabus. Please answer ALL of the questions by pencilling an X in the answer box of your choice.

UNIT NO. 1.2

STANDARDS AND CODES OF PRACTICE (Units Used in Rating Lifting Equipment)

As we saw in unit 1.1, the law places duties on manufacturers, suppliers, repairers and hirers of equipment who must meet certain minimum requirements. Legal duties are also imposed on the owners and users of lifting equipment and on those who make the tests and examinations to verify the equipment. The purpose is to ensure that lifting equipment is designed and manufactured to be safe and that it is regularly maintained and examined whilst in service to ensure that it remains safe. The verification of lifting equipment is the duty of the tester and examiner.

The legal requirements tend to be of a general nature, so we need to look further for detailed guidance to assist the tester and examiner in carrying out these duties. Some reference is made in legislation to Standards, Codes of Practice and manufacturers instructions. It is to these that we must refer for further information and guidance. In this unit we will look at standards and codes of practice in a general way and consider how they apply to us in our duties. As well as looking at some of the general requirements they make, we will pay particular attention to the units of measurement they use and which are used in the rating of lifting equipment.

CODES OF PRACTICE

There are various Codes of Practice available to guide the tester and examiner. Some are known as 'Approved Codes of Practice' (ACoP for short). These have a quasi legal status similar to that of the Highway Code - you don't have to comply with them but would be liable to prosecution if you cannot prove that what you did was equal to or better than. Most modern legislation is published with an ACoP, eg LOLER, PUWER etc.

The first legislation dealing with lifting equipment to be published with an ACoP was the Docks Regulations 1988. It reflected the contemporary position adopted by the HSE to many of the previously considered 'grey areas' and led the way forward.

When LOLER was published, the regulations were accompanied by their own ACoP. This makes some changes, altering slightly the working practices from those previously adopted. It is therefore important that you make yourself aware of the ACoP at the earliest possible time as it has some important requirements and guidance for the competent person.

Another type of Code of Practice is the 'Trade or Professional Code of Practice'. These lay down minimum standards and requirements considered necessary by the industry/profession to perform certain duties or practice certain functions in a correct and proper way. Although these have no legal status it is necessary to meet their requirements if you are to be considered competent to carry out certain work. LEEA has such a code, the details of which form the Associations Technical Requirements with which its member organisations must comply. They lay down the minimum requirements for equipment, personnel qualifications and quality systems, which a lifting equipment company must maintain.

The Association carries out regular technical audits of its member organisations to ensure that they are complying with the Technical Requirements in the areas applicable to their scope of work.

The next type of Code of Practice is the 'Recommended Code of Practice'. Again they have no legal status, they are however recommended by the HSE as being a way of meeting certain requirements of the Health and Safety at Work Act or of significantly adding to safety. You could be called upon to prove you were working to such a code or that what you were doing was better than. Here again the LEEA publishes such a code - 'The Code of Practice for the Safe Use of Lifting Equipment'. This is intended for the user of lifting equipment. The individual sections give details of the equipment and standards that apply, guidance on how to select items for certain applications and list the faults and defects which can occur in use. In addition it gives guidance on how the equipment should be correctly used and those bad practices to be avoided. Study of this code is an important element of this course and you should be familiar with its requirements.

Finally there are technical publications and safety information. This covers a wide range of documents and textbooks, from manufacturer's product installation and maintenance manuals through to books covering workshop practices, from product catalogues through to training manuals. Under this heading LEEA publishes a range of training material and indeed this course would fall under this heading. It also publishes a Lifting Equipment User's Pocket Guide, which acts as a quick reference for the slinger and rigger

Another important document published by the LEEA is The Lifting Engineers Handbook. This is intended for the lifting equipment engineer, tester and examiner and you should have a copy. It contains guidance and reference material on which you should be basing your work procedures.

To support its members, LEEA also publish a range of single sheet safety leaflets which are intended to be issued with every item of lifting equipment supplied, as required by both the Health and Safety at Work etc Act and the Supply of Machinery (Safety) Regulations.

You should have your own copies of some of the documents mentioned above . In any event you must have free access to the appropriate documents, particularly the Code of Practice for the Safe Use of Lifting Equipment, to use as a reference in your day to day duties and/or for study purposes.

STANDARDS

British Standards

Of prime concern to the student of this course are British Standards, which give details of specific products. Modern standards are written as safety standards for new products covering, materials, workmanship, design, test and examination requirements. Some standards take the form of recommended Codes of Practice, covering the use, maintenance or application of specific products or the conduct of certain processes.

Product standards take one of two forms, they may be manufacturing standards which detail dimensions, materials and safe working loads, eg BS 4278 - Eyebolts. Alternatively they may be performance standards that offer a range of criteria that the final product must meet, eg BS 2853 - The design and testing of steel overhead runways.

Most of the products with which the student of this course is concerned are covered by British Standards and we will largely limit our later considerations in this course to these. However for the sake of completeness, and as the tester and examiner may be referred to other types of

standard from time to time, we will briefly outline them here to enable us to appreciate their standing.

ISO Standards

ISO (or International Standards) generally take the form of performance standards, which are agreed internationally by a majority vote. Their use is optional but they are often used as the basis for writing national standards. Where the UK accepts these as written, they are published in this country as British Standards. At one time, such standards were given their own BS number (this was known as dual numbering as either number could be specified). A new practice has been adopted in recent years of using the ISO number and adding the prefix BS, for example ISO 2330 - Fork lift trucks - Fork arms - Technical characteristics and testing is published as BS ISO 2330.

In the past, where the UK accepted some, but not all, of the contents of an ISO, a British Standard was published which omitted those parts to which objection was made or amendments were made which added to the requirements. These standards appear only with a BS number and it is necessary to refer to the British Standard catalogue to see the relationship with the International Standard.

If however it was felt that the ISO standard was of no value, contained mainly unacceptable recommendations or demand would not have warranted a British Standard, they were only published as ISO standards in this country. If the tester and examiner is required to work to these standards he is able to check their validity by reference to the BSI Standard catalogue. This details those ISO standards published as British Standards and those BS which are equivalent, but not identical to the ISO (this is also indicated on the cover of the relevant British Standards), and those only published as ISOs.

In more recent times cooperation between the various standards bodies have meant a change is now taking place and we will consider this later.

CEN/CENELEC (Euronorm) Standards

Some years ago it was decided that Europe should have its own standards. CEN and, in the case of electrical equipment CENELEC, were the European Standards bodies made responsible for obtaining agreement between the member states and issuing the standards which were known as Euronorms. At one time in this country these were treated for publication in the same way as ISO Standards. Those accepted by the UK were published as dual numbered British Standards, which have both BS and Euronorm (EN) numbers. Those Euronorms, which the UK did not accept, were simply published with the EN number.

With the advent of the Single European Market (European Union) it is necessary for goods to be able to pass freely throughout the member states. This means that an item made and tested in this country must be accepted in any of the other countries of the Union as complying with their standards and legal requirements. Equally a product from another Member State must be accepted here. European Directives (see Unit 1.1) have been introduced to bring common legal requirements for various products but their 'essential safety requirements' tend to be goal setting rather than specific. This means we must have a new system of standards that support the Directives.

To ensure compliance with the Directives, Harmonised European Standards are now prepared by CEN and CENELEC. These EN standards take on a new importance as they have a quasi-legal status. When they are used by a manufacturer they indicate that the product meets the legal 'essential safety requirements' of the Directive. It is mandatory that member states adopt these Harmonised Standards as national standards, without alteration, and that they withdraw any existing or conflicting standards. They are unlike the older standards they are replacing, as they are safety standards rather than product standards and only address the essential safety requirements of the relevant Directive

To become a Harmonised Standard, an EN must be vetted by the European Commission to ensure that it only addresses the essential safety requirements of the relevant Directive. Once approved, its acceptance is published in the Official Journal of the European Union. They are then published in the UK with a BS prefix, ie as a BS EN standard.

Working to Harmonised Standards is one, and the easiest, way for a manufacturer to demonstrate that he is meeting the legal requirements imposed by the Directive, but manufacturers who claim to be working to such standards would be liable to prosecution if they fail to meet them in full. It is the Commissions view that the requirements given in the Directive are the legal minimum until such times that a Harmonised Standard is published, but once a Harmonised Standard is in place its requirements become the legal minimum.

A more recent move is under way to bring standards throughout the world to the same high levels. CEN and ISO are working together with national standard bodies from around the world to bring all of the standards into line. The approach it to follow that taken in Europe, so that manufacturers can use the standards to demonstrate that they are meeting all necessary legal requirements. This family of standards are being published by ISO and additionally as Harmonised Standards by CEN as EN ISO and then by the British Standard Institute as BS EN ISO. Other national standards bodies follow the same format, eg in Germany the standard is published as DIN EN ISO. In this way, no matter which version of the standard is read the requirements are the same.

THE USE OF STANDARDS AND CODES

Testing and Examining

From the above, we can see that reference to current British Standards ensures compliance with accepted ISO standards and Euronorms, and with all Harmonised Standards. The tester and examiner then need normally only concern himself with British Standards.

Note: When dealing with existing equipment it is important that reference is made to the standard, or edition of the standard, to which the equipment was manufactured and this may not be the current British Standard. LEEA document reference 015 Reference Library - British, European and International Standards lists most of the relevant standards, including some which have been withdrawn or declared obsolescent. It is updated on a regular basis. However, it is the duty of the tester and examiner to ensure he is making reference to the correct standard/edition for the product he is testing or examining.

Standards lay down the verification methods, which may include load tests or other tests to be applied, for new items and give the examination rejection and acceptance criteria for them. In the case of tests, it is often left to the tester and examiner to decide how to apply the test and what

the examination procedure should be. Here guidance may be obtained from the LEEA Lifting Engineers Handbook, which gives general details of the various tests available and the information they will reveal, and from the various LEEA correspondence courses texts.

The required accuracy of test machines or applied loads/forces vary from standard to standard depending on the item, age and the source of the standard. LEEA Technical Requirements therefore call for all test machines and load/force measuring equipment to have a minimum accuracy of $\pm 2\%$. This is necessary to fall within the range of accuracy laid down in most of the product standards.

Standards are generally limited to new products, but the bulk of examinations the tester and examiner will be called on to undertake are made on items which are, or have been, in service. The Code of Practice for the Safe Use of Lifting Equipment gives details of the type of defects which can arise in service and which must be taken into account by the examiner in reaching a conclusion as to the fitness for continued use. The acceptance/rejection criterion is then given in other publications, such as the product specific units of this course and the manufacturer's instructions.

Construction

Whilst not foolproof, if an item complies with a British Standard the tester and examiner can be confident that it is of good construction, strength and a suitable material. If the item is marked with the CE mark, the Supply of Machinery (Safety) Regulations state that there is an assumption that the product complies fully with the requirements of the European Directive. This means that it has been produced to a Harmonised Standard, or otherwise meets the Essential Safety Requirements, thereby signifying it meets all of the requirements of the Directive in full. The examiner can check the item's compliance by reference to the 'birth certificate'. Depending on the age of the equipment this may be the EC Declaration of Conformity and/or a test certificate or other verification document such as a report of thorough examination. It is then necessary to carry out dimensional checks and, if necessary, checking that the heat treatment, assembly etc have been carried out correctly and comparing these to the standard or specification.

Marking and Identification

British Standards lay down what marking is necessary, where and how this should be placed, to fully identify the item, its WLL/SWL, grade and ensure traceability to its documentation.

The identification should be unique so that it is clearly identifiable to the correct birth certificate. In some cases standards permit the use of batch numbering. This presents the examiner with something of a problem, for example - if he is carrying out an examination on a site that was supplied with say 100 shackles from the same batch. How does he ensure he has seen them all, or ensure that he has not looked at the same one more than once? LEEA Technical Requirements therefore call for an individual identification mark at the point of sale.

Safe Working Load, Working Load Limit, Proof Load etc

LOLER requires that all lifting equipment be marked with its SWL. Modern standards for lifting equipment give the WLL requirements whilst older standards give those for SWL. In most cases this is the same value and so it does not create too much of a problem. It can be overcome by marking the load without 'SWL' as the prefix, or by marking the working load limit with the prefix 'SWL'. Only in those special cases where equipment is de-rated for safety reasons, so that the SWL is less than the WLL, will re-marking be necessary when the item is put into service.

(See LEEA Code of Practice for the Safe Use of Lifting Equipment for full definitions and an explanation of these terms).

THE CORRECT USE OF METRIC AND IMPERIAL UNITS

Although modern lifting equipment standards are based on the metric system, a few older imperial standards remain current. A vast amount of lifting equipment made to and rated in the imperial system also remains in service. Many users wish to have all of their equipment rated in the same units. For these reasons there is then a need for the tester and examiner to be able to readily convert from one system of units to another. This is also important where test machines are used to apply a force, but the standard refers to units of mass.

Both systems contain many units and divisions of units, which we do not use in the rating, marking and testing of lifting equipment, as their use might be confusing. To avoid confusion we have adopted a limited range of units and use certain conventions in how we express them. When dealing with any aspect of lifting equipment it is necessary that we understand these units and conventions.

METRIC VERSES IMPERIAL

For centuries, in this country we used the imperial system of weights and measures. Thirty to forty years ago the UK started the adoption of the metric system. Although the process is almost complete, at the present time we are faced with a confusing mix of units from both systems and a generation gap exists, with recent school leavers understanding the metric system whilst older people still tend to use and think in imperial units. This mix is reflected in our everyday lives, for example, we pay for petrol by the litre but beer by the pint. It is also likely that you are able to estimate a mile but have difficulty in visualising a kilometre, as this is how our roads are marked (in Ireland the reverse will now be true).

If you left school after 1980 you will probably tend to measure in centimetres (a metric unit which is not used by industry) whilst if you left school several years ago you will still use inches. Although this section of the course is concerned with the units which apply to the rating of lifting equipment, we can see that it is important to understand them even if we are not directly concerned with rating lifting equipment, as they affect us in our daily lives.

The units, which concern us when rating lifting equipment, are those of LENGTH, MASS, FORCE and STRESS. We will therefore look at their use and the conversion from one system to another. You may, however, be asking why bother to change systems? A very brief answer is given as follows:

The imperial system was formed haphazardly and was based originally on non-constant standards, eg the foot being the length of a mans foot (?size 5 or size 9?). This meant that wide variations existed. As technology advanced it became necessary to introduce a fixed base standard, ie a national standard. Even so variations then existed between the actual measures and weights used in one country to another, eg the inch used in America being shorter than the inch used in the UK, albeit the variations are very tiny. This only became a problem when international trade expanded, with precision components from different countries of origin being assembled into a final product. Some international standardisation was therefore needed. Two further factors must also be considered (1) there are no natural units of force, power etc within the imperial system and (2) it is difficult to read very small imperial units accurately.

The metric system uses smaller graduations and therefore it is possible to read smaller dimensions to a greater degree of accuracy. This can be seen if you look at a rule which has metric and imperial graduations. For clarity the smallest division of an inch marked on a rule is usually $1/32$ nd. If you wish to measure $1/64$ th, you must guess the mid point between the divisions. For practical purposes this is not too difficult, but if you wished to measure a smaller division, eg $1/128$ th, the task becomes almost impossible. The metric scale however will be divided to $1/2$ mm, so by estimating the mid point it is possible to measure to $1/4$ mm. Now $1/64$ th of an inch is 0.3969mm, ie 0.1469mm greater than it is reasonably practical to measure in the metric system.

Certain industries have therefore adopted the metric system, either wholly or in part, since those industries first came into being. For example the electrical industry has always used the metric units of power and the aircraft industry the metric units of length. However, as with the imperial system, there were ambiguities in the older metric system as practised from one country to another. To overcome these problems the SYSTEME INTERNATIONAL D'UNITS (international system of units), known as the SI system, was internationally adopted in 1960.

One further factor to justify changing the system is the ease of learning. Not only did the imperial system form haphazardly, but it was also a random system, with no direct relationship between the units, eg 12 inches = 1 foot, 3 feet = 1 yard, 1760 yards = 1 mile etc. The metric system however is a decimal system with a logical progression of 10 between the units, eg 10 millimetres = 1 centimetre, 10 centimetres = 1 decimetre, 10 decimetres = 1 metre etc. The metric system is therefore a simpler system to learn and apply.

EXPRESSING METRIC UNITS

Great care is needed when writing, stamping or marking the names of the metric units, particularly if they are being abbreviated where the same letter may be common to more than one unit. Many of the SI units take their names from historical people associated with the unit. An example of this, which is relevant to the tester and examiner, is the unit of force - the Newton. This takes its name from Sir Isaac Newton due to his early work on gravity.

Where this is the case, the unit is usually written with a capital letter and the abbreviation for the unit is an upper case letter, so we get Newton and its abbreviation N. this applies wherever the abbreviation appears. In other cases the unit is always written with a lower case letter which is also used for its abbreviation. For example, the SI unit of mass is the tonne and its abbreviation is a lower case t. an upper case T is used as the abbreviation for the unit of magnetic flux. Therefore a WLL or SWL should always be shown as xxt and never xxT.

METRIC MULTIPLES AND SUB-MULTIPLES

The metric system uses standard terms for the multiples and sub-multiples of the various base units shown in the table overleaf:

Factor by which unit is multiplied:	Prefix	Symbol
1000000	Mega	M
1000	kilo	k
100	hecto	h
10	deca	da
1	-	-
0.1	deci	d
0.01	centi	c
0.001	milli	m

These terms are then applied to show the multiplication or division of the base unit. For example the GRAM or GRAMME (either spelling is correct) is the base unit of weight in the metric system. Thus it can be seen that 1/10th (0.1) of a gram is known as a decigram and 1000 grams is known as a kilogram.

As with the unit names, the symbols for the divisions and multiples also use upper and lower case letters, eg Mega = M and milli = m. This then leads to some unusual capitalization, eg **MegaNewton = MN**, **millimetre = mm**, **Watt = W**, **kiloWatt = kW**. There are a few exceptions, so some care is needed, but it is important that we use this convention so as to avoid any confusion between the units.

LENGTH

Let us then consider the units we use to measure length.

Although there are several units of length within the imperial system we only use two of them when discussing lifting equipment, as the others are too large. For small items we use the **inch** (abbr. = in or ") and for larger items the **foot** (abbr. = Ft or '). Sub-division of the inch is by fractions based on 1/64 or multiples thereof, so we obtain a progression of 1/64, 1/32, 3/64, 1/16, 5/64, 3/32 etc. Sub-division of the foot is by the inch and there are 12 inches to 1 foot. Plural of inch = inches, plural of foot = feet. It is also true that when machining items which are required to fit or run together we use decimals of an inch to three or four places, but as we are little concerned by such items when dealing with lifting equipment we need not consider them here.

The base unit of length within the SI metric system is the **metre** (m). Industry and standards accept the thousandth (ie 3 decimal places) as the only subdivision, this is known as the **millimetre** (mm). We do not use other multiples or sub-multiples. This is partly to avoid confusion on drawings where the symbol is not commonly shown. If, for any reason, the decimal point is omitted or obscured the dimension will be identical, eg 1250 mm = 1.250 m and would therefore appear as 1250 or 1.250. Other subdivisions are not therefore used for reasons of clarity, as the meaning is obvious by the relative scale of the dimensions.

For precision work and conversion purposes it is often necessary to subdivide the millimetre, these subdivisions are expressed as decimals, eg the conversion **1 inch = 25.4 mm**

Examples:

- (i) 5 inches = $5 \times 25.4 \text{ mm} = 127 \text{ mm}$.
- (ii) 2 ft 7½ inches = $24 + 7\frac{1}{2} = 31\frac{1}{2} \text{ inches} = 31.5 \times 25.4 = 800.1 \text{ mm}$.
- (iii) 27 ft = $27 \times 12 = 324 \text{ inches} = 324 \times 25.4 = 8229.6 \text{ mm}$ OR 8 m 229.6 mm
- (iv) 152 mm = $152 \div 25.4 = 5.98 \text{ inches}$
- (v) 3.048 m = $3048 \text{ mm} \div 25.4 = 120 \text{ inches} = 10 \text{ feet}$

WEIGHT, LOAD, MASS AND FORCE

Mass and Force are concepts that do not exist as such within the imperial system, but tend to be thought of as weight and load. So let us consider these.

Mass

Mass is the amount of matter in a body. The mass of a body remains unchanged irrespective of its position. Within the imperial system this is thought of as weight and the units of weight that are used in association with lifting equipment are the **hundredweight** (cwt) and **ton**. In calculation and when dealing with pressure and stress a further sub-division, the **pound** (lb), is used.

112 lbs = 1 cwt, 20 cwt (2240 lbs) = 1 ton

Just to confuse matters, in North America a unit called the ton (US) or short ton is sometimes used.

1 ton (US) = 2000 pounds = 0.892 tons (UK)

NB - Caution is needed when dealing with items of USA origin, such as federal specification shackles found commonly in use in the oil industry. Although now marked in metric units older equipment was often rated in (US) tons without the 'US' being shown.

The SI basic unit of mass is the gram, but this is much too small for every day use and so the **kilogram** (kg) is used for light measurements whilst the Megagram is used for heavier ones. This too is inconvenient and would lead to confusion, as there would be at least seven digits for even relatively light loads. We therefore give the Megagram (1000000grams or 1000kg) its own name, the **tonne** so:

1000 kg = 1 tonne

Although 2204 lbs = 1 tonne and 2240 lbs = 1 ton, it has been agreed that for practical purposes of conversion 1 ton = 1 tonne and therefore 1 cwt = 50 kg.

NB - The metric tonne and the imperial ton both have the same pronunciation, so where confusion may arise, it is normal to say 'metric tonne' in conversation.

Force

A force is something that moves, or tends to move, the body on which it acts. As we have already said, there is no natural unit of force within the imperial system. As a result old imperial lifting equipment standards refer to loads and proof loads, which are then expressed as weights. If we consider a simple example of a single leg sling of ½ ton WLL, older standards required this to be proof load tested to 1 ton (ie 2 x WLL). This could be achieved by using the sling to lift a weight of 1 ton, however for various reasons we carry out the testing on a test machine. We are therefore

actually applying a force and not a load to the sling and the force applied is the equivalent to the forces exerted by a mass of 1 ton.

This concept is easier understood in the metric system where the SI unit of force is the **Newton (N)**. This is defined as that force which when applied to a body having a mass of one kilogram, gives an acceleration of one metre per second, per second hence:

$$\text{Force (N)} = \text{mass (kg)} \times \text{acceleration (m/s}^2\text{)}.$$

A distinction must then be made between weight and force, as exerted by a test machine for example. 'Weight' is the measure of a particular force due to the action of gravity. Acceleration due to gravity on the earth's surface is 9.806 m/s².

Therefore using the above formula we can see that:

$$1 \text{ kg (mass)} \times 9.806 \text{ m/s}^2 \text{ (acceleration)} = 9.806 \text{ N (force)}.$$

$$\text{For all practical purposes we can consider } 1 \text{ kgf} = 10\text{N}$$

NB - The term kgf signifies 'kilogram force' being a measure of weight but as the numerical value of mass and weight are the same we refer to them simply as kilograms or tonnes etc.

The Newton is too small a unit for every day use in the lifting industry and so we use the **kiloNewton (kN)** and **MegaNewton (MN)**

$$\text{Therefore } 1 \text{ kiloNewton (kN)} = 1000 \text{ N and is equal to } 100 \text{ kg}$$

$$\text{So } 10 \text{ kN} = 1000 \text{ kg} = 1 \text{ tonne}$$

The few Metric standards calling for proof tests therefore require lifting equipment to be subjected to a proof force. If we again consider a single leg chain sling of 500 kg WLL, then this would be subject to a test proof force of 10 kN (ie the equivalent force to 2 x WLL).

STRESS

Stress is the load or force per unit area. In the imperial system the basic unit of stress is the ton per square inch, expressed as **ton/inch²**, or for smaller units pounds per square inch, **lbs/inch²**.

The SI unit for stress is the Newton per square metre, expressed as N/m² and the accepted multiples used are **kN/m²** and **MN/m²**

The accepted conversion factors are

$$1 \text{ ton/inch}^2 = 15.44 \text{ MN/m}^2$$

$$1 \text{ lb/inch}^2 = 6.894 \text{ kN/m}^2$$

$$1 \text{ MN/m}^2 = 1 \text{ N/mm}^2$$

NB - As the concept of force as a unit did not exist in the imperial system, when the metric system was first introduced a transitional unit 'kgf' and its multiple 'tonnef' were initially used. This then resulted in a unit of stress, kilogram force per square millimetre, expressed as a kgf/mm². In practice this was found to be of little benefit, although it was widely used in standards and other technical publications during the 1970's. Its use has been discontinued and reference to it has been removed from newer standards. You may however encounter this in some older publications, eg when discussing the breaking strength of wire ropes, and the following conversion factors should be used.

$$1 \text{ N/mm}^2 = 0.102 \text{ kgf/mm}^2$$

$$1 \text{ ton/inch}^2 = 1.575 \text{ kgf/mm}^2$$

PRACTICAL CONVERSIONS FOR USE IN RATING LIFTING EQUIPMENT

As equipment manufactured to imperial standards may be found in use alongside equipment to metric standards, and as it may be desirable to have all of the equipment in a factory marked with its safe working load in the same units to avoid operative error, standard conversions are used.

The British Standards Institute offered the following guidance with regard to marking SWL (or WLL) when converting from imperial to metric units:

"Safe Working Loads of less than 1000kg should be marked in kilograms to the nearest whole kilogram. SWL's of 1000kg or more should be marked in tonnes. Only one place of decimals should be used except for 1.25t; for integral values of SWL the '0' after the decimal point should be omitted."

This system has certain advantages when converting from imperial to metric units or where a mix of metric and imperial rated equipment exists side by side, as it avoids the possibility of metric markings being confused with tons and hundredweight's. If, by accident, the metric figure after the decimal place is read as cwts, the mistake will always be on the safe side since, in fact, the single decimal figure is always half the equivalent cwts.

The following table gives examples of the conversions; others can then be calculated on the same basis.

Examples of the Conversions:

1 cwt = 50kg	1 Ton = 1 t	1 Ton 11 cwt = 1.5 t
	1 Ton 1 cwt = 1 t	1 Ton 12 cwt = 1.6 t
2 cwt = 100kg	1 Ton 2 cwt = 1.1 t	1 Ton 13 cwt = 1.6 t
	1 Ton 3 cwt = 1.1 t	1 Ton 14 cwt = 1.7 t
5 cwt = 250kg	1 Ton 4 cwt = 1.2 t	1 Ton 15 cwt = 1.7 t
	1 Ton 5 cwt = 1.25 t	1 Ton 16 cwt = 1.8 t
7½ cwt = 375kg	1 Ton 6 cwt = 1.3 t	1 Ton 17 cwt = 1.8 t
	1 Ton 7 cwt = 1.3 t	1 Ton 18 cwt = 1.9 t
10 cwt = 500kg	1 Ton 8 cwt = 1.4 t	1 Ton 19 cwt = 1.9 t
12½ cwt = 625kg	1 Ton 9 cwt = 1.4 t	2 Ton = 2 t
15 cwt = 750kg	1 Ton 10 cwt = 1.5 t	

It will be noted from the table that in the case of, say, 1 ton 3 cwt, the exact conversion would be 1.15t, but as the second decimal place is disregarded, this becomes 1.1 t.

Examples

- (i) ¾ ton = 750 kg.
- (ii) 1 ton 5 cwt = 1.25 t.
- (iii) 4 ton 17 cwt = 4.8 t.

CONCLUSION

In this unit we have noted the units used in association with lifting equipment. We have also seen their relationships and the conversion factors we use when converting from the imperial system to the metric system and vice versa. For the conversion of length we use a factor which gives us an exact conversion, although we normally round this off to a single millimetre decimal place. For weight conversion we use an approximate conversion, which operates on the safe side, so that at no time would we overload a piece of lifting equipment. In everyday life we can use these same approximations to enable us to visualise the quantity or length of an item measured in either system if we are not particularly familiar with that system of measurement.

To help you prepare for the examinations, the Assignment to this unit is in the form of a multi-choice paper, similar to that used in the Part 1 entry examination. This form of questioning enables a wide scope of coverage in a short period of time. Although the questions are typical of those that may be asked in the exam, you will only be asked three or four questions on this subject in the exams.

UNIT NO. 1.3

MATERIALS

In this unit we will turn our attention to the materials which are used in the manufacture of lifting equipment. We will consider their properties and the desirability of their characteristics, together with some typical uses to which they are put.

The material used in the manufacture of lifting equipment must be strong, it must be capable of resisting shock loads, and therefore ductile, and it must be hard to resist wear. Further it must be capable of being easily worked by at least one of the normal processes such as forging, casting or machining and in many cases it must be weldable. The finished product must, as far as possible, also be able to resist corrosion with minimum care.

PROPERTIES

The balance of the chemical and physical properties is important to us as it affects the suitability of the material selected for specific duties. Let us then discuss some of the more important properties.

Strength

This is probably the single most important property. It is defined as 'the ability of a material to resist rupture when a load is applied'.

Loads may be applied in several ways, but examiners will be mainly concerned with the application of pulling or tensile loads. The tensile strength of a material is the highest load applied to a material in the course of a test to destruction divided by the area of the section. Under the imperial system this is measured in tons/inch² and under the metric (SI) system MN/metre².

The stronger a material the smaller the size or section that is required for a given load. The strength of the material selected therefore affects the size and self-weight of the finished product.

Ductility

This is the ability of a material to undergo cold plastic deformation, usually as a result of tension, ie the ability to be drawn. A ductile material will stretch considerably before fracture, and will for that reason exhibit another property known as **Toughness**.

Good ductility is desirable in lifting equipment. If overloaded, a ductile material will show visible signs of deformation before failure takes place. The opposite of ductility and toughness is brittleness.

Brittleness

This is a tendency to fracture without visible plastic deformation. A material that is brittle will tend to fail without warning it is therefore a property that is undesirable in lifting equipment.

Elasticity

This is the ability of a material to return to its original dimensions after the removal of the stress. A piece of rubber is a good example of a material with high elasticity. If the rubber is pulled (stressed) it stretches but, when released, it returns to its original condition. This is also true of

steel up to a certain point, called the 'Elastic Limit', ie the highest stress which can be applied without producing permanent deformation.

Plasticity

This is the ability of a material to retain its new dimensions after the removal of the stress.

A piece of plasticine is a good example of material with high plasticity. If the plasticine is pulled (stressed) it stretches and, when released, remains in this condition. This is also true of steel that has been stressed beyond its elastic limit. Thus a chain which is overloaded becomes 'permanently deformed' or, to put it another way, it has exceeded its elastic limit and become plastic.

In use, no item of lifting equipment should ever exceed its elastic limit, ie when in use it should always be in its elasticity range and not become plastic.

When a piece of material is stretched it will undergo an increase in length or **Elongation**. In the elastic range, this elongation will usually be relatively small for each increment of stress, but when the material becomes plastic, the elongation will be much greater. If the stress on a material is increased, a point will occur when the material fractures; the elongation at this point is usually expressed as a percentage of the original length, eg 30% elongation.

Toughness

This is the ability to withstand bending without fracture and to withstand shatter. It is generally true that a ductile material is a tough one also. Both these properties are important in lifting gear and machines, where suddenly applied loads, ie shock loading, may be placed on the equipment. We may therefore consider toughness to be a measure of a materials ability to resist shock loading and so a material which is not tough will be **Brittle**.

Hardness

This is the ability to resist cutting, abrasion or indentation. A material needs to be hard if, when in use, other items rub over or against it and tend to wear it to a smaller size.

Corrosion Resistance

Materials used in severe conditions need to be able to resist oxide formation, eg 'rust', on their surfaces. This is achieved by using non-ferrous materials and also by the additions of elements, such as chromium, to ordinary steel. Corrosion will weaken lifting gear by reducing its section, and causing pits so giving rise to stress raisers. It also causes moving parts to lock.

The above properties relate in the main to conditions that arise in use. However there is another property we need to consider, Malleability, and this relates to manufacture.

Malleability

This is the capacity to undergo deformation in all directions, usually by cold deformation such as hammering, bending or squeezing. It is therefore the ability to be cold worked.

MATERIALS USED FOR LIFTING EQUIPMENT

Let us now look at those materials that are used for the manufacture of lifting equipment. We can conveniently divide the materials into three main headings, 1) Metals, 2) Polymers, 3) Natural

products. Of these by far the most common group used in association with lifting equipment are the metals. They are therefore the most important for us to study.

Ferrous Metals

Iron (ferrite) based metals, known as ferrous metals, are amongst the most common and readily available metals known to man. Here we need only concern ourselves with the basic forms. 1) Wrought iron, 2) Cast iron, 3) Carbon steel and 4) Alloy steel.

Iron is a pure metal, an element, and is the second most common metal on earth. It is found naturally throughout the world in an oxidized form of reddish brown ore and in this state contains varying amounts of other impurities.

By varying processes of smelting and working, the impurities are almost totally removed. The result being almost pure iron (99%) with the remaining impurities, in the form of slag, running in threads throughout its structure.

Wrought Iron

When iron is worked by hammering and rolling the resulting structure of the metal is fibrous. However manufacturing wrought iron in this way is reliant on the craftsman's skill and wide inconsistency and variation exists in the makeup and therefore characteristics of the finished material.

Good wrought iron has a tensile strength of 340 MN/m^2 or 22 tons/inch^2 and an elongation of 30% at fracture. The structure should be completely fibrous giving a tough and ductile material.

Historically wrought iron was used to produce all items of forged lifting gear and chain due to its ease of working compared to other materials. As technology has advanced other, more suitable and consistent materials have been developed, as have the ways of working them. This resulted in a decline in the use of wrought iron over a period of 50 years so that its use became almost non-existent by the early 1960's. A policy of automatically replacing wrought iron gear with steel gear adopted at that time should mean the tester and examiner will not encounter any wrought iron equipment. However it is always possible that the odd item has escaped. The tester and examiner should therefore be able to identify wrought iron and be aware of the objections to its continued use in order that he may withdraw it from service, justify his actions and offer a more suitable replacement.

Just as the structure of wrought iron is the result of working, so use from day to day will affect the structure. This is known as work hardening. The fibrous structure will breakdown and become partly crystalline, resulting in loss of ductility. A process of heat treatment known as annealing can restore its properties and this must be carried out at regular intervals. Even as recent as 1961, when the last edition of the Factories Act was introduced, it was found necessary to make this heat treatment a legal requirement at six monthly intervals.

In practice the annealing was carried out, often by the user, in a haphazard and uncontrolled way with a wide variation of results. The consistency and the properties of the material could not be relied on. Further, with the introduction of steel products, which do not harden in the same way and so do not require annealing, it became increasingly possible that wrought iron items would be overlooked with disastrous results.

Wrought iron and wrought iron products can be recognised in several ways. Much wrought iron gear and all wrought iron chain was hand forged, as a result the section of the material varies becoming oval at welds. Welding was carried out by the blacksmith heating the material to welding temperature and then hammering it together producing a scarf weld. See Fig 1.

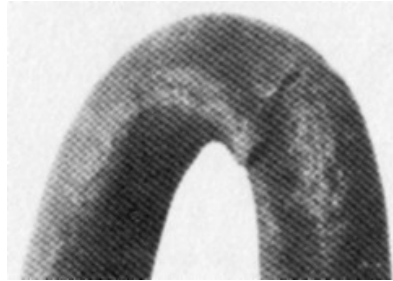

Figure 1

As wrought iron is not as strong as the steels that have replaced it, the general appearance is more bulky. The fibrous nature of the structure is often visible on the surface and is clearly visible when the material is broken. When cut, wrought iron has a dull grey appearance rather than the slightly silver look of steel.

Cast Iron

The tester and examiner is far more likely to encounter cast iron. Although its use is limited, as it is brittle, cast iron still has an important role in the manufacture of certain items of lifting equipment.

Cast iron consists basically of iron, which may be blended with scrap iron or steel to introduce other elements, which mixes with the carbon present. Its melting point is lower than that of steel and, in the molten state, it is very fluid. The basic material may be readily and cheaply melted and then cast in moulds.

Depending on the cooling rate the resulting material will take one of two forms, ie white cast iron or grey cast iron. A high cooling rate results in white cast iron, this is hard, brittle and is un-machinable. A slow cooling rate results in grey cast iron, which is relatively soft, less brittle and is machinable; it is therefore more desirable.

The structure of grey cast iron is a 'steel' like matrix interlaced with coarse graphite flakes which are formed by the carbon present. Whilst the tensile strength of the 'steel matrix' is higher than that of many higher tensile steels, the presence of the graphite flakes results in an overall tensile strength of approximately one fifth (1/5) that of mild steel. The material has very little shock resistance as the graphite flakes, which have no strength, act in the same way as cracks with sharp edges.

Cast iron is however very strong in compression having an average compressive strength of 480 - 510 MN/m² compared to a tensile strength of only 75 MN/m². As the final properties of the finished product are dependant on the cooling rate, it is important that castings used for lifting equipment are of similar thickness throughout, with no sudden changes of section, and that the overall shape kept as simple as possible. In this state cast iron has very limited use in lifting applications. It is only suitable for compressive loads and is therefore only used for some types of jacks and sheaves.

Careful control of the casting process and the introduction of certain alloying elements can make some improvement by modifying the distribution and shape of the graphite. Dependant on the additives and controls, a range of high grade cast iron can be obtained with vast improvements to both compressive and tensile strengths, (typically - compressive 720 - 870 MN/m² and tensile 400 - 530 MN/m²) elongation is also improved. Most common amongst high grade cast irons used for lifting equipment are spheroidal graphite cast iron, in which the graphite takes a nodular form, and high duty inoculated, in which the graphite flakes are refined into fine evenly distributed flakes. These materials have additional uses due to the improved properties and are easily machined. Best known is perhaps an inoculant produced by the meenhanite process. This is often used for trolley wheels, as the distributed graphite also offers some 'self lubricating' properties. See Fig 2.

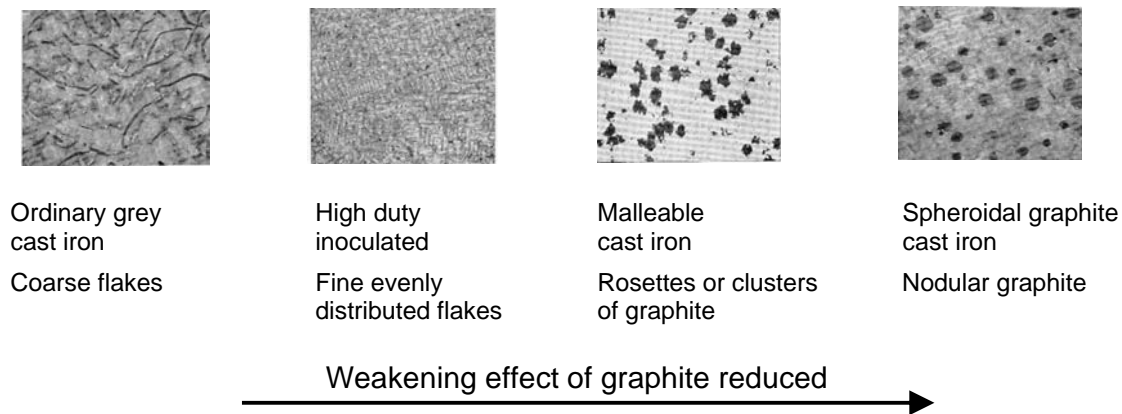

Figure 2

With the exception of the carbon content, which is much higher, the chemical composition of cast iron is very similar to that of mild steel. This makes it suitable for heat treatment. A further refinement can be achieved by annealing white cast iron. This is a lengthy process taking between 40 and 100 hours. The resulting material is known as malleable cast iron. This has an improved ductility and a tensile strength higher than that of other cast irons, but less than that of steel. It can to some degree be cold bent and is more able to resist shock loading. Perhaps its best known use is for steam and gas pipe fittings, but it is occasionally used for minor parts in lifting equipment such as machine casings.

The high carbon content of cast iron makes it a very difficult material to weld and, unless much care and special techniques are employed, welding tends to lead to further cracking.

Steel

Steel is an alloy of iron and carbon, which may then contain other materials, either present as impurities which the manufacturing process has been unable to remove or as added elements included in the manufacturing process to produce the required properties or qualities. The term 'steel' therefore covers a considerable range of materials, each having their own properties.

Steel is normally produced by either the 'open-hearth' process or one of the 'oxygen-blown' processes developed in the early 1950's.

In the open-hearth process up to 100 tonnes of steel can be produced from molten pig iron and steel scrap at a time. The impurities are removed by oxidation, achieved partly by air blown into

the furnace chamber and partly by the addition of high grade oxide ore, forming a slag which can be removed from the surface of the melt.

In the oxygen-blown processes, the impurities are removed from the molten pig iron/steel scrap mixture by immersing a lance and blowing pure oxygen into the melt for a controlled time. This oxidises the impurities, which escape as a gas and form a slag on the surface of the melt; this is removed prior to casting into ingots.

In processing steel, elements not required, such as excess carbon, silicon, manganese, sulphur and phosphorous, are removed by oxidization (ie the elements are made to combine with oxygen). Unfortunately, in this process, it is impossible to prevent the molten iron from partial oxidation.

The presence of oxides in the finished steel can produce a form of brittleness known as strain age embrittlement. If the steel is over-strained followed by resting in warm conditions, the steel may become very brittle. In the course of manufacture (smelting), the addition of such elements as manganese, silicon or aluminium, which attract oxygen, will de-oxidise the steel and produce a steel known as 'killed steel', which is not subject to strain age embrittlement.

When steel sections are manufactured, the steel is first cast into ingots. These are then heated and rolled to produce the required section. Although this is closely controlled, with reliable and consistent results, defects are possible. These usually take the form of cracks, laminations and slag inclusions and are caused by faulty casting or rolling, or by rolling at the wrong temperature.

Carbon Steels

Three classes of carbon steels are used in various ways in the manufacture of lifting equipment. 1) Low carbon steels - having a carbon content of 0.08% to 0.25%, these are known as mild steels, 2) Medium carbon steels - having a carbon content of 0.25% to 0.33%, these are known as higher tensile steels and 3) high carbon steels having a carbon content of 0.33% to 0.6%, these are known as high tensile steels.

As the name suggests the quantity of carbon present affects the tensile strength, the form and distribution of the carbon affecting the mechanical properties. During the end product manufacture the processes used may alter the grain structure, distribution and form of impurities and the form and distribution of the carbon. This results in a change to the properties, sometimes better properties result, but more usually these changes are adverse. We are able to restore and, in some cases, improve the properties by various forms of heat treatment. We will discuss this in the unit devoted to methods of manufacture.

As the use of wrought iron declined, mild steel was used to produce chain and a wide range of fittings. In more recent times, its use has also declined to be commonly replaced with higher tensile steel gear. Today, like wrought iron, mild steel is considered unsuitable for use in the manufacture of lifting gear ie chains and fittings. It is however widely used for fabricated items, such as grabs, trolleys, spreaders and runways. Mild steel chain and fittings are recognisable by a grade mark of 3 or more usually no mark at all, this will be discussed in later units, if found in service they should be replaced with more suitable gear.

Higher tensile steel is used to manufacture chain and fittings. The resulting product is one third (1/3) stronger than that of mild steel and is recognisable by a grade marks 4, 04 or M. Whilst

eyebolts and some shackles are still produced from higher tensile steel, its use has also declined in recent times with alloy steels now being the main material used to manufacture chain and fittings

High tensile, or high carbon steels, have limited use in lifting equipment but their hard wearing properties make them suitable as drive shafts, wheel axles and sheave pins.

Alloy Steels

Alloy steels have varying carbon contents but they obtain their properties from the addition of other alloying elements. Into this group of steels can be placed a carbon steel, which has additional manganese of 1.3% to 1.5% added. This is known as 1.5 manganese steel or 'mangear'. It has high resistance to shock loading and does not suffer from strain age embrittlement. Although placed under this heading its general properties are similar to those of higher tensile steel. It is an ideal material for lifting gear, however in practice its availability is somewhat limited. As a result very little of this material is used for general gear, but some grade 4 shackles are still produced for use in the mining industry.

At one time the most commonly used alloy steel in lifting gear was to an American specification - SAE 8620. In addition to carbon, silicon and manganese, three additional elements are added to the iron to produce this grade of steel, these are nickel, chromium and molybdenum. The resulting steel responds well to varying forms of heat treatment producing chain and fittings that are one third stronger than higher tensile steel. They are hard wearing and have good resistance to corrosion. A range of chain and fittings known as grade 60, or S, are produced from this material, however their availability is now limited. Similar alloy steels, with varying chemical content and heat treated in other ways, are now used to produce the dominant grade 8/T range of chain and fittings. In this condition the chain and fittings are twice as strong as those of higher tensile steel, which they have largely replaced in most general applications.

Steel Castings

Like iron, steel may also be cast. However in its molten state it does not flow as freely as iron. Carbon and alloy steel castings therefore need to be fairly plain in design, as the steel cannot be cast into intricate shapes. By composition control and various heat treatments good results can be obtained. Steel castings were commonly used as case dogs; chain shortening clutches (claws), Bordeaux connections and wire rope thimbles.

Non Ferrous Metals

Non ferrous metals are metals, which contain no iron, or, in some cases, minute amounts either as an alloying element or as an impurity. Most of the non ferrous metals used are in fact alloys, the most common being the copper alloys, although aluminium alloys are becoming increasingly popular for some applications.

Copper and its Alloys

Copper, and low alloy coppers, have a limited use in lifting equipment. Ferrules for use on stainless steel wire ropes and tubing for oil systems are two good examples. Copper is a good electrical conductor; it is used for electric cables, power supply systems and similar electrical purposes.

More common are the two main copper alloys, **Brass** and **Bronze**.

Brass is essentially an alloy of copper and zinc. The range of alloys can contain anything up to 40% zinc to give the desired properties. There are two main groups of **Brass Alloys**, 'cold working' (10%-37% zinc) and 'hot working' (37%-45% zinc). The former group are malleable in the cold state and are suitable for deep drawing. The latter group can only be worked hot. Brass is supplied as castings or wrought (worked) strip. (Tensile strength 200-700MN/m², elongation 15-30%). There is however very little use of brass in lifting equipment.

Bronze is essentially an alloy of copper and tin. The range of alloys can contain anything up to 18% tin to give the desired properties. As with brass, there are two main groups of bronze - wrought tin bronzes (up to 7% tin) generally supplied as rod or strip, and the cast tin bronzes (10-18% tin) supplied as castings. The addition of a small amount of phosphorous (up to 1%) to cast tin bronzes produces a material termed '**phosphorus bronze**'. The effect of phosphorus is to increase the tensile strength and corrosion resistance. It also reduces the coefficient of friction and gives a material suitable for carrying heavy bearing loads.

Although the brass and bronze family of metals are largely used for bearings, they may also be found in other stress bearing forms. Where spark proof or explosion proof equipment is necessary it is not uncommon to use these materials as hooks, shackles and trolley wheels. They may also be found where resistance to corrosion is a consideration, eg load chain pocket wheels and special equipment in chemical plants. In the overall context of lifting equipment however their use is kept to a minimum due to the high cost compared to other materials.

Other alloying elements are often added to bronze to produce a range of materials with varying properties, most common among these alloying elements are aluminium and manganese. Aluminium and manganese bronzes are a range of alloys, which give properties of strength, ductility and corrosion resistance (eg tensile strength up to 770 MN/m²). These metals can be forged and have been used for making chains and fittings where resistance to corrosion is required, eg chemical plant and marine conditions. They are to be found in most modern power hoists where they are used commonly for the manufacture of pocketed load wheels, as their reliability is high and, for this purpose, the production costs are competitive.

Monel Metal

This is an alloy containing approximately 68% nickel and 29% copper with small percentages of manganese and iron. It has good mechanical properties (tensile strength up to 720MN/m² with elongation from 20%-45%) and excellent corrosion resistance.

It can be hot or cold worked, shaped by rolling, forging, pressing or spinning and is easily welded. It is however very expensive and only justifiable in certain situations. At one time it was widely used to produce lifting gear for chemical plants where corrosive conditions are high. However monel metal chain and gear is not now generally available due to cost and the limited application requirements, its use should therefore only be considered where steel gear cannot be used under any circumstances, eg acidic conditions.

Aluminium

This is the most common metal known to man, however in the time scale of technology its existence and uses have only recently become known. It has the property of being light (one third that of steel) and has good corrosion resistance. In the pure form it has poor mechanical properties but there are numerous aluminium alloys with very suitable properties for lifting equipment. At the present time, due to its comparatively recent discovery, the potential of these

alloys has not been fully realised. Typical uses at present are jacks, trolley frames, chain block frames, flat sling eyes and, most notably, for ferrules for wire rope eyes.

Polymers (Plastic)

These are man made; chemical based materials, built up from a series of smaller molecules (basic units) called monomers to form long chain like molecules. These may vary in size from a few hundred to many thousands of basic units. It is these long chains which give polymers their good shock absorption (toughness). The most common polymers have chains that have a backbone of carbon atoms.

Polymers have many useful advantages over metals. They are light, have good electrical and thermal insulation, they can be easily fabricated and cast, they are very resistant to corrosion and have selective resistance to chemicals. Their properties can be considerably altered by addition of additives, ie fillers, plasticisers and stabilisers.

In lifting equipment they are used for ropes, round and web slings, gears, bushes, chain wheels and sheaves. Typical polymers used in lifting equipment are polyamide (nylon), polypropylene and polyester (eg Terylene).

Nylon compounds, often in association with latex and rubber, are also used to manufacture wear seals, pressure seals and oil seals. The tester and examiner will come into contact with these when dealing with jacks and power operated hoists.

Natural Products

At one time the use of natural products was common in the manufacture of lifting equipment. This has declined over the years, largely due to the development of more suitable man-made products. However some natural products are still used, occasionally for load bearing duties, but more commonly for non-load bearing components.

Timber was extensively used in the past for structural duties, eg the members of Derrick Cranes, this is no longer allowed and was specifically prohibited by legislation in the 1960's. Timber is however still used in non-load bearing situations, for example ships pulley block housings and spreaders (not lifting beams) and as wear facing on steel coil lifting hooks and similar items. Its use however is rare nowadays, structural members and load bearing items are usually of steel and plastics and rubbers are used for wear or hard facings.

Natural fibres, produced from grasses and other leaves, spun to form ropes can occasionally be found in use, even so they are largely being replaced with man-made fibre ropes. Although some cotton hand ropes are used on such things as dumb waiters, the tester and examiner is more likely to encounter manila, sisal and hemp. Manila is produced from the leaf of the plantain or wild banana tree and sisal from cactus and hemp from a grass.

Rubber and latex compounds, which are the processed sap of the rubber tree, are sometimes used in association with polymers, to produce seals for hydraulic and pneumatic equipment. Latex and other rubber compounds are used as the tyre treads for such items as mobile gantries and special trolleys, to produce flexible guarding for some items, as soft and wear facings on lifting gear to protect delicate loads and may be found as the insulation on some cables.

Conclusion

In this unit we have looked at the various properties that materials display and noted their desirability in the manufacture of lifting equipment. We have also noted the various materials that are available to us and some of their typical uses. From this we have noted that the majority of lifting gear and most lifting machines are manufactured entirely, or contain a high portion, of steel. As we progress through this course, we will look more closely at the products and consider how we utilize the properties and characteristics of the materials in their manufacture and application.

To help you prepare for the examinations, the Assignment to this unit is in the form of a multi-choice paper, similar to that used in the Part 1 examinations. This form of questioning enables a wide scope of coverage in a short period of time. Although the questions are typical of those that may be asked in the exam, you will only be asked three or four questions on this subject in the exams.

UNIT NO. 1.4

METHODS OF MANUFACTURE

The vast majority of lifting equipment is manufactured from metals and of these; the steels are the most common. In this unit, we will briefly consider manufacturing methods associated with metals, but in particular, the steels. As this working affects the mechanical and physical properties of the metal, we will also consider corrective treatments which are necessary to restore them following working. This treatment is usually by one of the common heat treatment processes, which are used to give properties most suited to the purpose for which the product is intended.

Although the tester and examiner is unlikely to be involved in the manufacture of lifting equipment, it is necessary for him to have a knowledge of the production methods and the faults that can occur in the processing. It is part of the job of the tester and examiner to identify defects and know which faults can be corrected and which render the item unusable.

In the main, our discussions will relate to steel, although most of the processes may also be applied to the other metals. We can group these processes into four basic headings:

- (a) Hot and Cold Working (rolling, drawing and forging)
- (b) Casting (moulding)
- (c) Cutting (flame cutting, sawing, drilling etc)
- (d) Fabrication (welding, bolting and riveting)

HOT AND COLD WORKING

Rolling

In the context of lifting equipment, rolling is a process restricted to the production of prime materials.

Steel is produced by placing the various ingredients into large furnaces and melting them into a single liquid mass. After melting, steel is cast into ingots, which normally weigh one, two or five tonnes. These cool into a solid mass, made up of a crystalline structure. The ingots are then heated to a working temperature, so that they become malleable, and are rolled out to refine the structure.

Refining increases the strength, ductility and toughness of the steel. This results from a breaking down of the coarser 'as cast' crystals of the ingot into much smaller ones by the action of the rollers. In addition, pockets of gas, which became trapped during pouring and that can cause sponginess or blowholes in the ingot, are welded together by the rolling.

Steel sections are produced by further rolling processes and, although other finishing processes are sometimes used, it is rolled steel sections that the tester and examiner will normally encounter. These include plate, flat, round, angle, channel and beam sections. The material can either be finished in the hot rolled state, or for some sections, subjected to a further cold rolling process.

Cold rolling has the effect of giving better dimensional accuracy and surface finish, whilst increasing the strength of the material. It does however reduce toughness and is more expensive to produce.

If a piece of rolled material were examined under a microscope, it would be seen that the crystals have been reduced in size and distorted in the direction of rolling. This has the effect of producing a grain in the material, similar to that found in a piece of wood. Under gradually applied loads, the material is equally strong across and along the grain, but under shock load conditions it is considerably weaker across the grain.

Hot finished steel is generally referred to as '**black**'; it has a scale on the surface, which is an oxidation formed during the rolling process. Cold finished steel is generally referred to as '**bright**', it has a smooth, shiny, surface which is the result of any scale present from earlier rolling being removed during this process, as it has a polishing effect.

All metals may be finished by rolling, but often other processes such as extrusion are used to produce non ferrous sections. A method of extrusion, known as drawing, is also used to produce certain steel sections, such as cold drawn tube and wire. This may be a hot or cold finishing process and the finished product will display similar properties to rolled sections. For our studies here, this process need not concern us. We can just note that the wires used to produce wire rope are made this way.

Although the steel companies have very good quality control and inspection systems, so that very little faulty material ever leaves the works, occasional faults may be found in prime steel. These normally take the form of cracks or laminations, which only become evident during further working processes. They cannot be corrected and the faulty material must be scrapped. This type of fault is often limited to a small area of the overall section and therefore the rest of the original section should be checked and only used if found to be free of fault.

Forging

This is a process which dates back well over 2000 years. Forging ranges from simple hand work, as carried out by the village blacksmith, to the large mechanised forging processes used in mass production or for producing very large components (eg over 100 tonnes).

Many items of lifting equipment are produced by forging, eg hooks, shackles etc.

The main object of forging is to bring the steel, as nearly as possible, to the desired shape and size, ie to produce a finished, or near finished, item. To achieve this the 3 basic process stages are the same, whether for hand or mechanised forging:

- Drawing out - reducing the section thereby increasing the length.
- Swaging - forming of the section between dies.
- Upsetting - increasing the section thickness.

In hand forging, the work is manipulated by the blacksmith with a hammer on an anvil using a few simple tools. The quality of the product is wholly dependent on his skill. For mass production of forged components of the same shape, a process known as '**drop forging**' is employed. Here a piece of material is cut from a standard section, known as a slug. This is heated, preformed, usually a simple bending process, and then formed between a pair of dies bearing an impression of the required object. The lower die is fixed to an anvil whilst the upper die moves under the influence of gravity, or is powered by air or steam. When the two halves of the die meet, the metal is made to flow into all the spaces in the die. Excess material is squeezed out as 'flash', which is later trimmed off. Drop forged components are easily identified by the remains of the flash line around the component.

Small and relatively simple components can usually be drop forged in one set of dies, whereas complicated shapes may require a series of dropforging operations to produce the final shape.

It is also important to ensure that the direction of the grain in the final product gives the maximum toughness. Figure 1 shows the grain flow that would result in a hook stamped directly from a slug of appropriate size. The hook would have an inherent weakness at the bearing points of both the eye and seat of the hook. Figure 2 shows a hook produced from a slug that has been initially bent from bar and then forged. Here the grain flow is seen to follow the shape of the hook.

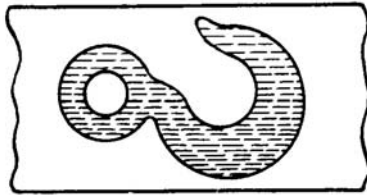

Figure 1

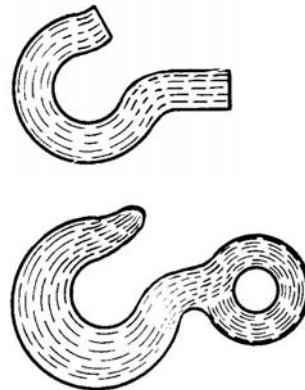

Figure 2

Forging is carried out within a controlled temperature range, eg for mild steel between 1250°C and 900°C. A narrower range applies to higher carbon and alloy steels and is more critical. At the higher temperature material will flow more easily, but the process should not continue below the lower temperature as cracks will develop and the material become too hard and brittle.

It can be seen that the forging process will have affected the grain structure, thereby altering the characteristics and performance of the ‘as forged’ item. Some undesirable hardening will have occurred. Fortunately we are able to soften and toughen the forged item by subsequent heat treatment. We will briefly discuss heat treatment at the end of this unit.

There is nothing that can be done about other faults, which occur in the forging process, or by incorrect handling during heat treatment, the only course is to scrap the forging. In carrying out an examination of forged lifting equipment components, the chief faults to look for are:

- Burning** - where the forged component has been heated for too long at too high a temperature. Oxide penetration of the crystals has taken place, which can be recognised by a glazed appearance.
- Surface cracks** - where the component has been over-stressed in manufacture, particularly on outside bends.
- Deep cracks** - caused by faulty heat treatment, eg too rapid quenching.
- Gall marks** - caused by faulty manipulation of the tools, resulting in a lapping over of the material. If they have been hammered shut, they are difficult to spot.
- Indentations/
cracks and notches**- caused by faulty workmanship, misuse or corrosion.

When an item of lifting equipment is in use it is under stress. It is the designers aim to spread that stress equally throughout the item. If however there are any sharp changes of section in the component, the stress will be concentrated at these points, known as **stress raisers**, and lead to premature failure of the component due to the **notch effect**.

Gall marks, notches, cracks, indentations and sharp internal corners, all act as stress raisers, coupled with the fact that they limit the effective cross section of a component. It is very important that the examiner is constantly on the watch for these stress raisers in all items of lifting equipment and particularly in highly stressed zones, eg crown of a link.

CASTING

Various casting processes are used for ferrous and non-ferrous metals. Cast iron and cast steel are of particular interest to the tester and examiner. These are usually sand cast.

In sand casting, a pattern of the article is made in wood, plastic, or metal. Pressing the pattern half way into each of two boxes of moulding sand, or other suitable material forms a mould, so that when the boxes are brought together, the shape of the complete article is left in the sand. Cores, made of resin bonded sand, enable spaces to be produced in the mould and provision has to be made for pouring and venting the mould.

Although to see the process carried out on the foundry floor looks crude, it requires a great deal of skill to produce a satisfactory casting. As the molten metal is poured into the mould, the air within the mould escapes through the vent holes. Once the casting has cooled sufficiently it is removed from the mould. Excess metal at the pour and vent hole positions has to be removed, usually by grinding.

There are so many variables that can affect the finished casting that, even with high quality control techniques; defective castings still get into service. The main faults are porosity and blowholes, which are normally caused by poor venting of the mould and a consequent build up of gas, some of which becomes trapped in the solidified casting.

Another fault is 'cold shuts' where two molten streams of metal come together in the mould at a temperature insufficient for them to fuse together, but they just lay against each other until under stress they open up.

Care must also be taken where a component of suddenly changing section is produced, since the lighter section will cool quicker, drawing metal from the heavy section area causing sponginess. In the case of cast iron this may also cause areas of white cast iron to be formed, these will be extremely hard and brittle and often result in cracks forming between the 'white' and 'grey' cast metal.

Due to its brittle nature and low tensile strength, cast iron components are only used in non load bearing circumstances, or where they will be subjected to compressive loads, eg jack bodies. Cast steel components are sometimes used for load bearing duties. Although their use in lifting equipment is limited, they will be found commonly in the form of shortening clutches and magnet sling yokes.

Some non-ferrous metals and plastics are 'cast' by a process known as **injection moulding**. A split die with an impression of the required item is manufactured from steel. Molten metal or

plastic is then injected into the die to take on the required shape. This process is commonly used to produce machine casings and similar items.

CUTTING

Metal Cutting in the Cold State

Although cutting immediately suggests sawing, this heading embraces all of the machining and finishing processes in which metal is removed. These processes include **filing, milling, turning, drilling, grinding and lapping.**

The process used will depend on the shape and nature of the product as well as the required surface finish. Whilst a turned finish is adequate for a shackle pin, the ram of a jack would be lapped and polished. The most common fault the tester and examiner will encounter will be dimensional, ie too much or too little metal removed. The following general points should be observed:

- (1) The surface should be smooth, within the limitations of the process used. The tester and examiner should observe various types of finish found on different items of lifting equipment and be familiar with the appearance of well finished items.
- (2) Mating parts must be produced accurately. Dimensional accuracy, within the tolerance allowable for the equipment under examination, should be maintained.
- (3) Screw threads should be clean cut. Judder (either of the tool or work piece during machining) may cause the metal to tear weakening the thread. Incorrect tool settings and depth of cut cause threads to strip, have double starts or incorrect thread profiles to be formed.
- (4) Where a change of section occurs, an ample radius should be provided to avoid stress raisers being set up. The change of section should be smooth with no steps at the change of section.
- (5) Sharp edges should be removed as they can injure users of the equipment.

Flame Cutting

Flame cutting, or gas cutting as it is sometimes called, is used to cut shapes from steel plate. The process is based on the fact that the oxide of steel melts at a lower temperature than steel. Hence, if a spot on the metal is heated by a gas/air mixture so that it melts and then is subjected to a jet of pure oxygen it will rapidly oxidize and be blasted away.

The flame cutting torch initially supplies the gas/air flame for heating and, when cutting is to commence, this flame is cut down and the oxygen jet switched on. This causes a small area of the steel to oxidize and be blown away.

The process is widely used to produce lifting equipment parts and the examiner needs to be aware of possible defects that can arise.

A good operator can maintain an accuracy of plus or minus 0.4 mm, but even then most cut edges will have a slight ripple. Faulty manipulation at the start or finish can cause a groove or roughness. If left, these grooves or ripples can act as stress raisers. They should be removed by careful machining and blended smoothly if the section of the material permits. The practice of filling deep grooves with weld and grinding is not to be used, except for lightly stressed parts, eg it is not to be used in the saddle of a hook either during manufacture or repair.

The speed of operation and heat of the flame will affect the finish. A correctly set flame, travelling at the correct speed, will result in the edge of the cut being 'clean' and square. If the travel is too slow, or the flame too hot, the cut may appear radiused or a 'welded bead' may be formed along the edge. If the flame is travelling too quickly the cut will not be clean, slag will adhere to the underside of the cut and the ripple marks will run diagonally across the cut.

Deep serration's, if they extend only part of the way across the cut surface or if the ripple marks change direction partway through the cut, may be an indication that the plate is cracked or laminated. Careful examination must be made of all items cut from the same plate and if any doubts exist the entire batch should be scrapped.

The intense heat of flame cutting causes a carbon migration at the surface zone affecting a layer up to 0.4 mm deep. This layer should be removed from all highly stressed parts. For a further depth of about 3 mm, the steel will have been overheated resulting in a coarse grain structure that must be modified by heat treatment. The interference caused by flame cutting to the surface will also affect the fatigue strength of the component. Fatigue strength is defined as the ability to resist fracture under cyclic loading. It is good practice to reduce the design stress by 25% compared to similar forged parts to allow for this.

FABRICATION

Under this heading comes the common joining processes, **welding, bolting and riveting**. In the context of modern lifting equipment, welding and bolting are the main methods of joining sections and assembling structures. In the past, riveting was commonly used in the assembly of structures, eg crane bridges, but this has been almost entirely replaced by the other processes. Riveting still has a minor role to play in the assembly of some items of loose lifting gear.

Large structures are usually bolted together, but quite often the substructures are of welded construction. Smaller structures are usually of an all welded construction. Prior to the common use of welding, riveting was necessary and the tester and examiner may still encounter older spreader beams and cranes constructed this way. Some riveting is still used, eg in the assembly of plate clamps, where the alternative of a bolt would be less secure. Welding and riveting are considered to be 'permanent fixing' whereas a bolted joint is termed a 'temporary fixing'.

Bolted joints take one of two forms. They may be intended to allow the parts to move, as in a grab, or to prevent the parts from moving, as in a splice joint. As everybody will be familiar with bolted joints, it is not necessary to discuss them in detail. The tester and examiner must view all bolts critically and ensure they are correctly fitted for the purpose intended, fitted with washers and that nuts are captive by design or the use of an appropriate locking device.

Welding is the main fabrication technique used for lifting equipment manufacture. There are two principles of welding, firstly forge welding where the two ends to be joined are heated to just below their melting point and then pressed or hammered together causing intermolecular attraction at the interface. This was the method used for making wrought iron gear but, with the replacing of that material, the method is now of no real interest to the examiner.

The second principle involves melting the metals and either pressing them together or adding further molten metal so that they fuse together on cooling. Obviously, the welding process disturbs the metallurgical structure. Often it is necessary to correct this by heat-treatment.

A common method of welding for structural purposes is **manual arc welding**. The process involves passing a high current through a coated electrode, causing an electric arc between the electrode and the parent metals to be joined. The arc melts the metal and the point of the electrode that passes droplets to the molten pool of parent metal. The coating on the electrode is a flux, which melts with the point of the electrode, to prevent oxidization and increase the fluidity of the weld pool. The electrode must be carefully chosen to give similar mechanical properties to that of the parent material.

Also commonly used, and increasing in popularity, is **metal inert gas welding (MIG for short)**. This has certain advantages in batch production work or where long weld runs are necessary. An inert gas cloud, commonly CO₂, argon or a mix of these known as argoshield, is formed around the weld area. A filler wire is fed through the centre of the cloud and an arc is formed between the filler and work piece. The wire melts, in the same way as the core of an electrode, and the gas cloud acts in a similar way to the flux coating by preventing oxidization taking place.

The two most common forms of welded joint are the butt joint and the fillet joint. Correct preparation is necessary if a successful weld is to be achieved. For the illustrations in figure 3 a simple 'veed' joint is shown, but the actual preparation will depend on the materials, welding method, type of joint and actual product being manufactured.

Prior to examination of welded joints any residual slag, formed by the flux, must be removed. This may be done by gently tapping with a chipping hammer and wire brushing. It is very brittle and usually comes away cleanly. The presence of stubborn slag at the weld edges may indicate that fusion has not taken place correctly between the parent metal and the filler. Slag pockets on the surface of the filler run should also be viewed critically. When carefully chipped away they may reveal breaks in the weld run or porosity in the weld.

A small bead run of weld will be formed on the back of a butt welded joint, this indicates full penetration, and the edges of the two plates should not be obvious as this would indicate lack of penetration. The weld should rise naturally from the parent metal and there should be no signs of undercutting or lumpiness. Although some splatter is inevitable, it should be loose and able to be brushed away with a wire brush. Excessive splatter or splatter which cannot be brushed off easily is a sign that the weld may be porous. Figure 3 illustrates various weld appearances.

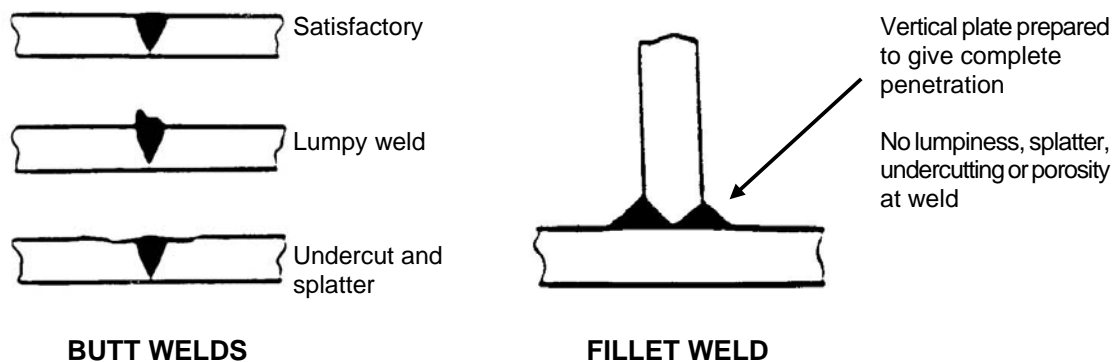

Figure 3

Although the use of welded construction chain slings is declining, there is still a demand for them in certain applications. Various welding methods may be used in the assembly of chain slings; however experience has shown **atomic hydrogen welding** to be the most suitable. An arc is formed between two tungsten rods. Hydrogen is passed over the arc. The hydrogen absorbs the energy of the arc and on striking the work piece this energy is dissipated as intense heat. A cloud is formed surrounding the weld and this prevents oxidization. A filler rod is used to build up the weld which, due to the heat dissipation, has a grain structure akin to that of the parent metal.

In the automatic chain making process a form of welding, known as **resistance welding** is used. In this process an electric current is passed through the two portions of metal to be welded and, due to the combined electrical resistance of the material and the joint, heat is generated which raises the temperature to a welding heat. At this point pressure is applied which causes the two surfaces of the joint to weld. The main form of resistance welding used in chain manufacture is called **flash butt welding**. The two ends are initially held together by light pressure, a current is passed through them generating heat. When the ends are fluid, they are forced together squeezing out oxidized material and producing a consistently sound weld. For standard sizes of chain this is carried out as a continuous process by special machines.

Figure 4 shows two common types of weld produced by resistance welding whilst figure 5 shows how an undercut or deformed weld may appear.

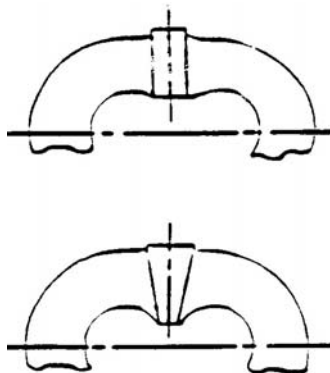

Figure 4

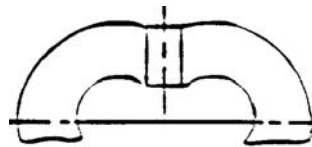

Figure 5

HEAT TREATMENT

Although the majority of testers and examiners in today's industry will not see this being performed in the works, it was common for every test house to have its own furnace until the early 1970's. Some students may remember this. Others may be employed in a works where grade 40 or M chain slings are still made, or where the manufacture of other products necessitates heat treatment, and therefore be familiar with the process. However they may not understand what is happening to the material. For the vast majority of students this will be a process that is only carried out by their company's suppliers, with finished products arriving at their works in the heat treated condition. Some explanations are therefore necessary, as the correctness of this process is vital to the safety and performance of all items of steel lifting gear and many smaller fabrications.

The size, shape and distribution of the grains and impurities, or additives, give steel its various properties. As we have seen, working steel alters these and we need to correct this. For some items and applications we may need to alter them to give the material better properties or

different qualities. They are affected by heat. We can therefore modify them by heat treating the finished components.

For our purposes we do not need a detailed understanding of heat treatment, but only need identify the different processes and understand why we use them. In the course of his duties, the tester and examiner may need to check that an item has been correctly heat treated and so needs a general understanding of the processes involved.

When we work a piece of steel, eg bend, forge, weld etc, we set up stresses between the grains and alter their shape. Heat treatment can be used to relieve those stresses and return the grains to shape, or change the size and structure of the grains. The smaller the grain the stronger, tougher the steel.

At a temperature of approximately 720°, known as the A2 point, carbon present in steel dissolves into the iron in a solid solution. This continues until the iron has absorbed all of the carbon, this point is known as the A3 point. The temperature varies with the carbon content of the particular steel. At the A3 point the grains are small, but if the temperature increases they begin to grow. If this continues for too long the surface grains will melt and the steel will become burnt and unusable.

If the steel is allowed to cool slowly, the grains will remain at the size they attained at the highest temperature, but the carbon will migrate as cooling reaches the A2 point. If the steel is cooled rapidly the grain structure is frozen. In the case of the most rapid cooling, the crystals will be needle shaped and the material will be highly stressed, very hard and brittle and therefore of little practical value.

By re-heating the hardened steel to a lower temperature, we can remove the internal stresses and modify the structure so that small grains remain. The steel will lose some of its hardness and regain a considerable degree of toughness and ductility.

Hardening and Tempering

This is the most common form of heat treatment used to condition lifting equipment today. On completion of manufacture the items are heated to just above the A3 point, where they are held for a time so as to reach a uniform temperature throughout, ie they are allowed to soak. They are then quenched in water, or oil, thus freezing the structure and small grains. This is known as hardening. The item is subsequently reheated to a lower temperature and allowed to cool in still air. This is known as tempering. These operations call for accurate temperature control and timing, which varies with the steel specification, as slight variations considerably affect the final result.

Normalising

When steel is hot worked, eg forged, bent etc, the grain structure is no longer uniform and the material is stressed. We can remove the stress and largely restore the grain structure to its original condition by heating it to just above the A3 point, allowing it to soak and then cool in still air. This is known as normalising and the steel will be very tough and moderately strong. Some standards still permit items to be normalised, although it is rarely used now other than for small mild steel fabrications.

Stress Relieving/Annealing

When steel is cold worked, the grain becomes distorted and the material harder and more brittle. This condition is often referred to as 'work hardening'. It may occur as the result of conditions met in service, but is mainly the result of a manufacturing process. By heating to just below the A2 point for a period of soak and allowing the steel to cool in still air, the condition is corrected. Wrought iron work hardens substantially in service and in the past, when most items of lifting gear were made of wrought iron, periodic annealing was necessary to correct this. However the materials used in the manufacture of lifting equipment now are less affected by this. As a result this process is only used during manufacture to prevent damaging the item. It gives a ductile material, which can be further worked without risk of cracking.

Note Grade 8/T materials are specially hardened and tempered by the manufacturer prior to their supply. Subsequent heat treatment must never be undertaken.

CONCLUSION

In this unit we have noted the common manufacturing processes applied to steel items of lifting gear. The tester and examiner should be able to detect manufacturing faults and identify those that can be corrected by re-working.

To help you prepare for the examinations, the Assignment to this unit is in the form of a multi-choice paper, similar to that used in the Part 1 examinations. This form of questioning enables a wide scope of coverage in a short period of time. Although the questions are typical of those that may be asked in the exam, you will only be asked three or four questions on this subject in the exam. You should note however that this is not an isolated matter and that the subject is related to all steel products. Questions on other subject areas could therefore include an element of the knowledge gained here.

UNIT NO. 1.5

STRESS AND STRAIN IN LIFTING EQUIPMENT

This unit looks at stress and strain in simple terms as they relate to lifting equipment. Although the tester and examiner is not called upon to carry out stress calculations, and indeed he may not be qualified to do so, he does need to have an understanding of their effects on the equipment he is examining and may be testing. Here we look at stress, strain and related matters as they affect lifting equipment and therefore the methods of testing and the safe use.

TENSILE, COMPRESSIVE AND SHEAR FORCES

Figure 1 is a diagrammatic representation of the four basic loading conditions that occur in lifting equipment.

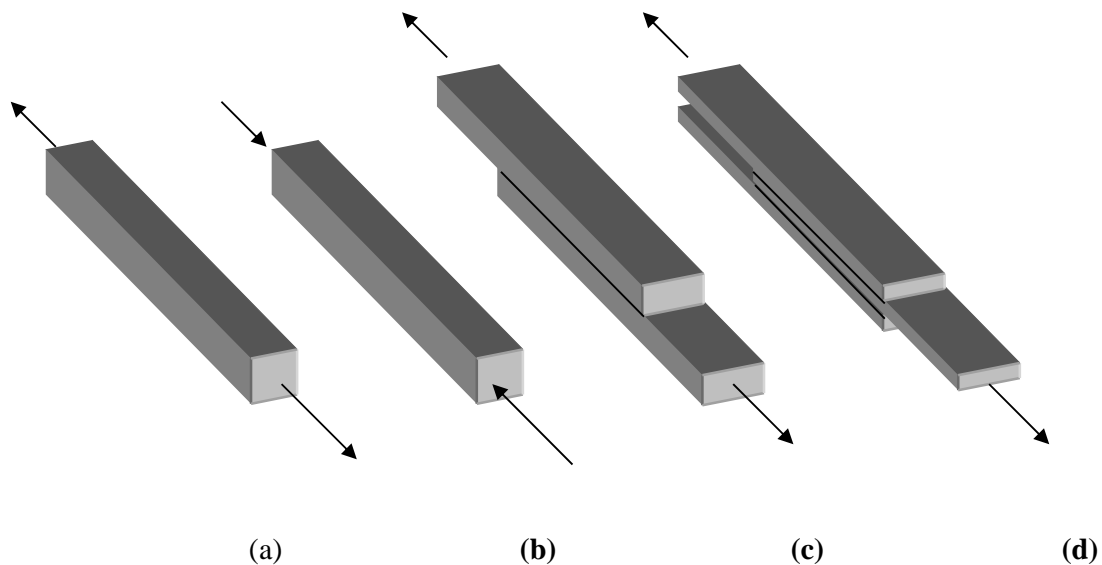

Figure 1

- (a) Shows an item in straight pull, it is in tension and subject to a **tensile load or force**, eg a sling leg under load.
- (b) Shows an item being squeezed, it is in compression and subject to a **compressive load or force**, eg a jack body under load.

When two contacting parts are caused to slide upon each other in opposite directions parallel to their plane of contact by the application of a load they are in shear and subject to a shear load or force.

- (c) Shows an example of **single shear**, eg if two plates are bolted together and subject to a tensile load the bolt would be subjected to the shear stress set up between the two plates.
- (d) Shows an example of **double shear**, eg the pin of a shackle where the load completely fills the jaws is in double shear.

STRESS AND STRAIN

In everyday language stress and strain are synonyms and we often use one to mean the other, but as we will see they are not the same. It is important then that we understand their true meanings and use them correctly when discussing their effects. They are closely related, both being caused by an item being subjected to an applied force.

When an item is subjected to a force the crystals that make up the material resist that force. This cumulative resistance is called **Stress**. We can determine the intensity of stress by dividing the applied load by the cross sectional area of the material thus:

$$\text{Stress} = \frac{\text{Load}}{\text{Cross Sectional Area}} \quad \text{This is Measured in units of } N/mm^2 \text{ or } MN/mm^2$$

The imperial unit of stress is tons/ins².

As the crystals resist the applied force, ie come under stress, the structure deforms. For example if an item of lifting gear lifts a load it comes under tension and it elongates. The relative deformation is called **Strain**. We can determine the strain by dividing the change in length by the original length thus:

$$\text{Strain} = \frac{\text{Change in Length}}{\text{Original Length}} \quad \text{This is a ratio and therefore has no units}$$

TENSILE TEST

When discussing material testing we see that a tensile test reveals a great amount of information from a load extension diagram. From this test it is possible to quantify the important properties of the test specimen. Testers and examiners need to know these properties and how they are determined in order to understand various material specifications and relate these to their suitability for lifting equipment.

A standard test piece of material is subjected to increasing loads applied in a controlled manner. A graph is plotted as the material elongates and eventually fails. The resulting LOAD/EXTENSION diagram is also a diagram of STRESS/STRAIN as the load results in stress and the extension is a measure of the strain.

Five definite points can be seen as the line of the graph is produced. These indicate the positions of the LIMIT OF PROPORTIONALITY, the ELASTIC LIMIT, the YIELD POINT, the TENSILE STRENGTH and the ULTIMATE BREAKING STRESS.

With mild steel samples these points can be clearly seen as the graph starts as a straight line, which then deforms and then takes on a distinctive curve. But with alloy steels they become less distinct as the line tends to be fairly straight. We will therefore limit our considerations to mild steel, although the same is true of all materials.

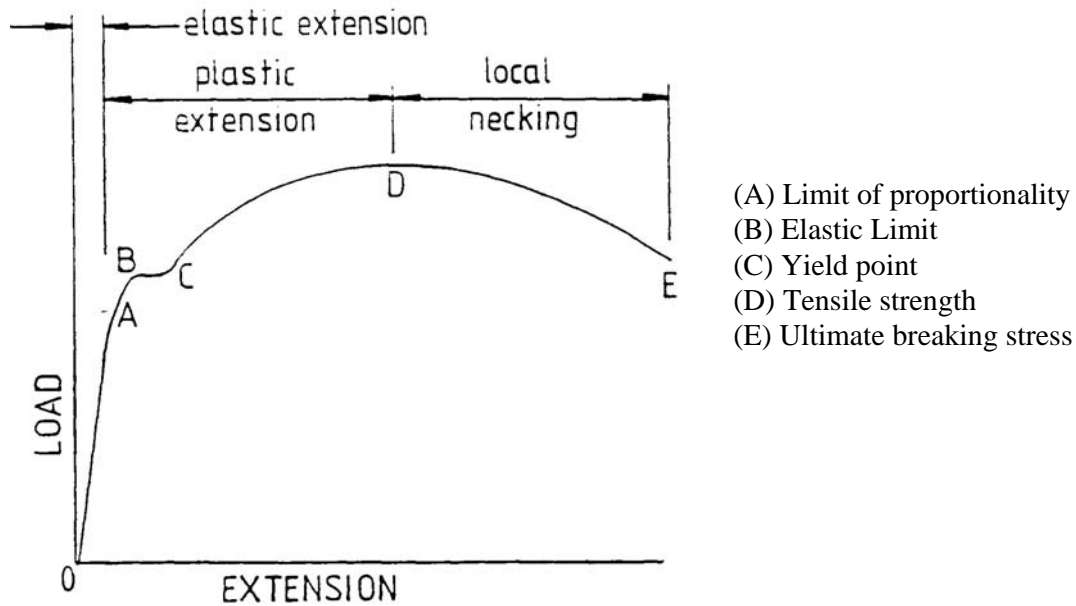

Figure 2

Figure 2 shows a typical graph for a mild steel sample obtained by plotting Load (Stress) against Elongation (Strain):

(A) **Limit of Proportionality.** Initially as the force is applied the Stress and Strain are proportional until we reach point A, this is the point at which our graph is no longer a straight line. This point is known as the Limit of Proportionality.

(B) **The Elastic Limit.** This is the point up to which the material remains elastic. Within the elastic limit the test piece will return to its original dimensions if the load is removed. (With mild steel this point practically corresponds with the Limit of Proportionality, this is not generally true of other materials or for materials that have been overstrained). When this point has been exceeded the extension is permanent and is referred to as **Plastic Deformation.**

(C) **Yield Point.** Slightly above the elastic limit the Yield Point is reached when a sudden permanent extension, B-C, occurs without any increase in load. (Sometimes there is a slight drop in the load, due to the extension, giving an upper and lower yield point).

$$\text{The Yield Point Stress} = \frac{\text{Yield Load}}{\text{Original Cross Sectional Area}}$$

For mild steel this point is fairly easy to locate on the graph but for other materials, eg alloy steels, no such clear-cut point exists.

(D) **Tensile Strength.** The Tensile Strength is reached at this point. When this is passed the cross sectional area becomes noticeably smaller and ‘Necking’ occurs. This is the point of maximum load.

$$\text{Thus Tensile Strength} = \frac{\text{Maximum Load}}{\text{Original Cross Sectional Area}}$$

(E) **Ultimate Breaking Stress.** This is the actual breaking load where an increase in stress is obtained with a reduction in load. Although the value is smaller than the tensile strength this gives a false impression of what actually occurred. From points D to E the section of the test piece considerably reduces as it 'Necks' thereby effectively increasing the stress but as the graph records the stress as load over the original cross sectional area it appears to decrease.

Two other measurements may be determined from the test:

- (1) **The Percentage Elongation.** This is the increase in length divided by the original length expressed as a percentage, ie

$$\% \text{ Elongation} = \frac{\text{Increase in Length}}{\text{Original Length}} \times 100$$

This is a measure of the materials ductility.

- (2) **The Percentage Reduction In Area.** This is the reduction in area at the point of maximum 'Necking' divided by the original cross sectional area expressed as a percentage, ie

$$\% \text{ Reduction in Area} = \frac{\text{Decrease in CSA}}{\text{Original CSA}} \times 100$$

ELASTICITY, HOOKE'S LAW, YOUNG'S MODULUS

Robert Hooke carried out early experiments on simple composition materials. In 1676, during his work on elasticity, he noticed that the applied stress was apparently proportional to the resulting strain up to the elastic limit. His apparatus would be considered crude and inaccurate today and his findings, known as Hooke's Law, like many laws propounded by early scientists are known to be not strictly true. However many materials do show a constant stress/strain relationship as loading is applied, and consequently the term 'Elastic Limit' has to be used with care when referring to the connection between stress and strain. We now know that Hooke's findings are true up to the limit of proportionality, we can therefore say that Hooke's Law states: 'Stress is proportional to Strain up to the Limit of Proportionality'.

$$\text{ie } \frac{\text{Stress}}{\text{Strain}} = A \text{ Constant}$$

This ratio of stress and strain for a material, which shows this straight-line relationship of load extension, is known as **Young's Modulus of Elasticity**, denoted by the symbol E.

$$\text{Hence } E = \frac{\text{Stress}}{\text{Strain}}$$

For mild steel $E = 200,000 \text{ MN/m}^2$. This value gives a relationship of the force to deformation within the elastic range of a material. Therefore the greater the value of E the stiffer the material will be under load.

BENDING STRESSES

Although the tester and examiner will come across many obvious examples of beams, eg spreader beams etc, any item that is supported at one or more positions with a load acting on a part of it, other than at the point of support, can be considered as a beam. Therefore most items of lifting gear when placed under load behave as a beam and are subject to bending stresses. For example the body of a shackle acts as a curved beam whilst the pin acts as a straight beam. In order then that the tester and examiner can determine the positions of maximum stress in items of gear he must have knowledge of the principles of bending.

Figure 3 illustrates the three basic types of beam that are of interest to us.

- (a) The simply supported beam - the beam is mounted on free or flexible supports.
- (b) The encastre beam - the beam is held rigid or by encastred supports.
- (c) The cantilever beam - the beam is held rigid at one end whilst the other end is free.

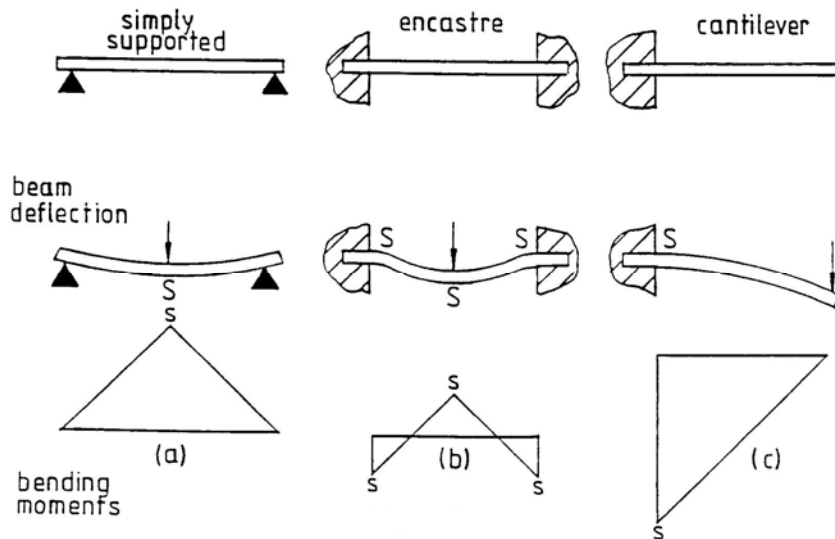

Figure 3

Under load each type of beam will deform in a different way as illustrated by the deflection and bending moment diagrams in Figure 3. Assuming the same material, length and load, the encastre beam will not deflect as much as the simply supported beam but the cantilever beam will deflect by a greater amount than either of the others.

Considering the simply supported beam, Figure 3(a), the applied load will result in stress and strain. The crystals in the lower part of the beam, directly under the load, will be in tension and therefore subject to a tensile stress. The crystals at the top, directly under the load, will be in compression and therefore subject to compressive stress, whilst in the middle of the beam the crystals will not experience any stress.

Hence, the majority of stress is in the outer layers of the beam whilst the centre portion carries little of the stress. It is for this reason that 'I' section beams (eg RSJ and UB) are so popular in structural work, because most of the material is at the positions of maximum stress and the web serves mainly just to keep them in position. Also the deeper a beam, the greater the load it can carry.

The beam will also be subject to shear stress due to the downward load and upward reaction at the supports. This is normally insignificant compared to the other stresses and is only of any consequence on very short thick beams.

We have seen that stress varies across the thickness of the beam. It also varies along the length of the beam. The bending moment diagrams below in Figure 3 show how the stress varies along the length of each beam. From these diagrams we can locate the points of maximum stress in each type of beam. ('S' indicates the position of maximum tensile stress).

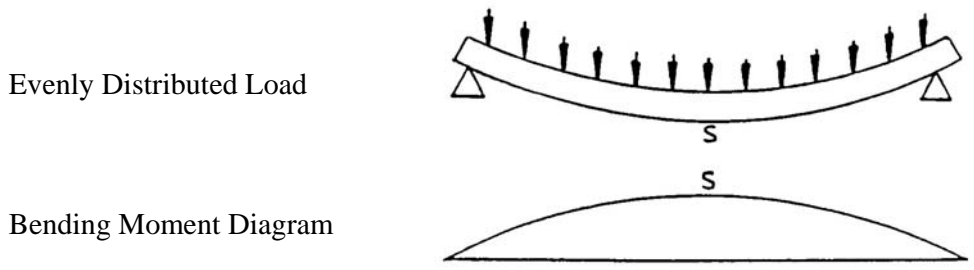

Figure 4

The intensity of the stress along the beam will also depend on how the load is applied. If we consider the simply supported beam in Figure 3(a), it has a single load acting at a point, whereas the same beam in Figure 4 has the load evenly distributed over the whole length.

For the same total load, the position of maximum stress would occur in both at the centre but is only half as great for the evenly distributed load.

To summarise then, the strength of a beam depends upon:

- (a) The shape of the beam section.
- (b) The span of the beam.
- (c) The depth of the beam.
- (d) The mode of load distribution.
- (e) The method of support of the beam.

STRESS CALCULATIONS

The tester and examiner will not be called upon to make stress calculations, nor is it the intention of this course for you to be able to carry out complex stress analysis. Manufacturers employ their own specialists to carry out this work. It is however useful for you to have a knowledge of how to perform simple stress calculations to determine the suitability of a material for a lifting operation.

Stress analysis will usually be in SI units but, at present, Imperial units are still partially in use and so to cover all possibilities, calculations have been performed in both units. Firstly to recap:

$$\text{Stress} = \frac{\text{Load}}{\text{Cross - sectional area}}$$

If Load = P Cross - sectional area = A Then Stress = $\frac{P}{A}$

$$\text{Strain} = \frac{\text{Change in length}}{\text{Original length}} \quad \text{If change in length} = X \quad \text{Original length} = L \quad \text{Then Strain} = \frac{X}{L}$$

$$\text{Young's Modulus of Elasticity} = \frac{\text{Stress}}{\text{Strain}}$$

$$\text{If Young's Modulus of Elasticity} = E \quad \text{Then } E = \frac{\text{Stress}}{\text{Strain}} = \frac{\frac{P}{A}}{\frac{X}{L}} = \frac{PL}{AX}$$

Example (1)

A steel bar 1½" x 1¼" is subjected to a load of 10 tons. Calculate the stress.

$$\begin{aligned} \text{Stress} &= \frac{\text{Load}}{\text{Crosssectional area}} \\ &= \frac{P}{A} = \frac{10}{1.5 \times 1.25} = \frac{10}{\frac{15}{8}} = \frac{10 \times 8}{15} = \frac{80}{15} = 5.33 \text{ tons/inch}^2 \end{aligned}$$

$$\text{Hence Stress} = 5.33 \text{ tons/inch}^2$$

Example (2)

A steel bar 40mm x 30mm is subjected to a load of 100 kiloNewtons. Calculate the stress:

$$\text{Stress} = \frac{P}{A} = \frac{100,000}{40 \times 30} = \frac{100,000}{1,200} = 83.33 \text{ N/mm}^2$$

$$\text{Now } 1 \text{ N/mm}^2 = 1 \text{ MN/m}^2$$

$$\text{Hence Stress} = 83.33 \text{ N/mm}^2 = 83.33 \text{ MN/m}^2$$

Example (3)

If the bar in example (1) is 12" inches long, and Young's Modulus of Elasticity (E) for the material is 13,000 tons/inch², determine the elongation of the bar

$$E = \frac{PL}{Ax} \quad \text{so } x = \frac{PL}{AE}$$

$$x = \frac{10 \times 12}{\frac{15}{8} \times 13,000} = 0.0049 \text{ inches}$$

$$\text{Hence elongation} = 0.0049 \text{ inches.}$$

Example (4)

If the bar in example 2 is 300mm long, and Young's Modulus of Elasticity (E) for the material is 200,00 MN/m², determine the elongation of the bar.

$$E = \frac{PL}{AX} \quad \text{so } X = \frac{PL}{AE}$$

$$X = \frac{100,000 \times 300}{40 \times 30 \times 200,000} = 0.125 \text{ mm}$$

Hence elongation = 0.125 mm

SHEAR STRESS AND STRAIN

The calculations for shear stresses are similar to those for tensile and compressive stresses but the theory and some of the terms are different.

Shear stresses occur due to two or more opposing forces acting in a line offset from each other. Figure 5 shows examples of single shear (a) and double shear (b).

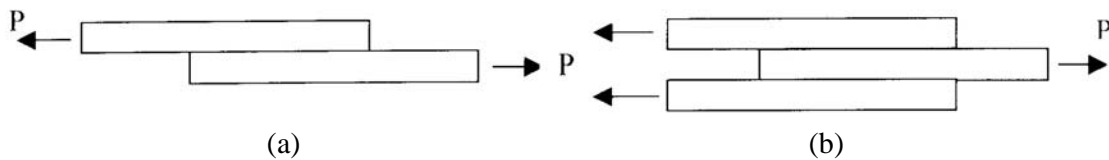

Figure 5

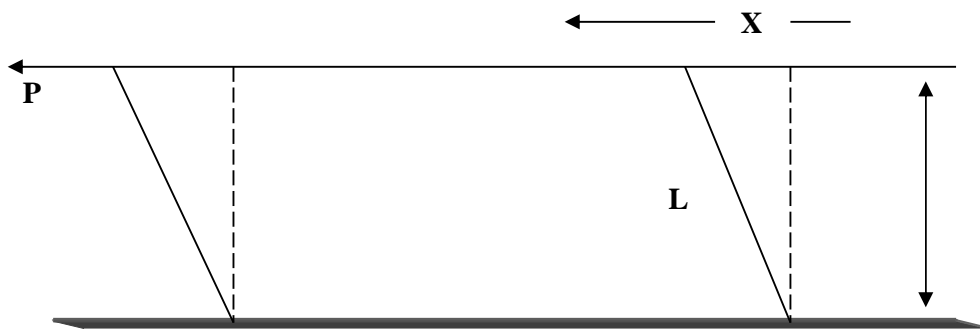

Figure 6
Effect of Shear Force on a Body Secured at its Base

Consider the distortion of a body due to shear forces (Figure 6). Assume that the base is held secure and has a cross sectional area 'A'.

$$\text{Shear Stress} = \frac{\text{Load}}{\text{CrossSectional Area}} \quad \text{Load} = P \quad \text{CrossSectional Area} = A$$

$$\therefore \text{Shear Stress} = \frac{P}{A}$$

$$\text{Shear Strain} = \frac{\text{Distortion}}{\text{An original quantity (in this case length)}}$$

$\text{Distortion} = X$ The original quantity is taken as the length of the Body = L

$$\therefore \text{Shear Strain} = \frac{X}{L}$$

When considering tensile and compressive stresses it was shown that the ratio of stress to strain is constant up to the limit of proportionality. The constant was called the Modulus of Elasticity, ie

$$\frac{\text{Stress}}{\text{Strain}} = \text{Modulus of Elasticity (E)}$$

The same relationship exists when considering shear stress and strains up to the limit of proportionality except this time we call the constant the Modulus of Rigidity (G).

$$\text{Hence } \frac{\text{Shear Stress}}{\text{Shear Strain}} = \text{Modulus of Rigidity}$$

$$\text{Hence } G = \frac{\frac{P}{A}}{\frac{X}{L}} = \frac{PL}{AX} \text{ and } X = \frac{PL}{AG}$$

For mild steel, Modulus of Rigidity is 5,200 ton/ inch², (80,000 MN/ m²)

SHEAR STRESS CALCULATIONS

Example (5)

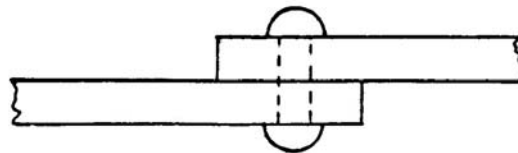

Figure 7

The riveted joint shown in figure 7 is subject to a pull of 2 tons. Calculate the shear stress in the rivet.

$$\text{Area of rivet} = \frac{\pi d^2}{4} = \frac{\pi \times \frac{1}{4} \times \frac{1}{4}}{4} = \frac{\pi}{64} = 0.049 \text{ inch}^2$$

$$\text{Shear Stress} = \frac{\text{Load}}{\text{Crosssectional Area}} = \frac{2}{0.049} = 40.74 \text{ tons/ inch}^2$$

$$\underline{\text{Hence Shear Stress} = 40.74 \text{ tons/ inch}^2}$$

Example (6)

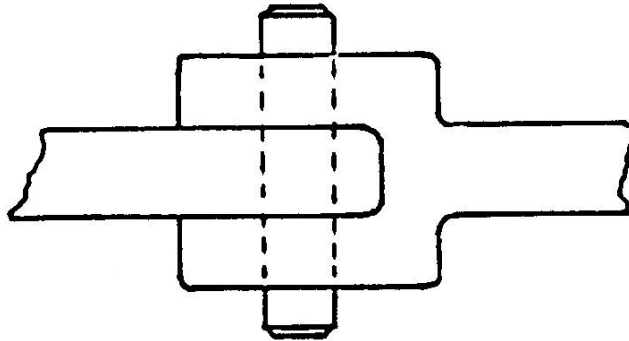

Figure 8

The knuckle joint in Figure 8 is subject to a pull of 10 kiloNewtons. The pin has a diameter of 12mm. Calculate the shear stress in the pin.

$$\text{Area of pin} = \frac{\pi d^2}{4} = \frac{\pi \times 12 \times 12}{4} = 113 \text{ mm}^2$$

$$\text{Shear stress} = \frac{\text{Load}}{\text{Crosssectional area}} = \frac{10,000}{113 \times 2} (\text{Double Shear}) = 44.25 \text{ N/ mm}^2$$

$$\underline{\text{Hence Shear stress} = 44.25 \text{ N/ mm}^2 = 44.25 \text{ MN/ m}^2}$$

Example (7)

A short rectangular cantilever of section 100mm x 40mm projects 90mm from the wall, figure 9. At its end it carries a load of 100,000 N. Take G as 80,000 MN/m². Calculate the deflection at the end due to shear.

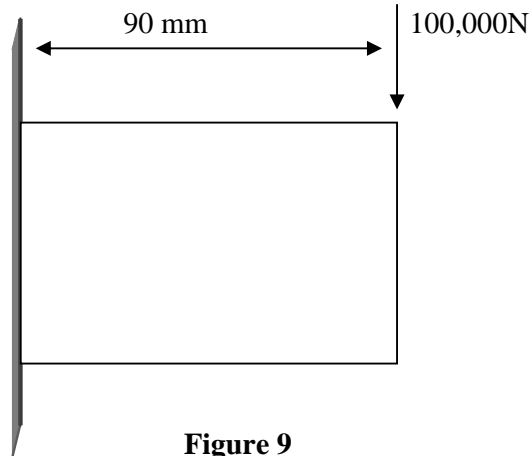

Figure 9

$$G = \frac{PL}{AX} \quad X = \frac{PL}{AG} \quad X = \frac{100,000 \times 90}{100 \times 40 \times 80,000} \quad X = 0.028mm$$

CONCLUSION

Consider the above examples and see how they may be applied to your everyday experiences.

Examples 1 and 2 show items in tension, similar examples can be found in sling legs, Examples 3 and 4 then calculate Young's Modulus of Elasticity for the same item. Example 5 shows a rivet in shear, the calculation for bolts in shear, eg in a runway splice, would be made in the same way. Example 6 has many common examples in lifting gear, the load pin in a Kuplex fitting or a shackle pin. Finally Example 7 would be similar to a jib crane or cantilevered runway beam. You can no doubt find other common examples.

UNIT NO. 1.6

DESTRUCTIVE AND NON-DESTRUCTIVE TESTING

In the context of lifting equipment, the word 'test' often brings to mind a proof load test, which remains one way of verifying certain new equipment and installations. The reasons for this are historical. At a time when a few basic materials were used and lifting equipment was of simple construction, the proof load test was a meaningful way of verifying the construction, strength and suitability of that equipment. As late as the 1960's, legislation was written to include requirements for testing all items of lifting equipment, irrespective of the logic against this, before they were taken into use and this legislation remained in place until 1998.

Advances in technology, materials and process controls brought many changes to the design, standards and reliability of lifting equipment. A very wide range of materials is now used to produce some very complex items. Many of these products do not need to be proof load tested, indeed some may be harmed by such testing, but all lifting equipment needs to be verified in some way. Modern legislation is written to recognise these changes and leaves it to the specific product standards to specify the verification methods to be used or for the tester and examiner to decide in the case of in-service equipment.

There are a lot of different tests available to us. Some are used to ensure that the prime materials are suitable, others to ensure that the processing of that material has been carried out correctly and others to ensure the finished product is both safe and suitable for its intended purpose. In some cases they are also used to monitor in-service equipment to ensure that the service conditions and environments have not affected them. These tests divide into two main groups, destructive tests and non-destructive tests.

Destructive tests result in the item, or a sample taken from the item, being destroyed and therefore rendering it of no further use. These tests are used on prime materials or as type tests on new products. They are also used when investigating an unexpected failure.

Non-destructive tests on the other hand, leave the item in the condition in which it was subjected to testing. These tests may often be used by the tester and examiner in their daily duties or by a manufacturer as a means of quality control.

Proof load testing in fact falls between these two types of test. If the item was satisfactory, no damage will result and the item may enter service, but if the test is successful in revealing faults, the item may well be destroyed by the test. Repetitive testing can also be harmful, as the item is subjected to loads far higher than it was designed to sustain in service, and shortens the useful working life.

The tester and examiner of lifting equipment therefore needs to have an appreciation of the various tests, to understand when they are used and what they tell about the material or product. In this unit we will consider the more common types of test that are employed, either directly by the tester and examiner, or indirectly by the material manufacturer or product manufacturer, in the verification of lifting equipment.

DESTRUCTIVE TESTS

Chemical Analysis

To verify the composition of a material, a chemical analysis is made by an industrial chemist in a laboratory. This is necessary with prime material, to ensure the correct specification has been supplied. It may also be necessary when investigating an accident or unexplained failure to ensure the correct material was used. A small sample of the material is taken for analysis. In the past this was a lengthy process which required a chemist to search for all of the possible elements present and to measure their proportions.

Modern advances in laser technology have made this a much simpler task. Machines have been developed which bounce a laser off the sample. Each element has its own reflective wavelength and affects the laser in a differing way, which like a fingerprint is unique. Measurement of the reflecting beam enables each element to be identified and measured producing a reliable chemical analysis in minutes.

In practice, when we purchase prime material, the results are obtained in the form of a certificate supplied by the steel mill. This relates to the cast from which the bar, plate etc has been rolled. In most cases this is acceptable as confirmation of the correctness of the material.

Having ensured that the correct material is used for the manufacture, it is important that we ensure that the physical properties have been retained during manufacture or restored by subsequent heat treatment. There are several tests that can be made to check these properties. As a rule these are only carried out during research and development, for quality checks by series production companies or when investigating failures. The following tests are usually made by trained metallurgists in controlled conditions and not by the lifting equipment tester and examiner. However it is important that we understand what is involved and the information they give us.

Tensile Test

Strength is probably the most important material property when discussing lifting equipment. We can establish the strength of a material by pulling a sample to destruction in a controlled manner.

Fibre rope, webbing and roundslings are products used in the manufacture of lifting equipment that do not lend themselves to load testing, but it is necessary to ensure that the breaking strength is at least that specified in the relevant standard. Wire rope standards also specify the minimum breaking strength they must attain. Samples are therefore tested to destruction, but the tests are made in the work place using industrial test equipment.

Here we will consider how the metallurgist establishes the tensile strength of a sample of steel in the laboratory. By measuring the load applied and the extension that takes place a graph can be plotted of the stress/strain, from which the following can be determined:

- (a) The tensile strength
- (b) The yield stress (from yield point)
- (c) The ductility (percentage elongation)
- (d) The malleability (percentage reduction in area)
- (e) Young's Modulus of Elasticity
- (f) The breaking point of the material under test

With the exception of (f) the reader will find all the above properties quoted in material specifications as published by British Standards, the steel production companies etc.

The results obtained will to some extent depend on the size, shape and surface finish of the sample. Standardised specimens are therefore used. They are cut and machined from a section taken from the item under test. Details of the standard specimens and methods of test are given in BS EN 10002, which also recommends the rate at which the load is applied, as the faster the rate, the stronger the material will appear.

Figure 1 shows a typical load-extension diagram for a mild steel sample.

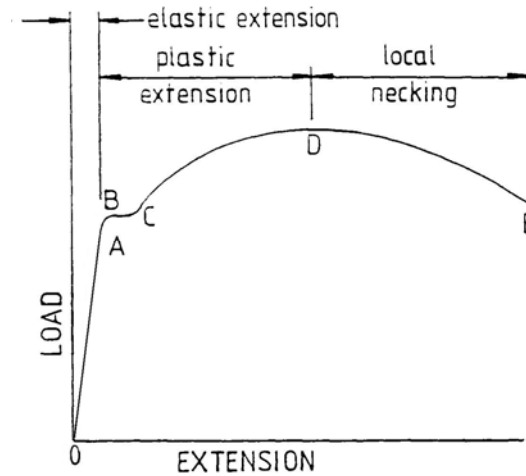

Figure 1

Figure 2 shows the general arrangement of a typical laboratory tensile test machine. It consists of a fixed jaw, which grips one end of the test piece, and a moving jaw that holds the other end. The load is applied by a hydraulic ram and a dial test indicator built into the machine measures the extension.

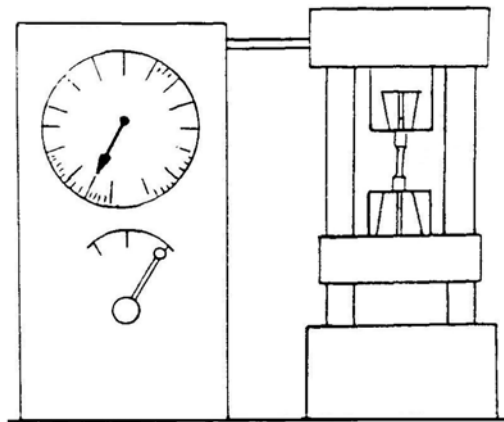

Figure 2

As can be seen, the results of a tensile test tell us much about the material. Typical tensile test results obtained from the three main types of steel used in the manufacture of lifting equipment are given in Table 1.

Typical Tensile Test Results

Material	Tensile Strength	Yield Point	Extension	Young's Modulus
	MN/m ²	MN/m ²	(%)	GN/m ²
Mild Steel	460	245	25	200
Higher Tensile Steel	540	340	22	200
Alloy Steel	770	585	20	200

Table 1

Impact Test

In addition to being strong, lifting equipment needs to be tough and be resistant to brittle fracture under shock load conditions. The metallurgist checks this by using an impact test, which involves a test piece being struck a sudden blow.

There are two main forms of test, the Izod and the Charpy. Both tests involve the same type of measurement but differ in the form of the test pieces. A pendulum is swung down from a specified height to hit the test piece. The height to which the pendulum rises, after striking and breaking the test piece is a measure of the energy used in breaking the sample. If no energy were used, ie the material was very brittle; the pendulum would swing up to the same height that it started from. The greater the energy used in the breaking, the lower the height to which the pendulum rises. Figure 3 shows the general arrangement of a typical impact test machine.

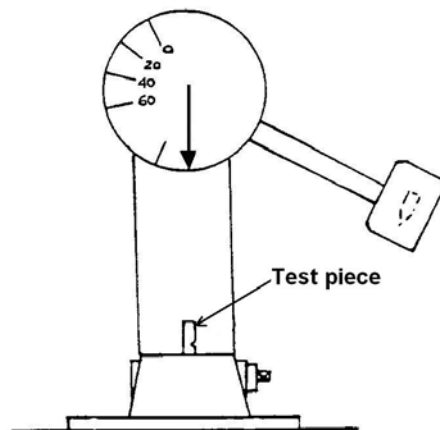

Figure 3

With the Izod test, the energy absorbed in breaking a cantilever test piece is measured in Joules (J) Fig 4(a). The test piece is normally 10mm square, and has a 45° notch. The blow is struck on the same face as the notch and at a fixed height above it. In recent years the Izod test has lost popularity in favour of the Charpy test.

With the Charpy test, the energy absorbed in breaking a beam test piece is measured in Joules (J) Fig 4(b). The test piece is supported at each end and is notched. There are several different forms of this test but here we will consider a 10mm square test piece with a 45° notch. The notch is placed on the face directly opposite to where the pendulum strikes.

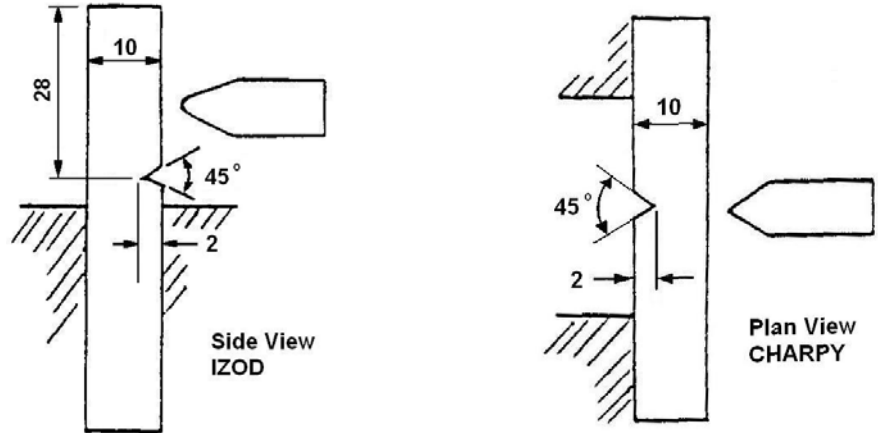

Figure 4

Typical Izod impact test results are given in Table 2. In general, a figure of not less than 50 Joules is desirable in all highly stressed parts of lifting gear.

Typical Izod Test Results

Material	Condition	Izod Impact Value (J)
Mild Steel	Normalised	25 - 40
0.25 - 3% Carbon Steel	Normalised	80
	Hardened and Tempered	90 - 120
1.5% Manganese Steel	Normalised	130
	Hardened and Tempered	100 - 125
Low Alloy Steel	Hardened and Tempered	90 - 120

Table 2

The Notch Effect

Before considering further tests we should make a particular note here of the notch effect as an understanding of this is vital to the tester and examiner of lifting equipment.

In the above tests, the tensile specimen needs to have a good surface finish, ie be free from cuts or notches, whilst a standard notch is deliberately made in the impact specimens. These requirements are necessary to produce reliable standard test pieces that enable scientific comparison of results, whichever test is conducted. You need to be aware of the **notch effect** when testing and examining lifting components, since it will significantly affect the strength.

A notch, or groove, in a component under load concentrates the stress at the root of the notch; that is to say it acts as a **stress raiser**. This results in a deepening of the notch with a consequent increase in stress concentration until finally failure occurs.

A notch will considerably reduce both the tensile and fatigue strength of a component. Sharp corners and changes in section have a similar effect to notches; ie they act as stress raisers and should be avoided by using generous radii or by redesign of the components. It is necessary to machine, or file, out any notches found in lifting equipment before returning the item to service. If this would reduce the component below the minimum allowable thickness it should be scrapped.

Bend Test

Bend tests are a simple test of ductility, which may be conducted in the works. They involve bending a sample of material through some angle, usually 180°, and determining whether the material is unbroken and free from cracks after such a bend.

This type of test is often used to test the ductility of welded joints. Obviously it is not possible or practical to test finished products this way. Welders therefore prepare samples, using specimens of the material prepared and welded in the same way as the actual product. Qualified welders are subjected to regular periodic testing as a part of their approval. A typical bend test is illustrated in Figure 5.

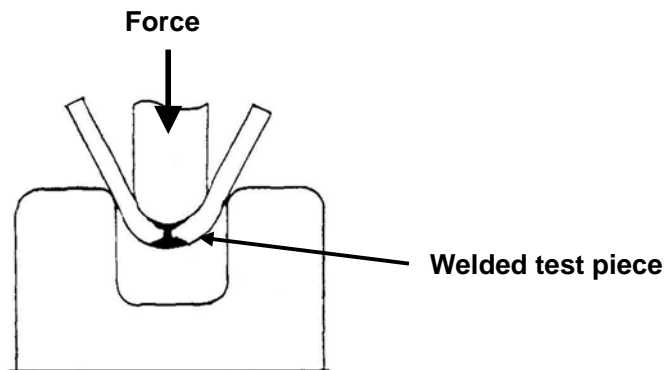

Figure 5

Macro-Examination

Macro-examination is the visual examination of a section of the material or product. This type of test is sometimes made in the works when examining a failed component. Valuable information regarding the cause of failure can often be obtained by a visual examination of the fracture. The presence of slag inclusions, porosity and blowholes can be readily seen in the fractures of welded joints and castings.

Fractures occurring during hot working and casting are often due to coarse columnar crystals forming causing planes of weakness due to casting temperatures being too high. Components, which are subject to reverse stresses or intermittent loading, are subject to fatigue failure. Such fractures can be recognised by two well-defined areas appearing, as shown in figure 6.

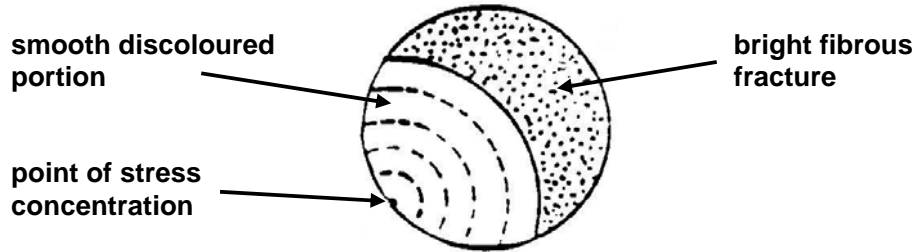

Figure 6

The smooth discoloured area indicates a gradual extension across the section of the crack, usually starting from a notch stress raiser. As a result of the notch effect the stress becomes more concentrated, leading to a gradual extension of the crack. Eventually the remaining material is unable to sustain the load and breaks, usually without warning, showing as a fibrous fracture.

Macro-examination allows a more detailed visual examination to be made. It is particularly useful in revealing the flow lines of the grain in forgings. The grain size can also be seen, as can heat affected zones in welds and flame cut items and the contour of weld deposits. This involves cutting and preparing a section through a sample of the item. The sample is ground with a fine emery cloth, washed to remove any residual grit and etched with an appropriate reagent before being examined by the naked eye or with the aid of a magnifying glass.

Microscopic Examination

Although macro-examination gives us much useful information, far more detailed information can be obtained by microscopic examination performed by a metallurgist. Here the sample is again specially prepared, but now it is highly polished to a fine mirror finish and then viewed under a microscope giving a high magnification. In addition to the information given by a macro-examination hard constituents, eg cementite and non-metallic inclusions can be seen. If the sample is then etched with a suitable reagent the microstructure of the metal may also be viewed.

All of the above tests rely on the destruction of the sample for their results. A further, non-destructive test can be carried out which will give a very good indication that the required physical properties have been attained, providing we know the material and that it is consistent in the way it behaves. This is the hardness test. Other non-destructive tests are also useful in revealing cracks, faulty welds and similar defects. These are of more use to us in our day to day examinations as they leave the item in a serviceable condition if the results are acceptable.

NON-DESTRUCTIVE TESTS

A wide range of non-destructive tests may be used on finished products to ensure that they have been correctly heat treated, are free of surface cracks, blow holes and laminations. Some of these are used by the lifting equipment tester and examiner in his day to day duties whilst others are only used in special cases and require highly trained operatives to interpret the results.

Hardness Test

When conducting a hardness test, we are verifying the results of heat treatment. With lifting equipment we are usually checking standard items, produced to a British Standard using specified materials that give very consistent and known results. If then the tests produce the expected result, not only have we confirmed the heat treatment to be correct and effective, but that the material will also have all of the intended properties. It is then a useful test which, being non-destructive and relatively easily carried out, is used by the tester and examiner in his day to day duties.

Although there are several methods of measuring hardness, the indentation method is used almost universally nowadays. There are three basic methods of indentation hardness testing, the Vickers, Brinell and Rockwell. Of these the Brinell is the most commonly used by the lifting equipment industry. With the Brinell Test (BS EN 10003) a hardened steel ball is pressed into the surface of the material by a standard force. After the load and the ball have been removed, the diameter of the indentation is measured. See figure 7.

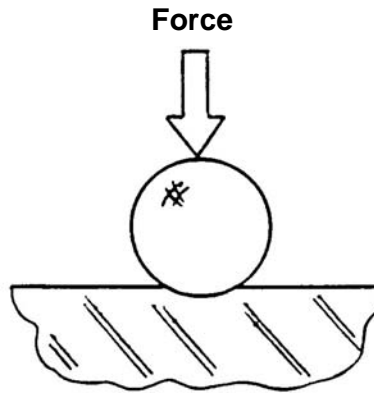

Figure 7

The Brinell hardness number (signified by HB) is obtained by dividing the size of the force applied, by the spherical area of the indentation. This area can be obtained, either by calculation or the use of tables, from the values of the diameter of the ball used and the diameter of the indentation.

$$\text{Brinell Hardness Number } HB = \frac{\text{Applied Force}}{\text{Spherical surface area of indentation}}$$

The Brinell test cannot be used with very soft or very hard materials. In the one case, the indentation becomes equal to the diameter of the ball and in the other case there is either little or no indentation on which measurements can be based. The thickness of the material being tested should be at least ten times the depth of the indentation, if the results are not to be affected by the thickness of the sample.

Typical Brinell hardness values are given in Table 3. The acceptable HB numbers for the various items of lifting equipment are given in the specific product standards.

Typical Brinell Hardness Values

Material	Condition	Hardness Number (HB)
Mild Steel	Normalised	120 - 143
Higher Tensile Steel	Normalised	143 - 193
	Hardened and Tempered	152 - 217
Low Alloy Steel	Hardened and Tempered	248 - 302

Table 3

Liquid Penetration Crack Detection

Various liquid penetration methods of testing can be used to detect fine surface cracks that may otherwise be invisible to the naked eye. These use low viscosity fluids that flow very easily and are able to penetrate the cracks.

Perhaps the best known of these is the dye penetrants. This form of test is widely used by the tester and examiner of lifting equipment when examining welds for defects, or where hairline cracks are suspected.

There are several forms that this test can take, but with a typical example the item under test is coated in a fine liquid dye, often in the form of an aerosol spray. After sufficient time has elapsed for the liquid to penetrate the cracks, the surface is wiped clean of any surplus liquid. A fine, white absorbent powder is then applied which attracts the liquid dye out of the cracks, as blotting paper attracts ink. The dye stains the white coating revealing the cracks as coloured lines.

In some cases hot liquids are applied, the heat causing the cracks to expand so drawing in more liquid as well as making the liquid less viscous. Another form of this test uses fluorescent liquid. The surface is cleaned of surplus liquid and then viewed under an ultra violet light. The liquid in the crack then 'shines' revealing the crack.

Although these tests are very limited, in that they only reveal the position of surface cracks and do not indicate their depth or reveal internal material faults, they are useful in the lifting equipment industry where no cracks are permitted. They may be applied to ferrous and non-ferrous metals.

Magnetic Crack Detection

In this method, the part is magnetised by passing it through a coil or by attaching electrodes and then sprayed with a solution containing iron filings in suspension. A crack or imperfection near the surface of the article will distort the magnetic field and attract the iron filings, drawing them out of solution. The crack is then revealed by an accumulation of particles along the line of the crack.

In this method cracks are only detectable when the lines of magnetic force are significantly at right angles to the crack. Hence if the direction of the cracks are unknown then the component must be tested in two directions each at right angles to each other. Some magnetic crack

detectors only have a single magnetizing coil and hence require rotation of the component during test. Other detectors are fitted with an extra transverse coil and therefore require only one test.

This method of crack detection is restricted to magnetic materials (ie those that can be magnetized). These include the ferromagnetic materials, ie iron and steel, and the non-ferrous materials, nickel, tungsten and cobalt. Ferromagnetic materials are capable of being strongly magnetized. It is important the components are demagnetized after test to prevent them collecting metal particles that can damage bearings etc when in service.

Cracks on the surface or a fissure within about 10mm of the surface can be detected by this method. This type of test is widely used by the tester and examiner when examining components which are susceptible to cracking, eg fork truck arms (tines), which should be routinely examined by this method.

Both of the above methods of crack detection are suitable for shop floor use and are ideal in identifying surface cracks, the main concern when examining lifting equipment. Training in their use is simple and the results are easily interpreted. For deeper faults in materials and welds other methods have to be employed. These require far more training and as a result are usually only used where large, expensive items are suspected of having such faults, as occasional quality checks by series production companies or where an item is to be used in particularly hazardous conditions, eg the nuclear industry. Lifting equipment companies, other than series manufacturers, do not usually make these tests themselves but contract them out to specialist organisations with highly qualified staff capable of interpreting the results. The three most common methods are briefly described below.

Eddy Current Method

If an alternating current is passed through a small coil of wire, then an alternating magnetic field will be produced in the vicinity of that coil. If the coil is near a piece of metal the changing magnetic field causes a current in the metal. This effect is called electromagnetic induction, and the currents induced in the metal are called eddy currents. These eddy currents also produce magnetic fields that interact with those produced by the coil and affect the current flowing in the coil. Providing the metal is consistent, then the current flowing in the coil will remain unchanged whilst the coil is moved over it. If however there is a crack or impurity in the metals, the current in the coil will alter. By monitoring the current in the coil, it is possible to detect flaws in the metal component, which are not patently obvious.

This method is most suitable for thin sections of material and gives best results for materials less than 25mm thickness.

Radiography

In this method, powerful radioactive rays are given off from a source, directed through the article under examination and made to fall on a photographic film, which when developed, gives a picture of the internal structure of the material.

X-rays affect photographic paper in a similar manner to light. The X-rays used are harder than those used in medicine; ie have a shorter wavelength, to give better penetration. They would damage body tissue and hence the equipment must be well shielded to prevent the egress of stray radiation.

As Gamma Rays are harder than X-rays, and are therefore able to attain greater penetration, they are better suited for steel. The source is normally an isotope and extreme care must be taken in use to avoid any human contact with the source.

Radiography will locate a fault in one plane only; ie it will not reveal its depth.

Ultrasonic Testing

In this method, a probe containing a quartz crystal, which can both transmit and receive high-frequency vibrations, is passed over the surface of the material to be tested. The probe signal is amplified and recorded as a waveform on a cathode ray oscilloscope tube. A defect will be revealed as an intermediate echo on the screen, its depth being proportional to horizontal distance. If the fault were perpendicular to the surface of the work (a situation often found when examining welds) then the arrangement shown in Figure 8 would not detect the fault. To find it either of two set-ups may be used:

- (a) The probe can be wiped across the end of the component so that the signal is perpendicular to the fault. This is acceptable providing the length of the job is not excessive and the end is accessible or,
- (b) The probe can be arranged so that the transmitter and receiver are mounted at an angle to the surface (normally 45°).

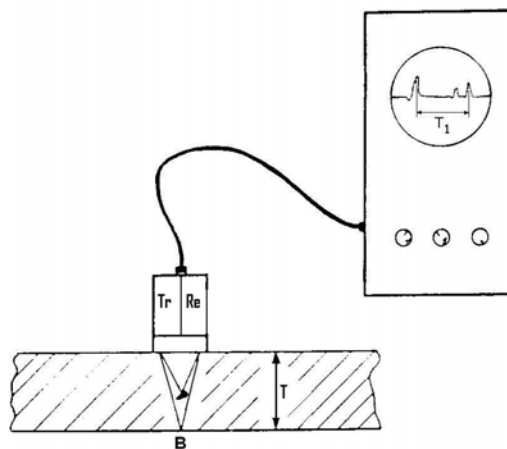

Figure 8

In order to interpret and understand the results of these tests, a full knowledge of the equipment and an understanding of the type of fault to be expected must be had by the operator. This is usually the result of intensive training and in most cases this work is sub-contracted to specialists. The job of the Tester and Examiner is then to assess the report and determine the seriousness of any fault revealed to decide if the item is fit for service, can be reworked and the fault corrected or if the item should be scrapped.

PROOF TESTING

Earlier we said that proof testing was a special case. It can be destructive, resulting in failure of the item under test, or non-destructive, confirming the acceptability of an item. In fact the numbers of failure under proof test are extremely small, due to the high factors of safety associated with lifting equipment. Nevertheless, when carrying out a proof test we must assume

it will result in the item failing and must therefore always take appropriate safety measures. For certain products load destruction tests of a sample are required, eg rope, to establish the minimum-breaking load. In these cases further proof testing will not reveal any additional information and is therefore unnecessary.

There are two forms of proof testing, for small items it is in the form of a tensile force test performed on a test machine. In the case of lifting appliances, proof testing is a dynamic load test where a load is lifted. In either case it is the application of a load, or force, greater than that which the item will meet in service, but which it has been designed to sustain and must be able to withstand whilst remaining serviceable.

The purpose is generally to confirm the suitability of an item for its intended duty and it may reveal defective workmanship, faulty welds or other inherent weaknesses. It is **NOT** a method of determining the working load limit, which can only be done by calculation and tensile tests to destruction, but it does confirm this is set at an acceptable level by revealing deflections and distortions.

Terms Related to Proof Load Tests

Before going further with our studies we will need to clearly understand one or two terms and relate them to the proof load or force. Let us then conclude by noting the following:

Working Load Limit (WLL) This is a feature of design. It is the maximum load that an item is designed to sustain in normal working conditions. Although the actual level at which this is set varies with the complexity of the item and material used, it is within the lower half of the limit of proportionality and as a rule never exceeds 50% of the elastic limit. It is derived from the calculated breaking load to which an appropriate factor of safety is applied.

Safe Working Load (SWL) This is the maximum load an item is permitted to sustain in service and is the load that is marked on the item. (NB It is illegal to exceed the marked safe working load other than in a controlled manner during a test by a Competent Person). The SWL is assessed and set by a Competent Person taking into account the duty and conditions of service to which an item is to be put. In practice this will usually be the same value as the WLL, it can never be greater than the WLL but in cases of severe service, eg a chemical works, it may be lower.

Proof Load or Force This is the load or force which is applied by the Competent Person in a controlled manner for the purpose of conducting a test. Again its level is set dependent on the complexity of the item and material used, but it will be the WLL plus a suitable overload factor. This level should never exceed the elastic limit.

Factor of Safety This is the factor applied to the breaking load of an item to establish the WLL or SWL. Some caution is needed when referring to standards. Modern standards establish WLL's but in older standards the term SWL is used. Where a standard gives SWL it should be read as maximum SWL and in fact means WLL in terms of the above definitions.

Breaking Load This is the point of loading at which an item breaks or deforms to such an extent that it releases the load. For some products, eg wire rope and textile slings, a sample is tested to destruction to ensure that the breaking load meets or exceeds the required minimum breaking

load stated in the appropriate standard. In many of these cases this is the only load test made, as proof tests of the product will not achieve anything further.

Manufacturers Proof Force This is a proof force that the manufacturer applies to the item. In most cases this will be the same as the proof load or force, but with some materials an initial type test greater than the normal proof force is considered necessary. This should never exceed the yield stress and in fact should be just below.

It can be seen from the above that when an item is subjected to the proof load or force very little, or no, permanent distortion of the item should take place. This is quantified in the relevant British Standards and it should be noted that some permit minor deformations whilst others permit none.

Conducting the Test

The proof load, or force, which is applied to a newly manufactured item, is given in the relevant British Standards as a proportion of the WLL. In most cases of lifting gear this is twice the WLL (2.5 for grade 8), manually operated machines WLL + 50% and power operated machines and structures WLL + 25%. Whilst we are fortunate that most items are covered by standards this is not always the case. Where there is no standard, eg lifting beams, we obtain information from the ILO table of formulae which enable the minimum proof load to be calculated.

The method of test is often left to the tester but should, as near as possible, simulate the way in which loads will be applied in service. In the majority of cases the load will act in a straight line through the item and therefore this does not present a problem. However in the remaining cases considerable ingenuity has to be used to devise a method of test that will fulfil this condition, jigs and tooling are often required to meet this need.

Limitations of Proof Testing

It is important to note that proof testing will not necessarily reveal all types of faults present in an item of lifting equipment. As an example, tests on higher tensile steel chain that has only been partially welded have shown that it will withstand the normal proof load without any evidence of deformation. If the outer edges of a link are welded, but the body of the joint remains un-welded, the link will still appear sound to the naked eye, it is unlikely to deform under test and will therefore seem to be acceptable. This situation is not restricted to links and welds, many internal faults, such as cavities and impurities will not be revealed by the test. The competent person then needs to use the thorough visual examination, knowledge and experience of the item and, if deemed necessary, other NDT techniques to assess the suitability of the equipment.

Standards lay down the accuracy of the proof load or force to be applied and where no standard exists the tester must decide what is applicable based on the nature of the item. This varies dependant on the item, age and source of the standard, between $\pm 1\frac{1}{2}\%$ and $\pm 2\%$. The LEEA Code of Practice (Membership) and Technical Requirements lay down certain requirements for test equipment that should be met as minimum requirements:

Test weights must be either calibrated, or used in conjunction with a tensile load cell (eg dynamometer) which is calibrated, so as to ensure an accuracy of $\pm 2\%$ of the applied load. It should however be noted that if in-service cranes (NOT new ones) are to be tested in accordance with BS 7121 the applied load must be within $\pm 1\%$.

Test Machines must be accurate to the requirements of the standard of the product under test, commonly $\pm 1\frac{1}{2}\%$ of the applied load. The requirements for test machine verification are given in BS EN 10002-2, but this classifies machines on the basis of accuracy $\pm 0.5\%$ = Grade 0.5, $\pm 1\%$ = Grade 1, $\pm 2\%$ = Grade 2. It can therefore be seen that the requirement of $\pm 1\frac{1}{2}\%$ falls between Grades 1 & 2. A machine complying with Grade 1 will always be acceptable whereas a machine complying with Grade 2 will only be acceptable if the records show it consistently attains $\pm 1\frac{1}{2}\%$ over its working range.

Test equipment must be checked for accuracy of calibration, verified and adjusted at not greater than yearly intervals. The LEEA, as part of its annual technical audit of members, checks to ensure this is done.

CONCLUSION

Now complete the Assignment to this unit, which again is in the form of a multi-choice paper. This will help you prepare for the examinations, as it is similar to the Part 1 examinations.

UNIT NO. 1.7

VERIFICATION OF LIFTING EQUIPMENT (TESTING AND EXAMINATION)

All lifting equipment must be verified, (a) to ensure it is safe before first use and (b) periodically once it is in service to ensure it remains safe to use. Until the end of the twentieth century all of the various regulations, and therefore the standards, called for lifting equipment to be proof load tested and examined to ensure this was the case, irrespective of the logic for this. Users were then required to retain the 'test certificate and examination reports'. Modern legislation, standards and codes of practice take a more sensible approach. For certain products proof load testing remains a valid test, but for many common items this is not the case and other tests are more meaningful.

Standards give the verification methods for new products, although it is no longer necessary for the user to be given the results of this. For in-service equipment, LOLER places the duty for deciding if, and what, tests may be necessary on the 'competent person' making a thorough examination and requires the details of any tests made to be included on the examination report. (Note the words any test, eg a functional test, a light load test, NDT etc, and not just a proof load test). In this unit we will consider the thorough examination, the general requirements for test equipment used in the examination and look at what tests are available to us.

GENERAL

As we noted in unit 1.1 when we considered the law covering lifting equipment, and which governs our work as testers and examiners, LOLER does not use the word test but refers instead to a thorough examination. The purpose of the examination is to determine if the item being examined is safe to use or otherwise. For many items the examination will be limited to a full visual examination, but for others this will need to be supplemented by any one of a number of tests if the correct conclusion is to be reached.

PREPARING FOR AN EXAMINATION

In all but a few cases lifting accessories and manually operated machines will be readily accessible for examination, unlike a runway or crane where the examination must be made in situ and special procedures would be necessary. We will therefore confine our study to the more basic types of examination that can be made at the bench or in some cases on the floor, although the general principles are the same for all examinations.

The area in which the examination is to be made must be clean and clear of any debris that may hinder the examination or harm the item under examination. It must be well lit, either by natural light or artificial light and free from shadows or tinting, which may impede the visual detection of faults. If, as part of the examination, it is necessary to suspend an item (eg chain block) the suspension point should be at a correct height to enable the examiner to view those parts he is examining with ease. In the case of some items, additional lighting, eg pencil torch or lead light may be necessary, this is particularly the case with suspended machines.

Most examinations are made by the naked eye but for some items the use of magnifying glass, dental mirror or similar visual aid may be necessary.

The item(s) under examination must be clean and free from rust, grease, paint etc, which might obscure defects. Where items require cleaning an appropriate method should be used which will not harm the item. In the case of composite items (eg spreader with top and bottom slings shackled to the beam) and machines these should be stripped down as may be necessary for the examination prior to cleaning, the parts must be clearly identified and kept together.

Examples of cleaning methods are:

- 1) Brushing or wire brushing to remove light rust and debris.
- 2) The use of proprietary solutions to remove stronger rust penetrations. Great care must be exercised here. Many of these products are acid based and whilst dilute acid preparation may be used on some items of lifting gear this is not generally the case. Alloy steels in particular are prone to hydrogen embrittlement when they have been in contact with acid or caustic conditions.
- 3) Shot blasting or rumbling to remove scale.
- 4) Degreasing to remove oils and fats.

Although it is not part of the competent persons duty to carry out the stripping down and rebuilding of equipment, in practice the examiner may find it is necessary for him to do this to some extent. Much will depend on the company he works for, or the conditions that prevail on the site at which he is conducting the examination, and the requirements will vary with the complexity of the item(s) under examination. As part of the preparation he should therefore ensure he has all the necessary tools to hand.

Dimensional checks form part of any examination, the examiner should therefore also ensure he has appropriate measuring instruments, eg rule, micrometer etc, and gauges for the items under examination. For reference purposes he should also have available to him copies of the relevant British or other Standards, drawings or work specifications. Finally he should have the necessary stamps or other appropriate marking devices to enable him to mark, or re-mark, the item with its distinguishing number, SWL and any other necessary information.

CONDUCTING AN EXAMINATION

Correctly identify the item. In the case of a newly manufactured item, where the examination is made following the initial test, check the details against the test record. In the case of an item that has been in service, if there is any doubt as to its identity and/or history, check the previous examination reports and maintenance records as appropriate.

Remember that LOLER leaves it to the discretion of the competent person in deciding if a test is necessary and if so, the nature and form of any such test, in reaching a conclusion as to whether or not the item is safe. The onus as to whether or not the equipment may enter, or return to, service is on the user, not the examiner. The duty of the competent person is only to determine if the equipment is safe to use or not and to report the fact.

The examination must be conducted systematically to ensure all parts are thoroughly examined. In the case of slings or long lengths of chain, rope or wire rope, the examination should start at one end and proceed along the length ensuring all parts are observed, eg remember to turn a chain fully – it has four sides not two. If the examination is interrupted, it should be started again from the beginning to ensure no part is missed.

It is important to remember that permissible amounts of wear, elongation, broken wires etc given in this course, standards, manufacturer's instructions and similar sources are maxima and that a judgement has to be made as to whether the item is fit to continue for a period of service, eg will be safe to operate until the next examination is due, in the particular service conditions.

Carry out dimensional checks against the standard, specification or drawing. Carry out any other checks necessary to ensure the item is in compliance with the standard and/or specification. Carry out a full visual examination. The following gives examples of some typical items and lists the points to be considered during their examination following a period of service. In later units, when we discuss the specific items, we will consider these matters in greater detail.

Chain Slings

Should be examined and checked for:

1. Sizes of chain, links and hooks for loads required
 2. Stretch due to wear and loading (5% maximum), variation in the lengths of the legs; (compare with past records)
 3. Hooks for openings and distortion (see below)
 4. Links and rings for distortion or roundness
 5. Chain for bent and twisted links. The links should articulate freely
6. All parts for wear, (8% reduction in diameter), corrosion, nicks and chemical attack
7. Cracks, weld faults and marks in weld areas

Hooks

Should be examined and checked for:

1. Opening of hook against manufacturer's catalogue, 1/10th maximum (if it exceeds this, scrap hook). Other distortion
2. Wear in eye, saddle etc, ie 8% reduction in thickness
3. Cracks, nicks, scores and gall marks in the body of the hook
4. Shank for alignment, swivel for free running, soundness and completeness of thread etc
5. Corrosion and chemical attack

Shackles

Should be examined and checked for:

1. Sizes for loads to be lifted
2. Correct pin fitted. Free working of pin
3. Wear of the pin thread
4. Alignment of holes in shackle
5. Wear in pin and bow (as per steel chain, ie 8% reduction in diameter)
6. All parts for nicks, cracks, corrosion and chemical attack

Eyebolts

Should be examined and checked for:

1. Size for loads to be carried
2. Thread for completeness, wear and alignment. Correct undercut or relieving at the base of the shank.
3. Alignment of shank and eye
4. Cracks in shank and eye

5. Wear in eye and link etc, ie 8% reduction in diameter
6. Corrosion and chemical attack

Wire Ropes

Should be examined and checked for:

1. Size of loads to be lifted
2. Kinks in the rope
3. Wear in rope
4. Change in diameter (increase or decrease) and increase in length
5. Lubrication and internal condition
6. Broken wire (maximum 5% in any length equal to 10 times the diameter, but remember even 1 broken wire presents a hazard to the user or equipment in certain applications)
7. Condition of splices, ferrule secured eyes etc
8. Corrosion and chemical attack. NB With some constructions of wire rope internal corrosion can cause an increase in diameter

Fabricated Items

Should be examined and checked for:

1. General conditions of material paying particular attention to the finish of cut and machined parts which should be smooth with no stress raisers
2. Nicks, cracks, distortion, corrosion and chemical attack
3. The soundness of welds, they should be free of slag, cracks, porosity and undercut
4. Bolts should be of correct length and threaded sections should not be subject to shear. Nuts should be fully engaged and secure. Locking devices and washers must be in place.

Lifting Machines

Should be examined and checked for:

1. General operation, this will vary with the type of machine but should generally be smooth without jerkiness
2. Operation of brake or other sustaining mechanism
3. Operation of limits and safety devices
4. Correct mating of moving parts, eg gears
5. General condition of materials and anchorage's
6. Mechanical damage, cracks, distortion, corrosion and chemical attack

Note: Composite items, such as a spreader beam with two leg top suspension chain sling, shackles and pendant wire ropes, should be broken down into the component parts as necessary and examined on that basis. The complete assembly should then be checked for correct fitting, alignment of parts etc.

Marking or Re-marking

As well as marking new equipment, it is sometimes necessary to re-mark the information on in-service equipment. It must be realised that in stamping an item we are in fact introducing a potential fault as the indentations act as stress raisers. The marking is therefore made on selected areas of the item where the effects are minimised. Care must be taken so that the stamping is neither too sharp nor excessive in depth, particularly when using new stamps. The size of the stamps used should not exceed the following:

Diameter of Material	Size of Stamp
Up to & including 12.5 mm	3 mm
Over 12.5 mm up to & including 26 mm	4.5 mm
Over 26 mm	6 mm

TEST AND EXAMINATION EQUIPMENT

Test Machines and Force/Load Measuring Equipment

Many of the product standards and codes of practice which require the application of a load, or force, lay down the accuracy to which the test load or force must comply, eg BS EN 818-1 for chain requires an accuracy of $\pm 1\%$, as does BS 7121 for cranes. Historically a lesser accuracy of $\pm 2\%$ or $\pm 1.5\%$ was required for various items and some of these old standards still remain in place.

The LEEA Technical Requirements for Members, Document reference LEEA 044 dated 7 April 2004, Clause 3.1 - Tension and Compression Testing Machines and Load/Force Measuring Equipment, gives the minimum requirements for this equipment. It requires that test machines and load cells are calibrated and verified by a competent person, or authority, in accordance with BS EN ISO 7500-1 at intervals not exceeding 12 months. It further requires that the accuracy of the applied load/force must be within that required by the standard being worked to and in all cases within $\pm 2\%$ of the nominal load/force.

BS EN ISO 7500-1 has various classes or grades of machines, 0.5, 1.0 or 2.0. This relates directly to the accuracy. Grade 0.5 = $\pm 0.5\%$, 1.0 = $\pm 1\%$ and 2.0 = $\pm 2\%$. This information will be given on the certificate of calibration and verification. In some cases, dependent on the design and construction of a test machine, or load measuring device, two grades may be shown, eg grade 1.0 for one range of readings and grade 2.0 for a further range of readings.

The certificate will also give the Lower Limit of Calibration, which will be expressed as a load or force depending on the units in which the machine or device is calibrated. This is the minimum load/force that can be read from the display within the required accuracy and so test loads below this cannot be measured with this equipment. In some cases there may also be a similar restriction on the upper limit.

It is therefore important the person making any form of load test is aware of the limitations for use imposed on the test machine, or load/force measuring equipment, he is using to ensure the accuracy of the applied load meets the requirements of the standard he is working to.

Dimensional Measuring Equipment

Only the most basic of dimensional measuring equipment is usually called for in the verification of lifting gear, eg tape or rule. These should be graduated to national standards in increments of 1 mm.

For certain items a vernier may be necessary and in this case a graduation of 0.1 mm is usually sufficient when examining general lifting gear.

LEEA Technical Requirements, Clause 3.6, requires that a procedure is in place for checking and verifying measuring devices at appropriate periods. The guidance to the requirements says that for tapes and rules it will probably only be necessary to regularly check them to ensure that they are undamaged, particularly at the zero end, and remain legible. However, precision measuring equipment will require periodic verification, eg against slip gauges, depending on the nature of the device and the duty for which it is used.

Non-Destructive Test Equipment

Crack detection

When dealing with general lifting gear only rudimentary crack detection is usually performed as part of an examination, eg Dye Penetrate or Magnetic Particle to examine welds. These call for basic training of the operative to enable them to interpret the results and the equipment calls for no calibration. They are relatively inexpensive, both in terms of the equipment and the labour necessary to perform the tests.

For more detailed crack detection examinations, particularly on high value items or where additional safety requirements require a higher degree of examination, other methods used are Eddy Current, Radiography and Ultrasonic. These are expensive to perform and call for a high degree of training and skill to interpret the results.

Hardness test

Indentation methods are used to verify the hardness of lifting gear following heat treatment or where equipment is used in conditions that might affect the heat treatment. There are three basic methods, Vickers, Brinell and Rockwell.

Brinell is the most common in the lifting equipment industry. It is a relatively simple test that can be made on the finished item and calls only for basic training in order to interpret the results.

Electromagnetic wire rope examination

This is a fast method of detecting defects in long lengths of wire rope, where the rope is passed through a magnetic field. Breaks and disturbances in the magnetic field are detected and a printout of the field is given, which calls for a high degree of training and skill to interpret the results.

LEEA Technical Requirements, Clause 3.5, calls for Non-destructive test equipment to be verified at appropriate intervals in accordance with the manufacturer's instructions.

Other Equipment Necessary During an Examination

Occasionally comparators, such as thread gauges may be needed to ensure correct identification and profile of thread types and sizes, or a simple go/no go gauge, eg to check for chain wear.

In addition to load/force application and measuring equipment, distance measuring equipment and profile measuring/comparison equipment, the tester and examiner will require other basic aids from time to time. Additional lighting will often be necessary, eg wander light or torch, as well as visual aids such as a magnifying glass or dental mirror.

In the case of lifting gear general, only the most basic of tools are generally necessary. These will include a hammer, a set of pin punches (for mechanically assembled chain slings), drifts and marlin spikes (for wire ropes), a set of letter and number punches etc. In the case of machines spanners, screw drivers and circlip pliers may be required.

Basic cleaning equipment may also be necessary, eg a wire brush, cleaning cloth etc, to remove rust, dirt or debris which may obscure faults, flaws, defects or marking.

TYPES OF TEST AND WHAT THEY MIGHT TELL US

Having considered the equipment we use during an examination and test we must now look at the various tests that are available and what they might tell us. We looked at some of these in unit 1.6, now we will put them into context.

Dimensional Verification

Ensuring an item is dimensionally correct, ie measuring it, is usually a function of the initial verification to ensure the item is to the standard, specification or drawing. We also measure in-service items to determine the amount of wear, build up or loss of corrosion in wire ropes and similar matters to ensure they are within the accepted limits.

The use of comparators and gauges are of help when measuring wear or identifying threads or thread wear.

Operational Test

This test has very limited application as far as lifting gear goes and is more appropriate to lifting machines. It is a simple test to ensure the item operates as intended. During this test the item is operated through its normal functions, usually with a light load or no load.

Its use is therefore limited to items of lifting gear that have moving parts, eg a plate clamp to ensure the jaws grip the plate and can be locked into position. It is used both during the initial verification and during the in-service thorough examination.

Light Load Test

This test is not applicable to lifting gear but is for items that have screw brakes or fall arresting brakes that depend on the downward movement of the load to operate them, eg hand chain block. A load of between 2% and 5% of the WLL is raised sufficient height and then lowered. The operation is halted and the load must be sustained by the brake.

This is the most onerous test that can be applied to a brake, eg lever hoist, and, as the brake is the most safety critical part of the unit, confirms if it is safe to operate or not.

SWL and Deflection Measurement

Again this test is of limited use during the examination of lifting gear, being more appropriate to lifting machines and structures. It may be applied as part of the initial verification of a lifting beam or spreader to determine if any permanent deflection or set has taken place.

The item is subjected to a load or force, either in a test machine (eg spreaders) or by lifting a live load (eg runways and cranes), which is equivalent to the SWL (WLL). The deflection under load is measured (accuracy $\pm 5\%$) and recorded. The deflection must be within the limits set by the appropriate standard. When the load/force is removed the item

is measured to see if any permanent set has taken place and if so whether or not this is within the acceptable limits.

Proof Load Test

This is a test which is greatly misunderstood, it merely confirms that the item is capable of sustaining the applied load at the time of the test, ie is strong enough. During the test a force equal to the WLL plus an overload, usually 100% for most lifting gear, 50% for manual machines and 25% for power operated machines and structures, is applied and then released. As far as lifting gear general is concerned, its use is usually restricted to new component parts, (eg chain couplers), lengths of chain, fabricated items, (eg lifting beams and spreaders), items that rely on the action of the load for their effective operation, (eg plate clamps). It is also used when fabricated items, eg lifting beams, and load action reliant items, eg plate clamps, have been repaired to verify the newly fitted parts. It remains an important test for structural items, eg runways.

Many common items were at one time routinely proof load tested although the results were uncertain and the test could damage, or shorten the working life, of perfectly serviceable equipment. We should therefore consider these limitations so that we can understand why this test is being used less frequently than in the past.

The use of alloy steels for chain and fittings manufacture calls for higher proof loads than the traditional 2 x WLL previously applied to chain slings if the test is to be meaningful and latent defects are to be detected. BS EN 818-2 gives a table of proof loads to be applied to newly manufactured grade 8 chain which equates to 2.5 x WLL. Similarly the various standards for the fittings also call for a proof load of 2.5 x WLL, but in this case allows the radii of the fittings to be supported to prevent them collapsing during the test. Obviously, during a similar test on a made up chain sling it would be impossible to support the radii and there would effectively be point contact between the mating surfaces. Under load, fittings and master-links would distort and would be damaged beyond further use. BS EN 818-4 for Grade 8 chain slings does not therefore require mechanically assembled slings to be proof load tested. However, the safety of the sling is reliant on its correct assembly, with all retaining and locking pins in place, so a thorough visual examination, after assembly or when in service, is essential.

Similarly with wire rope slings. The traditional proof loading of a ferrule secured eye seldom detected incorrectly made eyes and even an eye with over size ferrules would hold the proof load. Therefore the harmonised standards for wire rope slings do not call for proof load testing, but BS EN 13411-3 calls for the ferrule termination to be verified by measurement and thorough examination.

In the case of eyebolts, the old British Standard 4278 remains in place and this standard does call for proof load testing.

When examining an in-service hand chain block for example, the strength is already known. Subjecting it to an overload will not therefore reveal anything that is not known, but it will put additional stress on the working parts and shorten their working life.

Breaking Load Test/Minimum Breaking Load Test

This is a test that can be applied to any product as a type test to prove the design, if the designer so wishes, and to establish that the desired factor of safety has been achieved

prior to series manufacture. Its use however needs to be controlled and it is usually only applied to samples from series production items. Of course, it is not a test that would be applicable to structures or in-service items, as the item is overloaded beyond further use or destroyed.

The textile sling standards BS EN 1492-1 and BS EN 1492-2 are examples of standards requiring this type of test. Selected samples of flat woven webbing slings and roundslings to these standards are required to be loaded up to 7 x WLL without failure. If this is successful there is no need for the test to continue to destruction, although the tested sample is scrap.

Changes have also taken place in the way that wire rope is verified. In the past a sample of the rope was loaded to destruction and the actual breaking load was recorded on the wire rope certificate. BS EN 12385 calls for a different regime, with the minimum, or specified, breaking force being given on the certificate, not the actual breaking load. This can be verified in different ways, (a) by loading a sample up to the minimum breaking load, or (b) calculation of the minimum aggregate breaking force from a sample of the wire. Again there is no need to continue to destruction if the test is successful.

Hardness Test

In the main, this test is used by manufacturers of steel component parts, eg chain connectors, and lifting gear, eg shackles, during production to verify the effectiveness of the finishing heat treatment.

Its use for in-service equipment is very restricted to one or two specialist applications where the equipment may have been affected by heat which might affect the steel. If the equipment has been subjected to a temperature above the original tempering temperature it will have been softened, or if it was subjected to very high temperatures and then sudden cooling it will have become hard and brittle.

The Brinell hardness test (BS EN 10003) is the most common used in the lifting equipment industry. A hardened steel ball is pressed into the surface of the material by a standard force. The diameter of the resulting indentation is then measured. Reference is made to tables which are calculated to compare the diameter of the indentation to the diameter of the ball used and give the hardness number. The Brinell hardness number, signified by the prefix HB, or acceptable range of numbers is given in the various product standards. Typically for items of grade 4 (or M) an HB number of 152-217 is required.

Liquid Penetration Crack Detection

There are several liquid penetration methods used, the most common being the use of two or three aerosol spray cans of liquid. Liquid penetration crack detection can be applied to ferrous and non-ferrous metal components. These tests are however limited in that they will only reveal the position of cracks and do not help to assess the depth. Neither do they reveal faults below the surface of the material, eg laminations and blow holes.

Although limited, it is a popular test for lifting gear, where no surface cracks are permitted, and is commonly used to check the welds on fabrications such as lifting beams, crane structures and similar items. This test is very simple, is readily portable and calls for the minimum of training in order to interpret the results.

The principle of the various methods is much the same. They use low viscosity liquids which flow very easily and penetrate surface cracks. In the most simple of these tests, the

area to be checked is sprayed with a background, usually white. A second spray is used which will run off the background, but will penetrate and gather in the cracks. This liquid is of a different colour and so reveals the crack as a coloured line.

A similar method uses a permanent magnet to attract the marker fluid into the crack. Its use is therefore limited to magnetic materials. However, this test must not be confused with magnetic particle crack detection.

Magnetic Particle Crack Detection

This method of crack detection will reveal both surface cracks and indicate the position of fissures within approximately 10mm of the surface. As the item under investigation has to be magnetized its use is limited to ferromagnetic materials and a few non-ferrous metals, such as nickel and tungsten.

Small items and components such as shackles are magnetized by passing them through a coil, for larger items such as lifting beams electrodes are attached to the item covering the area under investigation. The item is then sprayed with a solution of suspended iron filings. A crack or imperfection near the materials surface will distort the magnetic field and attract the iron filings. The crack is then revealed by an accumulation of particles along the line of the crack and sub-surface defects by an accumulation in the area over the fault. As cracks are only detectable when the lines of magnetic force are at a significant angle to the crack, small items are rotated and turned during the test whilst for larger items the electrodes are attached at varying positions.

For ease of identification an ultra violet light is often used which reacts with the solution and reveals the iron filings as a black line. Other systems use a background spray which allows the filings to be readily seen.

As the item has been heavily magnetized it is important that it is de-magnetized after the test to prevent the collection of magnetic particles which would damage the item when it was put into service.

Again this test call for simple training and the results are easily interpreted. It is widely used for larger in-service items that are susceptible to cracking, such as fork truck arms, and during series production of forgings.

Radiography (X-Rays) Crack Detection

This method of crack detection will locate a fault anywhere through the section which is X-rayed, however, it will only locate the fault in one plane, ie will not reveal its depth, unless a further X-ray is taken in the opposite plane. It is an expensive operation and calls for very high safety measures to be followed. As a general rule it requires the equipment to be examined to be taken to a specialist location. It is mainly used when examining production items, eg the welds of links, or when investigating a failure.

The article being X-rayed is subjected to radiation, usually from a gamma ray source, which passes through the item and falls onto photographic film. When developed the film gives a picture of the internal structure of the item in the plain of the radiation. As the radiation would damage body tissue the area must be fully shielded to prevent stray radiation and contact with persons. The source of the radiation is normally an isotope which must also be handled carefully to avoid human contact. This is a specialist test,

usually carried out under laboratory conditions and calls for great care in interpreting the results.

Eddy Current Crack Detection

This method of crack detection is suitable for use on thin sections, giving the best results for materials of less than 25mm thickness. Its use for lifting gear general is therefore very limited.

By placing a small wire coil near the test piece and then passing an alternating current through the coil an alternating magnetic field is created which, in turn, causes a current in the test piece. This effect is known as electromagnetic induction and the currents induced in the test piece are known as eddy currents.

Providing the test piece is consistent, the current flowing in the coil will remain unchanged when the coil is passed over the test piece but, if there is a crack or impurity, the current will change. By monitoring the current in the coil it is possible to detect flaws in the test piece which are not otherwise visible.

This is an expensive specialist test. The test equipment is semi-portable and so tests can be made in suitable locations. It calls for extensive training and experience to perform the test and interpret the results.

Ultrasonic Crack Detection

This method of crack detection enables the size and location of faults to be identified, however it is usually unwarranted for most items of lifting gear but is sometimes used to detect faults in very large lifting beams and similar items.

A probe containing a quartz crystal is passed over the surface of the test piece. The crystal transmits and receives high frequency vibrations which are amplified and recorded as a waveform on a cathode ray oscilloscope tube. A defect will be revealed as an intermediate echo on the screen, its depth being proportional to horizontal distance. Various methods of placing the probe are used depending on the size and location of the fault.

Again this is an expensive specialist test. The test equipment is semi-portable and so tests can be made in suitable locations. It calls for extensive training and experience to perform the test and interpret the results.

Electromagnetic Wire Rope Examination

This method is used to detect broken wires and corrosion in wire ropes and is most suitable for long lengths of rope, eg crane ropes.

The rope is passed through a tubular detector head which saturates the rope in a magnetic field. Any wire breaks or significant changes of wire section within the rope cause a disturbance of the magnetic field, which is detected and shown on a continuous paper printout.

Rope can be fed through the detector head in a continuous run, so making this a fast test suitable for long lengths of wire rope. It calls for suitable training and experience to interpret the results.

ACTIONS FOLLOWING AN EXAMINATION

Following an examination the first thing the tester and examiner must do is prepare his report, whether or not the item passed the examination. The information to be given in the report is detailed in Schedule 1 to LOLER (see unit 1.1). In some cases this report may be simplified to a check list or similar for submission to the company office for the report to be prepared for the client.

For in-service equipment, in the event of the examination revealing a defect(s) which present an immediate or imminent risk of serious or personal injury a copy of the report must be sent to the enforcing authority (usually the HSE in the UK). A prosecution may follow if this is not done. This is a duty placed on the person making the examination. Although your company may have a procedure for doing this, it is your legal responsibility to ensure this has been.

CONCLUSION

Dependant on the types of item you are dealing with, you will already be familiar with some of the tests outlined above. Some of them are carried out by the tester and examiner in the workplace or on site as a matter of daily routine. Others are specialist tests, only warranted in special circumstances or in particular production situations.

As a tester and examiner you should be aware of all of the tests that are available to you and what they will tell you. When we consider the various items of lifting equipment in the following units we will consider which of these are applicable.

UNIT NO. 1.8

CHAIN FOR LIFTING PURPOSES

Chain is the most basic of lifting media. Although capacity for capacity it is five or six times heavier than rope it has a far longer life being far more robust. It can better withstand rough usage, is less likely to damage, is almost perfectly flexible and can be stored for long periods without serious deterioration. In use it tends to show evidence of damage better than wire rope or textiles, consequently examination is more reliable. Therefore it remains the principle component of much lifting equipment. Here we will consider the various grades of chain, their relative breaking loads, proof loads and working load limits.

In order to understand the relationship between the various grades of material, and the reason for the varying factors of safety, it is necessary to know a little of the history of chain and its methods of manufacture. This will also tell us about the grading of other steel items of lifting gear as the grade marks, used to indicate the material from which they are made and the heat treatment they have been given, are the same. In unit 1.3 we learned a little of the various materials and their properties and you are advised to recap on this information.

Originally chain was hand made by blacksmiths, it was made from wrought iron, which was easily worked and could be forge welded. The method of manufacture differed little from that used by the Romans (although the quality of the material had improved slightly). Both the actual material production and the chain making process relied heavily on the skill of the people involved. The weld was made at the crown of the link by forge welding, known as a scarf weld. As a result the quality of the chain was inconsistent. Wrought iron work hardens with use; this results in brittle failure unless the chain is heat treated by annealing regularly to restore its condition. Wrought iron chain slings therefore had to be heat treated every six months by law, although load chains for certain machines were exempt.

As people became more aware of safety requirements, and as recognised standards were introduced to control the various processes, it was necessary to adopt a factor of safety that allowed for inconsistencies. A factor of safety of 5 was found to be suitable and this was carried on into many later standards for other items and grades of material.

With the advent of reliable and consistent steel production it was only a short step to mild steel chain. Whilst this had the same tensile strength as good wrought iron, it allowed for improved methods of manufacture. Instead of hand made links, chain making machines were developed and welding techniques were improved. Modern chain making is entirely automated. Links of uniform size and shape are formed and assembled from high quality materials. They are then welded, usually by the same machine, in a continuous process.

These advances in technology resulted in a standard chain that gave consistent results. It was found that a mild steel chain link; made to the standard proportions (pitch = 3 times material diameter), produced in 1 inch diameter bar had a breaking load of 30 tons. Further it was found that the relationship of the breaking load to the diameter of the bar was the same for all diameters of mild steel chain, ie the breaking load was $30d^2$ where 'd' is the diameter of the material. As a result this became known as grade 30 chain.

Although neither wrought iron nor mild steel are considered suitable for chains for lifting

purposes nowadays, they established the ground rules that are still used today. To establish the SWL the factor of safety (*ie* $\frac{\text{breaking load}}{\text{SWL}}$) of 5 was used.

A proof load (just below the limit of proportionality) of twice the SWL was applied, so it can be seen that grade 30 chain had:

$$\begin{aligned} \text{Breaking Load} &= 30d^2 \\ \text{Proof Load} &= 12d^2 \\ \text{SWL} &= 6d^2 \end{aligned}$$

The lowest grade of chain considered suitable for lifting purposes at the present time is produced from a steel that has an increased carbon content and is known as 'Higher Tensile Steel'. In the old imperial standards this was known as grade 40, where a standard 1" dia link had a breaking load of 40 tons. Thus, applying the same rules we can see that grade 40 chain had:

$$\begin{aligned} \text{Breaking Load} &= 40d^2 \\ \text{Proof Load} &= 16d^2 \\ \text{SWL} &= 8d^2 \end{aligned}$$

Hence if we take a 1/2" diameter grade 40 chain:

$$\begin{aligned} \text{Breaking Load} &= 40 \times \frac{1}{2} \times \frac{1}{2} = \frac{40}{4} = 10 \text{ tons} \\ \text{Proof Load} &= 16 \times \frac{1}{2} \times \frac{1}{2} = \frac{16}{4} = 4 \text{ tons} \\ \text{SWL} &= 8 \times \frac{1}{2} \times \frac{1}{2} = \frac{8}{4} = 2 \text{ tons} \end{aligned}$$

As technology and materials have further improved it has been possible to develop higher grades of chain using steel alloys. Grade 60 and grade 80 were both imperial alloy steel chains where the same relationship existed.

We can easily see from the grade numbers that size for size grade 40 chain was one third stronger than mild steel whereas grade 60 was twice as strong; and that grade 80 was twice as strong as grade 40.

Note: These grade numbers must not be confused with the tensile strengths of the steels. The higher the grade number, the stronger the steel; but the grade number bears no direct relation to the tensile strength of the material (MN/m²) of a standard test piece. The grades refer only to the strength of the made up chain.

In 1959 when BS 3114 was written for alloy steel load chain grade 80, the factor of safety of 5 was considered inadequate for this material as at that time it was considered that the material would be less ductile. A slightly higher factor was used and so the SWL was given as 14d² and NOT 16d² as would have been assumed, however the initial proof load was 32d². We now know that in fact a lower factor would have been adequate.

Steels do not work harden in the way that wrought iron does and no regular heat treatment is necessary. Indeed, with some of the alloy steels re-heat treatment of chain would be downright dangerous. The speed of this advance in technology was reflected in the old Factories Act 1961 which called for all chains to be annealed. Exemptions then had to be issued so that none of the grades of chain used by the late 1960's required heat treatment under the Act. There is no mention of it at all in modern legislation as it would now be considered a dangerous practice.

The above text all relates to old, withdrawn, imperial standards of chain where 'd' was the nominal diameter of the chain in inches and the loads were expressed in tons. The adoption of the metric system meant a new set of standards was necessary. BS 4942:1981 was produced as a metric standard for the various grades of chain. As the relationship of grade numbers was related to imperial units a new system of grading was required and so as to avoid confusion a lettering system was adopted.

Grade M = the metric equivalent of grade 40

Grade S = the metric grade almost equivalent to grade 60 (actually 63)

Grade T = the metric equivalent to grade 80.

In preparing this standard it was possible to take into consideration the further advances made both in technology and in quality control. Material specifications can now be maintained more consistently and chain of uniform size and performance readily produced. These improvements, together with increased knowledge and understanding, enabled the factor of safety to be reduced to 4:1 allowing for higher loads chain size for chain size.

It was also necessary to establish a relationship between size (in millimetres) and load (in tonnes). BS 4942 gave the following mean stresses for each type of chain as shown in table 1.

Table 1

Grade of chain	Mean stress at WLL N/mm ²	Mean stress at Proof Force N/mm ²	Mean stress at minimum Breaking Force N/mm ²
M	100	200	400
S	157.5	315	630
T	200	400	800

Using the above, the various loads could be calculated by multiplying the total cross-section of both sides of the chain by the Mean Stress, ie Force (Load) = Mean Stress x Cross Sectional Area. If we consider a 4mm diameter alloy steel chain Grade T chain the minimum breaking load was determined thus:

$$\begin{aligned} \text{Total cross sectional area} &= \pi \frac{d^2}{4} \times 2 \\ &= \pi \times \frac{4^2}{4} \times 2 = \pi \times 8 = 25.13 \text{ mm}^2 \end{aligned}$$

$$\text{Load} = \text{Stress} \times \text{c.s.a.} = 800 \times 25.13 = 20,106 \text{ Newtons} = 20.2 \text{ kN}$$

assuming 10,000N = 1t

Then the answer is Approximately 2t

$$\text{Proof Load} = \frac{\text{minimum breaking load}}{2} = \frac{2}{2} = \underline{1t}$$

$$\text{WLL} = \frac{\text{Minimum breaking load}}{4} = \underline{0.5t}$$

By calculating the loads for various size chains the relationships shown in table 2 are established where 'd' is in millimetres.

Table 2

Grade of Chain	WLL in terms of d^2 (t)	Proof load in terms of d^2 (t)	Minimum breaking load in terms of d^2 (t)
M	$\frac{d^2}{64}$	$\frac{d^2}{32}$	$\frac{d^2}{16}$
S	$\frac{d^2}{40}$	$\frac{d^2}{20}$	$\frac{d^2}{10}$
T	$\frac{d^2}{32}$	$\frac{d^2}{16}$	$\frac{d^2}{8}$

In early 1997 the first parts of a new standard, BS EN 818, started to appear and the final part was issued in 2002 by which time BS4942 was completely withdrawn. BS EN 818 is the harmonised European Standard for chain and chain slings. It has been prepared to enable manufacturers to demonstrate that they are meeting the essential safety requirements of the European Machinery Directive and reflects the state of the art. It is now the only standard for chain with which all new chains for lifting purposes must comply. So that the chain can be identified as complying with this standard a further change has been made to the grading system. Chain intended for use in chain sling assembly is graded using numbers, whilst chain intended as load chain for lifting appliances is letter graded. For example, the grade of chain intended for sling manufacture formerly known as grade T is now grade marked 8.

BS EN 818 makes changes to the way we define chain. In the past it was common to refer to calibrated and non-calibrated chain. In fact all chain is calibrated to some degree and so, in strict terms, these terms are incorrect. BS EN 818 therefore uses the terms 'medium tolerance' and 'fine tolerance'. So let us now consider what is meant by these terms.

BS EN 818-7 covers grade T fine tolerance chain (calibrated chain as it was previously known) of three types, T, DAT and DT. This is chain which has been manufactured to precise dimensions for use as load chain in lifting appliances. The pitch of the chain is important as it has to mate with other, moving, components. It is less ductile than the chain used for chain slings and has a harder skin to resist wear. As it is unsuitable for use as sling chain, we must be able to identify it in case we come across slings that incorrectly have been made using it.

BS EN 818-7 lays down the minimum percentage of nickel, chromium and molybdenum in the steel used for each type of chain. Type T chain is hardened and tempered, whilst types DAT and DT are case hardened. These requirements are so as to obtain the different

characteristics for the duty for which the chains are intended. The comparative WLL of each type of chain differ size for size, eg 6mm diameter type T chain has a WLL 1.1t, type DAT 0.9t and type DT 0.56t. This is also due to the different characteristics of the chains and the duties for which they are intended.

Type T chain is intended for use as load chain for manually operated blocks, or slow speed power hoists, in environments where there are no abrasive conditions. Type DAT chain is intended for use as load chain for power hoists with high speeds and working capacity, where good wear resistance is necessary to give a longer working life. Type DT chain is intended for use as load chain for power hoists in abrasive conditions. Case hardened chains type DAT and DT are not suitable for use in hand chain blocks.

Load chains to BS EN 818-7 must not be used at temperatures of 200°C or more and any chain that has been subject to such temperature must be removed from service. Type T chain may be used at temperatures no lower than -40°C, type DAT no lower than -20°C and type DT no lower than -10°C.

Medium tolerance chain, intended for sling manufacture, needs to be more ductile to withstand shock loading, however, in use it is not subject to wear and can therefore have a softer skin. As it does not mate with other, moving, parts it does not need to have such a precise pitch.

When chain is produced by machine the links are marginally misshapen, the sides having a slight curve. When the manufacturer 'calibrates' it by the application of a force, the links bed down on each other and the sides of the link straighten. As a result the chain extends by a marginal amount. In the case of load chains it is vital that the links are of precise size and form so that they engage correctly in the pocketed load wheels of the appliance. This is achieved by manufacturing the chain to a calculated undersize. The finished chain is then subjected to an increased force, which pulls it to the required even shape, size and pitch.

Various finishing treatments are then given to fine tolerance chain to increase its wear resistance, eg case hardening. The loss of some ductility due to the manufacturing and finishing processes is relatively unimportant for load chains. However these features are undesirable in a sling chain where it is less likely to wear. Sling chain is more liable to be shock loaded, so good ductility is essential.

Fine tolerance chain may be recognised in two ways. The calibrating process has the effect of removing all of the residual scale from the heat treatment process and many of the finish treatments include corrosion resistant finishes. As a result it has a bright finish and of course there is also the grade mark.

It can be seen then that correct identification of these chain types forms a vital part of any thorough examination. Should a sling be found to use chain of these grades it should be removed from service immediately. However, there is a slight problem here, which may apply to some older chain slings that can still be found in use. Slings made in the UK between 1981 and 1997 may show the letter 'T' as a grade mark. Students should therefore make themselves familiar in the recognition of fine tolerance and medium tolerance chains by looking at as many examples as possible.

Since the publication of BS EN 818, further advances have been made in material development and chains of much higher breaking loads have entered the market place. Manufacturers have followed the spirit of the standard with regard to marking and grade '10' chain slings have become very common. At least one manufacturer is developing grade '12' at the present time and research and development work is in hand to achieve even higher grades. These grades of chain are not currently covered by standards.

Test Requirements

Each of the British Standards specified the proof load/force that had to be applied by the chain manufacturer. These differed slightly with the age of the standard. The older standards tended to refer to loads, expressing them in terms of weight or mass. Recent standards, including BS EN 818, more correctly refer to forces equivalent to the force imposed by a mass of the WLL and express them in terms of the SI unit of force, the Newton.

Following the completion of all of the manufacturing processes, chain manufacturers test the chain and issue a master test certificate, which also gives the traceability back to the production, heat treatment and finishing batch. They also carry out random tests to destruction, by tensile loading, bend test and by fatigue testing to ensure the properties and qualities of the finished chain have been achieved and remain consistent.

In the case of grade 8 chain, and some older grade T sling chain from certain manufacturers, the manufacturers test force is higher than the customary 2 x WLL, being set at 2.5 x WLL. It is intended that this is the initial test, which is not intended to be repeated. The proof load for load chains is set at different percentages due to their duties.

Grade Marks

Grade marks tell us much about a piece of chain (or other forged items of gear) and these matters are important to the tester and examiner of lifting gear general, so let us consider them.

Over the years, the various standards have called for the grade mark to appear regularly throughout the length of chain. It should appear every 20th link or at intervals of 1 metre (3ft in the case of the imperial standards) whichever is the lesser distance. The links must be stamped or embossed on the least stressed part of the chain, ie on the side of the link opposite the weld. If stamps are used to mark the chain they must have a concave surface and the indentation should be such that it does not impair the mechanical properties of the chain link.

The grade mark indicates both the material from which the chain, or item, is made and, in the case of higher tensile chain to BS1663, the heat treatment that it was given. It will also tell us the standard to which the chain was made.

The vast majority of students will only ever see slings made from grade 8 or grade 10, however some slings made with chain to older standards, and therefore grades, still remain in service. It is therefore necessary for the tester and examiner to be able to recognise them. Table 3 shows the various grade markings that have been used over the years for chains suitable for use in chain slings and relates them to the standard to which they were produced. For ease of reference it refers to the breaking load and WLL in terms of d^2 .

Table 3

Grade	Breaking Load (tons)	WLL (tons)	Material	British Standard	Grade Marking
---	30d ²	6d ²	Mild steel	----	-----
40	40d ²	8d ²	Higher tensile steel chain	BS 1663	(4) Normalised (04) Hardened & tempered
60	60d ²	12d ₂	Alloy steel	BS 3113	(06)
M	40d ²	10d ₂	Higher tensile	BS 4942 Part 2	M
S	63d ²	16d ₂	Alloy steel	BS 4942 Part 4	S
T	80d ²	20d ₂	Alloy steel	BS 4942 Part 5	T
4	40d ²	10d ₂	Alloy steel	BS EN 818 - 3	4
8	80d ²	20d ₂	Alloy steel	BS EN 818 - 2	8
10	100d ²	25d ₂	Alloy steel	---	10

Note: Only BS EN 818 remains as a current standard, all of the others having been withdrawn some years ago.

CONCLUSION

As we noted, calibrated chain, or more correctly fine tolerance chain, is intended as the load chain for lifting appliances. It is of interest to the student as he needs to be able to recognise it so that should a chain sling, which has been incorrectly assembled from such chain, come before him for examination he is able to justify his decision to reject the sling.

On the other hand, medium tolerance chain intended for sling assembly and general purposes should never be used as hoist chain. You should be familiar with the grade marks, know to which standard the chain has been made and other information this may tell you. In a later unit, when we consider chain slings, we will recall some of this information.

UNIT NO. 1.9

WIRE ROPE

Although wire rope has sufficient flexibility to run around pulleys and be bent to form eyes, it is the most rigid of the lifting media. Its rigidity allows it to be passed easily under loads and through apertures, which would not be possible with any of the more flexible lifting media. When in long lengths it is stored on reels, or coiled, and must be handled carefully or it may become damaged.

Wire rope has been in common use since the late 1800's. It is a good medium for making slings, which are lighter than the equivalent capacity chain slings, and for use as winch wires and hoist ropes as it is capable of use at far higher speeds than chain. Due to its construction there are a large number of small wires at the surface and so is more susceptible to damage than chain. Further, if a wire rope sling is bent around a corner of the load or repeatedly used to lift identical loads, the rope will take on a permanent set.

In this unit we will consider the construction of wire ropes and, in particular, BS EN 12385-4: 2002, Steel wire ropes – Safety – Stranded ropes for general lifting applications, as this covers the construction of ropes used to make slings and used for most common hoist applications. We should just note here that other constructions of wire rope, for specific applications such as elevator ropes, are covered by other parts of BS EN 12385.

CONSTRUCTION

There are many constructions of wire rope which use a variety of wire sections, wire diameters and methods of spinning the wires together to obtain very different characteristics of rope with different properties for specific duties. For sling manufacture and common hoist applications ropes formed from round section wire are used. Although slings and winch wires can be made from any suitable six or eight stranded ropes, six stranded are by far the more common. We will therefore limit our considerations to six stranded ropes, but note that exactly the same principles apply to eight stranded ropes.

To form the rope, a number of single wires are twisted (laid) together to form a strand. A number of strands are then taken and twisted (laid) together around a core to form the rope. The more wires in a strand, the more flexible the resulting rope will be.

Strand Construction

A single wire, known as a king wire, is taken and then the remainder of the required number of wires are twisted around this to form a strand. There are two ways in which the strands in a rope can be laid up, Cross Lay and Equal Lay. You should note that BS EN 12385 refers to equal lay as parallel lay.

Cross lay ropes

If the wires in the strand are all of the same diameter, the pitch of the helix formed by each wire in a layer will be different from that formed by the wires in each succeeding layer. This is known as cross lay (see figure 1) as the wires in each layer cross over one with another.

In cross lay ropes high local pressure occurs between the wires due to their crossing over and this causes 'cross-nicking' which will eventually lead to breakage. Their general use is therefore limited and none of the ropes we are concerned with in our studies are cross lay.

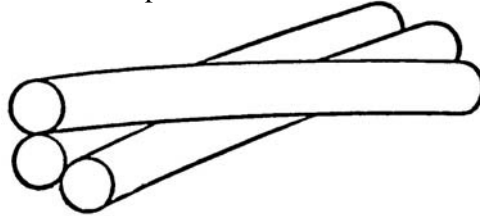

Figure 1
Cross Lay

Equal (or parallel) lay ropes

The problem of wires crossing one another is overcome by using wires of differing sizes to form the strands. Strands of this form are known as equal lay or parallel lay (see figure 2) as the wires are laid together at the same length of lay, so that the covering wires lay exactly along the valleys or crowns of the underlying wires. As a result there is continuous line contact between adjacent wires.

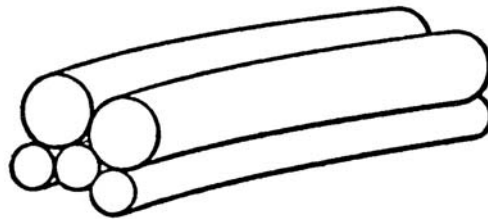

Figure 2
Equal or Parallel Lay

Wire sizes and the manner in which they are laid up can be adjusted to give varying performance characteristics to the rope for different service duties.

The most commonly used construction of wire rope for sling manufacture is 6 x 19, but 6 x 36 is also widely used and other constructions can be used. The reverse is true of hoist ropes where 6 x 36 is the more common. 6 x 19 means that there are 6 strands each of 19 wires and 6 x 36 means that there are 6 strands each of 36 wires. Both of these are equal lay ropes.

There are three basic methods of laying up a strand, 'Seale' (figure 3), 'Warrington' (figure 4) and 'Filler' (figure 5), with a fourth, hybrid, method known as 'Warrington-Seale' or 'Seale-Warrington' (figure 6).

Seale construction

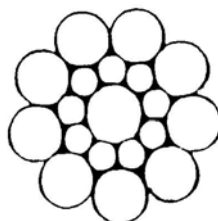

Figure 3
Seale Construction

A number of wires, nine in the case of figure 3, are laid over a king wire. The same number of larger diameter wires is then laid in the valleys formed by the inner layer so the length of lay is exactly the same.

Filler construction

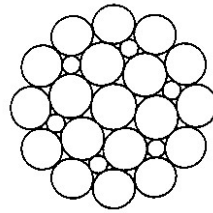

Figure 4
Filler Construction

A number of wires, six in the case of figure 4, are laid over a king wire. The same number of much smaller filler wires is laid into the valleys, thus doubling the number of valleys. Large diameter outer wires are then laid in the new valleys that have been formed, twelve in the illustration. The lay length of both the inner and outer wires will be the same.

Warrington construction

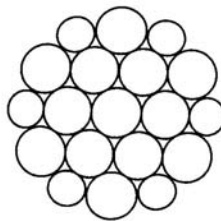

Figure 5
Warrington Construction

A number of wires, six in the case of figure 5, are laid over a king wire. The same number of identical wires is laid in the valleys formed by the first layer of wires and a similar number of small wires are laid along the crowns of the inner wires. The lay length of both the inner and outer wires will be the same.

Warrington-Seale construction or combined parallel lay

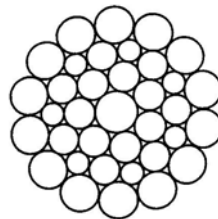

Figure 6
Warrington-Seale Construction
or Combined Parallel Lay

It is common practice to combine the attributes of the Warrington construction with that of the Seale construction. These ropes are commonly known as Warrington-Seale construction and are referred to in the BS EN 12385 series of standards as Combined Parallel Lay ropes.

The basic construction of the strand is Warrington laid with a further, outer, layer of large wires laid over the large and small wire layer so that each one lays in the valley between the alternate large and small wires.

Direction of strand lay

When a strand is being formed, the direction in which the wires are twisted may be to left, known as 's' lay, or to the right, known as 'z' lay, with all of the wires in the strand laid in the same direction. This is important when we consider the rope construction as different properties will be given to the rope if the direction of lay of the wires in the strand is the same as the direction of lay of the strand in the rope compared to if the direction of lay of the wires in the strand is in the opposite direction to the lay of the strands in the rope.

Rope Construction

We said that the most common construction of rope used for sling manufacture is 6 x 19. This is a Seale construction rope. We also said that 6 x 36 may be used to make slings and is more common as hoist rope. 6 x 36 is a combined parallel lay (Warrington-Seale) construction rope. The reason these two ropes are ideal is that they present only large diameter wires at the surface, so minimising the obvious problems of wire damage and wear in use.

The required number of identical strands are taken and twisted together around a core to form the rope in a similar manner to the way wires are taken and twisted around a king wire to form the strand.

The core of the rope may be of fibre or wire. Effectively the core is a small cord or wire rope, the purpose of which is to support the strands and keep the rope in good shape. As the construction and number of wires in the rope give differing performances to the resulting rope so does the core. A rope with a fibre core will be more flexible than one with a wire core. A side benefit is that a fibre core will retain some of the dressing and lubricant put into the rope at the time of spinning, which will be released by the core as the rope flexes when the load is applied and released. This helps to lubricate the rope internally when in use. But a wire core is better able to resist crushing and heat. Wire cores add marginally to the strength of the rope but the rope is stiffer to handle. These factors are important when selecting wire ropes for specific duties.

6 x 19 construction rope

If we look at a section through a 6 x 19 construction rope we can see that in each strand there are 19 wires. One of the wires, the king wire, runs through the centre of a strand with nine smaller diameter wires laid around this. A further nine, larger diameter, wires are laid into the valleys formed by the smaller wires. Six strands are then laid around a core to form the rope. Figure 7 shows the cross section of a 6 x 19 Seale construction rope with a fibre core. This is given the designation 6 x 19S-FC in standards, (ie 6 strands of 19 wires laid up in **Seale** construction around a **Fibre Core**).

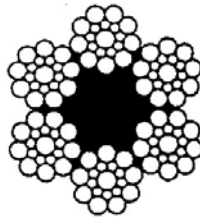

Figure 7
6 x 19 Construction Rope

6 x 36 construction rope

Similarly, if we look at a section through a 6 x 36 construction rope we can see that in each strand there are 36 wires. One of the wires, the king wire, runs through the centre of a strand with seven wires laid around this. A further layer is laid around this which totals fourteen wires. These are of two different diameters laid alternatively, the seven larger wires lying in the valleys formed by the first layer of wires and the seven smaller wires lying on the crowns of the first layer. An outer layer of fourteen wires is then laid into the valleys formed by the wires in the middle layer. Six strands are then laid around a core to form the rope. Figure 8 shows the cross section of a 6 x 36 Warrington-Seale construction rope with a wire core. This is given the designation 6 x 36WS-IWRC (ie **6** strands of **36** wires laid up in **Warrington-Seale** construction around an **Independent Wire Rope Core**).

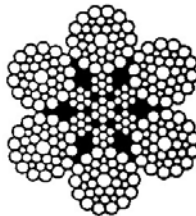

Figure 8
6 x 36 Construction Rope

The more wires in the rope the more flexible the rope will be. The fewer wires in the rope the better wear properties will be. However, these are generalisations and for most general applications will only be of secondary consideration when selecting a suitable rope.

DIRECTION OF LAY

When we looked at the direction of lay of a strand we noted that if the wires turn to the left they are designated as 's' lay and if they turn to the right they are designated 'z' lay. A similar designation is used for the rope, except that the designation is shown as upper case letters. If the strands of the rope are spun so that they turn to the right it is known as '**Z**' lay and is a **right hand lay** rope, and if they turn to the left it is known as '**S**' lay and is a **left hand lay** rope. Figure 9 shows examples of Z and S lay ropes.

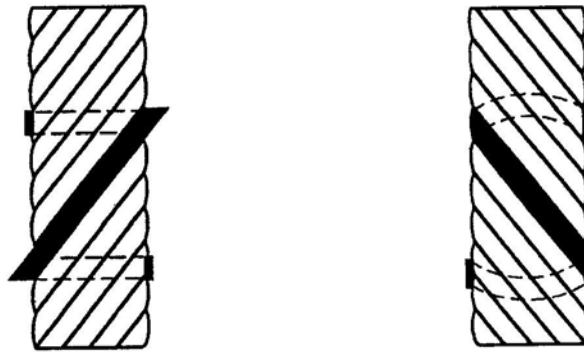

Figure 9
Z Lay and S Lay
Direction of Lay in Stranded Wire Ropes

When the wires in the strand turn in the same direction as the strand in the rope the wires will appear to run along the rope in parallel lines, this is known as **Lang's Lay** rope. If the wires in the strand turn in the opposite direction as the strand in the rope the wires appear to run across the rope at an angle, this is known as **Ordinary Lay** rope, Figure 10 shows a short section of Lang's Lay rope and a similar piece of Ordinary Lay.

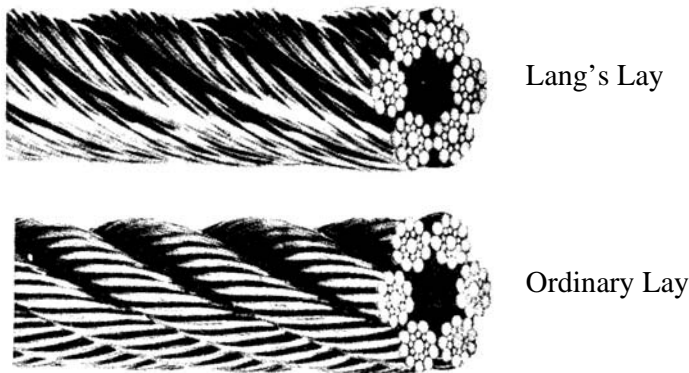

Figure 10
Lang's Lay and Ordinary Lay Ropes

Using the designations given in the BS EN 12385 series of standards a right hand ordinary lay rope is referred to as **sZ** lay, a left hand ordinary lay rope as **zS** lay, a right hand Lang's lay rope as **zZ** lay and a left hand Lang's lay rope is referred to as **sS** lay.

Special note:

Although Lang's Lay rope has better wear characteristics than Ordinary Lay, as it presents a more uniform surface, under load it has a tendency to turn. If the ends of the rope are not secured it will spin and unwind under load. It is therefore unsuitable for sling manufacture or single fall hoist applications and the Tester and Examiner must be watchful to ensure no such applications using Lang's Lay rope enter, or remain, in service.

PRE-FORMING

When both the strands and rope are being laid a process known as pre-forming can be applied. As far as our studies for Lifting Gear General are concerned we do not need to go into detail of the different properties of pre-formed and non pre-formed ropes other than to note their behaviour when they are cut and the reason for this.

If the strands and rope are made from straight wires unless the free ends are seized with a suitable soft wire they will try to straighten out. If a non pre-formed wire rope is to be cut it must be seized both sides of where the cut is to be made or the cut ends will unravel and it will be unusable. Whilst non preformed ropes have advantages for certain applications, this one characteristic makes it difficult to handle during sling manufacture and as a result it is generally not used for this purpose.

If, during the spinning process, the wires and the strands are passed over a system of rollers they will take on a helical form. By carefully setting the rollers, the wires will then follow the helix they are to adopt in the finished rope. This is known as pre-forming. If a pre-formed rope is cut the wires will lay flat and remain in position within the rope. A pre-formed rope is therefore easier to handle during sling manufacture and virtually all wire rope slings are now made from pre-formed rope.

GRADE OF ROPE

Wire ropes are made in various grades, dependant on the tensile strength of the wire used in their construction.

Rope grade 1770 is manufactured from wires with a tensile strength in N/mm² of minimum 1570 and maximum 1960.

Rope grade 1960 is manufactured from wires with a tensile strength in N/mm² of minimum 1770 and maximum 2160.

These are the only two grades of wire rope used to manufacture general purpose slings and so we will limit our consideration to these. Obviously the higher the grade the stronger the wire rope will be.

ROPE FINISH

The wires used to make wire rope are drawn to size from rolled steel bar. This is a process of reducing the diameter in stages by drawing it through dies until the finished size is achieved. During this process, or immediately following this process, heat treatment and different protective finishes can be given to the wire.

A wire which is drawn will be smooth and will appear to have a slight shine to its surface. This is known as bright finish and a wire rope made from such wires is also known as bright wire. The surface will react with the oxygen in the atmosphere, ie oxidise, and will eventually rust. The speed of oxidation will depend on the conditions of storage and of use. Special dressings can be added to delay this in some applications.

Coatings and plating added to the wire during manufacture provide protection from oxidation. The most common of these finishes is galvanising, where a surface coat of zinc is given to the wire. Not only will this coating resist oxidation but, because the zinc

coating is softer than the steel from which the wire is made, it will also act as a bearing as the wires move against one another during use, so adding to the ropes wear resistance.

BS EN 12385 uses the symbol 'U' to denote uncoated or bright finish. For zinc finishes the symbol will depend on the class of the coated finish, eg class A zinc finish is designated 'A'.

ROPE DETAILS AND DESIGNATION

In order to understand the documentation supplied with a new wire rope, eg rope certificate, or to be able to order a replacement rope, it is necessary to understand the designations given to them. Different manufacturers and suppliers will present this information in varying ways so we need to know what information we should expect to be given. The following is a list of typical information that might be required with the rope.

- 1) Length of rope
- 2) Standard to which the rope conforms
- 3) Nominal diameter of rope*
- 4) Construction of rope*
- 5) Type of core*
- 6) Grade of rope*
- 7) Wire finish*
- 8) Direction of lay and type of lay*
- 9) If the rope is preformed
- 10) If special lubrication has been applied
- 11) Minimum breaking load

*BS EN 12385 requires the designation to be made up of the six pieces of information indicated above.

Eg, consider a 20mm diameter right hand ordinary lay wire rope of 6 x 36 Warrington-Seale construction with a wire core made in 1770 grade wire with a bright finish. Following BS EN 12385 the designation will then be:

20 6x36WS-IWRC 1770 U sZ.

CONCLUSION

In this unit we have looked at the manufacture of a limited range of wire ropes, which are suitable for the manufacture of general purpose use for slings, winch ropes and hoist ropes and noted some of the more important aspects and characteristics. For those students who are unfamiliar with wire rope it is suggested that you look at as many samples as possible, as well as manufacturer's and supplier's catalogues.

BS EN 12385 is a multi-part standard, of which parts 1 to 4 are of particular interest to students of this course. Later, when we consider wire rope slings, we will be making reference to the wire ropes discussed here.