

NFPA[®]

1194

Standard for
Recreational Vehicle Parks and
Campgrounds

2021



Copyright © 2020 National Fire Protection Association®. All Rights Reserved.

NFPA® 1194

Standard for

Recreational Vehicle Parks and Campgrounds

2021 Edition

This edition of NFPA 1194, *Standard for Recreational Vehicle Parks and Campgrounds*, was prepared by the Technical Committee on Recreational Vehicles. It was issued by the Standards Council on June 1, 2020, with an effective date of June 21, 2020, and supersedes all previous editions.

This edition of NFPA 1194 was approved as an American National Standard on June 21, 2020.

Origin and Development of NFPA 1194

The earliest activity of NFPA in the development of standards for recreational vehicle parks was in 1937, and the first NFPA standard on the topic, officially adopted in 1940, was entitled *Standard for Trailer Coaches and Trailer Coach Camps*. A revision of the 1940 standard was adopted by NFPA in 1952 (post-World War II), entitled NFPA 501, *Standards for Fire Prevention and Fire Protection in Trailer Coaches and Trailer Coach Courts*. In 1960, NFPA acted to approve a revised version that divided the earlier text into two parts — one designated NFPA 501A, adopted that year as *Standard for Fire Protection in Trailer Courts*, and the other designated NFPA 501B, adopted in 1971 as *Standard for Fire Prevention and Fire Protection in Mobile Homes and Travel Trailers*. NFPA 501B was further amended in 1963, and in 1964, a revision of NFPA 501A was approved.

During the years 1962–1964, the standards activities of the Mobile Homes Manufacturers Association and the Trailer Coach Association were consolidated. They produced standards under the American Standards Association (now known as ANSI) entitled *American Standard Installations of Plumbing, Heating and Electrical Systems in Travel Trailers* (A119.2-1963) and a similar *Standard on Mobile Homes* (A119.1-1963). These interorganizational arrangements were completed in 1964, and in 1969, the newly formed Recreational Vehicle Institute was added as a fourth cosponsor.

The first standard covering any aspect of recreational vehicle parks completed by the current ANSI-sponsored committee was the *Electrical Standard for Recreational Vehicle Parks* (NFPA 501D-1971/ANSI A177.2-1972, subsequently redesignated as ANSI A119.4-1972). This edition of NFPA 1194 was prepared and published to update the previous material covering electrical safety in the 1964 edition of NFPA 501A, *Standard for Fire Prevention and Fire Protection in Trailer Courts*. In the 1971 edition of NFPA 70, *National Electrical Code*, electrical requirements for trailer courts first appeared, based largely on NFPA 501D-1971. Since it obviously was necessary to maintain coordination between NFPA 501D and NFPA 70, the sponsoring committees established liaison procedures so that the intent of Chapter 6 of the 1977 edition of NFPA 501D was identical to that of Part B of Article 551 of NFPA 70. Companion NFPA documents to NFPA 501D, besides NFPA 70, were NFPA 1192, *Standard on Recreational Vehicles*, and NFPA 501A, *Standard for Fire Safety Criteria for Manufactured Home Installations, Sites, and Communities*.

Sponsorship for the 1977 edition of NFPA 501D was held jointly by the NFPA and the Recreational Vehicle Industry Association (RVIA). The standard was developed by the Sectional Committee on Recreational Vehicle Parks and Campgrounds, which operated under the Correlating Committee on Mobile Homes and Recreational Vehicles. The 1977 edition included substantive revisions to the previous edition in Chapter 6, Electrical Systems.

The 1982 edition, renamed *Standard for Fire Safety Criteria for Recreational Vehicle Parks and Campgrounds*, was produced by the Committee on Fire Safety for Recreational Vehicles, formed on June 20, 1979. The committee was responsible for developing a standard for fire safety for recreational vehicles and recreational vehicle parks, and, therefore, the 1982 edition excluded all sections of the previous editions not considered within the committee scope. Sections dealing with environmental health and sanitation were notably excluded, as were requirements for park electrical

systems, which are addressed by reference to *NFPA 70*. Modifications also were made in sections dealing with definitions and fire safety and to conform to the *NFPA Manual of Style*.

The 1986 edition included very minor reference changes and revised definitions. The 1990 edition contained a completely revised chapter on fire safety requirements, Chapter 3, so that non-fire safety items could be moved to other chapters handled by the ANSI A119 Committee. The standard was reconfirmed in 1993, and some sections that were considered operational concerns were deleted from Chapter 3 in the 1996 edition.

The 1999 edition of NFPA 501D was renumbered as NFPA 1194, and the duplicate requirement for a refuse disposal system was deleted from Chapter 3.

Only minor technical changes were made in the 2002 edition. However, the document was completely reorganized and editorially revised to comply with the requirements of the *Manual of Style for NFPA Technical Committee Documents*.

Prior to the 2005 edition, the requirements for environmental health and sanitation were developed by the ANSI A119 Accredited Standards Committee, of which the RVIA was Secretariat. The requirements for fire safety were added, published, and distributed under one cover as ANSI A119.4/NFPA 1194 by ANSI, NFPA, and RVIA.

Through an agreement with the RVIA, responsibility for development of the standard was transferred to NFPA; therefore, the requirements for the design and construction features for recreational vehicle parks and campgrounds that are appropriate to provide adequate environmental health and sanitation, safety of electrical distribution systems, safety of LP-Gas storage and dispensing, and fire protection were combined into one standard, NFPA 1194.

The 2005 edition of NFPA 1194 was also subjected to editorial revisions in accordance with the *Manual of Style for NFPA Technical Committee Documents*. Technical changes to the standard included revisions of requirements to address the larger scale of recreational vehicles and to provide specific requirements for wildland/urban interface areas.

The 2008 edition provided new requirements for dead-end roads in excess of 100 feet in length. Associated annex material was added to depict a range of dead-end situations. New requirements also were added to address propane containers.

The 2011 edition included an updated and expanded definition of *recreational vehicles* as well as supporting material in the annex that described the various types of recreational vehicles. These sections were modified to be consistent with and match the wording in NFPA 1192, *Standard on Recreational Vehicles*.

The 2014 edition included a new requirement for a waste treatment system.

For the 2018 edition, the term *recreational park trailer* was replaced with *park model RV*. A new annex, Annex D, provides guidance on park operations.

For the 2021 edition, new provisions have been added to address grouped utility connection assembly pull-through sites and accessible camping unit sites. New annex language and figures have been added to provide additional insight to the provisions of the standard.

Technical Committee on Recreational Vehicles

Doug Mulvaney, Chair
Kampgrounds of America, Inc., MT [U]

Bruce A. Hopkins, Secretary
Recreation Vehicle Industry Association, IN [M]
Rep. Recreation Vehicle Industry Association

Leo Akins, Forest River, Inc., IN [M]
Thomas R. Arnold, T. R. Arnold & Associates, Inc., IN [RT]
Charles N. Ballard, Pacific West Associates, Inc., WY [SE]
Christopher J. Bloom, CJB Fire Consultants, OR [SE]
Jeffrey A. Christner, Grand Design RV, LLC/Winnnebago, IN [M]
Jeff D. Colwell, Colwell Consulting, AZ [SE]
Richard L. Day, Michigan State Fire Marshal's Office, MI [E]
Shane Devenish, Canadian RV Association, Canada [M]
Khaled E. Habib, CSA International, Canada [RT]
Ryan Hyer, Testing Engineers International, UT [RT]
James Alan Johnson, Recreational Adventures Company, SD [U]
Rep. National Association of RV Parks & Campgrounds

Mark Luttich, Nebraska Public Service Commission, NE [E]
David M. Mihalick, Thor Industries Inc., IN [M]
Kerry Parrott, Stahl Engineering & Failure Analysis, LLC, IN [SE]
Craig Sedlacek, Washington State Department of Labor & Industries, WA [E]
Paul Sinclair, Bucars RV Centre, Canada [M]
Rep. Recreation Vehicle Dealers Association of Canada
Homer A. Staves, Staves Consulting Inc., MT [SE]
Bruce J. Swiecicki, National Propane Gas Association, IL [IM]
Rep. National Propane Gas Association
Leslie Woodward, Fairview USA Inc., NY [IM]

Alternates

Joseph M. Bloom, Bloom Fire Investigation, OR [SE]
(Alt. to Christopher J. Bloom)
Shane B. Daugherty, Washington State Department of L&I FAS, WA [E]
(Alt. to Craig Sedlacek)
Wade Elliott, Utility Services Group, Inc., WA [U]
(Alt. to James Alan Johnson)
Dale Jordal, Winnnebago Industries, Inc., IA [M]
(Alt. to Jeffrey A. Christner)
Joe Kleinmigh, Keystone RV Company, IN [M]
(Alt. to David M. Mihalick)

Benjamin Knox, Colwell Consulting LLC, AZ [SE]
(Alt. to Jeff D. Colwell)
Lisa A. Mullen, Forest River, Inc., IN [M]
(Alt. to Leo Akins)
Kent Perkins, Recreation Vehicle Industry Association, VA [M]
(Alt. to Bruce A. Hopkins)
Douglas R. Stahl, Stahl Engineering & Failure Analysis, LLC, IN [SE]
(Alt. to Kerry Parrott)
Neil Staves, Staves Consulting, MT [SE]
(Alt. to Homer A. Staves)

Jacqueline Wilnot, NFPA Staff Liaison

This list represents the membership at the time the Committee was balloted on the final text of this edition. Since that time, changes in the membership may have occurred. A key to classifications is found at the back of the document.

NOTE: Membership on a committee shall not in and of itself constitute an endorsement of the Association or any document developed by the committee on which the member serves.

Committee Scope: This Committee shall have primary responsibility for documents on the fire safety criteria for recreational vehicles and recreational vehicle parks.

Contents

| | | | |
|---|---------|--|----------|
| Chapter 1 Administration | 1194- 5 | Chapter 6 Fire Safety | 1194- 11 |
| 1.1 Scope. | 1194- 5 | 6.1 Fire Detection and Alarm Services. | 1194- 11 |
| 1.2 Purpose. | 1194- 5 | 6.2 Fire Safety Rules and Regulations for Recreational Vehicle Parks and Campgrounds — Posting of Emergency Information. | 1194- 11 |
| 1.3 Application. | 1194- 5 | 6.3 Propane Containers. | 1194- 11 |
| 1.4 Retroactivity. | 1194- 5 | | |
| 1.5 Equivalency. | 1194- 5 | | |
| 1.6 Units. | 1194- 5 | | |
| Chapter 2 Referenced Publications | 1194- 5 | Chapter 7 Environmental Health and Sanitation | 1194- 11 |
| 2.1 General. | 1194- 5 | 7.1 General. | 1194- 11 |
| 2.2 NFPA Publications. | 1194- 5 | 7.2 Potable Water Supply and Distribution. | 1194- 11 |
| 2.3 Other Publications. | 1194- 6 | 7.3 Potable Water Connections at Individual Sites. | 1194- 12 |
| 2.4 References for Extracts in Mandatory Sections. | 1194- 6 | 7.4 Drinking Fountains. | 1194- 12 |
| | | 7.5 Sanitary Conveniences. | 1194- 12 |
| Chapter 3 Definitions | 1194- 6 | 7.6 Number, Location, and Arrangement of Toilets, Urinals, and Lavatories. | 1194- 12 |
| 3.1 General. | 1194- 6 | 7.7 Showers. | 1194- 13 |
| 3.2 NFPA Official Definitions. | 1194- 6 | 7.8 Sewerage Facilities. | 1194- 13 |
| 3.3 General Definitions. | 1194- 6 | 7.9 Sanitary Disposal Stations. | 1194- 14 |
| Chapter 4 General Requirements | 1194- 7 | 7.10 Potable Water Supply Stations. | 1194- 14 |
| 4.1 Differing Standards. | 1194- 7 | 7.11 Refuse Disposal. | 1194- 14 |
| 4.2 U.S. Federal Regulations. | 1194- 7 | | |
| 4.3 Electrical Requirements. | 1194- 7 | Annex A Explanatory Material | 1194- 14 |
| 4.4 Wildland/Urban Interface Areas. | 1194- 7 | Annex B Typical Recreational Vehicle Park or Campground Site Plans | 1194- 19 |
| Chapter 5 General Design Criteria for Recreational Vehicle Parks and Campgrounds | 1194- 7 | Annex C Glossary | 1194- 24 |
| 5.1 Park Design and Construction. | 1194- 7 | Annex D Operations Guidelines | 1194- 25 |
| 5.2 Recreational Vehicle Site. | 1194- 8 | Annex E Informational References | 1194- 26 |
| 5.3 Recreational Park Trailer Site. | 1194- 9 | Index | 1194- 27 |
| 5.4 Camping Unit Site. | 1194- 9 | | |
| 5.5 Accessible Camping Unit Site (Stand). | 1194- 9 | | |

NFPA 1194

Standard for

Recreational Vehicle Parks and Campgrounds

2021 Edition

IMPORTANT NOTE: This NFPA document is made available for use subject to important notices and legal disclaimers. These notices and disclaimers appear in all publications containing this document and may be found under the heading "Important Notices and Disclaimers Concerning NFPA Standards." They can also be viewed at www.nfpa.org/disclaimers or obtained on request from NFPA.

UPDATES, ALERTS, AND FUTURE EDITIONS: New editions of NFPA codes, standards, recommended practices, and guides (i.e., NFPA Standards) are released on scheduled revision cycles. This edition may be superseded by a later one, or it may be amended outside of its scheduled revision cycle through the issuance of Tentative Interim Amendments (TIAs). An official NFPA Standard at any point in time consists of the current edition of the document, together with all TIAs and Errata in effect. To verify that this document is the current edition or to determine if it has been amended by TIAs or Errata, please consult the National Fire Codes® Subscription Service or the "List of NFPA Codes & Standards" at www.nfpa.org/docinfo. In addition to TIAs and Errata, the document information pages also include the option to sign up for alerts for individual documents and to be involved in the development of the next edition.

NOTICE: An asterisk (*) following the number or letter designating a paragraph indicates that explanatory material on the paragraph can be found in Annex A.

A reference in brackets [] following a section or paragraph indicates material that has been extracted from another NFPA document. Extracted text may be edited for consistency and style and may include the revision of internal paragraph references and other references as appropriate. Requests for interpretations or revisions of extracted text shall be sent to the technical committee responsible for the source document.

Information on referenced and extracted publications can be found in Chapter 2 and Annex E.

Chapter 1 Administration

1.1 Scope.

1.1.1 This standard shall provide minimum construction requirements for safety and health for occupants using facilities supplied by recreational vehicle parks and campgrounds offering temporary living sites for use by recreational vehicles, park model recreational vehicles, and other camping units.

1.1.2* This standard shall not cover the design of recreational vehicles, park model RVs, or other forms of camping units.

1.1.3 This standard shall not cover operational and maintenance practices for recreational vehicle parks and campgrounds.

1.2* Purpose. The purpose of this standard shall be to serve as a basis for regulations by authorities having jurisdiction over the facilities provided in new recreational vehicle parks and campgrounds and additions to existing facilities only.

1.3 Application.

1.3.1 The requirements of this standard shall be applied to all new recreational vehicle parks and campgrounds and additions to existing facilities only.

1.3.2 This standard shall not be applied as a stand-alone design specification or instruction manual.

1.4 Retroactivity.

1.4.1 The provisions of this standard reflect a consensus of what is necessary to provide an acceptable degree of protection from the hazards addressed in this standard at the time the standard was issued.

1.4.2 Unless otherwise specified, the provisions of this standard shall not apply to facilities, equipment, structures, or installations that existed or were approved for construction or installation prior to the effective date of the standard.

1.4.3 Where specified, the provisions of this standard shall be retroactive. In those cases where the authority having jurisdiction determines that the existing situation presents an unacceptable degree of risk, the authority having jurisdiction shall be permitted to apply retroactively any portions of this standard deemed appropriate.

1.4.4 The retroactive requirements of this standard shall be permitted to be modified if their application clearly would be impractical in the judgment of the authority having jurisdiction, and only where it is clearly evident that a reasonable degree of safety is provided.

1.5 Equivalency. Nothing in this standard is intended to prevent the use of systems, methods, or devices of equivalent or superior quality, strength, fire resistance, effectiveness, durability, and safety over those prescribed by this standard.

1.5.1 Technical documentation shall be submitted to the authority having jurisdiction to demonstrate equivalency.

1.5.2 The system, method, or device shall be approved for the intended purpose by the authority having jurisdiction.

1.6 Units. The primary units throughout this standard shall be U.S. customary units.

Chapter 2 Referenced Publications

2.1 General. The documents or portions thereof listed in this chapter are referenced within this standard and shall be considered part of the requirements of this document.

2.2 NFPA Publications. National Fire Protection Association, 1 Batterymarch Park, Quincy, MA 02169-7471.

NFPA 1, *Fire Code*, 2021 edition.

NFPA 10, *Standard for Portable Fire Extinguishers*, 2018 edition.

NFPA 58, *Liquefied Petroleum Gas Code*, 2020 edition.

NFPA 70®, *National Electrical Code®*, 2020 edition.

NFPA 72®, *National Fire Alarm and Signaling Code®*, 2019 edition.

NFPA 1141, *Standard for Fire Protection Infrastructure for Land Development in Wildland, Rural, and Suburban Areas*, 2017 edition.

NFPA 1142, *Standard on Water Supplies for Suburban and Rural Fire Fighting*, 2017 edition.

NFPA 1144, *Standard for Reducing Structure Ignition Hazards from Wildland Fire*, 2018 edition.

NFPA 1192, *Standard on Recreational Vehicles*, 2021 edition.

2.3 Other Publications.

2.3.1 ANSI Publications. American National Standards Institute, Inc., 25 West 43rd Street, 4th floor, New York, NY 10036.

ANSI A119.5, *Park Model Recreational Vehicle Standard*, 2018.

ANSI/ARI 1010, *Standard for Drinking Fountains and Self-Contained, Mechanically Refrigerated Drinking Water Coolers*, 2002.

2.3.2 U.S. Government Publications. U.S. Government Publishing Office, 732 North Capitol Street, NW, Washington, DC 20401-0001.

Title 40, Code of Federal Regulations, Part 141, "National Primary Drinking Water Regulations."

Title 42, United States Code, Chapter 6, Subchapter ZII, "Safety of Public Water Systems."

2.3.3 Other Publications.

Merriam-Webster's Collegiate Dictionary, 11th edition, Merriam-Webster, Inc., Springfield, MA, 2003.

2010 ADA Standard for Accessible Design Pocket Guide, ICC, Washington, DC, 2015.

2.4 References for Extracts in Mandatory Sections.

NFPA 1, *Fire Code*, 2021 edition.

NFPA 1192, *Standard on Recreational Vehicles*, 2021 edition.

Chapter 3 Definitions

3.1 General. The definitions contained in this chapter shall apply to the terms used in this standard. Where terms are not defined in this chapter or within another chapter, they shall be defined using their ordinarily accepted meanings within the context in which they are used. *Merriam-Webster's Collegiate Dictionary*, 11th edition, shall be the source for the ordinarily accepted meaning.

3.2 NFPA Official Definitions.

3.2.1* Approved. Acceptable to the authority having jurisdiction.

3.2.2* Authority Having Jurisdiction (AHJ). An organization, office, or individual responsible for enforcing the requirements of a code or standard, or for approving equipment, materials, an installation, or a procedure.

3.2.3 Labeled. Equipment or materials to which has been attached a label, symbol, or other identifying mark of an organization that is acceptable to the authority having jurisdiction and concerned with product evaluation, that maintains periodic inspection of production of labeled equipment or materials, and by whose labeling the manufacturer indicates compliance with appropriate standards or performance in a specified manner.

3.2.4* Listed. Equipment, materials, or services included in a list published by an organization that is acceptable to the authority having jurisdiction and concerned with evaluation of products or services, that maintains periodic inspection of production of listed equipment or materials or periodic evaluation of services, and whose listing states that either the equipment, material, or service meets appropriate designated

standards or has been tested and found suitable for a specified purpose.

3.2.5 Shall. Indicates a mandatory requirement.

3.2.6 Should. Indicates a recommendation or that which is advised but not required.

3.2.7 Standard. An NFPA Standard, the main text of which contains only mandatory provisions using the word "shall" to indicate requirements and that is in a form generally suitable for mandatory reference by another standard or code or for adoption into law. Nonmandatory provisions are not to be considered a part of the requirements of a standard and shall be located in an appendix, annex, footnote, informational note, or other means as permitted in the NFPA Manuals of Style. When used in a generic sense, such as in the phrase "standards development process" or "standards development activities," the term "standards" includes all NFPA Standards, including Codes, Standards, Recommended Practices, and Guides.

3.3 General Definitions.

3.3.1 Accessory Structure. Buildings that house offices, employee or operator living units, recreational facilities, grocery stores, convenience stores, gift shops, services, restrooms, dumping stations, showers, laundry facilities, storage units, and other support services customarily a part of a recreational vehicle park or campground operation.

3.3.2 Campground. Any parcel or tract of land under the control of any person, organization, or governmental entity wherein two or more recreational vehicle, recreational park trailer, and/or other camping unit sites are offered for use by the public or members of an organization for overnight stays.

3.3.2.1 Developed Campground. A campground with two or more recreational vehicle or recreational park trailer unit sites accessible by vehicular traffic, where sites are substantially developed and refuse disposal systems, flush toilets, bathing facilities, and water are provided.

3.3.2.2* Primitive Campground. A campground that is not accessible to vehicles and no facilities are provided for the comfort or convenience of the campers.

3.3.2.3 Semi-Developed Campground. A campground with two or more recreational vehicle or recreational park trailer unit sites, accessible by vehicular traffic. Roads and facilities (toilets and/or privies) are provided.

3.3.2.4* Semi-Primitive Campground. A campground accessible only by walk-in, equestrian, or motorized trail vehicles where rudimentary facilities (privies and/or fireplaces) might be provided for the comfort and convenience of the campers.

3.3.3* Camping Unit. A portable structure, shelter, or vehicle designed and intended for occupancy by persons engaged in RVing or camping.

3.3.4 Camping Unit Site. A specific area within a recreational vehicle park or campground that is set aside for use by a camping unit.

3.3.5 Camping Unit Stand. A specific area within a recreational vehicle park or campground set aside for use by a camping unit.

3.3.6 Density. The number of camping unit sites on a unit of land area.

3.3.7* Gross Trailer Area. The total plan area measured to the maximum horizontal projection of exterior walls in the setup mode.

3.3.8 Offset (Sewer Lines). A combination of elbows or bends in a line of piping that brings one section of the pipe out of line but into a line parallel with the other section.

3.3.9* Park Model Recreational Vehicle (also known as Recreational Park Trailer or Park Model RV). A single living unit that is primarily designed and completed on a single chassis, mounted on wheels, to provide temporary living quarters for recreational, camping, or seasonal use, is certified by the manufacturer as complying with all applicable requirements of ANSI A119.5 and (1) has a gross trailer area not exceeding 400 ft² (37.15 m²) in the setup mode or, (2) if having a gross trailer area not exceeding 320 ft² (29.72 m²) in the setup mode, has a width greater than 8.5 ft (2.59 m) in the transport mode. [2018:ANSI A119.5]

3.3.10 Park Model RV Site. See 3.3.4, Camping Unit Site.

3.3.11 Park Model RV Stand. See 3.3.5, Camping Unit Stand.

3.3.12 Propane (Liquefied Petroleum Gas, LP-Gas, LPG). Any material having a vapor pressure not exceeding that allowed for commercial propane composed predominantly of the following hydrocarbons, either by themselves or as mixtures: propane, propylene, butane (normal butane or isobutane), and butylene. [1192, 2021]

3.3.13 Public Water Supply. A municipally or privately owned and approved community water supply system designed to distribute water to consumers within a defined geographical area.

3.3.14 Rear of Site. A line designating the rearmost part of the stand that is perpendicular to the longitudinal centerline of the stand.

3.3.15 Recreational Unit Site. See 3.3.4, Camping Unit Site.

3.3.16* Recreational Vehicle (RV). A vehicle or slide-in camper that is primarily designed as temporary living quarters for recreational, camping, or seasonal use; has its own motive power or is mounted on or towed by another vehicle; is regulated by the National Highway Traffic Safety Administration as a vehicle or vehicle equipment; does not require a special highway use permit for operation on the highways; and can be easily transported and set up on a daily basis by an individual. [1192, 2021]

3.3.17* Recreational Vehicle Park. See 3.3.2, Campground.

3.3.18 Recreational Vehicle Site. See 3.3.4, Camping Unit Site.

3.3.19 Recreational Vehicle Stand. See 3.3.5, Camping Unit Stand.

3.3.20 Sanitary Disposal Station. A facility provided for emptying of the waste-holding tanks.

3.3.21* Service Structure. A structure or portion thereof that is used to house sanitary facilities, such as water closets or lavatories.

3.3.22 Sewage. Any liquid waste containing animal or vegetable matter in suspension or solution, or the water-carried wastes resulting from the discharge of water closets, laundry tubs, washing machines, sinks, dishwashers, or any other source of water-carried waste of human origin or containing putrescible material.

3.3.23 Sewer Branch. For recreational vehicle parks and campgrounds, that portion of a sewer system that receives the discharge from more than one sewer lateral.

3.3.24 Sewer Lateral. That portion of a sewer system that serves a single site or structure.

3.3.25 Sewer Main. That portion of a sewer system that receives the discharge from all sewer laterals or branches within the recreational vehicle park or campground.

3.3.26 Stand. See 3.3.5, Camping Unit Stand.

3.3.27 Utility Connection Assembly. A single hookup assembly located on the site and containing connections for any of the following: potable water, sewer inlets, electrical power, phone, or television.

3.3.28 Water Riser Pipe. That portion of the water system serving the recreational vehicle, recreational park trailer, and/or other camping unit site that extends from the water supply main through a lateral branch and terminates at a water connection.

3.3.29 Water Supply Station. A facility for supplying potable water.

Chapter 4 General Requirements

4.1 Differing Standards. Wherever nationally recognized standards and this standard differ, the requirements of this standard shall apply.

4.2 U.S. Federal Regulations. Where federal regulations under the National Highway Traffic Safety Administration supersede all or part of this standard as applied to any category of regulated motor vehicles, the federal regulations shall apply.

4.3 Electrical Requirements. All electrical installations, systems, and equipment shall comply with Article 551, Part VI, and other applicable sections of *NFPA 70*.

4.4 Wildland/Urban Interface Areas. Where campgrounds and RV parks are located in wildland/urban interface areas as determined by the authority having jurisdiction, the installations shall comply with NFPA 1141 and NFPA 1144 as applicable.

Chapter 5 General Design Criteria for Recreational Vehicle Parks and Campgrounds

5.1 Park Design and Construction.

5.1.1 Site Plans for Recreational Vehicle Parks and Developed Campgrounds.

5.1.1.1 The location and arrangement of each recreational vehicle park and campground shall meet the approval of the chief of the authority having jurisdiction.

5.1.1.2 A site plan shall be supplied to the fire, emergency medical services (EMS), and law enforcement agencies having jurisdiction.

5.1.1.3 This site plan shall show and identify camping unit sites, each stand, major structures and facilities, and water supply for fire protection purposes in the recreational vehicle park or campground, to facilitate response by emergency services such as fire, police, and ambulance.

5.1.1.4 Means of access for emergency responders shall consist of roadways, fire lanes, parking lot lanes, vacant camping unit stands, or a combination thereof, and shall be provided to all structures.

5.1.1.4.1* **Multiple Access Roads.** More than one fire department access road shall be provided when it is determined by the AHJ that access by a single road could be impaired by vehicle congestion, condition of terrain, climate conditions, or other factors that could limit access. [1:18.2.3.3]

5.1.1.5 Roads shall be designed and constructed to allow evacuation simultaneously with emergency response operations.

5.1.1.6 Bridges.

5.1.1.6.1 When a bridge is required to be used as part of a fire department access road, it shall be constructed and maintained in accordance with nationally recognized standards. [1:18.2.3.5.5.1]

5.1.1.6.2 The bridge shall be designed for a live load sufficient to carry the imposed loads of fire apparatus. [1:18.2.3.5.5.2]

5.1.1.6.3 Vehicle load limits shall be posted at both entrances to bridges where required by the AHJ. [1:18.2.3.5.5.3]

5.1.2 Roads. Minimum widths of recreational vehicle park and campground roads designed to accommodate all types and sizes of camping units shall be 10 ft (3.0 m) per traffic lane and 8 ft (2.4 m) per parallel parking lane.

5.1.2.1 Roads leading to accessory structures shall be designed and constructed to accommodate the load and turning radius of the largest apparatus typically used to respond to that location.

5.1.2.2 Roads leading to accessory structures shall be not less than 20 ft (6.1 m) of unobstructed width with a 13.5 ft (4.1 m) vertical clearance.

5.1.2.3 Road curves designed for use by all types and sizes of camping units shall have a minimum internal radius of 30 ft (9.1 m).

5.1.2.4* Turnarounds shall be provided for all dead-end roads over 100 ft (30.5 m) in length, and those designed for use by all types and sizes of camping units shall have a minimum internal radius of 30 ft (9.1 m).

5.1.2.5* **Dead Ends.** Dead-end roads in excess of 100 ft (30.5 m) in length shall be provided with approved provisions for the turning around of fire apparatus no greater than every 500 ft (152.4 m) and at the closed end.

5.1.2.6 Turning Radius. The turning radius of a road shall be as approved by the authority having jurisdiction.

5.1.3 Structures. Every structure in a recreational vehicle park or campground that does not meet the definition of a camping

unit shall be designed and constructed in accordance with applicable building codes.

5.1.4 Swimming and Bathing Facilities. If provided, such facilities shall be designed in accordance with the requirements of the authority having jurisdiction.

5.1.5 Camping Unit Site Size. The occupied area of a camping unit site shall not exceed 75 percent of the site area.

5.1.6 Separation. A stand or structure shall be located at least 10 ft (3.0 m) from any other stand or structure.

5.1.6.1 A structure shall be permitted to be closer than 10 ft (3.0 m) to its stand if it is part of the stand or serves the recreational vehicle, recreational park trailer, or camping unit using that stand, providing a minimum of 10 ft (3.0 m) is maintained to any other stand or structure.

5.1.6.2 Tents shall be exempted from 5.1.6.

5.1.7 Site Identification.

5.1.7.1 Each camping unit site shall be marked for identification.

5.1.7.2 Such markers shall be easily readable from the recreational park or campground street.

5.1.8* Stand. Each camping unit stand shall be designed and constructed at such elevation, distance, and angle with respect to its access to provide for safe and efficient placement and removal of camping units.

5.1.8.1 Each stand shall be constructed to minimize the development of ruts or low spots by vehicle tires.

5.1.8.2 Each stand shall be graded to provide drainage.

5.1.8.3 Each stand shall be a minimum of 8 ft (2.4 m) wide.

5.1.9 Gates.

5.1.9.1 The gate opening shall swing inward and shall provide a clear opening no less than 2 ft (0.61 m) wider than the gated road or driveway.

5.1.9.2 Emergency responders shall have ready access to locking mechanisms on any gate that restricts access.

5.2 Recreational Vehicle Site.

5.2.1 Recreation Vehicle Stand Construction. Each recreational vehicle site shall have a vehicular access.

5.2.2 Grouped Utility Connection Assembly for Back-In Sites.

5.2.2.1 Where a potable water supply connection, sewer inlet connection, electrical power, TV connection, and phone connection supply or discharge outlets are provided for an individual recreational vehicle stand, they shall be permitted to be grouped together in one assembly in accordance with 5.2.2.2 through 5.2.2.4.

5.2.2.2 The water and electrical assemblies shall be located on the left rear half of the site (driver's side of the parked recreational vehicle) on a line that is between 5 ft and 7 ft (1.5 m and 2.1 m) from the left edge (driver's side of the parked recreational vehicle) of the stand and shall be located at any point on this line from the rear of the stand to 15 ft (4.5 m) forward of the rear of the stand.

5.2.2.3 The sewer assembly shall be located on the left rear half of the site (driver's side of the recreational vehicle) within 3 ft (0.9 m) of the stand.

5.2.2.4 The water, electrical, and sewer assemblies shall be listed specifically for the purpose of providing services to individual recreational vehicles. *[See Figure B.1(a) through Figure B.1(f) for separate potable water supply connections, sewer inlet connections, and electrical power supply outlets at individual recreational vehicle stands.]*

5.2.3 Grouped Utility Connection Assembly Pull-Through Sites.

5.2.3.1 Where a potable water supply connection, sewer inlet connection, electrical power, TC connection, and phone connection supply or discharge outlets are provided for an individual recreational vehicle stand, they shall be permitted to be grouped together in one assembly in accordance with 5.2.3.2 through 5.2.3.4.

5.2.3.2 The water and electrical assemblies shall be permitted to be located at any point along the line that is 5 ft to 7 ft (1.5 m to 2.1 m) from the left edge of the stand (driver's side of the parked recreational vehicle) from 16 ft (4.9 m) forward of the rear of the stand to the center point between the two roads that give access to and egress from the pull-through sites.

5.2.3.3 The sewer assembly shall be located on the left rear half of the site (driver's side of the recreational vehicle) within 3 ft (0.9 m) of the stand.

5.2.3.4 The water, electrical, and sewer assemblies shall be listed specifically for the purpose of providing services to individual recreational vehicles. *[See Figure B.1(a) through Figure B.1(f) for separate potable water supply connections, sewer inlet connections, and electrical power supply outlets at individual recreational vehicle stands.]*

5.3 Recreational Park Trailer Site.

5.3.1 Recreational Park Trailer Stand Construction.

5.3.1.1 Each recreational park trailer stand shall be installed using a method to accommodate the recreational park trailer setup and minimize the possible settling of the recreational park trailer in its setup mode.

5.3.1.2 Recreational park trailer sites shall have a potable water supply connection, sewer inlet connection, and electrical power supply for each individual recreational park trailer stand.

5.3.2 Grouped Utility Connection Assembly. The utility connections shall be permitted to be grouped together in one assembly in accordance with 5.3.2.1 and 5.3.2.2.

5.3.2.1 The assembly shall be located on the left rear half of the site (left side of the recreational park trailer) within 6 ft (1.8 m) of the stand.

5.3.2.2 For the purpose of providing utility connections to individual park model RVs, the assembly shall be listed for recreational vehicle or recreational park trailer use. *[See Figure B.1(c) and Figure B.1(f) for separate potable water supply connections, sewer inlet connections, and electrical power supply outlets at individual recreational park trailer stands.]*

5.4 Camping Unit Site.

5.4.1 Each camping unit site shall have a designated parking space for a full-sized car or pickup truck.

5.4.2 This parking space shall be permitted to be on the camping unit site or in a common parking area.

5.4.3 These parking spaces shall be constructed to minimize the development of ruts or low spots by vehicle tires.

5.5 Accessible Camping Unit Site (Stand).

5.5.1 The minimum number of camping unit sites to provide mobility features shall be based on the total number of units provided in the campground in accordance with Table 5.5.1.

5.5.1.1 Camping unit sites with mobility features shall be comparable to, and integrated with, camping sites available to others.

5.5.1.2 At least one of each type of outdoor constructed feature and other elements provided within camping unit sites with mobility features shall comply with the applicable technical requirements.

5.5.1.3 Where more than one of the same type of outdoor constructed feature or element is provided, at least two of the same type shall be required to comply with the applicable technical requirements of 5.5.2 through 5.5.4.

5.5.1.4 When a campground owner or operator determines that a condition does not permit full compliance with this section, compliance shall be required to the extent practicable as follows:

- (1) Compliance is not practicable due to terrain.
- (2) Compliance cannot be accomplished with the prevailing construction practices.
- (3) Compliance would fundamentally alter the function or purpose of the facility or the setting.

5.5.2 Parking Spaces Within Accessible Camping Unit Sites.

5.5.2.1 Recreational Vehicles.

5.5.2.1.1 Parking spaces and pull-through spaces for recreational vehicles shall be a minimum width of 20 ft (6.1 m).

5.5.2.1.2 Where two adjacent parking spaces are provided for recreational vehicles, one parking space shall be permitted to be a minimum width of 16 ft (4.88 m).

Table 5.5.1 Minimum Number of Camping Unit Sites with Mobility Features

| Total Number of Camping Unit Sites Provided in Camping Facility | Minimum Number of Camping Unit Sites with Mobility Features |
|---|---|
| 1 | 1 |
| 2 to 25 | 2 |
| 26 to 50 | 3 |
| 51 to 75 | 4 |
| 76 to 100 | 5 |
| 101 to 150 | 7 |
| 151 to 200 | 8 |
| 201 and over | 8 plus 2 percent of the number over 200 |

5.5.2.2 Other Vehicles.

5.5.2.2.1 Parking spaces for vehicles other than recreational vehicles shall be a minimum width of 16 ft (4.88 m) to accommodate vans equipped with a lift or ramp.

5.5.2.2.2 Where two adjacent parking spaces are provided for vehicles other than recreational vehicles, one parking space shall be permitted to be a minimum width of 8 ft (2.44 m).

5.5.2.3 Surface. The surface of parking spaces and pull-through spaces shall be firm and stable.

5.5.2.4 Slope.

5.5.2.4.1 The surface slope of parking and pull-through spaces shall not be steeper than 1:48 in any direction.

5.5.2.4.2 Where the surface is other than asphalt, concrete, or boards, slopes not steeper than 1:20 shall be permitted where necessary for drainage.

5.5.2.5 Access Aisle. An access aisle on the driver's side of the vehicle shall measure a minimum of 4 ft (1.22 m) without impediment of a slideout, to enable a person using a wheelchair to access utilities located on the driver's side of the vehicle.

5.5.2.6 Clear Space. The clear space on the passenger side of the vehicle shall have a minimum width of 8 ft (2.44 m) to accommodate a wheelchair lift.

5.5.3 Accessible Tent Pads and Tent Platforms.

5.5.3.1 General.

5.5.3.1.1 Tent pads and tent platforms shall be defined spaces with prepared surfaces for setting up and securing tents.

5.5.3.1.2 When a campground owner or operator determines that a condition does not permit full compliance with a specific provision, the tent pad and tent platform shall comply with the provision to the extent practicable.

5.5.3.2 Clear Ground Space. Clear ground space shall be provided on all usable sides of tent pads and tent platforms.

5.5.3.3 Size. The clear ground space shall be a minimum width of 48 in. (1220 mm).

5.5.3.4 Surface. The surface of the clear ground space shall be firm and stable and shall allow use of tent stakes and other tent securement devices.

5.5.3.5 Slope.

5.5.3.5.1 The slope of the surface of tent pads, tent platforms, and clear ground spaces shall not be steeper than 1:48 in any direction.

5.5.3.5.2 Where the surface is other than asphalt, concrete, or boards, slopes not steeper than 1:20 shall be permitted where necessary for drainage.

5.5.3.6 Height. Tent platforms shall be a maximum height of 19 in. (485 mm) measured from the clear ground space to the tent platform surface.

5.5.4 Clear Ground Space — Minimum Size and Location.

5.5.4.1 Picnic Tables. Thirty-six in. (915 mm) shall be usable on all sides of the table measured from the back edge of the benches.

5.5.4.1.1 Height. The tops of dining surfaces and work surfaces shall be a minimum of 28 in. (710 mm) and a maximum of 34 in. (865 mm) above the finish floor or ground in accordance with ADA 902.3.

5.5.4.1.2 Wheelchair Space. Picnic tables shall provide at least one wheelchair space for each 24 linear feet (7.32 m) of usable table surface perimeter.

5.5.4.1.2.1 Wheelchair spaces shall be a minimum of 30 in. × 48 in. (760 mm × 1220 mm).

5.5.4.1.2.2 Wheelchair spaces shall be positioned for a forward approach to the table and provide knee and toe clearance under the table.

5.5.4.1.3 Knee Clearance.

5.5.4.1.3.1 Minimum Required Depth. Where knee clearance is required under an element as part of a clear floor space, the knee clearance shall be a minimum of 11 in. (280 mm) deep at 9 in. (230 mm) above the finish floor or ground, and a minimum of 8 in. (205 mm) deep at 27 in. (685 mm) above the finish floor or ground.

5.5.4.1.3.2 Minimum Required Width. Knee clearance shall be a minimum width of 30 in. (760 mm).

5.5.4.1.4 Toe Clearance.

5.5.4.1.4.1 Minimum Required Depth. Where toe clearance is required at an element as part of a clear floor space, the toe clearance shall extend a minimum of 17 in. (430 mm) under the element.

5.5.4.1.4.2 Minimum Required Width. Toe clearance shall be a minimum width of 30 in. (760 mm).

5.5.4.2 Fire Rings, Grills, Fireplaces, and Woodstoves.

5.5.4.2.1 A minimum of 48 in. × 48 in. (1220 mm × 1220 mm) shall be provided on all usable sides of the fire ring, grill, fireplace, and woodstove.

5.5.4.2.2 Where fire rings, grills, or fireplaces are constructed with raised edges or walls, the maximum depth of the raised edge or wall shall be 10 in. (254 mm).

5.5.4.2.2.1 Burning Surface. A minimum of burning surface shall be no lower than 9 in. (230 mm) above the ground.

5.5.4.2.2.2 Cooking Surface. Cooking surfaces shall be no less than 15 in. (381 mm) and no higher than 34 in. (864 mm) above the clear ground space.

5.5.4.3 Trash and Recycling Receptacles. A minimum of 36 in. × 48 in. (915 mm × 1220 mm) positioned for forward approach to the receptacle opening or 30 in. × 60 in. (760 mm × 1525 mm) positioned for a parallel approach to the receptacle opening shall be provided.

5.5.4.4 Water Hydrants. A minimum space 72 in. × 48 in. (1830 mm × 1220 mm) with the long side of the space adjoining or overlapping an outdoor recreation access route or trail, as applicable, or another clear ground space shall be provided.

5.5.4.4.1 The space shall be located so that the water spout is a minimum of 11 in. (280 mm) and a maximum of 12 in. (305 mm) from the rear center of the long side of the space.

5.5.4.4.2 The hydrant shall be between 28 in. and 36 in. (710 mm and 915 mm) high.

5.5.4.5 Utility and Sewage Hookups. A minimum space 30 in. × 60 in. (760 mm × 1525 mm), with the long side of the space adjoining or overlapping an accessible parking space or pull-through space for recreational vehicles, shall be provided.

5.5.4.5.1 The space shall be located so that the hook-ups are at the rear center of the space.

5.5.4.5.2 Bollards or other barriers shall not obstruct the clear ground space in front of the hook-ups.

Chapter 6 Fire Safety

6.1 Fire Detection and Alarm Services.

6.1.1 Water Supplies for Fire Protection. Water supplies for fire protection purposes shall meet the requirements of the authority having jurisdiction. (*See also NFPA 1142 and NFPA 1.*)

6.1.2 Detection Systems in Structures Open to the Public. Fire detection and alarm systems installed in structures open to the public shall be installed in accordance with *NFPA 72*.

6.1.3 Fire Extinguishers.

6.1.3.1 Portable fire extinguishers provided by the recreational vehicle park or campground operator shall be of the multipurpose dry chemical type or equivalent.

6.1.3.2 Extinguishers shall have a minimum rating of 2-A:20-B:C.

6.1.3.3 Extinguishers shall be installed in accordance with *NFPA 10*.

6.1.4 Use of Fire Protection Equipment. The recreational vehicle park and campground operator shall instruct the park staff in the use of the fire protection equipment available in the park and define the staff's specific duties in the event of fire.

6.1.5 Evacuation Plan. Each recreational vehicle park and campground shall have a written evacuation plan approved by the authority having jurisdiction.

6.1.6 Campfire Locations. Approved designated outdoor campfire locations, if provided, shall be in areas where they will not constitute fire hazards to vegetation, undergrowth, trees, recreational vehicles, park model RV, camping units, and structures.

6.2 Fire Safety Rules and Regulations for Recreational Vehicle Parks and Campgrounds — Posting of Emergency Information.

6.2.1 Fire safety rules and regulations shall be conspicuously posted by management.

6.2.2 Regulations shall contain the following information and any additional information as required by the fire department:

- (1) Telephone number of the fire department or other information needed for summoning the fire department, such as the location of the nearest fire alarm box
- (2) Telephone number of the police department
- (3) Telephone number of the recreational vehicle park or campground (or any other data that would aid in ensuring prompt fire department response, such as the recreational vehicle park or campground name and address)
- (4) Location of the nearest public telephone if available on site

6.3 Propane Containers. Propane containers not installed in accordance with *NFPA 1192* shall be installed or stored in accordance with *NFPA 58*.

Chapter 7 Environmental Health and Sanitation

7.1 General. All plumbing shall be installed in accordance with the applicable plumbing codes of the authority having jurisdiction or with this standard.

7.2 Potable Water Supply and Distribution.

7.2.1 Quality. The supply or supplies of water shall comply with the appropriate potable water standards of the authority having jurisdiction or, in the absence thereof, shall meet the intent of Subchapter XII of 42 USC 6, 40 CFR 141, and federal regulations pursuant thereto.

7.2.2 Sources.

7.2.2.1 Only water from approved sources shall be used.

7.2.2.2 Where an approved public water supply system is available, it shall be used.

7.2.2.3 Where the recreational vehicle park or campground has its own water supply system, the components of the system shall be approved.

7.2.2.4 A water supply system that is used on a seasonal basis shall be provided with means for draining or shall be protected from freezing.

7.2.3 Prohibited Connections. The potable water supply shall not be connected to any nonpotable or unapproved water supply nor be subject to any backflow or back siphonage.

7.2.4 Supply. The water supply system shall be designed and constructed in accordance with the following:

- (1) A minimum of 25 gal (94.6 L) per day per site for sites without individual water connections
- (2) A minimum of 50 gal (189.3 L) per day per site for sites with individual water connections
- (3) A minimum of 50 gal (189.3 L) per day per site if water-flush closets are provided in restrooms

7.2.5 Pressure and Volume.

7.2.5.1 Where water is distributed under pressure, the water supply system shall be designed to provide a minimum flow pressure of 20 psi (137.8 kPa) with a minimum flow of 2 gpm (9.1 L/min) at any outlet.

7.2.5.2 The maximum pressure at any site shall not exceed 80 psi (551.2 kPa).

7.2.6 Outlets.

7.2.6.1 Water outlets shall be easily accessible and, when not piped to individual camping unit sites, shall not be located farther than 300 ft (91.4 m) from any site.

7.2.6.2 Provisions shall be made to prevent accumulations of standing water or the creation of muddy conditions at each water outlet.

7.2.7 Storage Tanks.

7.2.7.1 Water storage tanks shall be constructed of impervious materials, protected against contamination, and provided with locked, watertight covers.

7.2.7.2 Any overflow or ventilation openings shall be downfacing and provided with corrosion-resistant screening of not less than No. 24 mesh to prevent the entrance of insects and vermin.

7.2.7.3 Water storage tanks shall not have direct connections to sewers.

7.2.8 Wells, Springs, and Similar Sources.

7.2.8.1 All wells, springs, and similar sources of water intended for potable purposes shall be properly constructed, located, and protected to exclude surface contamination and to minimize the potential of contamination from unsanitary hazards.

7.2.8.2 A well equipped with a hand pump shall be protected by a concrete apron surrounding the pump suction pipe to divert waste water away from the well.

7.2.8.3 Hand pumps, when provided, shall be so designed and installed that all openings into the interior of the pump are protected so as to exclude contamination.

7.2.8.4 The top of the casing shall extend at least 1 in. (25.4 mm) above the face of the flange.

7.2.8.5 Each hand pump shall be bolted to a mounting flange securely fastened to the well casing.

7.2.8.6 Open pitcher pumps shall not be used.

7.3 Potable Water Connections at Individual Sites.

7.3.1 When provided, the water connections for potable water to individual recreational vehicle and recreational park trailer sites shall be located on the left rear half of the site within 6 ft (1.8 m) of the recreational vehicle stand or 6 ft (1.8 m) of the recreational park trailer stand. [See Figure B.1(a) through Figure B.1(f) for diagrams of typical arrangements.]

7.3.2 Each potable water connection shall consist of a water riser pipe that shall be equipped with a threaded male spigot located at least 12 in. (304.8 mm) but not more than 24 in. (609.6 mm) above grade level for the attachment of a standard water hose.

7.3.3 Potable water connections shall be equipped with an atmospheric vacuum-breaker.

7.4 Drinking Fountains. If provided, drinking fountains shall be in conformance with ANSI/ARI 1010.

7.5 Sanitary Conveniences.

7.5.1 Sanitary Facilities.

7.5.1.1 Toilets shall be provided at one or more locations in every recreational vehicle park and campground except at primitive and semi-primitive campgrounds.

7.5.1.2 Toilets shall be located within a 500 ft (152.4 m) radius from any recreational vehicle, recreational park trailer, and/or camping unit site not provided with an individual sewer connection.

7.5.1.3 Every toilet room shall have a minimum ceiling height of 7 ft (2.1 m).

7.5.1.4 Facilities for males and for females shall be appropriately marked.

7.5.1.5 Unless artificial light is provided, the total window or skylight area shall be equal to at least 10 percent of the floor area.

7.5.1.6 Unless provided with a listed mechanical ventilation system, every toilet room shall have a permanent, nonclosable, screened opening(s) having a total area not less than 5 percent of the floor area that opens directly to the exterior in order to provide proper ventilation.

7.5.1.7 A listed exhaust fan(s), vented to the exterior and having a rating in cubic feet (cubic meters) per minute of at least 25 percent of the total volume of the toilet room(s) served, shall be considered as meeting the requirements of this subsection.

7.5.1.8 All openable windows and vents to the outside shall be provided with fly-proof screens of not less than No. 16 mesh.

7.5.1.9 All doors to the exterior shall open outward, be self-closing, and be visually screened by means of a vestibule or wall to prevent direct view of the interior when the exterior doors are open.

7.5.1.9.1 Such screening shall not be required on single toilet units.

7.5.1.9.2 The interior finish of walls shall be moisture resistant to a height of 4 ft (1.2 m) to facilitate washing and cleaning.

7.5.1.10 The floors shall be resistant to water.

7.5.1.11 Any structure having flush toilets shall be provided with a floor drain in the toilet room.

7.5.1.12 Chemical and recirculating toilets shall be of an approved type.

7.5.1.13 Where provided, privies shall be of an approved type.

7.6 Number, Location, and Arrangement of Toilets, Urinals, and Lavatories.

7.6.1 In recreational vehicle parks and in semi-developed and developed campgrounds, a minimum of one toilet shall be provided for each sex up to the first 25 sites.

7.6.2 For each additional 25 sites not provided with sewer connections, an additional toilet for each sex shall be provided.

7.6.3 If water flush toilets are provided, an equal number of lavatories shall be provided up to six toilets.

7.6.3.1 One additional lavatory shall be provided for each two toilets when more than six toilets are required.

7.6.3.2 Each lavatory basin shall have a piped supply of potable water and shall drain into the sewerage system.

7.6.4 If separate facilities are provided for men and women, urinals shall be acceptable for no more than one-third of the toilets required in the men's facilities.

7.6.4.1 Only individual stall or wall-hung urinals shall be acceptable.

7.6.4.2 Floor urinals shall be prohibited.

7.6.5 Toilets shall be of an approved or listed type and shall be provided with seats with open fronts.

7.6.6 Each toilet shall be in a separate compartment and shall be provided with a door with a latch for privacy and a holder or dispenser for toilet paper.

7.6.6.1 Dividing walls or partitions shall be at least 5 ft (1.5 m) high and, if separated from the floor, shall be by a space not greater than 12 in. (304.8 mm).

7.6.6.2 Toilet compartments shall be not less than 30 in. (762 mm) in width, and there shall be not less than 30 in. (762 mm) of clear space in front of each toilet.

7.6.7 Each female toilet room shall be provided with a receptacle for sanitary napkins.

7.6.7.1 The receptacle shall be of durable, impervious, and readily cleanable material and shall be provided with a lid.

7.7 Showers.

7.7.1 Showers shall be of the individual type, and each shower area shall be visually screened from view.

7.7.2 All shower compartments, regardless of shape, shall have a minimum finished interior of 1024 in.² (0.66 m²) and shall also be capable of encompassing a 30 in. (762 mm) circle.

7.7.3 The minimum required area and dimensions shall be measured at a height equal to the top of the threshold and at a point tangent to its centerline.

7.7.4 The minimum area and dimensions shall be maintained to a point 70 in. (1778 mm) above the shower drain outlet, with no protrusions other than the fixture valve or valves, shower head, and safety grab bars or rails.

7.7.5 Each shower area shall be designed to minimize the flow of water into the dressing area and shall be properly connected to the sewerage system by means of a trapped inlet.

7.7.6 If showers are provided, an individual dressing area, visually screened from view, shall also be provided with a minimum floor area of 3 ft × 3 ft (0.9 m × 0.9 m) per shower, and such dressing areas shall be equipped with a minimum of one clothing hook and stool (or equivalent bench area).

7.7.7 The floors of showers and dressing areas shall have an impervious skid-resistant surface.

7.7.7.1 Wooden racks (duck boards) over shower floors shall be prohibited.

7.7.8 Open showers provided exclusively for the removal of sand and the like following beach activities, and when swimming suits are not removed, shall not be required to comply with the provisions of Section 7.7.

7.8 Sewerage Facilities.

7.8.1 Approval and Sewerage Disposal Facilities.

7.8.1.1 Each sewerage disposal system shall be approved.

7.8.1.2 Storm water sewers shall be separate and apart from any sewers intended for the conveyance of sewage.

7.8.2 Waste Treatment System. The waste treatment system design capacity for campground facilities, including sites, restrooms, laundry facilities, and so forth, shall be based exclusively on the total number of sites and shall be based on a minimum discharge of 50 gal (189.3 L) per day per site and a maximum discharge of 100 gal (378.5 L) per day per site.

7.8.3 Pipe Materials, Sizes, and Installation.

7.8.3.1 Piping material and design layout for sewers shall be as approved or specified by the authority having jurisdiction.

7.8.3.2 The minimum diameters of sewer laterals, branches, and mains shall be in accordance with Table 7.8.3.2.

7.8.3.3 Where the sewerage system is sized in accordance with Table 7.8.3.2, the minimum grade or slope of drainage pipe shall be not less than shown in Table 7.8.3.3.

7.8.3.4 The sewer lines shall be located to prevent damage from vehicular traffic and frost heaving.

7.8.3.5 All sewer line joints and sewer connections shall be watertight.

7.8.3.6 Cleanouts shall be provided at the upper terminal of each sewer main or branch and at intervals not exceeding 200 ft (61 m) along any straight run or portion thereof.

7.8.3.7 Every change in alignment or grade in excess of 22 degrees shall be served by a cleanout, except that a cleanout shall not be required for a single 45-degree bend or a single offset that comprises two 45-degree bends.

7.8.3.8 Manholes shall be permitted in lieu of cleanouts and shall be spaced not more than 400 ft (121.9 m) apart.

7.8.3.9 Horizontal-to-horizontal changes in direction shall be made with 45-degree “Y” branches, combination “Y” and 1/8 bend branches, or other approved fittings of equivalent sweep.

7.8.4 Sewer Inlet Connections at Individual Recreational Vehicle and Recreational Park Trailer Sites.

7.8.4.1 Where provided, the sewer connections for individual recreational vehicle and recreational park trailer sites shall be so located to minimize the risk of physical damage.

7.8.4.2 Where provided, the sewer inlet to individual sites shall be located on the left rear half of the site within 4 ft (1.2 m) of the stand for recreational vehicles and for a recrea-

Table 7.8.3.2 Minimum Diameter of Sewer Laterals, Branches, and Mains

| Maximum Number of Recreational Vehicle Sites Served | Minimum Pipe Size, (ID) Nominal | |
|---|---------------------------------|-----|
| | in. | mm |
| 5 | 3 | 76 |
| 36 | 4 | 102 |
| 71 | 5 | 127 |
| 440 | 6 | 152 |

Table 7.8.3.3 Minimum Grade or Slope of Drainage Pipe

| Pipe Size | | Slope per 100 ft (30.48 m) | |
|-----------|-----|----------------------------|-----|
| in. | mm | in. | mm |
| 3 | 76 | 20 | 508 |
| 4 | 102 | 15 | 381 |
| 5 | 127 | 11 | 279 |
| 6 | 152 | 8 | 203 |

tional park trailer. [See Figure B.1(a) through Figure B.1(f) for diagrams of typical arrangements.]

7.8.4.3 The sewer inlet connection shall consist of a sewer riser extending vertically to grade.

7.8.4.3.1 The minimum diameter of the sewer riser pipe shall be 3 in. (76.2 mm), and it shall be provided with a 4 in. (101.6 mm) inlet or a minimum 3 in. (76.2 mm) female fitting.

7.8.4.3.2 The sewer riser pipe shall be firmly imbedded in the ground and be protected against damage from heaving or shifting and the entrance of surface water.

7.8.4.3.3 The sewer riser pipe shall be provided with a tight-fitting plug or cap that shall be secured by a durable chain (or equivalent) to prevent loss.

7.8.4.3.4 The sewer riser pipe shall not be required to be individually vented, regardless of the use of traps at each inlet.

7.9 Sanitary Disposal Stations.

7.9.1 One sanitary disposal station shall be provided for each 100 recreational vehicle sites, recreational park trailer sites, and combinations or parts thereof that are not equipped with individual sewer connections.

7.9.2 Each sanitary disposal station shall be level, shall be easily accessible from the service road, and shall provide easy entry and exit for recreational vehicles and park model RV.

7.9.3 Construction of Sanitary Disposal Stations.

7.9.3.1 Unless other approved means are used, each sanitary disposal station shall have a concrete slab with a center drain inlet located so as to be on the road side (left) of the recreational vehicle or recreational park trailer.

7.9.3.2 The slab shall be not less than 3 ft × 3 ft (0.9 m × 0.9 m), at least 3½ in. (88.9 mm) thick, and properly reinforced, the surface of which is troweled to a smooth finish and sloped from each side inward to a sewer inlet.

7.9.3.3 The sewer inlet shall consist of a 4 in. (101.6 mm) self-closing, foot-operated hatch of approved material with a tight-fitting cover.

7.9.3.3.1 The hatch body shall be set in the concrete of the slab, with the lip of the opening flush with its surface to facilitate the cleansing of the slab with water.

7.9.3.3.2 The hatch shall be properly connected to a sewer inlet, which shall discharge to an approved sanitary sewerage disposal facility constructed in accordance with 7.8.1. [See Figure B.1(h) for a diagram of a typical arrangement.]

7.9.4 Flushing Facilities.

7.9.4.1 Recreational vehicle parks and developed campgrounds provided with a piped water supply system shall have means for flushing recreational vehicle and recreational park trailer holding tanks.

7.9.4.1.1 The flushing system shall consist of a piped supply of water under pressure, terminating in a valved outlet located and installed to minimize damage by automobiles, tow vehicles, recreational vehicles, or park model RV.

7.9.4.1.2 The flushing device shall consist of a properly supported riser terminating at least 24 in. (609.6 mm) above

the ground surface with a ¾ in. (19 mm) valved outlet to which is screwed a flexible hose.

7.9.4.2 The water supply to the flushing device shall be protected from backflow by means of a listed vacuum breaker located downstream from the last shutoff valve.

7.9.4.3 Adjacent to the flushing arrangement, there shall be posted a sign of durable material, not less than 24 in. × 24 in. (609.6 mm × 609.6 mm) in size, and inscribed thereon in clearly legible letters on a contrasting background shall be the following:

DANGER — NOT TO BE USED FOR DRINKING OR DOMESTIC PURPOSES.

7.10 Potable Water Supply Stations.

7.10.1 A potable water supply station for filling potable water tanks, if provided, shall be located at least 50 ft (15.2 m) from a waste disposal station.

7.10.2 When such is provided, adjacent to the potable water outlet, there shall be posted a sign of durable material, not less than 24 in. × 24 in. (609.6 mm × 609.6 mm) in size, and inscribed thereon in clearly legible letters on a contrasting background shall be the following:

POTABLE WATER — NOT TO BE USED FOR FLUSHING WASTE TANKS.

7.10.3 The potable water shall be protected from backflow by means of a listed vacuum breaker located downstream from the last shutoff valve.

7.11 Refuse Disposal. Facilities for the storage, collection, and disposal of refuse shall be provided.

Annex A Explanatory Material

Annex A is not a part of the requirements of this NFPA document but is included for informational purposes only. This annex contains explanatory material, numbered to correspond with the applicable text paragraphs.

A.1.1.2 NFPA 1192 and ANSI A119.5 are companion standards on which the provisions of this standard are largely based.

A.1.2 Facilities provided in existing recreational vehicle parks and campgrounds can be continued in use, providing such facilities do not constitute a recognized health or safety hazard.

A.3.2.1 Approved. The National Fire Protection Association does not approve, inspect, or certify any installations, procedures, equipment, or materials; nor does it approve or evaluate testing laboratories. In determining the acceptability of installations, procedures, equipment, or materials, the authority having jurisdiction may base acceptance on compliance with NFPA or other appropriate standards. In the absence of such standards, said authority may require evidence of proper installation, procedure, or use. The authority having jurisdiction may also refer to the listings or labeling practices of an organization that is concerned with product evaluations and is thus in a position to determine compliance with appropriate standards for the current production of listed items.

A.3.2.2 Authority Having Jurisdiction (AHJ). The phrase “authority having jurisdiction,” or its acronym AHJ, is used in NFPA documents in a broad manner, since jurisdictions and approval agencies vary, as do their responsibilities. Where

public safety is primary, the authority having jurisdiction may be a federal, state, local, or other regional department or individual such as a fire chief; fire marshal; chief of a fire prevention bureau, labor department, or health department; building official; electrical inspector; or others having statutory authority. For insurance purposes, an insurance inspection department, rating bureau, or other insurance company representative may be the authority having jurisdiction. In many circumstances, the property owner or his or her designated agent assumes the role of the authority having jurisdiction; at government installations, the commanding officer or departmental official may be the authority having jurisdiction.

A.3.2.4 Listed. The means for identifying listed equipment may vary for each organization concerned with product evaluation; some organizations do not recognize equipment as listed unless it is also labeled. The authority having jurisdiction should utilize the system employed by the listing organization to identify a listed product.

A.3.3.2.2 Primitive Campground. These campgrounds are accessible only by walk-in, pack-in, or equestrian campers.

A.3.3.2.4 Semi-Primitive Campground. Rudimentary facilities (privies and/or fireplaces) can be provided for the comfort and convenience of campers.

A.3.3.3 Camping Unit. The basic units include but are not limited to recreational vehicles, recreational park trailers, camping cabins, housekeeping cabins, tents, teepees, yurts, and other rental accommodations.

A.3.3.7 Gross Trailer Area. In calculating the square footage, measurements are taken on the exterior in its setup mode. Square footage includes all siding, corner trims, moldings, storage spaces, and areas enclosed by windows, but not the roof overhangs.

A.3.3.9 Park Model Recreational Vehicle (also known as Recreational Park Trailer or Park Model RV). A unit that is wider than 8.5 ft (2.59 m) typically requires a special movement permit for highway transit. These permits are issued by each individual state and requirements should be checked before transporting. [2018:ANSI A119.5]

A.3.3.16 Recreational Vehicle (RV). The product types are motorhome and towable RV. (See Figure A.3.3.16.)

Motorhome. A recreational vehicle built on a self-propelled motor vehicle chassis. The product-type categories are as follows:

- (1) *Type A Motorhome.* A motorhome constructed on a bare motor vehicle chassis.
- (2) *Type B Motorhome.* A motorhome constructed on an automotive-manufactured van-type vehicle.
- (3) *Type C Motorhome.* A motorhome constructed on a cut-away automotive-manufactured truck chassis.

Towable RV. A recreational vehicle that is mounted on wheels and designed to be towed by a motorized vehicle or a portable unit that is designed to be placed in the bed of a pickup truck. The product-type categories are as follows:

- (1) *Fifth-Wheel Travel Trailer.* A towable RV mounted on wheels and designed to be towed by a motorized vehicle by means of a towing mechanism that is mounted above or forward of the tow vehicle's rear axle.

- (2) *Folding Camping Trailer.* A towable RV mounted on wheels and designed to be towed by a motorized vehicle that is constructed with a collapsible roof and collapsible partial sidewalls that unfold and extend in the set-up mode and fold back up for travel.
- (3) *Travel Trailer.* A towable RV mounted on wheels and designed to be towed by a motorized vehicle that is constructed with a roof and sidewalls made of rigid materials.

Truck Camper. An RV designed to be placed in the bed of a pickup truck. Additional motorhome and towable RV products include the following:

- (1) *Expandable Travel Trailer.* A travel trailer constructed with at least one collapsible partial sidewall that unfolds for additional sleeping space in the set-up mode and folds back up for travel.
- (2) *Horse (Livestock) RV.* A motorhome or towable RV that contains a designated area for transporting horses (or other livestock).
- (3) *Sport Utility RV.* A motorhome or towable RV that has an entrance door wider than 36 in. (0.91 m) accessible by means of an access ramp or is promoted as having the ability to transport or store internal combustion engine vehicles or equipment.
- (4) *Truck Camper (Slide-In Camper).* An RV designed to be placed in the bed of a pickup truck.

[1192, 2021]

A.3.3.17 Recreational Vehicle Park. RV parks are primarily designed to accommodate recreational vehicles, recreational park trailers, and/or other camping units.

A.3.3.21 Service Structure. The structure might include other facilities for the convenience of the owner or the occupants of the recreational vehicle park or campground.

A.5.1.1.4.1 Where there could be possible time response delays for emergency equipment (fire, police, or ambulance services) occasioned by a single access to a recreational vehicle park or developed campground (such as might be caused by railroad crossings, limited access highways, one-way streets, or grades that can become impassable under snow or icing conditions), a second access or emergency access roadway might be required. (See also NFPA 1600 and NFPA 1144 for related information on access and evacuation.)

A.5.1.2.4 See Figure A.5.1.2.4.

A.5.1.2.5 See Figure A.5.1.2.5.

A.5.1.8 In design and construction, consideration should be given to elevation, distance, and angle with respect to access to the camping unit stand to provide for safe and efficient placement and removal of camping units.

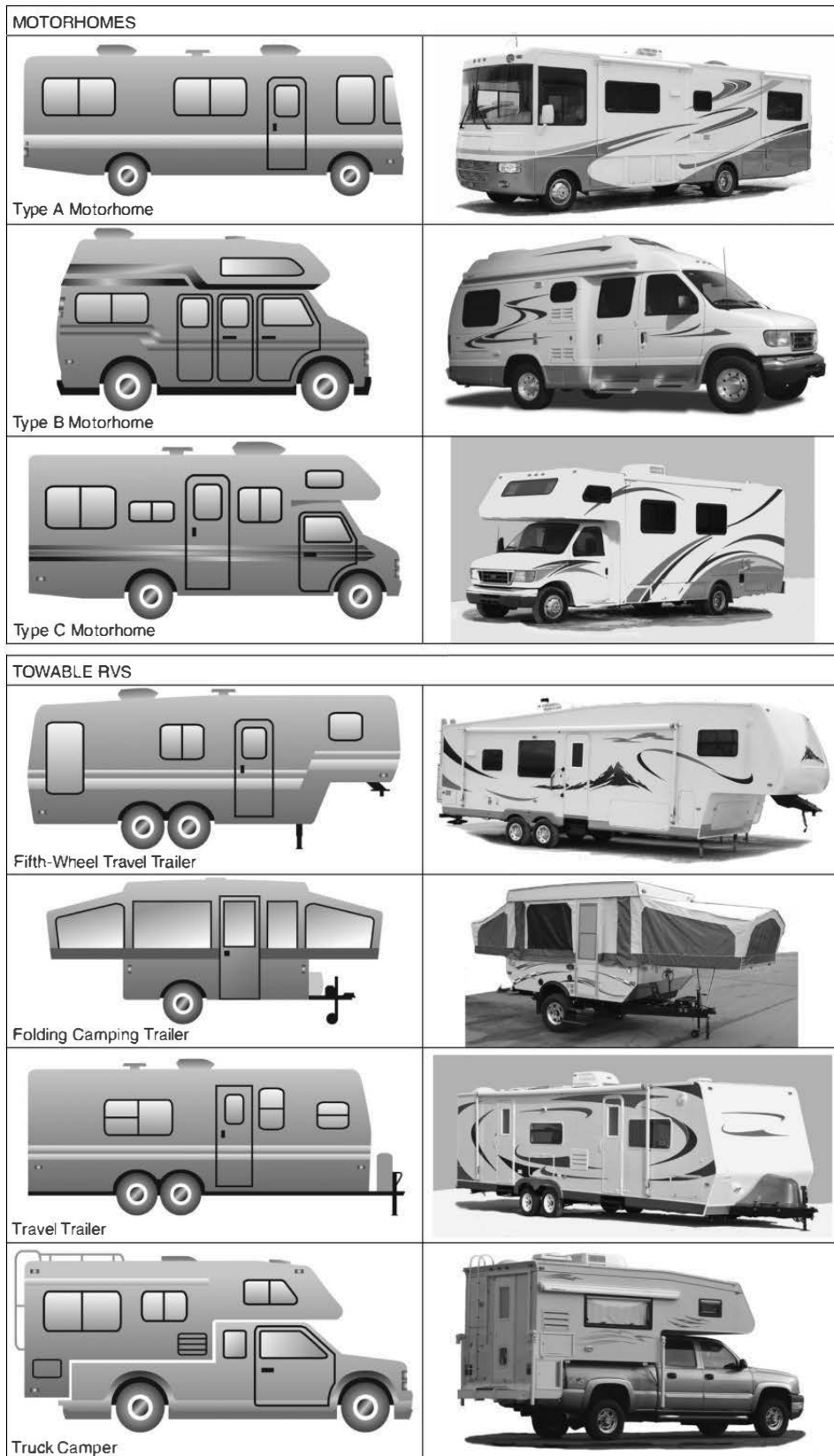

FIGURE A.3.3.16 Profiles of Each Type of RV. [1192, 2021]

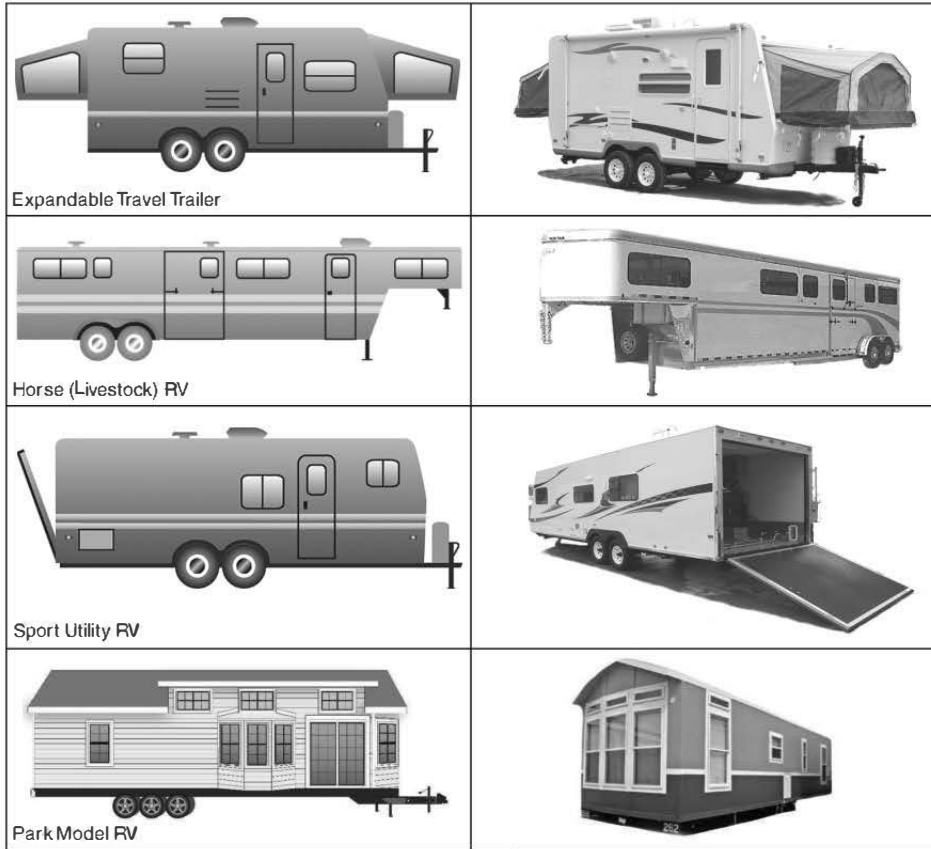

FIGURE A.3.3.16 *Continued*

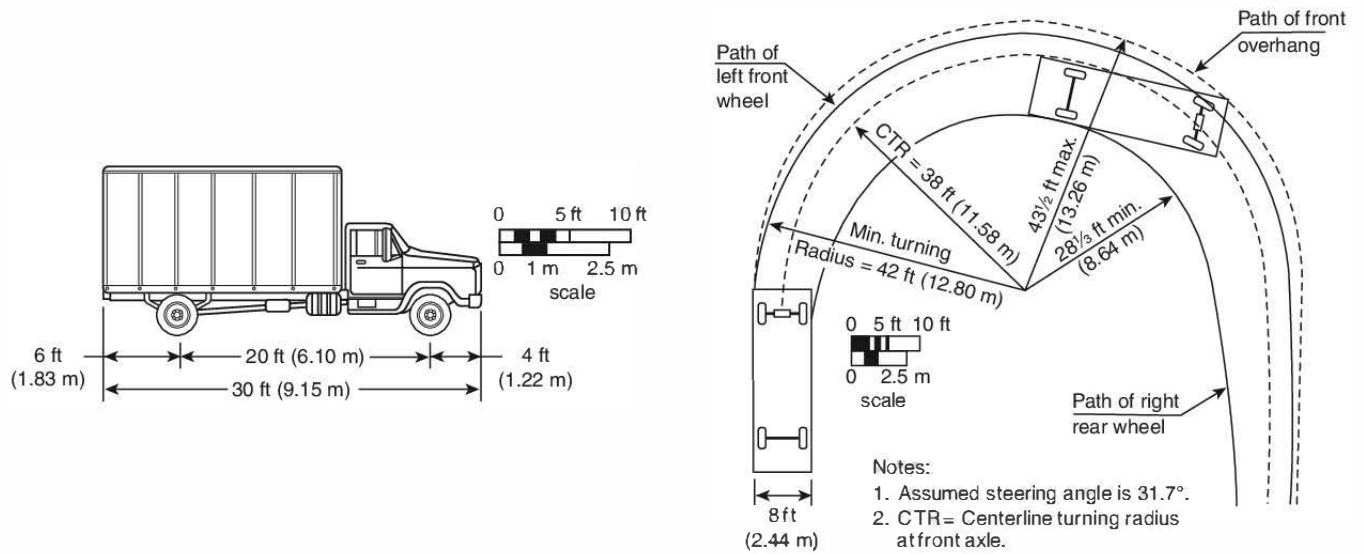

FIGURE A.5.1.2.4 **Dead-End Turning Arrangement — Radial Approach.**

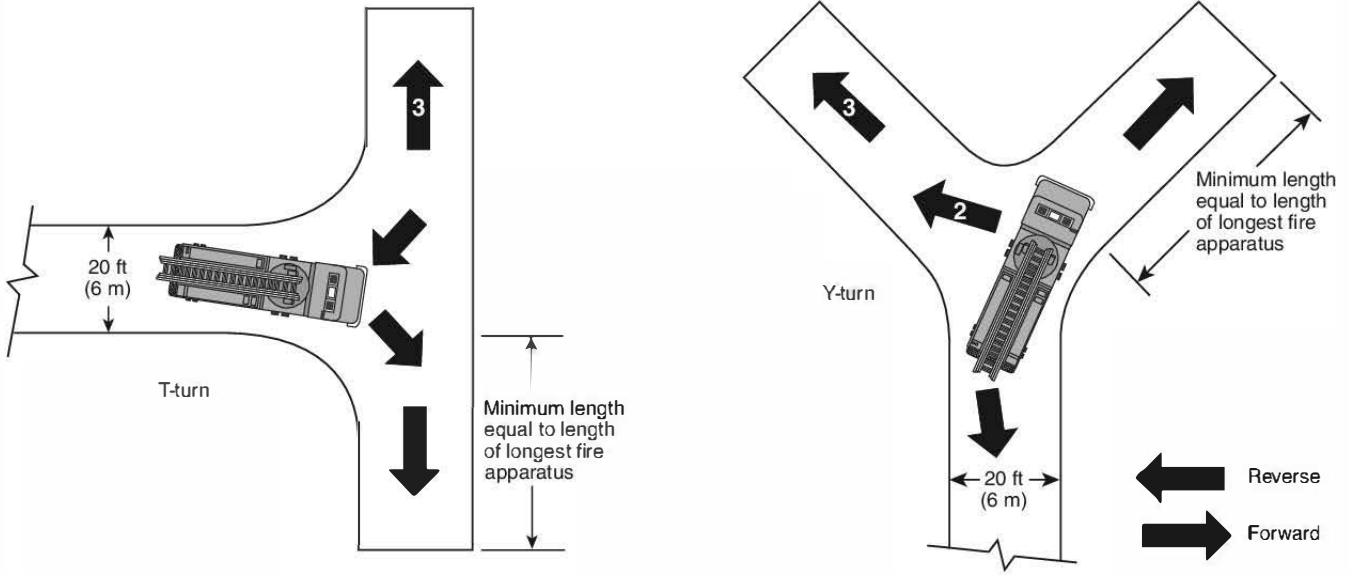

FIGURE A.5.1.2.5 Dead-End Turning Arrangement — T-Turn and Y-Turn.

Annex B Typical Recreational Vehicle Park or Campground Site Plans

This annex is not a part of the requirements of this NFPA document but is included for informational purposes only.

B.1 Figure B.1(a) through Figure B.1(h) show typical examples of utility service connections that are permitted to be used in developing new recreational vehicle and recreational park trailer sites of the “drive-through” and “reverse pull-through” types. These examples should not be interpreted as indicating mandatory requirements.

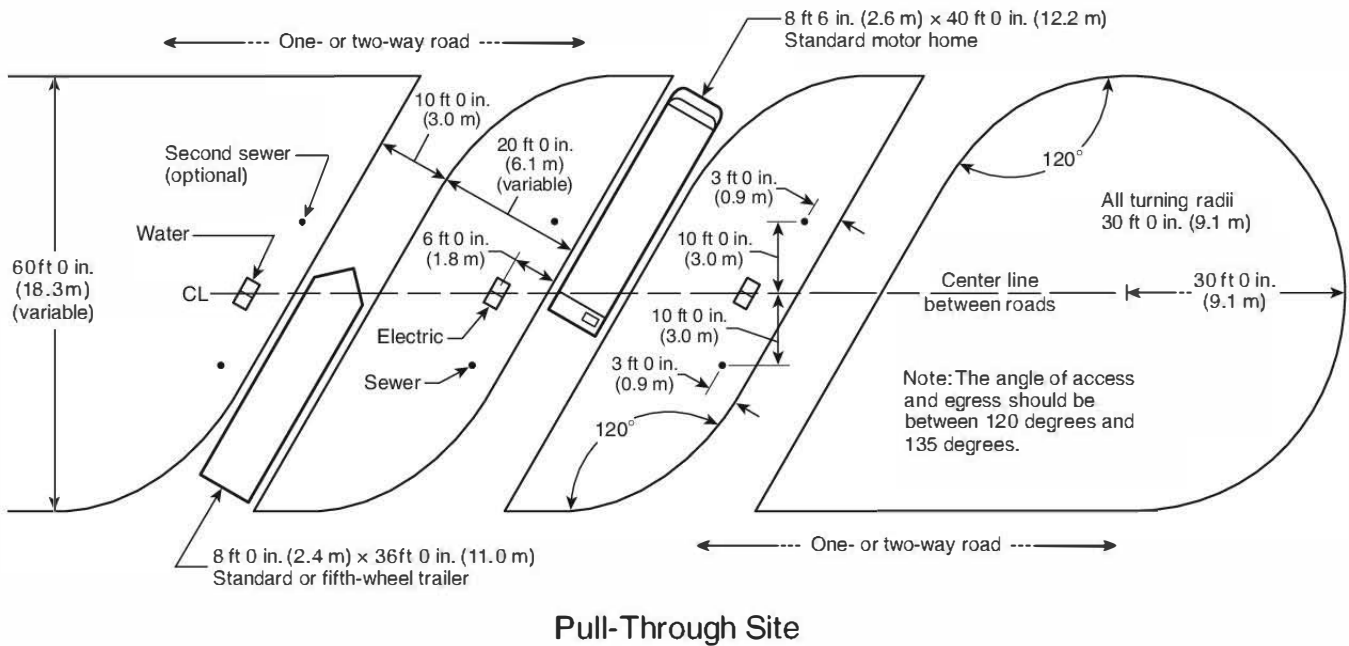

FIGURE B.1(a) Optional Arrangement for a Recreational Vehicle Park or Campground Standard Pull-Through Site Showing Water, Sewer, and Electrical Utility Connection Points.

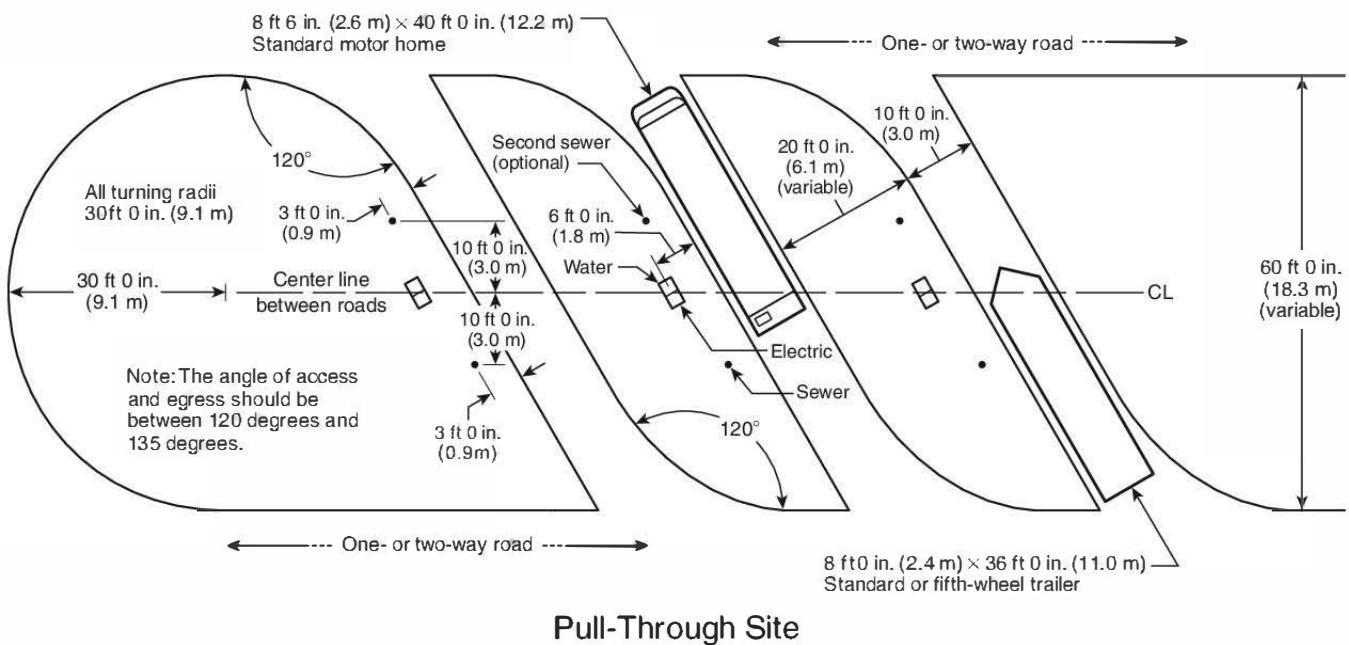
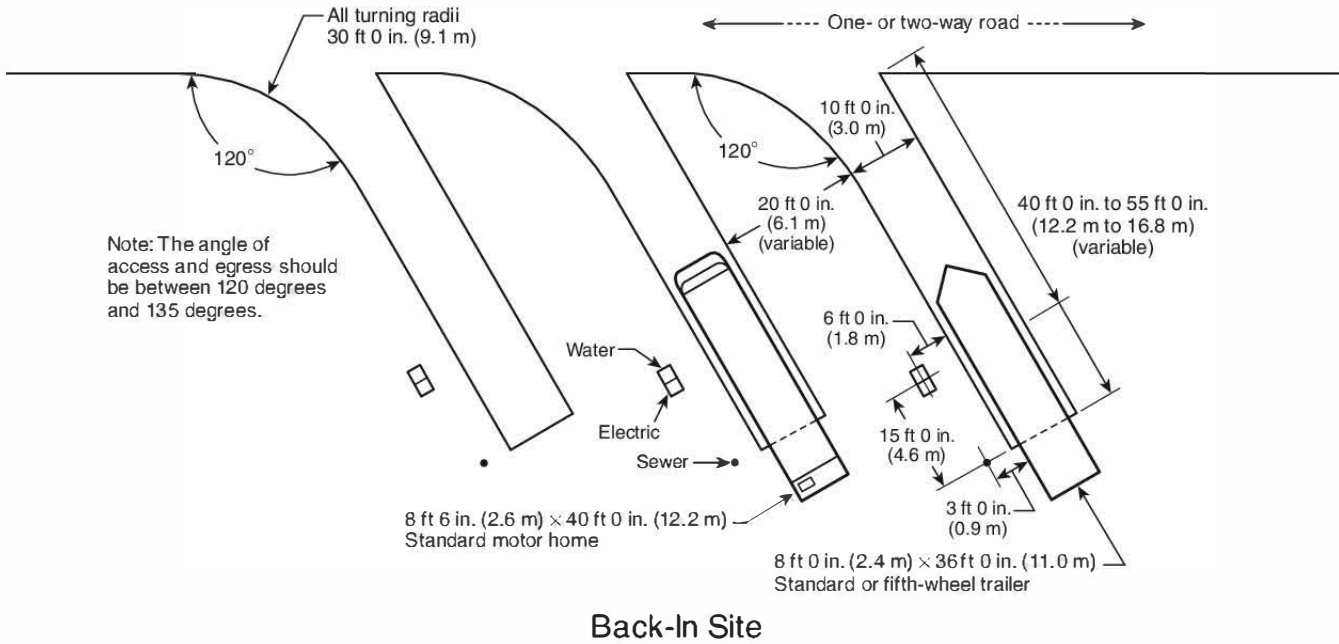
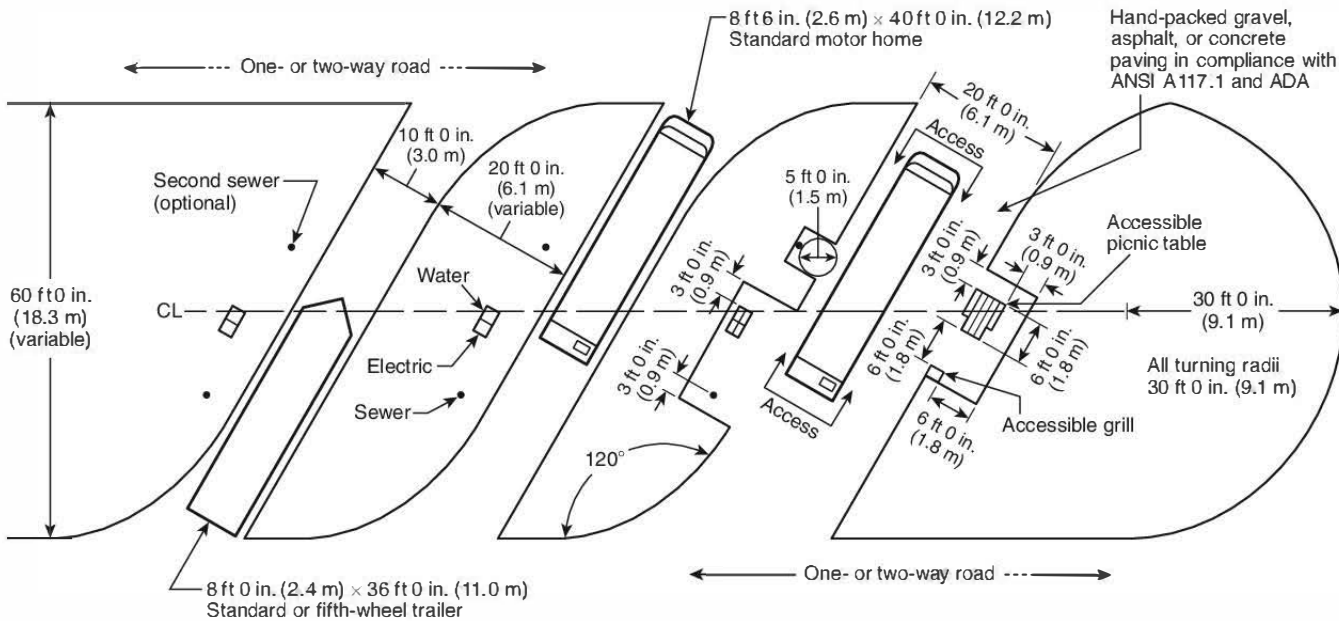

FIGURE B.1(b) Optional Arrangement for a Recreational Vehicle Park or Campground Reverse Pull-Through Site Showing Water, Sewer, and Electrical Utility Connection Points.



Back-In Site

FIGURE B.1(c) Optional Arrangement in a Recreational Vehicle Park or Campground Back-In Site for a Recreational Vehicle or Park Trailer Showing Water, Sewer, and Electrical Utility Connection Points.



- Notes:
1. The utilities are located in the same place as they are in the standard pull-through site.
 2. The angle of access and egress should be between 120 degrees and 135 degrees.

Pull-Through Site

FIGURE B.1(d) Optional Arrangement for an Accessible Recreational Vehicle Park or Campground Standard Pull-Through Site.

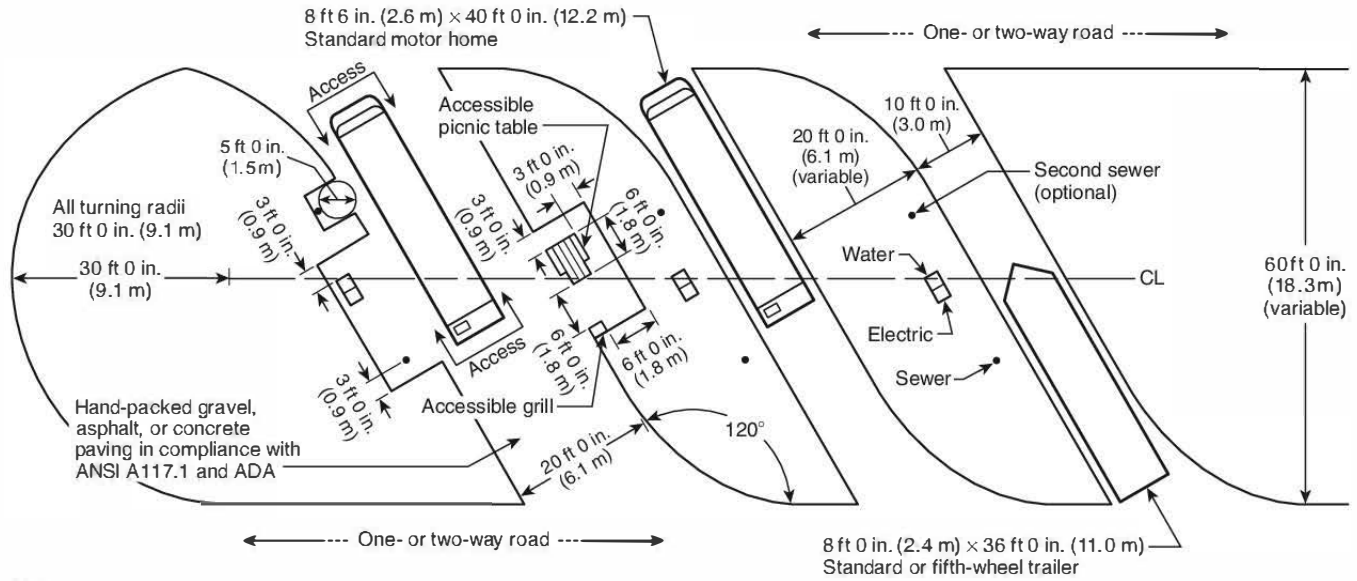

Notes:

1. The utilities are located in the same place as they are in the back-in site.
2. The angle of access and egress should be between 120 degrees and 135 degrees.

Pull-Through Site

FIGURE B.1(e) Optional Arrangement for an Accessible Recreational Vehicle Park or Campground Reverse Pull-Through Site.

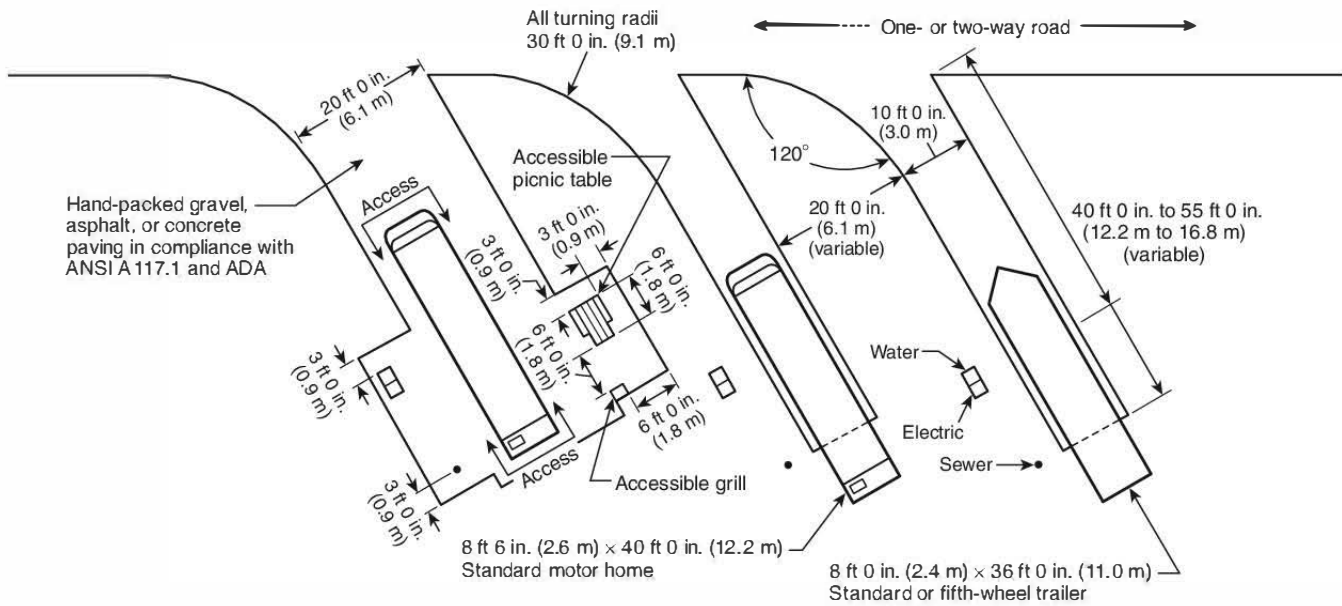

Notes:

1. The utilities are located in the same place as they are in the back-in/park trailer site.
2. The angle of access and egress should be between 120 degrees and 135 degrees.

Back-In Site

FIGURE B.1(f) Optional Arrangement for an Accessible Recreational Vehicle Park or Campground Back-In Site for a Recreational Vehicle Park Trailer.

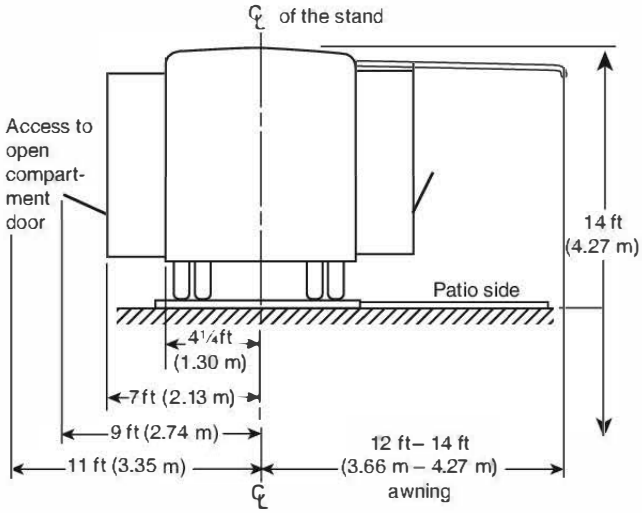

Note: These dimensions are approximate and can vary depending on the recreational vehicle design.

FIGURE B.1(g) End View of Arrangement for Recreational Vehicle Park Trailer.

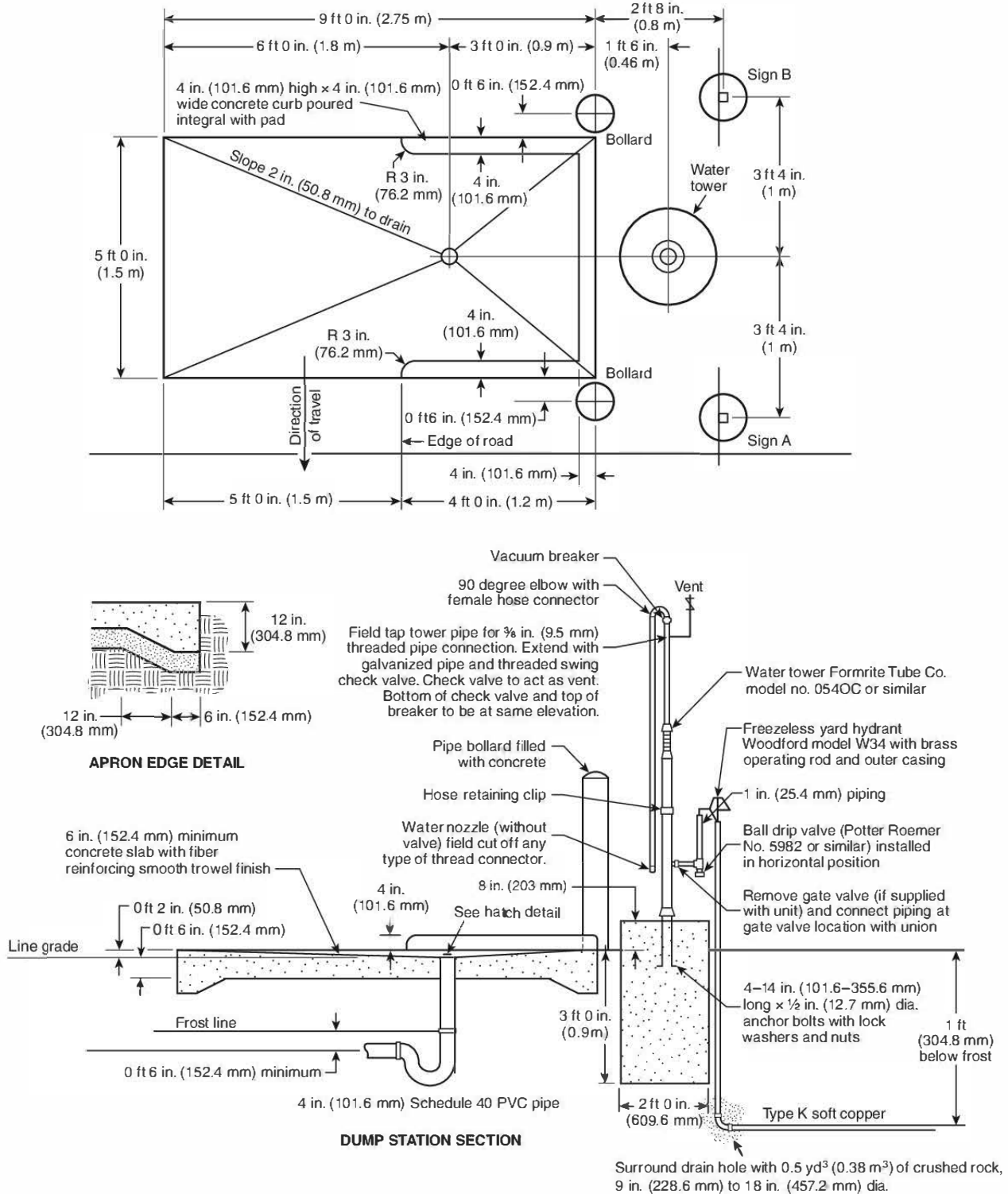

FIGURE B.1(h) Optional Arrangement f for a Sanitary Disposal Station on a Recreational Vehicle Park or Campground.

Annex C Glossary

The following terms or portions thereof are not used within this standard but are listed here for informational purposes only and thus are not considered part of the requirements of this document.

C.1 Accessory Structure. Any structure maintained within recreational vehicle parks or campgrounds that serves the camping unit. Accessory structures are not attached to the camping unit and typically contain no plumbing or electrical fixtures.

C.2 Accessory Structure/Storage. A structure located on a camping unit site that is designed and used solely for the storage and use of personal equipment and possessions of the RVer or camper and could include storage structures and greenhouses.

C.3 Accessory Structures/Uses. Offices, employee or operator living units, recreational facilities, grocery stores, convenience stores, gift shops, service structures, restrooms, dumping stations, showers, laundry facilities, storage units, and other support structures customarily a part of a recreational vehicle park or campground operation.

C.4 Add-on Structure. Structure attached to or immediately adjacent to the camping unit that provides additional space or service.

C.5 Awning. A shade supported by posts or columns and partially supported by the camping unit.

C.6 Cabin/Camping. A hard-sided “tent-like” shelter less than 400 ft² (37.2 m²) in area, typically without plumbing, that is designed to facilitate relocation.

C.7 Cabin/Housekeeping. A structure approved by the authority having jurisdiction that provides guests with full-service amenities.

C.8 Camper(s). A person or persons participating in RVing or camping.

C.9 Carport. A structure located within a camping unit site used for parking of vehicles.

C.10 Environmental Protection. Measures employed in the protection or mitigation of the environment during construction such as erosion control, vegetation plantings with noninvasive plants, and similar efforts.

C.11 Environmental Studies. A collection of research necessary to protect the environment and mitigate impacts often required by the authority having jurisdiction.

C.12 Family-Style Bathrooms. If desired, a campground or RV park should construct bathrooms where each room contains one shower, one toilet, and one lavatory in a room that is over 50 ft² (4.6 m²) and is designed for use by an individual or family. Where a series of these rooms are provided in place of separate men’s and women’s rooms, there should also be one room with only a toilet and lavatory provided for every three family-style bathrooms.

C.13 Greenbelt. A strip of land, containing landscape, site obscuring, or other aesthetic features, intended to buffer potentially incompatible uses. Greenbelts might include utilities and other underground facilities but not camping units.

C.14 Guest. An invited visitor to an RV park or campground.

C.15 Liquid Waste (“Gray Water”). Discharge from fixture, appliance, or appurtenance in connection with a plumbing system that does not receive body waste.

C.16 Occupancy. The presence of a camper(s) in a camping unit site for a night.

C.17 Recreational Vehicle/Dependent. A recreational vehicle not containing sanitary facilities with devices for connecting to a waste disposal system.

C.18 Recreational Vehicle/Independent. A recreational vehicle containing sanitary facilities with devices for connecting to a waste disposal system. This type of recreational vehicle is also referred to as a self-contained recreational vehicle.

C.19 Recreational Vehicle Park Types.

C.19.1 Destination. A recreational vehicle park or campground containing facilities (e.g., swimming pools, restaurants, golf courses, and planned recreational programs) and catering to RVers or campers that will typically travel extended distances to stay for extended periods (e.g., a weekend, a week, or longer).

C.19.2 Extended Stay. A recreational vehicle park or campground that caters to extended stays, full-timers, and seasonal rather than for short-term accommodations. Extended stay facilities tend to occur in certain geographical areas.

C.19.3 Ownership/Membership and Specialty. A recreational vehicle park or campground where either membership is open to members or owners only or the sites are individually owned. This category also includes recreational vehicle parks or campgrounds that are owned or cater to specific audiences such as religious organizations, equestrian groups, square dancers, clothing optional recreationalists, and so on.

C.19.4 Senior Adult. A recreational vehicle park or campground for the exclusive use of senior individuals 55 years of age or older.

C.19.5 Traveler. A recreational vehicle park or campground where RVers and campers stay for a day or week as an alternative to other types of lodging while traveling or vacationing or to enjoy the local attractions within a given area.

C.20 Rental/On-Site. Camping unit placed within a recreational vehicle park or campground that is available for rental to guests.

C.21 Recreational Facilities. Amenities within RV parks and campgrounds for the purposes of customer enjoyment including sports facilities, equipment for amusement, playground facilities, and swimming pools and spas.

C.22 RVers. Individuals that use a camping unit for RVing and camping including, but not limited to, the categories described in C.22.2 through C.22.7.

C.22.1 RVing. A lifestyle. Traveling and/or living independently where one chooses, camping for the enjoyment of the outdoors — a way of life. Using a camping unit for recreation. Associating with the fraternity of other like individuals. Using a camping unit for its intended purpose.

C.22.2 Daily/Overnighter. RVers and campers that stay for a day or week as an alternative to other types of lodging, typically, travelers, area visitors, or tourists enjoying local attractions.

C.22.3 Extended Stay. RVers and campers that stay in a given recreational vehicle park or campground for an extended period of time. The term *extended stay* is generally used in describing four groups as follows:

- (1) Individuals who have selected a recreationally centered lifestyle and that choose a specific location for a traditional season (“sunbirds” and “snowbirds”).
- (2) Individuals who have selected RVing as interim lodging during temporary transfer to a new locality or while awaiting construction of permanent housing.
- (3) Individuals who frequently relocate for employment purposes.
- (4) Individuals who have selected a recreational vehicle, recreational park trailer, and/or camping unit as a housing alternative for extended periods.

C.22.4 Full Timers. Individuals who have opted, because of the benefits of a recreation-oriented RV lifestyle or for economic reasons, to use their camping unit as their only or primary residence.

C.22.5 Seasonals. Individuals who have chosen to leave their camping units in special storage areas or “on the site” at a specific RV park or campground. Many seasonals leave their camping unit on site for the season and typically occupy their camping units from time to time to enjoy organized recreational programs.

C.22.6 Snowbirds. Snowbirds are mostly RVers who own homes in the snow areas. Many of these individuals migrate from north to South in the winter months and south to north in the spring. Areas of dry and warmer climate are typically sought by the snowbirds for varying periods during the North’s coldest season.

C.22.7 Sunbirds. Sunbirds are RVers who typically own homes in the warmer areas of the states where they spend the winter months, moving north toward cooler climate during the extremely hot summer months. They tend to have travel characteristics similar to those of snowbirds.

C.23 Slideout. An expandable portion of a recreational vehicle or recreational park trailer that increases the width beyond the highway travel mode when extended.

C.24 Submetering. A form of conservation whereby the guest pays for utilities used. Submetering can be for consumption of electricity, gas, water, and sewer.

C.25 Teepee. A cone-shaped tent.

C.26 Tent/Hard Shell. See Section C.6.

C.27 Yurt. A portable structure for lodging specially designed for minimal environmental impact in difficult terrain.

Annex D Operations Guidelines

This annex is not a part of the requirements of this NFPA document but is included for informational purposes only.

D.1 Length of Stay.

D.1.1 General. The length of stay for a transient guest should be market-driven and determined by campground management and not by authorities having jurisdiction.

D.1.2 Transient Guest. The occupant of a camping unit site cannot use the site as a permanent residence or domicile irrespective of the length of stay. A transient guest relationship is established because it is not lasting, enduring, or permanent and not a landlord/tenant relationship.

D.1.3 Landlord/Tenant. A landlord/tenant relationship is not established for transient guests.

D.2 Guest Removal/Ejection.

D.2.1 Campground Owner. The campground owner is the owner or operator of a campground or an agent of such owner or operator.

D.2.2 Written Policies. A campground owner should post written policies in a high traffic area on the campground and on the campground website and distribute to registered guests or visitors on arrival at the campground a written policy on campground curfew, alcohol use, tobacco use, pet policy, and so forth.

D.2.2.1 Signed Written Policy. The campground owner should obtain from the guest or visitor on registration a signed copy of the written policies acknowledging they have agreed to abide by those policies during their stay.

D.2.2.2 Discrimination. A campground owner should not have any policies that discriminate based on race, color, national origin, sex, physical disability, or creed.

D.2.3 Ejection/Removal. A campground owner can eject or remove a person from the campground and notify the appropriate local law enforcement authorities of any person for whom any of the following apply:

- (1) Is not a registered guest or visitor of the campground
- (2) Remains on the campground beyond an agreed-on departure time and date
- (3) Defaults in the payment of any lawfully imposed registration or visitor fee or charge
- (4) Creates a disturbance that denies other persons their right to quiet enjoyment of the campground necessary for the preservation of public peace, health, and safety
- (5) Violates any federal, state, or local law

D.2.4 Trespass. A person who remains on a campground after having been asked to leave by a campground owner for violating any of the written policies can be guilty of trespass, subject to possible penalties, and removed summarily by the campground owner or a law enforcement officer.

D.2.5 Refunds. A person who is removed from a campground can be entitled to a refund of the unused portion of any prepaid fees, less any amount otherwise owed to the campground owner or deducted for damages, which unused portion of prepaid fees may be prorated at a rate that is based on the daily rate charged by the campground owner.

D.3 Park Model RV Transportation Equipment.

D.3.1 Detached transportation equipment, including tongue assembly, axles, wheels, and tires, should remain on the campground either on-site or in on-site storage for future use.

D.3.2 Transportation equipment includes the tongue assembly, axles, wheels, and tires.

Source: Missouri Revised Statutes, 419.090 (L. 2014 S.B. 735).

Annex E Informational References

E.1 Referenced Publications. The documents or portions thereof listed in this annex are referenced within the informational sections of this standard and are not part of the requirements of this document unless also listed in Chapter 2 for other reasons.

E.1.1 NFPA Publications. National Fire Protection Association, 1 Batterymarch Park, Quincy, MA 02169-7471.

NFPA 1144, *Standard for Reducing Structure Ignition Hazards from Wildland Fire*, 2018 edition.

NFPA 1192, *Standard on Recreational Vehicles*, 2021 edition.

NFPA 1600[®], *Standard on Continuity, Emergency, and Crisis Management*, 2019 edition.

E.1.2 Other Publications.

E.1.2.1 ANSI Publications. American National Standards Institute, Inc., 25 West 43rd Street, 4th floor, New York, NY 10036.

ANSI A117.1, *Accessible and Usable Buildings and Facilities*, 2017.

ANSI A119.5, *Park Model Recreational Vehicle Standard*, 2018.

E.1.2.2 Other Publications.

Missouri Revised Statutes, 419.090 (L. 2014 S.B. 735).

E.2 Informational References. The following documents or portions thereof are listed here as informational resources only. They are not a part of the requirements of this document.

E.2.1 APSP Publications. Association of Pool and Spa Professionals, 2111 Eisenhower Avenue, Alexandria, VA 22314.

ANSI/APSP/ICC-1, *Standard for Public Swimming Pools*, 2014.

E.2.2 ASTM Publications. ASTM International, 100 Barr Harbor Drive, P.O. Box C700, West Conshohocken, PA 19428-2959.

ASTM Volume 15.07, *Sports Equipment, Playing Surfaces and Facilities; Pedestrian/Walkway Safety and Footwear; Amusement Rides and Devices; Snow Skiing*, 2017.

ASTM F1346, *Standard Performance Specification for Safety Covers and Labeling Requirements for All Covers for Swimming Pools, Spas, and Hot Tubs*, 2018.

ASTM F1487, *Standard Consumer Safety Performance Specification for Playground Equipment for Public Use*, 2011.

ASTM F2291, *Standard Practice for Design of Amusement Rides and Devices*, 2017.

ASTM F2631, *Standard Practice for Installation of Chain-Link Fence for Outdoor Sports Fields, Sports Courts, and Other Recreational Facilities*, 2007 (withdrawn in 2016).

E.2.3 U.S. DOT Publications. U.S. Government Publishing Office, 732 North Capitol Street, NW, Washington, DC 20401-0001.

Title 23, Code of Federal Regulations, Part 655, "Traffic Operations."

E.3 References for Extracts in Informational Sections.

NFPA 1192, *Standard on Recreational Vehicles*, 2021 edition.

Index

Copyright © 2020 National Fire Protection Association. All Rights Reserved.

The copyright in this index is separate and distinct from the copyright in the document that it indexes. The licensing provisions set forth for the document are not applicable to this index. This index may not be reproduced in whole or in part by any means without the express written permission of NFPA.

- A-
- Accessory Structure**
 - Definition, 3.3.1
- Administration, Chap. 1**
 - Application, 1.3
 - Equivalency, 1.5
 - Purpose, 1.2, A.1.2
 - Retroactivity, 1.4
 - Scope, 1.1
 - Units, 1.6
- Approved**
 - Definition, 3.2.1, A.3.2.1
- Authority Having Jurisdiction (AHJ)**
 - Definition, 3.2.2, A.3.2.2
- C-
- Campground**
 - Definition, 3.3.2
 - Developed Campground
 - Definition, 3.3.2.1
 - Primitive Campground
 - Definition, 3.3.2.2, A.3.3.2.2
 - Semi-Developed Campground
 - Definition, 3.3.2.3
 - Semi-Primitive Campground
 - Definition, 3.3.2.4, A.3.3.2.4
- Camping Unit**
 - Definition, 3.3.3, A.3.3.3
- Camping Unit Site**
 - Definition, 3.3.4
- Camping Unit Stand**
 - Definition, 3.3.5
- D-
- Definitions, Chap. 3**
- Density**
 - Definition, 3.3.6
- E-
- Environmental Health and Sanitation, Chap. 7**
 - Drinking Fountains, 7.4
 - General, 7.1
 - Number, Location, and Arrangement of Toilets, Urinals, and Lavatories, 7.6
 - Potable Water Connections at Individual Sites, 7.3
 - Potable Water Supply and Distribution, 7.2
 - Outlets, 7.2.6
 - Pressure and Volume, 7.2.5
 - Prohibited Connections, 7.2.3
 - Quality, 7.2.1
 - Sources, 7.2.2
 - Storage Tanks, 7.2.7
 - Supply, 7.2.4
 - Wells, Springs, and Similar Sources, 7.2.8
 - Potable Water Supply Stations, 7.10
 - Refuse Disposal, 7.11
 - Sanitary Conveniences, 7.5
 - Sanitary Facilities, 7.5.1
 - Sanitary Disposal Stations, 7.9
 - Construction of Sanitary Disposal Stations, 7.9.3
 - Flushing Facilities, 7.9.4
 - Sewerage Facilities, 7.8
 - Approval and Sewerage Disposal Facilities, 7.8.1
 - Pipe Materials, Sizes, and Installation, 7.8.3
 - Sewer Inlet Connections at Individual Recreational Vehicle and Recreational Park Trailer Sites, 7.8.4
 - Waste Treatment System, 7.8.2
 - Showers, 7.7
- Explanatory Material, Annex A**
- F-
- Fire Safety, Chap. 6**
 - Fire Detection and Alarm Services, 6.1
 - Campfire Locations, 6.1.6
 - Detection Systems in Structures Open to the Public, 6.1.2
 - Evacuation Plan, 6.1.5
 - Fire Extinguishers, 6.1.3
 - Use of Fire Protection Equipment, 6.1.4
 - Water Supplies for Fire Protection, 6.1.1
 - Fire Safety Rules and Regulations for Recreational Vehicle Parks and Campgrounds — Posting of Emergency Information, 6.2
 - Propane Containers, 6.3
- G-
- General Design Criteria for Recreational Vehicle Parks and Campgrounds, Chap. 5**
 - Accessible Camping Unit Site (Stand), 5.5
 - Accessible Tent Pads and Tent Platforms, 5.5.3
 - Clear Ground Space, 5.5.3.2
 - General, 5.5.3.1
 - Height, 5.5.3.6
 - Size, 5.5.3.3
 - Slope, 5.5.3.5
 - Surface, 5.5.3.4
 - Clear Ground Space — Minimum Size and Location, 5.5.4
 - Fire Rings, Grills, Fireplaces, and Woodstoves, 5.5.4.2
 - Picnic Tables, 5.5.4.1
 - Height, 5.5.4.1.1
 - Knee Clearance, 5.5.4.1.3
 - Minimum Required Depth, 5.5.4.1.3.1

- Minimum Required Width, 5.5.4.1.3.2
- Toe Clearance, 5.5.4.1.4
 - Minimum Required Depth, 5.5.4.1.4.1
 - Minimum Required Width, 5.5.4.1.4.2
- Wheelchair Space, 5.5.4.1.2
- Trash and Recycling Receptacles, 5.5.4.3
- Utility and Sewage Hookups, 5.5.4.5
- Water Hydrants, 5.5.4.4
- Parking Spaces Within Accessible Camping Unit Sites, 5.5.2
 - Access Aisle, 5.5.2.5
 - Clear Space, 5.5.2.6
 - Other Vehicles, 5.5.2.2
 - Recreational Vehicles, 5.5.2.1
 - Slope, 5.5.2.4
 - Surface, 5.5.2.3
- Camping Unit Site, 5.4
- Park Design and Construction, 5.1
 - Camping Unit Site Size, 5.1.5
 - Gates, 5.1.9
 - Roads, 5.1.2
 - Dead Ends, 5.1.2.5; A.5.1.2.5
 - Turning Radius, 5.1.2.6
 - Separation, 5.1.6
 - Site Identification, 5.1.7
 - Site Plans for Recreational Vehicle Parks and Developed Campgrounds, 5.1.1
 - Bridges, 5.1.1.6
 - Stand, 5.1.8; A.5.1.8
 - Structures, 5.1.3
 - Swimming and Bathing Facilities, 5.1.4
- Recreational Park Trailer Site, 5.3
 - Grouped Utility Connection Assembly, 5.3.2
 - Recreational Park Trailer Stand Construction, 5.3.1
- Recreational Vehicle Site, 5.2
 - Grouped Utility Connection Assembly for Back-In Sites, 5.2.2
 - Grouped Utility Connection Assembly Pull-Through Sites, 5.2.3
 - Recreation Vehicle Stand Construction, 5.2.1
- General Requirements, Chap. 4**
 - Differing Standards, 4.1
 - Electrical Requirements, 4.3
 - U.S. Federal Regulations, 4.2
 - Wildland/Urban Interface Areas, 4.4
- Glossary, Annex C**
 - Accessory Structure, C.1
 - Accessory Structure/Storage, C.2
 - Accessory Structures/Uses, C.3
 - Add-on Structure, C.4
 - Awning, C.5
 - Cabin/Camping, C.6
 - Cabin/Housekeeping, C.7
 - Camper(s), C.8
 - Carport, C.9
 - Environmental Protection, C.10
 - Environmental Studies, C.11
 - Family-Style Bathrooms, C.12
 - Greenbelt, C.13
 - Guest, C.14
 - Liquid Waste ("Gray Water"), C.15
 - Occupancy, C.16
 - Recreational Facilities, C.21
 - Recreational Vehicle Park Types, C.19
 - Destination, C.19.1
 - Extended Stay, C.19.2
 - Ownership/Membership and Specialty, C.19.3
 - Senior Adult, C.19.4
 - Traveler, C.19.5
 - Recreational Vehicle/Dependent, C.17
 - Recreational Vehicle/Independent, C.18
 - Rental/On-Site, C.20
 - RVers, C.22
 - Daily/Overnighter, C.22.2
 - Extended Stay, C.22.3
 - Full Timers, C.22.4
 - RVing, C.22.1
 - Seasonals, C.22.5
 - Snowbirds, C.22.6
 - Sunbirds, C.22.7
 - Slideout, C.23
 - Submetering, C.24
 - Teepee, C.25
 - Tent/Hard Shell, C.26
 - Yurt, C.27
- Gross Trailer Area**
 - Definition, 3.3.7; A.3.3.7
- I-**
- Informational References, Annex E**
- L-**
- Labeled**
 - Definition, 3.2.3
- Listed**
 - Definition, 3.2.4; A.3.2.4
- O-**
- Offset (Sewer Lines)**
 - Definition, 3.3.8
- Operations Guidelines, Annex D**
 - Guest Removal/Ejection, D.2
 - Campground Owner, D.2.1
 - Ejection/Removal, D.2.3
 - Refunds, D.2.5
 - Trespass, D.2.4
 - Written Policies, D.2.2
 - Discrimination, D.2.2.2
 - Signed Written Policy, D.2.2.1
 - Length of Stay, D.1
 - General, D.1.1
 - Landlord/Tenant, D.1.3
 - Transient Guest, D.1.2
 - Park Model RV Transportation Equipment, D.3

-P-

Park Model Recreational Vehicle (also known as Recreational Park Trailer or Park Model RV)

Definition, 3.3.9, A.3.3.9

Park Model RV Site

Definition, 3.3.10

Park Model RV Stand

Definition, 3.3.11

Propane (Liquefied Petroleum Gas, LP-Gas, LPG)

Definition, 3.3.12

Public Water Supply

Definition, 3.3.13

-R-

Rear of Site

Definition, 3.3.14

Recreational Unit Site

Definition, 3.3.15

Recreational Vehicle (RV)

Definition, 3.3.16, A.3.3.16

Recreational Vehicle Park

Definition, 3.3.17, A.3.3.17

Recreational Vehicle Site

Definition, 3.3.18

Recreational Vehicle Stand

Definition, 3.3.19

Referenced Publications, Chap. 2

-S-

Sanitary Disposal Station

Definition, 3.3.20

Service Structure

Definition, 3.3.21, A.3.3.21

Sewage

Definition, 3.3.22

Sewer Branch

Definition, 3.3.23

Sewer Lateral

Definition, 3.3.24

Sewer Main

Definition, 3.3.25

Shall

Definition, 3.2.5

Should

Definition, 3.2.6

Stand

Definition, 3.3.26

Standard

Definition, 3.2.7

-T-

Typical Recreational Vehicle Park or Campground Site Plans, Annex B

-U-

Utility Connection Assembly

Definition, 3.3.27

-W-

Water Riser Pipe

Definition, 3.3.28

Water Supply Station

Definition, 3.3.29