

NFPA® 2001

Standard on Clean Agent Fire Extinguishing Systems

2008 Edition



NFPA, 1 Batterymarch Park, Quincy, MA 02169-7471
An International Codes and Standards Organization

IMPORTANT NOTICES AND DISCLAIMERS CONCERNING NFPA DOCUMENTS

NOTICE AND DISCLAIMER OF LIABILITY CONCERNING THE USE OF NFPA DOCUMENTS

NFPA codes, standards, recommended practices, and guides, of which the document contained herein is one, are developed through a consensus standards development process approved by the American National Standards Institute. This process brings together volunteers representing varied viewpoints and interests to achieve consensus on fire and other safety issues. While the NFPA administers the process and establishes rules to promote fairness in the development of consensus, it does not independently test, evaluate, or verify the accuracy of any information or the soundness of any judgments contained in its codes and standards.

The NFPA disclaims liability for any personal injury, property or other damages of any nature whatsoever, whether special, indirect, consequential or compensatory, directly or indirectly resulting from the publication, use of, or reliance on this document. The NFPA also makes no guaranty or warranty as to the accuracy or completeness of any information published herein.

In issuing and making this document available, the NFPA is not undertaking to render professional or other services for or on behalf of any person or entity. Nor is the NFPA undertaking to perform any duty owed by any person or entity to someone else. Anyone using this document should rely on his or her own independent judgment or, as appropriate, seek the advice of a competent professional in determining the exercise of reasonable care in any given circumstances.

The NFPA has no power, nor does it undertake, to police or enforce compliance with the contents of this document. Nor does the NFPA list, certify, test or inspect products, designs, or installations for compliance with this document. Any certification or other statement of compliance with the requirements of this document shall not be attributable to the NFPA and is solely the responsibility of the certifier or maker of the statement.

ADDITIONAL NOTICES AND DISCLAIMERS

Updating of NFPA Documents

Users of NFPA codes, standards, recommended practices, and guides should be aware that these documents may be superseded at any time by the issuance of new editions or may be amended from time to time through the issuance of Tentative Interim Amendments. An official NFPA document at any point in time consists of the current edition of the document together with any Tentative Interim Amendments and any Errata then in effect. In order to determine whether a given document is the current edition and whether it has been amended through the issuance of Tentative Interim Amendments or corrected through the issuance of Errata, consult appropriate NFPA publications such as the National Fire Codes® Subscription Service, visit the NFPA website at www.nfpa.org, or contact the NFPA at the address listed below.

Interpretations of NFPA Documents

A statement, written or oral, that is not processed in accordance with Section 6 of the Regulations Governing Committee Projects shall not be considered the official position of NFPA or any of its Committees and shall not be considered to be, nor be relied upon as, a Formal Interpretation.

Patents

The NFPA does not take any position with respect to the validity of any patent rights asserted in connection with any items which are mentioned in or are the subject of NFPA codes, standards, recommended practices, and guides, and the NFPA disclaims liability for the infringement of any patent resulting from the use of or reliance on these documents. Users of these documents are expressly advised that determination of the validity of any such patent rights, and the risk of infringement of such rights, is entirely their own responsibility.

NFPA adheres to applicable policies of the American National Standards Institute with respect to patents. For further information contact the NFPA at the address listed below.

Law and Regulations

Users of these documents should consult applicable federal, state, and local laws and regulations. NFPA does not, by the publication of its codes, standards, recommended practices, and guides, intend to urge action that is not in compliance with applicable laws, and these documents may not be construed as doing so.

Copyrights

This document is copyrighted by the NFPA. It is made available for a wide variety of both public and private uses. These include both use, by reference, in laws and regulations, and use in private self-regulation, standardization, and the promotion of safe practices and methods. By making this document available for use and adoption by public authorities and private users, the NFPA does not waive any rights in copyright to this document.

Use of NFPA documents for regulatory purposes should be accomplished through adoption by reference. The term "adoption by reference" means the citing of title, edition, and publishing information only. Any deletions, additions, and changes desired by the adopting authority should be noted separately in the adopting instrument. In order to assist NFPA in following the uses made of its documents, adopting authorities are requested to notify the NFPA (Attention: Secretary, Standards Council) in writing of such use. For technical assistance and questions concerning adoption of NFPA documents, contact NFPA at the address below.

For Further Information

All questions or other communications relating to NFPA codes, standards, recommended practices, and guides and all requests for information on NFPA procedures governing its codes and standards development process, including information on the procedures for requesting Formal Interpretations, for proposing Tentative Interim Amendments, and for proposing revisions to NFPA documents during regular revision cycles, should be sent to NFPA headquarters, addressed to the attention of the Secretary, Standards Council, NFPA, 1 Batterymarch Park, P.O. Box 9101, Quincy, MA 02269-9101.

For more information about NFPA, visit the NFPA website at www.nfpa.org.

Copyright © 2007 National Fire Protection Association®. All Rights Reserved.

NFPA® 2001

Standard on

Clean Agent Fire Extinguishing Systems

2008 Edition

This edition of NFPA 2001, *Standard on Clean Agent Fire Extinguishing Systems*, was prepared by the Technical Committee on Gaseous Fire Extinguishing Systems and acted on by NFPA at its June Association Technical Meeting held June 3-7, 2007, in Boston, MA. It was issued by the Standards Council on July 26, 2007, with an effective date of August 15, 2007, and supersedes all previous editions.

This edition of NFPA 2001 was approved as an American National Standard on August 15, 2007.

Origin and Development of NFPA 2001

The Technical Committee on Halon Alternative Protection Options was organized in 1991 and immediately started work to address the new total flooding clean agents that were being developed to replace Halon 1301. A need existed for an explanation of how to design, install, maintain, and operate systems using these new clean agents, and NFPA 2001 was established to address this need. The 1994 edition was the first edition of NFPA 2001. This standard was revised in 1996, 2000, and 2004.

In January 2005, the technical committees responsible for NFPA 12, NFPA 12A, and NFPA 2001 were combined into the Technical Committee on Gaseous Fire Extinguishing Systems to better address and resolve issues among those documents. This action is intended to facilitate correlation and consistency as requested by the U.S. Environmental Protection Agency.

The 2008 edition has added requirements for local application systems.

Technical Committee on Gaseous Fire Extinguishing Systems

Jeffrey L. Harrington, *Chair*
Harrington Group, Inc., GA [SE]

- Ronald C. Adcock**, Marsh USA Inc., AZ [I]
Maurizio Barbuzzi, North American Fire Guardian Technology, Inc., Italy [M]
Douglas J. Barylski, U.S. Department of the Navy, DC [E]
John E. Dellogono, Liberty Mutual Property, MA [I]
Rep. Property Casualty Insurers Association of America
Todd A. Dillon, Swiss Re, Global Asset Protection Services, OH [I]
William A. Eckholm, Firetrace International, AZ [M]
Dale R. Edlbeck, Tyco Safety Products/Ansul Inc., WI [M]
Don A. Enslow, BP Exploration Alaska, AK [U]
William A. Froh, U.S. Department of Energy, DC [U]
Matthew T. Gustafson, U.S. Social Security Administration, MD [U]
Howard S. Hammel, DuPont Fluoroproducts, DE [M]
Christopher P. Hanauska, Hughes Associates, Inc., MD [SE]
Paul F. Helweg, Jr., Global Risk Consultants Corporation, RI [SE]
Robert H. Kelly, Fire Defense Equipment Company Inc., MI [IM]
Rep. Fire Suppression Systems Association
James L. Kidd, The Hiller Companies, MA [IM]
Norbert W. Makowka, National Association of Fire Equipment Distributors, IL [IM]
Rep. National Association of Fire Equipment Distributors

- Bella A. Maranion**, U.S. Environmental Protection Agency, DC [E]
Robert G. Richard, Honeywell, Inc., NY [M]
Paul E. Rivers, 3M Fire Protection, MN [M]
Patrick W. Schoening, General Motors Corporation, MI [U]
Joseph A. Senecal, Kidde-Fenwal, Inc., MA [M]
Blake M. Shugarman, Underwriters Laboratories Inc., IL [RT]
Clifford R. Sinopoli, II, Exelon Corporation, PA [U]
Rep. Edison Electric Institute
Louise C. Speitel, U.S. Federal Aviation Administration, NJ [E]
Brad T. Stilwell, Fike Corporation, MO [M]
Al Thornton, Chemtura, TX [M]
Klaus Wahle, U.S. Coast Guard, DC [E]
Fred K. Walker, U.S. Department of the Air Force, FL [E]
Robert T. Wickham, Wickham Associates, NH [SE]
Thomas J. Wysocki, Guardian Services, Inc., IL [SE]
Jiann C. Yang, U.S. National Institute of Standards and Technology, MD [RT]

Alternates

- Philip B. Atteberry**, Chemtura, IL [M]
(Alt. to A. Thornton)
Charles O. Baurth, Liberty Mutual Property, MA [I]
(Alt. to J. E. Dellogono)
Philip J. DiNenno, Hughes Associates, Inc., MD [SE]
(Alt. to C. P. Hanauska)
Randall Eberly, U.S. Coast Guard, DC [E]
(Alt. to K. Wahle)
Raymond N. Hansen, U.S. Department of the Air Force, FL [E]
(Alt. to F. K. Walker)
Mark E. Herzog, The Hiller Companies, AL [IM]
(Alt. to J. L. Kidd)
William Matt Hogan, Duke Power Company, SC [U]
(Alt. to C. R. Sinopoli, II)
Daniel J. Hubert, Kidde/Chemetron Fire Systems, IL [M]
(Alt. to J. A. Senecal)
Mary P. Hunstad, U.S. Department of the Navy, DC [E]
(Alt. to D. J. Barylski)
Giuliano Indovino, North American Fire Guardian Technology, Inc., Italy [M]
(Alt. to M. Barbuzzi)
Robert Kasiski, FM Approvals/FM Global, RI [I]
(Voting Alt. to FM Rep.)
- Richard A. Malady**, Fire Fighter Sales and Service Company, PA [IM]
(Alt. to N. W. Makowka)
Earl D. Nearingth, Fike Corporation, MO [M]
(Alt. to B. T. Stilwell)
Ivan M. Nibur, Global Risk Consultants Corporation, KY [SE]
(Alt. to P. F. Helweg, Jr.)
Steven W. Rhodes, U.S. Social Security Administration, MD [U]
(Alt. to M. T. Gustafson)
Mark L. Robin, DuPont Fluoroproducts, DE [M]
(Alt. to H. S. Hammel)
James M. Rucci, Harrington Group, Inc., GA [SE]
(Alt. to J. L. Harrington)
Margaret A. Sheppard, U.S. Environmental Protection Agency, DC [E]
(Alt. to B. A. Maranion)
John C. Spalding, Healey Fire Protection, Inc., MI [IM]
(Alt. to R. H. Kelly)
George Unger, Underwriters' Laboratories of Canada, Canada [RT]
(Alt. to B. M. Shugarman)

Nonvoting

- Rudolf Klitte**, Ginge-Kerr Danmark A/S, Denmark [M]
Ingeborg Schlosser, VdS Schadenverhuetung, Germany [I]
- Fernando Vigara**, APICI, Spain [SE]

David R. Hague, NFPA Staff Liaison

This list represents the membership at the time the Committee was balloted on the final text of this edition. Since that time, changes in the membership may have occurred. A key to classifications is found at the back of the document.

NOTE: Membership on a committee shall not in and of itself constitute an endorsement of the Association or any document developed by the committee on which the member serves.



Committee Scope: This Committee shall have primary responsibility for documents on the installation, maintenance, and use of carbon dioxide systems for fire protection. This Committee shall also have primary responsibility for documents on fixed fire extinguishing systems utilizing bromotrifluoromethane and other similar halogenated extinguishing agents, covering the installation, maintenance, and use of systems.

This Committee shall also have primary responsibility for documents on alternative protection options to Halon 1301 and 1211 fire extinguishing systems. It shall not deal with design, installation, operation, testing, and maintenance of systems employing dry chemical, wet chemical, foam, aerosols, or water as the primary extinguishing media.

Contents

Chapter 1 Administration	2001- 5	Chapter 7 Inspection, Testing, Maintenance, and Training	2001- 19
1.1 Scope	2001- 5	7.1 Inspection and Tests	2001- 19
1.2 Purpose	2001- 5	7.2 Container Test	2001- 20
1.3 Units	2001- 5	7.3 Hose Test	2001- 20
1.4 General Information	2001- 5	7.4 Enclosure Inspection	2001- 20
1.5 Safety	2001- 6	7.5 Maintenance.	2001- 20
1.6 Environmental Factors	2001- 8	7.6 Training	2001- 20
1.7 Retrofitability	2001- 8	7.7 Approval of Installations	2001- 20
1.8 Compatibility with Other Agents	2001- 8	7.8 Safety	2001- 22
Chapter 2 Referenced Publications	2001- 8	Chapter 8 Marine Systems	2001- 22
2.1 General	2001- 8	8.1 General	2001- 22
2.2 NFPA Publications	2001- 8	8.2 Use and Limitations	2001- 22
2.3 Other Publications	2001- 8	8.3 Hazards to Personnel	2001- 22
2.4 References for Extracts in Mandatory Sections	2001- 9	8.4 Agent Supply	2001- 22
Chapter 3 Definitions	2001- 9	8.5 Detection, Actuation, and Control Systems	2001- 23
3.1 General	2001- 9	8.6 Additional Requirements for Systems Protecting Class B Hazards Greater than 6000 ft ³ (170 m ³) with Stored Cylinders Within the Protected Space	2001- 23
3.2 NFPA Official Definitions	2001- 9	8.7 Enclosure	2001- 24
3.3 General Definitions	2001- 9	8.8 Design Concentration Requirements ...	2001- 24
Chapter 4 Components	2001- 10	8.9 Distribution System	2001- 24
4.1 Agent Supply	2001- 10	8.10 Nozzle Choice and Location	2001- 24
4.2 Distribution	2001- 11	8.11 Inspection and Tests	2001- 24
4.3 Detection, Actuation, Alarm, and Control Systems	2001- 13	8.12 Approval of Installations	2001- 25
Chapter 5 System Design	2001- 15	8.13 Periodic Puff Testing	2001- 25
5.1 Specifications, Plans, and Approvals	2001- 15	8.14 Compliance	2001- 25
5.2 System Flow Calculations	2001- 16	Annex A Explanatory Material	2001- 25
5.3 Enclosure	2001- 16	Annex B Cup Burner Method for Determining the Minimum Concentration of Gaseous Agent for Flame Extinguishment	2001- 95
5.4 Design Concentration Requirements ...	2001- 16	Annex C Enclosure Integrity Procedure	2001-106
5.5 Total Flooding Quantity	2001- 17	Annex D Enclosure Evaluation	2001-114
5.6 Duration of Protection.	2001- 18	Annex E Informational References	2001-114
5.7 Distribution System	2001- 18	Index	2001-117
5.8 Nozzle Choice and Location	2001- 18		
Chapter 6 Local Application Systems	2001- 18		
6.1 Description	2001- 18		
6.2 Hazard Specifications	2001- 18		
6.3 Clean Agent Requirements	2001- 19		
6.4 Nozzles	2001- 19		
6.5 Location and Number of Nozzles	2001- 19		
6.6 Operation	2001- 19		

NFPA 2001
Standard on
Clean Agent Fire Extinguishing Systems

2008 Edition

IMPORTANT NOTE: This NFPA document is made available for use subject to important notices and legal disclaimers. These notices and disclaimers appear in all publications containing this document and may be found under the heading "Important Notices and Disclaimers Concerning NFPA Documents." They can also be obtained on request from NFPA or viewed at www.nfpa.org/disclaimers.

NOTICE: An asterisk (*) following the number or letter designating a paragraph indicates that explanatory material on the paragraph can be found in Annex A.

Changes other than editorial are indicated by a vertical rule beside the paragraph, table, or figure in which the change occurred. These rules are included as an aid to the user in identifying changes from the previous edition. Where one or more complete paragraphs have been deleted, the deletion is indicated by a bullet (•) between the paragraphs that remain.

A reference in brackets [] following a section or paragraph indicates material that has been extracted from another NFPA document. As an aid to the user, the complete title and edition of the source documents for extracts in mandatory sections of the document are given in Chapter 2 and those for extracts in informational sections are given in Annex E. Editorial changes to extracted material consist of revising references to an appropriate division in this document or the inclusion of the document number with the division number when the reference is to the original document. Requests for interpretations or revisions of extracted text shall be sent to the technical committee responsible for the source document.

Information on referenced publications can be found in Chapter 2 and Annex E.

Chapter 1 Administration

1.1 Scope. This standard contains minimum requirements for total flooding and local application clean agent fire extinguishing systems. It does not cover fire extinguishing systems that use carbon dioxide or water as the primary extinguishing media, which are addressed by other NFPA documents.

1.2 Purpose.

1.2.1 The agents in this standard were introduced in response to international restrictions on the production of certain halon fire extinguishing agents under the Montreal Protocol signed September 16, 1987, as amended. This standard is prepared for the use and guidance of those charged with purchasing, designing, installing, testing, inspecting, approving, listing, operating, and maintaining engineered or pre-engineered clean agent extinguishing systems, so that such equipment will function as intended throughout its life. Nothing in this standard is intended to restrict new technologies or alternate arrangements provided the level of safety prescribed by this standard is not lowered.

1.2.2 No standard can be promulgated that will provide all the necessary criteria for the implementation of a total flooding clean agent fire extinguishing system. Technology in this area is

under constant development, and this will be reflected in revisions to this standard. The user of this standard must recognize the complexity of clean agent fire extinguishing systems. Therefore, the designer is cautioned that the standard is not a design handbook. The standard does not do away with the need for the engineer or for competent engineering judgment. It is intended that a designer capable of applying a more complete and rigorous analysis to special or unusual problems shall have latitude in the development of such designs. In such cases, the designer is responsible for demonstrating the validity of the approach.

1.3 Units. Metric units of measurement in this standard are in accordance with the modernized metric system known as the International System of Units (SI). Two units (liter and bar), outside of but recognized by SI, are commonly used in international fire protection. These units are listed in Table 1.3 with conversion factors. If a value for measurement as given in this standard is followed by an equivalent value in other units, the first stated is to be regarded as the requirement. A given equivalent value could be approximate.

Table 1.3 Metric Conversion Factors

Name of Unit	Unit Symbol	Conversion Factor
millimeter	mm	1 in. = 25.4 mm
liter	L	1 gal = 3.785 L
cubic meter	m ³	1 ft ³ = 0.028317 m ³
kilogram	kg	1 lb = 0.4536 kg
kilograms per cubic meter	kg/m ³	1 lb/ft ³ = 16.0185 kg/m ³
pascal	Pa	1 psi = 6895 Pa
bar	bar	1 psi = 0.0689 bar
bar	bar	1 bar = 10 ⁵ Pa

Notes:

- (1) For additional conversions and information, see ASTM SI 10.
- (2) In Canada refer to CAN/CSA-Z234.1.

1.4 General Information.

1.4.1* Applicability of Agents.

1.4.1.1 The fire extinguishing agents addressed in this standard shall be electrically nonconducting and leave no residue upon evaporation.

1.4.1.2* Agents that meet the criteria of 1.4.1.1 shall be shown in Table 1.4.1.2.

1.4.1.3 The design, installation, service, and maintenance of clean agent systems shall be performed by those skilled in clean agent fire extinguishing system technology.

1.4.2* Use and Limitations.

1.4.2.1 All pre-engineered systems shall be installed to protect hazards within the limitations that have been established by the listing. Pre-engineered systems shall be listed to one of the following types:

- (1) Those consisting of system components designed to be installed according to pre-tested limitations by a testing laboratory. These pre-engineered systems shall be permitted to incorporate special nozzles, flow rates, methods of application, nozzle placement, and pressurization levels that could differ from those detailed elsewhere in this standard. All other requirements of the standard shall apply.

Table 1.4.1.2 Agents Addressed in NFPA 2001

FK-5-1-12	Dodecafluoro-2-methylpentan-3-one	$\text{CF}_2\text{CF}_2\text{C}(\text{O})\text{CF}(\text{CF}_3)_2$
HCFC Blend A	Dichlorotrifluoroethane	CHCl_2CF_3
	HCFC-123 (4.75%)	
	Chlorodifluoromethane	CHClF_2
	HCFC-22 (82%)	
	Chlorotetrafluoroethane	CHClFCF_3
	HCFC-124 (9.5%)	
	Isopropenyl-1-methylcyclohexene (3.75%)	
HCFC-124	Chlorotetrafluoroethane	CHClFCF_3
HFC-125	Pentafluoroethane	CHF_2CF_3
HFC-227ea	Heptafluoropropane	$\text{CF}_3\text{CH}_2\text{CF}_3$
HFC-23	Trifluoromethane	CHF_3
HFC-236fa	Hexafluoropropane	$\text{CF}_3\text{CH}_2\text{CF}_3$
FIC-131I	Trifluoroiodide	CF_3I
IG-01	Argon	Ar
IG-100	Nitrogen	N_2
IG-541	Nitrogen (52%)	N_2
	Argon (40%)	Ar
	Carbon dioxide (8%)	CO_2
IG-55	Nitrogen (50%)	N_2
	Argon (50%)	Ar
HFC Blend B	Tetrafluoroethane (86%)	$\text{CH}_2\text{F}_2, \text{FCF}_3, \text{CHF}_2,$
	Pentafluoroethane (9%)	CF_3, CO_2
	Carbon dioxide (5%)	

Notes:

(1) Other agents could become available at later dates. They could be added via the NFPA process in future editions of or amendments to the standard.

(2) Composition of inert gas agents are given in percent by volume. Composition of HCFC Blend A is given in percent by weight.

(3) The full analogous ASHRAE nomenclature for FK-5-1-12 is FK-5-1-12mm2.

(2) Automatic extinguishing units incorporating special nozzles, flow rates, methods of application, nozzle placement, actuation techniques, piping materials, discharge times, mounting techniques, and pressurization levels that could differ from those detailed elsewhere in this standard.

1.4.2.2* Clean agents shall not be used on fires involving the following materials unless they have been tested to the satisfaction of the authority having jurisdiction:

- (1) Certain chemicals or mixtures of chemicals, such as cellulose nitrate and gunpowder, which are capable of rapid oxidation in the absence of air
- (2) Reactive metals such as lithium, sodium, potassium, magnesium, titanium, zirconium, uranium, and plutonium
- (3) Metal hydrides
- (4) Chemicals capable of undergoing autothermal decomposition, such as certain organic peroxides and hydrazine

1.4.2.3 Where a total flooding system is used, a fixed enclosure shall be provided about the hazard that allows a specified agent concentration to be achieved and maintained for a specified period of time.

1.4.2.4* The effects of agent decomposition on fire protection effectiveness and equipment shall be considered where using clean agents in hazards with high ambient temperatures (e.g., furnaces and ovens).

1.5 Safety.**1.5.1* Hazards to Personnel.**

1.5.1.1* Any agent that is to be recognized by this standard or proposed for inclusion in this standard shall first be evaluated in a manner equivalent to the process used by the U.S. Environmental Protection Agency's (EPA) SNAP Program.

1.5.1.2* Halocarbon Agents.

1.5.1.2.1* Unnecessary exposure to halocarbon clean agents — including exposure at and below the no observable adverse effects level (NOAEL) — and halocarbon decomposition products shall be avoided. Means shall be provided to limit exposure to no longer than 5 minutes. Unprotected personnel shall not enter a protected space during or after agent discharge. The following additional provisions shall apply:

- (1) Halocarbon systems for spaces that are normally occupied and designed to concentrations up to the NOAEL [see Table 1.5.1.2.1(a)] shall be permitted. The maximum exposure in any case shall not exceed 5 minutes.
- (2) Halocarbon systems for spaces that are normally occupied and designed to concentrations above the NOAEL [see Table 1.5.1.2.1(a)] shall be permitted, given that means be provided to limit exposure to the design concentrations shown in Table 1.5.1.2.1(b) through Table 1.5.1.2.1(e) that correspond to an allowable human exposure time of 5 minutes. Higher design concentrations associated with human exposure times less than 5 minutes as shown in Table 1.5.1.2.1(b) through Table 1.5.1.2.1(e) shall not be permitted in normally occupied spaces. An exposure and egress analysis shall be performed and approved.
- (3) In spaces that are not normally occupied and protected by a halocarbon system designed to concentrations above the lowest observable adverse effects level (LOAEL) [see Table 1.5.1.2.1(a)], and where personnel could possibly be exposed, means shall be provided to limit exposure times using Table 1.5.1.2.1(b) through Table 1.5.1.2.1(e).
- (4) In spaces that are not normally occupied and in the absence of the information needed to fulfill the conditions listed in 1.5.1.2.1(3), the following provisions shall apply:
 - (a) Where egress takes longer than 30 seconds but less than 1 minute, the halocarbon agent shall not be used in a concentration exceeding its LOAEL.
 - (b) Concentrations exceeding the LOAEL are permitted provided that any personnel in the area can escape within 30 seconds.
 - (c) A pre-discharge alarm and time delay shall be provided in accordance with the provisions of 4.3.5.6 of this standard.

1.5.1.3* Inert Gas Clean Agents. Unnecessary exposure to inert gas agent systems resulting in low oxygen atmospheres shall be avoided. The maximum exposure time in any case shall not exceed 5 minutes. See Table 5.5.3.3 for atmospheric correction factors that shall be considered when determining the design concentrations. One objective of pre-discharge alarms and time delays is to prevent human exposure to agents. A pre-discharge alarm and time delay shall be provided in accordance with the provisions of 4.3.5.6 of this standard. Unprotected personnel shall not enter the area during or after agent discharge. The following additional provisions shall apply:



- (1) Inert gas systems designed to concentrations below 43 percent (corresponding to an oxygen concentration of 12 percent, sea level equivalent of oxygen) shall be permitted, where means are provided to limit exposure to no longer than 5 minutes.
- (2) Inert gas systems designed to concentrations between 43 and 52 percent (corresponding to between 12 and 10 percent oxygen, sea level equivalent of oxygen) shall be permitted, where means are provided to limit exposure to no longer than 3 minutes.
- (3) Inert gas systems designed to concentrations between 52 and 62 percent (corresponding to between 10 and 8 percent oxygen, sea level equivalent of oxygen) shall be permitted, given the following:
 - (a) The space is normally unoccupied.
 - (b) Where personnel could possibly be exposed, means are provided to limit the exposure to less than 30 seconds.
- (4) Inert gas systems designed to concentrations above 62 percent (corresponding to 8 percent oxygen or below, sea level equivalent of oxygen) shall only be used in unoccupied areas where personnel are not exposed to such oxygen depletion.

Table 1.5.1.2.1(a) Information for Halocarbon Clean Agents

Agent	NOAEL (%)	LOAEL (%)
FK-5-1-12	10.0	>10.0
HCFC Blend A	10.0	>10.0
HCFC-124	1.0	2.5
HFC-125	7.5	10.0
HFC-227ea	9.0	10.5
HFC-23	30	>30
HFC-236fa	10	15
HFC Blend B*	5.0*	7.5*

*These values are for the largest component of the blend (HFC 134A).

Table 1.5.1.2.1(b) Time for Safe Human Exposure at Stated Concentrations for HFC-125

HFC-125 Concentration		Maximum Permitted Human Exposure Time (min)
% v/v	ppm	
7.5	75,000	5.00
8.0	80,000	5.00
8.5	85,000	5.00
9.0	90,000	5.00
9.5	95,000	5.00
10.0	100,000	5.00
10.5	105,000	5.00
11.0	110,000	5.00
11.5	115,000	5.00
12.0	120,000	1.67
12.5	125,000	0.59
13.0	130,000	0.54
13.5	135,000	0.49

Notes:

- (1) Data derived from the EPA-approved and peer-reviewed physiologically based pharmacokinetic (PBPK) model or its equivalent.
- (2) Based on LOAEL of 10.0 percent in dogs.

Table 1.5.1.2.1(c) Time for Safe Human Exposure at Stated Concentrations for HFC-227ea

HFC-227ea Concentration		Maximum Permitted Human Exposure Time (min)
% v/v	ppm	
9.0	90,000	5.00
9.5	95,000	5.00
10.0	100,000	5.00
10.5	105,000	5.00
11.0	110,000	1.13
11.5	115,000	0.60
12.0	120,000	0.49

Notes:

- (1) Data derived from the EPA-approved and peer-reviewed PBPK model or its equivalent.
- (2) Based on LOAEL of 10.5 percent in dogs.

Table 1.5.1.2.1(d) Time for Safe Human Exposure at Stated Concentrations for HFC-236fa

HFC-236fa Concentration		Maximum Permitted Human Exposure Time (min)
% v/v	ppm	
10.0	100,000	5.00
10.5	105,000	5.00
11.0	110,000	5.00
11.5	115,000	5.00
12.0	120,000	5.00
12.5	125,000	5.00
13.0	130,000	1.65
13.5	135,000	0.92
14.0	140,000	0.79
14.5	145,000	0.64
15.0	150,000	0.49

Notes:

- (1) Data derived from the EPA-approved and peer-reviewed PBPK model or its equivalent.
- (2) Based on LOAEL of 15.0 percent in dogs.

Table 1.5.1.2.1(e) Time for Safe Human Exposure at Stated Concentrations for FIC-131I

FIC-131I Concentration		Maximum Permitted Human Exposure Time (min)
% v/v	ppm	
0.20	2000	5.00
0.25	2500	5.00
0.30	3000	5.00
0.35	3500	4.30
0.40	4000	0.85
0.45	4500	0.49
0.50	5000	0.35

Notes:

- (1) Data derived from the EPA-approved and peer-reviewed PBPK model or its equivalent.
- (2) Based on LOAEL of 0.4 percent in dogs.

1.5.1.4 Safety Requirements.

1.5.1.4.1* Suitable safeguards shall be provided to ensure prompt evacuation of and prevent entry into hazardous atmospheres and also to provide means for prompt rescue of any trapped personnel. Safety items such as personnel training, warning signs, discharge alarms, self-contained breathing apparatus (SCBA), evacuation plans, and fire drills shall be considered.

1.5.1.4.2* Consideration shall be given to the possibility of a clean agent migrating to adjacent areas outside of the protected space.

1.5.1.4.3 For systems protecting occupiable enclosures or spaces where the clean agent design concentration exceeds that approved for use in normally occupied spaces (see Section 1.5), systems shall include the following:

- (1) Supervised system lockout valves
- (2) Pneumatic pre-discharge alarms
- (3) Pneumatic time delays
- (4) Warning signs

1.5.1.4.4* Pneumatic pre-discharge alarms shall be operated by an inert gas. For an inert gas clean agent fire extinguishing system, the quantity of inert gas discharged to operate a pneumatic pre-discharge alarm discharging into the protected space shall be considered, together with the quantity of agent discharged, when making a determination of post-discharge oxygen concentration with respect to compliance with the requirements of 1.5.1.3.

1.5.1.5 All persons who inspect, test, maintain, or operate fire extinguishing systems shall be trained in all aspects of safety related to the systems.

1.5.1.5.1 Before system cylinders are handled or moved, the following steps shall be taken:

- (1) Cylinder outlets shall be fitted with anti-recoil devices, cylinder caps, or both whenever the cylinder outlet is not connected to the system pipe inlet.
- (2) Actuators shall be disabled or removed before cylinders are removed from retaining bracketing.

1.5.1.5.2 Safe handling procedures shall be followed when transporting system cylinders.

1.5.1.5.2.1 Equipment designed for transporting cylinders shall be used. When dollies or carts are used, cylinders shall be secured.

1.5.1.5.2.2 System manufacturer's service procedures shall be followed for specific details on system operation, maintenance, and safety considerations.

1.5.2 Electrical Clearances.

1.5.2.1 All system components shall be located to maintain no less than minimum clearances from energized electrical parts. The following references shall be considered as the minimum electrical clearance requirements for the installation of clean agent systems:

- (1) ANSI C2
- (2) NFPA 70
- (3) 29 CFR 1910, Subpart S

1.5.2.2 Where the design basic insulation level (BIL) is not available, and where nominal voltage is used for the design criteria, the highest minimum clearance listed for this group shall be used.

1.5.2.3 The selected clearance to ground shall satisfy the greater of the switching surge or BIL duty, rather than being based on nominal voltage.

1.5.2.4 The clearance between uninsulated, energized parts of the electrical system equipment and any portion of the clean agent system shall not be less than the minimum clearance provided elsewhere for electrical system insulation on any individual component.

1.5.2.5 Where BIL is not available and where nominal voltage is used for the design criteria, the highest minimum clearance listed for this group shall be used.

1.6* Environmental Factors. When an agent is being selected to protect a hazard area, the effects of the agent on the environment shall be considered. Selection of the appropriate fire suppression agent shall include consideration of the following items:

- (1) Potential environmental effect of a fire in the protected area
- (2) Potential environmental effect of the various agents that could be used

1.7 Retrofitability. Retrofitting of any clean agent into an existing fire extinguishing system shall result in a system that is listed or approved.

1.8 Compatibility with Other Agents.

1.8.1* Mixing of agents in the same container shall be permitted only if the system is listed.

1.8.2 Systems employing the simultaneous discharge of different agents to protect the same enclosed space shall not be permitted.

Chapter 2 Referenced Publications

2.1 General. The documents or portions thereof listed in this chapter are referenced within this standard and shall be considered part of the requirements of this document.

2.2 NFPA Publications. National Fire Protection Association, 1 Batterymarch Park, Quincy, MA 02169-7471.

NFPA 70, *National Electrical Code*[®], 2008 edition.

NFPA 72[®], *National Fire Alarm Code*[®], 2007 edition.

2.3 Other Publications.

2.3.1 ANSI Publications. American National Standards Institute, Inc., 25 West 43rd Street, 4th Floor, New York, NY 10036.

ANSI B1.20.1, *Standard for Pipe Threads, General Purpose*, 1992.

ANSI C2, *National Electrical Safety Code*, 1997.

ANSI Z535, *Standard for Environmental and Facility Safety Signs*, 2002.

2.3.2 ASME Publications. American Society of Mechanical Engineers, Three Park Avenue, New York, NY 10016-5990.

ASME *Boiler and Pressure Vessel Code*, 1998.

ASME B31.1, *Power Piping*, 1998, including B31.1a 1999 Addenda and B31.1b 2000 Addenda.



2.3.3 ASTM Publications. ASTM International, 100 Barr Harbor Drive, P.O. Box C700, West Conshohocken, PA 19428-2959.

ASTM A 120, *Specification for Seamless Carbon Steel Pipe for High Temperature Service*, 1988.

ASTM SI 10, *Standard Practice for Use of the International System of Units (SI): The Modern Metric System*, 1997.

2.3.4 CGA Publications. Compressed Gas Association, 4221 Walney Road, 5th Floor, Chantilly, VA 20151-2923.

CGA C-6, *Standard for Visual Inspection of Steel Compressed Gas Cylinders*, 1993.

2.3.5 CSA Publications. Canadian Standards Association, 5060 Spectrum Way, Suite 100, Mississauga, Ontario L4W 5N6, Canada.

CAN/CSA-Z234.1, *Canadian Metric Practice Guide*, 1989.

2.3.6 IMO Publications. International Maritime Organization, 4 Albert Embankment, London, England, SE1 7SR.

IMO MSC/Circular 848.

2.3.7 ISO Publications. International Organization for Standardization, 1 ch. de la Voie-Creuse, Case postale 56, CH-1211 Geneva 20, Switzerland.

ISO/IEC Guide 7, *Requirements for Standards Suitable for Use for Conformity Assessment*, 1994.

2.3.8 TC Publications. Transport Canada, Tower C, Place de Ville, 330 Sparks Street, Ottawa, Ontario, K1A 0N5.

TP 127, *Ship Safety Electrical Standards*, 2002.

2.3.9 UL Publications. Underwriters Laboratories Inc., 333 Pfingsten Road, Northbrook, IL 60062-2096.

UL 2127, *Standard for Inert Gas Clean Agent Extinguishing System Units*, 2001.

UL 2166, *Standard for Halocarbon Clean Agent Extinguishing System Units*, 2001.

2.3.10 ULC Publications. Underwriters' Laboratories of Canada, 7 Underwriter's Road, Toronto, Ontario M1R 3B4, Canada.

ULC S524-M91, *Standard for the Installation of Fire Alarm Systems*, 1991.

ULC S529-M87, *Smoke Detectors for Fire Alarm Systems*, 1987.

2.3.11 U.S. Government Publications. U.S. Government Printing Office, Washington, DC 20402.

OSHA, Title 29, Code of Federal Regulations, Part 1910, Subpart S.

Title 46, Code of Federal Regulations, Part 72.

Title 46, Code of Federal Regulations, Subchapter J, "Electrical Engineering."

Title 49, Code of Federal Regulations, Parts 170-190, "Transportation."

2.3.12 Other Publications.

Merriam-Webster's Collegiate Dictionary, 11th edition, Merriam-Webster, Inc., Springfield, MA, 2003.

2.4 References for Extracts in Mandatory Sections.

NFPA 12, *Standard on Carbon Dioxide Extinguishing Systems*, 2008 edition.

Chapter 3 Definitions

3.1 General. The definitions contained in this chapter shall apply to the terms used in this standard. Where terms are not defined in this chapter or within another chapter, they shall be defined using their ordinarily accepted meanings within the context in which they are used. *Merriam-Webster's Collegiate Dictionary*, 11th edition, shall be the source for the ordinarily accepted meaning.

3.2 NFPA Official Definitions.

3.2.1* Approved. Acceptable to the authority having jurisdiction.

3.2.2* Authority Having Jurisdiction (AHJ). An organization, office, or individual responsible for enforcing the requirements of a code or standard, or for approving equipment, materials, an installation, or a procedure.

3.2.3* Listed. Equipment, materials, or services included in a list published by an organization that is acceptable to the authority having jurisdiction and concerned with evaluation of products or services, that maintains periodic inspection of production of listed equipment or materials or periodic evaluation of services, and whose listing states that either the equipment, material, or service meets appropriate designated standards or has been tested and found suitable for a specified purpose.

3.2.4 Shall. Indicates a mandatory requirement.

3.2.5 Should. Indicates a recommendation or that which is advised but not required.

3.3 General Definitions.

3.3.1 Adjusted Minimum Design Quantity (AMDQ). The minimum design quantity of agent that has been adjusted in consideration of design factors.

3.3.2 Agent Concentration. The portion of agent in an agent-air mixture expressed in volume percent.

3.3.3 Class A Fire. A fire in ordinary combustible materials, such as wood, cloth, paper, rubber, and many plastics.

3.3.4 Class B Fire. A fire in flammable liquids, combustible liquids, petroleum greases, tars, oils, oil-based paints, solvents, lacquers, alcohols, and flammable gases.

3.3.5 Class C Fire. A fire that involves energized electrical equipment.

3.3.6 Clean Agent. Electrically nonconducting, volatile, or gaseous fire extinguishant that does not leave a residue upon evaporation. The word *agent* as used in this document means clean agent unless otherwise indicated.

3.3.7 Clearance. The air distance between extinguishing system equipment, including piping and nozzles, and unenclosed or uninsulated live electrical components not at ground potential.

3.3.8 Control Room and Electronic Equipment Space. A space containing electronic or electrical equipment, such as that found in control rooms or electronic equipment rooms, where only Class A surface fires or Class C electrical hazards are present.

3.3.9 Design Factor (DF). A fraction of the agent minimum design quantity (MDQ) added thereto deemed appropriate

due to a specific feature of the protection application or design of the suppression system.

3.3.10 Engineered System. A system requiring individual calculation and design to determine the flow rates, nozzle pressures, pipe size, area or volume protected by each nozzle, quantity of agent, and the number and types of nozzles and their placement in a specific system.

3.3.11 Fill Density. Mass of agent per unit of container volume (the customary units are lb/ft³ or kg/m³).

3.3.12 Final Design Quantity (FDQ). The quantity of agent determined from the agent minimum design quantity as adjusted to account for design factors and pressure adjustment.

3.3.13* Halocarbon Agent. An agent that contains as primary components one or more organic compounds containing one or more of the elements fluorine, chlorine, bromine, or iodine.

3.3.14 Inert Gas Agent. An agent that contains as primary components one or more of the gases helium, neon, argon, or nitrogen. Inert gas agents that are blends of gases can also contain carbon dioxide as a secondary component.

3.3.15 Local Application System. A system consisting of a supply of extinguishing agent arranged to discharge directly on the burning material. [12, 2008]

3.3.16 Lockout Valve. A manually operated valve in the discharge pipe between the nozzles and the agent supply that can be locked in the closed position to prevent flow of agent to the protected area.

3.3.17 Lowest Observable Adverse Effect Level (LOAEL). The lowest concentration at which an adverse physiological or toxicological effect has been observed.

3.3.18 Machinery Space. A space containing the main and auxiliary propulsion machinery.

3.3.19 Marine Systems. Systems installed on ships, barges, offshore platforms, motorboats, and pleasure craft.

3.3.20 Minimum Design Quantity (MDQ). The quantity of agent required to achieve the minimum design concentration as calculated using the method in 5.5.1 or 5.5.2, as appropriate.

3.3.21 No Observed Adverse Effect Level (NOAEL). The highest concentration at which no adverse toxicological or physiological effect has been observed.

3.3.22* Normally Occupied Enclosure or Space. An enclosure or space where one or more persons are present under normal conditions.

3.3.23 Occupiable Enclosure or Space. An enclosure or space that has dimensions and physical characteristics such that it could be entered by a person.

3.3.24 Pre-Engineered System. A system having predetermined flow rates, nozzle pressures, and quantities of agent. These systems have the specific pipe size, maximum and minimum pipe lengths, flexible hose specifications, number of fittings, and number and types of nozzles prescribed by a testing laboratory. The hazards protected by these systems are specifically limited as to type and size by a testing laboratory based upon actual fire tests. Limitations on hazards that can be protected by these systems are contained in the manufacturer's installation manual, which is referenced as part of the listing.

3.3.25 Pump Room. A space that contains mechanical equipment for handling, pumping, or transferring flammable or combustible liquids as a fuel.

3.3.26 Safety Factor (SF). A multiplier of the agent flame extinguishing or inerting concentration to determine the agent minimum design concentration.

3.3.27 Sea Level Equivalent of Agent. The agent concentration (volume percent) at sea level for which the partial pressure of agent matches the ambient partial pressure of agent at a given altitude.

3.3.28 Sea Level Equivalent of Oxygen. The oxygen concentration (volume percent) at sea level for which the partial pressure of oxygen matches the ambient partial pressure of oxygen at a given altitude.

3.3.29 Superpressurization. The addition of gas to a fire extinguishing agent container to achieve a specified pressure therein.

3.3.30 Total Flooding. The act and manner of discharging an agent for the purpose of achieving a specified minimum agent concentration throughout a hazard volume.

3.3.31 Total Flooding System. A system consisting of an agent supply and distribution network designed to achieve a total flooding condition in a hazard volume.

Chapter 4 Components

4.1 Agent Supply.

4.1.1 Quantity.

4.1.1.1 Primary Agent Supply. The amount of agent in the system primary agent supply shall be at least sufficient for the largest single hazard to be protected or group of hazards to be protected simultaneously.

4.1.1.2* Reserve Agent Supply. Where required, a reserve agent supply shall consist of as many multiples of the primary agent supply as the authority having jurisdiction considers necessary.

4.1.1.3 Uninterrupted Protection. Where uninterrupted protection is required, both the primary and the reserve agent supplies shall be permanently connected to the distribution piping and arranged for easy changeover.

4.1.2* Quality. Agent properties shall meet the standards of quality given in Table 4.1.2(a) through Table 4.1.2(d). Each batch of agent manufactured shall be tested and certified to the specifications given in the tables. Agent blends shall remain homogeneous in storage and use within the listed temperature range and conditions of service that they will encounter.

Table 4.1.2(a) Halogenated Agent Quality Requirements

Property	Specification
Agent purity, mole %, minimum	99.0
Acidity, ppm (by weight HCl equivalent), maximum	3.0
Water content, weight %, maximum	0.001
Nonvolatile residues, g/100 ml maximum	0.05

Table 4.1.2(b) Inert Gas Agent Quality Requirements

Composition	Gas	IG-01	IG-100	IG-541	IG-55
Composition, % by volume	N ₂		Minimum 99.9%	52% ± 4%	50% ± 5%
	Ar	Minimum 99.9%		40% ± 4%	50% ± 5%
	CO ₂			8% + 1% - 0.0%	
Water content, % by weight		Maximum 0.005%	Maximum 0.005%	Maximum 0.005%	Maximum 0.005%

Table 4.1.2(c) HCFC Blend A Quality Requirements

Component	Amount (weight %)
HCFC-22	82% ± 0.8%
HCFC-124	9.50% ± 0.9%
HCFC-123	4.75% ± 0.5%
Isopropenyl-1- methylcyclohexene	3.75% ± 0.5%

Table 4.1.2(d) HFC Blend B Quality Requirements

Component	Amount (weight %)
HFC-134a	86% ± 5%
HFC-125	9% ± 3%
CO ₂	5% ± 2%

4.1.3 Storage Container Arrangement.

4.1.3.1 Storage containers and accessories shall be located and arranged so that inspection, testing, recharging, and other maintenance activities are facilitated and interruption of protection is held to a minimum.

4.1.3.2* Storage containers shall be located as close as possible to or within the hazard or hazards they protect.

4.1.3.3 Agent storage containers shall not be located where they can be rendered inoperable or unreliable due to mechanical damage or exposure to chemicals or harsh weather conditions or by any other foreseeable cause. Where container exposure to such conditions is unavoidable, then suitable enclosures or protective measures shall be employed.

4.1.3.4 Storage containers shall be securely installed and secured according to the manufacturer's listed installation manual and in a manner that provides for convenient individual servicing or content weighing.

4.1.3.5 Where storage containers are connected to a manifold, automatic means, such as a check valve, shall be provided to prevent agent loss and to ensure personnel safety if the system is operated when any containers are removed for maintenance.

4.1.4 Agent Storage Containers.

4.1.4.1* Storage Containers. Agent shall be stored in containers designed to hold that specific agent at ambient temperatures. Containers shall be charged to a fill density or superpressurization level within the range specified in the manufacturer's listed manual.

4.1.4.2* Each agent container shall have a permanent nameplate or other permanent marking that indicates the following:

- (1) For halocarbon agent containers, the agent, tare and gross weights, and superpressurization level (where applicable) of the container
- (2) For inert gas agent containers, the agent, pressurization level of the container, and nominal agent volume

4.1.4.3 The containers used in these systems shall be designed to meet the requirements of the U.S. Department of Transportation or the Canadian Transport Commission, if used as shipping containers. If not shipping containers, they shall be designed, fabricated, inspected, certified, and stamped in accordance with Section VIII of the ASME *Boiler and Pressure Vessel Code*; independent inspection and certification is recommended. The design pressure shall be suitable for the maximum pressure developed at 130°F (55°C) or at the maximum controlled temperature limit.

4.1.4.4 A reliable means of indication shall be provided to determine the pressure in refillable superpressurized containers.

4.1.4.5 The containers connected to a manifold shall meet the following criteria:

- (1) For halocarbon clean agents in a multiple container system, all containers supplying the same manifold outlet for distribution of the same agent shall be interchangeable and of one select size and charge.
- (2)*Inert gas agents shall be permitted to utilize multiple storage container sizes connected to a common manifold.

4.1.4.6 Storage temperatures shall not exceed or be less than the manufacturer's listed limits. External heating or cooling shall be used to keep the temperature of the storage container within desired ranges.

4.2 Distribution.

4.2.1* Pipe.

4.2.1.1* Pipe shall be noncombustible material having physical and chemical characteristics such that its integrity under stress can be predicted with reliability. Special corrosion-resistant materials or coatings shall be required in severely corrosive atmospheres. The thickness of the piping shall be calculated in accordance with the ASME B31.1, 1998 edition, including B31.1a 1999 Addenda and B31.1b 2000 Addenda. The internal pressure used for this calculation shall not be less than the greater of either of the following values:

- (1) The normal charging pressure in the agent container at 70°F (21°C)
- (2) Eighty percent of the maximum pressure in the agent container at a maximum storage temperature of not less than 130°F (55°C), using the equipment manufacturer's maximum allowable fill density, if applicable

4.2.1.1.1 In no case shall the value used for the minimum pipe design pressure be less than that specified in Table 4.2.1.1.1(a) and Table 4.2.1.1.1(b) for the conditions shown. For inert gas clean agents, Table 4.2.1.1.1(a) shall be used. The pressure-

reducing device shall be readily identifiable. For halocarbon clean agents, Table 4.2.1.1.1(b) shall be used. If different fill densities, pressurization levels, or higher storage temperatures than those shown in Table 4.2.1.1.1(a) or Table 4.2.1.1.1(b) are approved for a given system, the minimum design pressure for the piping shall be adjusted to the maximum pressure in the agent container at maximum temperature, using the basic design criteria specified in 4.2.1.1(1) and 4.2.1.1(2).

4.2.1.2 Other than as allowed in 4.2.1.4, cast-iron pipe, steel pipe conforming to ASTM A 120, or nonmetallic pipe shall not be used.

4.2.1.3 Stenciled pipe identification shall not be painted over, concealed, or removed prior to approval by the authority having jurisdiction.

4.2.1.4 Where used, flexible pipe, flexible nonmetallic pipe, tubing, or hoses, including connections, shall be of approved materials and pressure ratings.

4.2.1.5 Each pipe section shall be cleaned internally after preparation and before assembly by means of swabbing, utilizing a suitable nonflammable cleaner. The pipe network shall be free of particulate matter and oil residue before installation of nozzles or discharge devices.

4.2.1.6* In sections where valve arrangements introduce sections of closed piping, such sections shall be equipped with pressure relief devices, or the valves shall be designed to prevent entrapment of liquid. In systems using pressure-operated container valves, means shall be provided to vent any container leakage that could build up pressure in the pilot system and cause unwanted opening of the container valve. The means of pressure venting shall be arranged so as not to prevent reliable operation of the container valve.

4.2.1.7 All pressure relief devices shall be designed and located so that the discharge from the device will not injure personnel or pose a hazard.

4.2.2 Pipe Joints. Pipe joints other than threaded, welded, brazed, flared, compression, or flanged type shall be listed or approved.

4.2.3 Fittings.

4.2.3.1* Fittings shall have a minimum rated working pressure equal to or greater than the minimum design working pressure specified in 4.2.1.1, for the clean agent being used, or as otherwise listed or approved. For systems that employ the use of a pressure-reducing device in the distribution piping, the fittings downstream of the device shall have a minimum rated working pressure equal to or greater than the maximum anticipated pressure in the downstream piping.

4.2.3.2 Cast-iron fittings shall not be used. Class 150 lb fittings shall not be used unless it can be demonstrated that they comply with the appropriate American National Standards Institute, Inc. (ANSI) stress calculations.

4.2.3.3 All threads used in joints and fittings shall conform to ANSI B1.20.1 or ISO/IEC Guide 7. Joint compound, tape, or thread lubricant shall be applied only to the male threads of the joint.

4.2.3.4 Welding and brazing alloys shall have a melting point above 1000°F (538°C).

4.2.3.5 Welding shall be performed in accordance with Section IX, "Qualification Standard for Welding and Brazing Procedures, Welders, Brazers and Welding and Brazing Operators," of the ASME *Boiler and Pressure Vessel Code*.

4.2.3.6 Where copper, stainless steel, or other suitable tubing is jointed with compression-type fittings, the manufacturer's pressure and temperature ratings of the fitting shall not be exceeded.

4.2.4 Valves.

4.2.4.1 All valves shall be listed or approved for the intended use.

4.2.4.2* All gaskets, o-rings, sealants, and other valve components shall be constructed of materials that are compatible with the agent. Valves shall be protected against mechanical, chemical, or other damage.

4.2.4.3 Special corrosion-resistant materials or coatings shall be used in severely corrosive atmospheres.

Table 4.2.1.1.1(a) Minimum Design Working Pressure for Inert Gas Clean Agent System Piping

Agent	Agent Container Pressure at 70°F (21°C)		Agent Container Pressure at 130°F (55°C)		Minimum Design Pressure at 70°F (21°C) of Piping Upstream of Pressure Reducer	
	psig	kPa	psig	kPa	psig	kPa
IG-01	2370	16,341	2650	18,271	2370	16,341
	2964	20,436	3304	22,781	2964	20,436
IG-541	2175	14,997	2575	17,755	2175	14,997
	2900	19,996	3433	23,671	2900	19,996
IG-55	2222	15,320	2475	17,065	2222	15,320
	2962	20,423	3300	22,753	2962	20,423
IG-100	4443	30,634	4950	34,130	4443	30,634
	2404	16,575	2799	19,299	2404	16,575
	3236	22,312	3773	26,015	3236	22,312
	4061	28,000	4754	32,778	4061	28,000



Table 4.2.1.1.1(b) Minimum Design Working Pressure for Halocarbon Clean Agent System Piping

Agent	Agent Container Maximum Fill Density (lb/ft ³)	Agent Container Charging Pressure at 70°F (21°C) (psi)	Agent Container Pressure at 130°F (55°C) (psi)	Minimum Piping Design Pressure at 70°F (21°C) (psi)
HFC-227ea	79	44*	135	416
	75	150	249	200
	72	360	520	416
	72	600	1025	820
HCFC Blend A	56.2	600	850	680
	56.2	360	540	432
HFC 23	54	608.9†	2182	1746
	48	608.9†	1713	1371
	45	608.9†	1560	1248
	40	608.9†	1382	1106
	35	608.9†	1258	1007
	30	608.9†	1158	927
HCFC-124	74	240	354	283
HCFC-124	74	360	580	464
HFC-125	54	360	615	492
HFC 125	56	600	1045	836
HFC-236fa	74	240	360	280
HFC-236fa	75	360	600	480
HFC-236fa	74	600	1100	880
HFC Blend B	58	360	586	469
	58	600	888	710
FK-5-1-12	90	150†	175	150
	90	195	225	195
	90	360	413	360
	75	500	575	500
	90	610	700	610

*Nitrogen delivered to agent cylinder through a flow restrictor upon system actuation. Nitrogen supply cylinder pressure is 1800 psi at 70°F (21°C).

†Not superpressurized with nitrogen.

4.2.4.4 Where directional valves are used for multi-hazard protection, the directional valves shall be listed or approved for use with the installed suppression system.

4.2.4.5 Where directional valves are used for multi-hazard protection, the control equipment shall be specifically listed for the number, type and operation of those valves.

4.2.5 Discharge Nozzles.

4.2.5.1 Discharge nozzles shall be listed for the intended use. Listing criteria shall include flow characteristics, area coverage, height limits, and minimum pressures. Discharge orifices and discharge orifice plates and inserts shall be of a material that is corrosion resistant to the agent used and the atmosphere in the intended application.

4.2.5.2 Special corrosion-resistant materials or coatings shall be required in severely corrosive atmospheres.

4.2.5.3 Discharge nozzles shall be permanently marked to identify the manufacturer as well as the type and size of the orifice.

4.2.5.4 Where clogging by external foreign materials is likely, discharge nozzles shall be provided with frangible discs, blow-off caps, or other suitable devices. These devices shall provide an unobstructed opening upon system operation and shall be located so they will not injure personnel.

4.3 Detection, Actuation, Alarm, and Control Systems.

4.3.1 General.

4.3.1.1 Detection, actuation, alarm, and control systems shall be installed, tested, and maintained in accordance with appropriate NFPA protective signaling systems standards. (See NFPA 70 and NFPA 72. In Canada refer to ULC S524-M91 and ULC S529-M87.)

4.3.1.2 Automatic detection and automatic actuation shall be used.

4.3.1.2.1 Manual-only actuation shall be permitted if acceptable to the authority having jurisdiction.

4.3.1.3 Initiating and releasing circuits shall be installed in raceways. Other than as permitted in 4.3.1.3.1, alternating current (ac) and direct current (dc) wiring shall not be combined in a common conduit or raceway.

4.3.1.3.1 Ac and dc wiring shall be permitted to be combined in a common conduit or raceway where shielded and grounded.

4.3.2 Automatic Detection.

4.3.2.1* Automatic detection shall be by any listed method or device capable of detecting and indicating heat, flame, smoke, combustible vapors, or an abnormal condition in the hazard, such as process trouble, that is likely to produce fire.

4.3.2.2 Adequate and reliable primary and 24 hour minimum standby sources of energy shall be used to provide for operation of the detection, signaling, control, and actuation requirements of the system.

4.3.2.3 When a new agent system is being installed in a space that has an existing detection system, an analysis shall be made of the detection devices to ensure that the detection system is in good operating condition and will respond promptly to a fire situation. This analysis shall be done to assist in limiting the decomposition products from a suppression event.

4.3.3 Operating Devices.

4.3.3.1 Operating devices shall include agent releasing devices or valves, discharge controls, and shutdown equipment necessary for successful performance of the system.

4.3.3.2 Operation shall be by listed mechanical, electrical, or pneumatic means. An adequate and reliable source of energy shall be used.

4.3.3.3 All devices shall be designed for the service they will encounter and shall not readily be rendered inoperative or susceptible to accidental operation. Devices normally shall be designed to function properly from -20°F to 130°F (-29°C to 54°C) or marked to indicate temperature limitations.

4.3.3.4 All devices shall be located, installed, or suitably protected so that they are not subject to mechanical, chemical, or other damage that would render them inoperative.

4.3.3.5 A means of manual release of the system shall be provided. Manual release shall be accomplished by a mechanical manual release or by an electrical manual release when the control equipment monitors the battery voltage level of the standby battery supply and will provide a low battery signal. The release shall cause simultaneous operation of automatically operated valves controlling agent release and distribution.

4.3.3.5.1* A discharge pressure switch shall be required where mechanical system actuation is possible.

4.3.3.5.2 The discharge pressure switch shall provide an alarm initiating signal to the releasing panel.

4.3.3.6 The normal manual control(s) for actuation shall be located for easy accessibility at all times, including at the time of a fire. The manual control(s) shall be of distinct appearance and clearly recognizable for the purpose intended. Operation of any control shall cause the complete system to operate in its normal fashion.

4.3.3.7 Manual controls shall not require a pull of more than 40 lb (178 N) nor a movement of more than 14 in. (356 mm) to secure operation. At least one manual control for activation shall be located not more than 4 ft (1.2 m) above the floor.

4.3.3.8 Where gas pressure from the system or pilot containers is used as a means for releasing the remaining containers, the supply and discharge rate shall be designed for releasing all of the remaining containers.

4.3.3.9 All devices for shutting down supplementary equipment shall be considered integral parts of the system and shall function with the system operation.

4.3.3.10 All manual operating devices shall be identified as to the hazard they protect.

4.3.4 Control Equipment.

4.3.4.1 Electric Control Equipment. The control equipment shall supervise the actuating devices and associated wiring

and, as required, cause actuation. The control equipment shall be specifically listed for the number and type of actuating devices utilized, and their compatibility shall have been listed.

4.3.4.2 Pneumatic Control Equipment. Where pneumatic control equipment is used, the lines shall be protected against crimping and mechanical damage. Where installations could be exposed to conditions that could lead to loss of integrity of the pneumatic lines, special precautions shall be taken to ensure that no loss of integrity will occur. The control equipment shall be specifically listed for the number and type of actuating devices utilized, and their compatibility shall have been listed.

4.3.5 Operating Alarms and Indicators.

4.3.5.1 Alarms or indicators or both shall be used to indicate the operation of the system, hazards to personnel, or failure of any supervised device. The type (audible, visual, or olfactory), number, and location of the devices shall be such that their purpose is satisfactorily accomplished. The extent and type of alarms or indicator equipment or both shall be approved.

4.3.5.2 Audible and visual pre-discharge alarms shall be provided within the protected area to give positive warning of impending discharge. The operation of the warning devices shall be continued after agent discharge until positive action has been taken to acknowledge the alarm and proceed with appropriate action.

4.3.5.3* Abort switches, where provided, shall be located within the protected area and shall be located near the means of egress for the area. The abort switch shall be of a type that requires constant manual pressure to cause abort. In all cases the normal and manual emergency control shall override the abort function. Operation of the abort function shall result in both audible and distinct visual indication of system impairment. The abort switch shall be clearly recognizable for the purpose intended.

4.3.5.4 Alarms indicating failure of supervised devices or equipment shall give prompt and positive indication of any failure and shall be distinctive from alarms indicating operation or hazardous conditions.

4.3.5.5 Warning and instruction signs at entrances to and inside protected areas shall be provided.

4.3.5.5.1 Warning and safety instruction signs shall be located such that they will be readily visible to personnel in the area where the clean agent design concentration exceeds that approved for use in normally occupied spaces. The safety sign format, color, and the letter style of the signal words shall be in accordance with ANSI Z535.

4.3.5.5.2 Warning and safety instruction signs shall be located outside each entrance to clean agent cylinder storage rooms. The safety sign format, color, and the letter style of the signal words shall be in accordance with ANSI Z535.

4.3.5.6 Time Delays.

4.3.5.6.1* For clean agent extinguishing systems, a pre-discharge alarm and time delay, sufficient to allow personnel evacuation prior to discharge, shall be provided. For hazard areas subject to fast growth fires, where the provision of a time delay would seriously increase the threat to life and property, a time delay shall be permitted to be eliminated.

4.3.5.6.2 Time delays shall be used only for personnel evacuation or to prepare the hazard area for discharge.



4.3.5.6.3 Time delays shall not be used as a means of confirming operation of a detection device before automatic actuation occurs.

4.3.6* Unwanted System Operation. To avoid unwanted discharge of a clean agent system, a supervised disconnect switch shall be provided. The disconnect switch, when operated, shall interrupt the releasing circuit to the suppression system.

Chapter 5 System Design

5.1 Specifications, Plans, and Approvals.

5.1.1 Specifications. Specifications for total flooding and local application clean agent fire extinguishing systems shall be prepared under the supervision of a person fully experienced and qualified in the design of such systems and with the advice of the authority having jurisdiction. The specifications shall include all pertinent items necessary for the proper design of the system, such as the designation of the authority having jurisdiction, variances from the standard to be permitted by the authority having jurisdiction, design criteria, system sequence of operations, the type and extent of the approval testing to be performed after installation of the system, and owner training requirements.

5.1.2 Working Plans.

5.1.2.1 Working plans and calculations shall be submitted for approval to the authority having jurisdiction before system installation or remodeling begins. These documents shall be prepared only by persons fully experienced and qualified in the design of total flooding and local application clean agent fire extinguishing systems. Deviation from these documents shall require permission of the authority having jurisdiction.

5.1.2.2 Working plans shall be drawn to an indicated scale and shall show the following items that pertain to the design of the system:

- (1) Name of owner and occupant.
- (2) Location, including street address.
- (3) Point of compass and symbol legend.
- (4) Location and construction of protected enclosure walls and partitions.
- (5) Location of fire walls.
- (6) Enclosure cross section, full height or schematic diagram, including location and construction of building floor/ceiling assemblies above and below, raised access floor and suspended ceiling.
- (7) Agent being used.
- (8) Design extinguishing or inerting concentration.
- (9) Description of occupancies and hazards being protected, designating whether or not the enclosure is normally occupied.
- (10) For an enclosure protected by a clean agent fire extinguishing system an estimate of the maximum positive and the maximum negative pressure, relative to ambient pressure, expected to be developed upon the discharge of agent.
- (11) Description of exposures surrounding the enclosure.
- (12) Description of the agent storage containers used including internal volume, storage pressure, and nominal capacity expressed in units of agent mass or volume at standard conditions of temperature and pressure.

- (13) Description of nozzle(s) used including size, orifice port configuration, and equivalent orifice area.
- (14) Description of pipe and fittings used including material specifications, grade, and pressure rating.
- (15) Description of wire or cable used including classification, gauge [American Wire Gauge (AWG)], shielding, number of strands in conductor, conductor material, and color coding schedule. Segregation requirements of various system conductors shall be clearly indicated. The required method of making wire terminations shall be detailed.
- (16) Description of the method of detector mounting.
- (17) Equipment schedule or bill of materials for each piece of equipment or device showing device name, manufacturer, model or part number, quantity, and description.
- (18) Plan view of protected area showing enclosure partitions (full and partial height); agent distribution system including agent storage containers, piping, and nozzles; type of pipe hangers and rigid pipe supports; detection, alarm, and control system including all devices and schematic of wiring interconnection between them; end-of-line device locations; location of controlled devices such as dampers and shutters; and location of instructional signage.
- (19) Isometric view of agent distribution system showing the length and diameter of each pipe segment; node reference numbers relating to the flow calculations; fittings including reducers and strainers; and orientation of tees, nozzles including size, orifice port configuration, flow rate, and equivalent orifice area.
- (20) Scale drawing showing the layout of the annunciator panel graphics if required by the authority having jurisdiction.
- (21) Details of each unique rigid pipe support configuration showing method of securement to the pipe and to the building structure.
- (22) Details of the method of container securement showing method of securement to the container and to the building structure.
- (23) Complete step-by-step description of the system sequence of operations, including functioning of abort and maintenance switches, delay timers, and emergency power shutdown.
- (24) Point-to-point wiring schematic diagrams showing all circuit connections to the system control panel and graphic annunciator panel.
- (25) Point-to-point wiring schematic diagrams showing all circuit connections to external or add-on relays.
- (26) Complete calculations to determine enclosure volume, quantity of clean agent, and size of backup batteries and method used to determine number and location of audible and visual indicating devices, and number and location of detectors.
- (27) Details of any special features.
- (28)*Pressure relief vent area, or equivalent leakage area, for the protected enclosure to prevent development, during system discharge, of a pressure difference across the enclosure boundaries that exceeds a specified enclosure pressure limit.

5.1.2.3 The detail on the system shall include information and calculations on the amount of agent; container storage pressure; internal volume of the container; the location, type, and flow rate of each nozzle including equivalent orifice area; the location, size, and equivalent lengths of pipe, fittings, and hose; and the location and size of the storage facility. Pipe size

reduction and orientation of tees shall be clearly indicated. Information shall be submitted pertaining to the location and function of the detection devices, operating devices, auxiliary equipment, and electrical circuitry, if used. Apparatus and devices used shall be identified. Any special features shall be adequately explained.

5.1.2.3.1 Pre-engineered systems shall not be required to specify an internal volume of the container, nozzle flow rates, equivalent lengths of pipe and fitting and hose, or flow calculations, when used within their listed limitations. The information required by the listed system design manual, however, shall be made available to the authority having jurisdiction for verification that the system is within its listed limitations.

5.1.2.4 An “as built” instruction and maintenance manual that includes a full sequence of operations and a full set of drawings and calculations shall be maintained on site.

5.1.2.5 Flow Calculations.

5.1.2.5.1 Flow calculations along with the working plans shall be submitted to the authority having jurisdiction for approval. The version of the flow calculation program shall be identified on the computer calculation printout.

5.1.2.5.2 Where field conditions necessitate any material change from approved plans, the change shall be submitted for approval.

5.1.2.5.3 When such material changes from approved plans are made, corrected “as installed” plans shall be provided.

5.1.3 Approval of Plans.

5.1.3.1 Plans and calculations shall be approved prior to installation.

5.1.3.2 Where field conditions necessitate any significant change from approved plans, the change shall be approved prior to implementation.

5.1.3.3 When such significant changes from approved plans are made, the working plans shall be updated to accurately represent the system as installed.

5.2* System Flow Calculations.

5.2.1* System flow calculations shall be performed using a calculation method listed or approved by the authority having jurisdiction. The system design shall be within the manufacturer’s listed limitations.

5.2.1.1 Designs involving pre-engineered systems shall not be required to be provided with flow calculations in accordance with 5.1.2.5 where used within their listed limitations.

5.2.2 Valves and fittings shall be rated for equivalent length in terms of pipe or tubing sizes with which they will be used. The equivalent length of the container valve shall be listed and shall include siphon tube, valve, discharge head, and flexible connector.

5.2.3 Piping lengths and orientation of fittings and nozzles shall be in accordance with the manufacturer’s listed limitations.

5.2.4 If the final installation varies from the prepared drawings and calculations, new drawings and calculations representing the “as built” installation shall be prepared.

5.3 Enclosure.

5.3.1 In the design of a total flooding system, the characteristics of the protected enclosure shall be considered.

5.3.2 The area of uncloseable openings in the protected enclosure shall be kept to a minimum.

5.3.3 The authority having jurisdiction shall be permitted to require pressurization/depressurization of the protected enclosure or other tests to assure performance meeting the requirements of this standard. (See Annex C.)

5.3.4 To prevent loss of agent through openings to adjacent hazards or work areas, openings shall be permanently sealed or equipped with automatic closures. Where reasonable confinement of agent is not practicable, protection shall be expanded to include the adjacent connected hazards or work areas or additional agent shall be introduced into the protected enclosure using an extended discharge configuration.

5.3.5* Other than the ventilation systems identified in 5.3.5.2, forced-air ventilating systems, including self-contained air recirculation systems, shall be shut down or closed automatically where their continued operation would adversely affect the performance of the fire extinguishing system or result in propagation of the fire.

5.3.5.1 If not shut down or closed automatically, the volume of the self-contained recirculating undamped ventilation system ducts and components mounted below the ceiling height of the protected space shall be considered as part of the total hazard volume when determining the quantity of agent.

5.3.5.2 Ventilation systems necessary to ensure safety shall not be required to be shut down upon activation of the fire suppression system. An extended agent discharge shall be provided to maintain the design concentration for the required duration of protection.

5.3.6* The protected enclosure shall have the structural strength and integrity necessary to contain the agent discharge. If the developed pressures present a threat to the structural strength of the enclosure, venting shall be provided to prevent excessive pressures. Designers shall consult system manufacturer’s recommended procedures relative to enclosure venting. [For pressure relief vent area or equivalent leakage area, see 5.1.2.2(28).]

5.4 Design Concentration Requirements.

5.4.1 The flame extinguishing or inerting concentrations shall be used in determining the agent design concentration for a particular fuel. For combinations of fuels, the flame extinguishment or inerting value for the fuel requiring the greatest concentration shall be used unless tests are made on the actual mixture.

5.4.2* Flame Extinguishment.

5.4.2.1 The flame extinguishing concentration for Class B fuels shall be determined by the cup burner method described in Annex B.

CAUTION: Under certain conditions, it can be dangerous to extinguish a burning gas jet. As a first measure, the gas supply shall be shut off.

5.4.2.2* The flame extinguishing concentration for Class A fuels shall be determined by test as part of a listing program. As a minimum, the listing program shall conform to UL 2127 or UL 2166 or equivalent.

5.4.2.3 The minimum design concentration for a Class B fuel hazard or a manual-only actuated system shall be the extinguishing concentration, as determined in 5.4.2.1, times a safety factor of 1.3.

5.4.2.4* The minimum design concentration for a Class A surface fire hazard shall be the extinguishing concentration, as determined in 5.4.2.2, times a safety factor of 1.2.

5.4.2.5 Minimum design concentration for Class C hazards shall be at least that for Class A surface fire.

5.4.3* Inerting.

5.4.3.1 The inerting concentration shall be determined by test.

5.4.3.2* The inerting concentration shall be used in determining the agent design concentration where conditions for subsequent reflash or explosion exist.

5.4.3.3 The minimum design concentration used to inert the atmosphere of an enclosure where the hazard is a flammable liquid or gas shall be the inerting concentration times a safety factor of 1.1.

5.5 Total Flooding Quantity.

5.5.1* The amount of halocarbon agent required to achieve the design concentration shall be calculated from the following formula:

$$W = \frac{V}{S} \left(\frac{C}{100 - C} \right) \quad (5.5.1)$$

where:

W = weight of clean agent [lb (kg)]

V = net volume of hazard, calculated as the gross volume minus the volume of fixed structures impervious to clean agent vapor [ft³ (m³)]

S = specific volume of the superheated agent vapor at 1 atmosphere and the temperature, t [ft³/lb (m³/kg)]

C = agent design concentration (volume percent)

t = minimum anticipated temperature of the protected volume [°F (°C)]

5.5.1.1 This calculation includes an allowance for the normal leakage from a “tight” enclosure due to agent expansion.

5.5.1.2 Total flooding quantities based on Equation 5.5.1 are given in Table A.5.5.1(a) through Table A.5.5.1(r).

5.5.2* The amount of inert gas agent required to achieve the design concentration shall be calculated using Equation 5.5.2, 5.5.2.1a, or 5.5.2.1b:

$$X = 2.303 \left(\frac{V_s}{s} \right) \text{Log}_{10} \left(\frac{100}{100 - C} \right) \quad (5.5.2)$$

where:

X = volume of inert gas added at standard conditions of 14.7 psia, 70°F (1.013 bar, 21°C) per volume of hazard space [ft³/ft³ (m³/m³)]

V_s = specific volume of inert gas agent at 70°F (21°C) and 14.7 psia (1.013 bar)

s = specific volume of inert gas at 1 atmosphere and the temperature, t [ft³/lb (m³/kg)]

t = minimum anticipated temperature of the protected volume [°F (°C)]

C = inert gas design concentration (volume percent)

5.5.2.1 This calculation includes an allowance for the leakage of agent from a “tight” enclosure. An alternative equation for calculating the inert gas clean agent concentrations shall be as follows:

(5.5.2.1a)

$$X = 2.303 \left(\frac{530}{460 + t} \right) \text{Log}_{10} \left(\frac{100}{100 - C} \right) \text{ where } t \text{ is in } ^\circ\text{F}$$

(5.5.2.1b)

$$X = 2.303 \left(\frac{294.4}{273 + t} \right) \text{Log}_{10} \left(\frac{100}{100 - C} \right) \text{ where } t \text{ is in } ^\circ\text{C}$$

5.5.2.2 Total flooding quantities based on Equations 5.5.2.1a and 5.5.2.1b are given in Table A.5.5.2(a) through Table A.5.5.2(h).

5.5.3* Design Factors. In addition to the concentration requirements, additional quantities of agent are required through the use of design factors to compensate for any special conditions that would affect the extinguishing efficiency.

5.5.3.1* Tee Design Factor. Other than as identified in 5.5.3.1.3, where a single agent supply is used to protect multiple hazards, a design factor from Table 5.5.3.1 shall be applied.

Table 5.5.3.1 Design Factors for Piping Tees

Design Factor Tee Count	Halocarbon Design Factor	Inert Gas Design Factor
0–4	0.00	0.00
5	0.01	0.00
6	0.02	0.00
7	0.03	0.00
8	0.04	0.00
9	0.05	0.01
10	0.06	0.01
11	0.07	0.02
12	0.07	0.02
13	0.08	0.03
14	0.09	0.03
15	0.09	0.04
16	0.10	0.04
17	0.11	0.05
18	0.11	0.05
19	0.12	0.06

5.5.3.1.1 For the application of Table 5.5.3.1, the design factor tee count shall be determined for each hazard the system protects, using the following guidelines:

- (1) Starting from the point where the pipe system enters the hazard, the number of tees in the flow path returning to the agent supply shall be included (do not include tees used in a manifold) in the design factor tee count for the hazard.
- (2) Any tee within the hazard that supplies agent to another hazard shall be included in the design factor tee count for the hazard.

5.5.3.1.2 The hazard with the greatest design factor tee count shall be used in Table 5.5.3.1 to determine the design factor.

5.5.3.1.3 For systems that pass a discharge test, this design factor shall not apply.

5.5.3.2* Additional Design Factors. The designer shall assign and document additional design factors for each of the following:

- (1) Unclosable openings and their effects on distribution and concentration (*see also* 5.8.2)
- (2) Control of acid gases

- (3) Re-ignition from heated surfaces
- (4) Fuel type, configurations, scenarios not fully accounted for in the extinguishing concentration, enclosure geometry, and obstructions and their effects on distribution

5.5.3.3* Design Factor for Enclosure Pressure. The design quantity of the clean agent shall be adjusted to compensate for ambient pressures that vary more than 11 percent [equivalent to approximately 3000 ft (915 m) of elevation change] from standard sea level pressures [29.92 in. Hg at 70°F (760 mm Hg at 0°C)]. (See Table 5.5.3.3.)

Table 5.5.3.3 Atmospheric Correction Factors

Equivalent Altitude		Enclosure Pressure		Atmospheric Correction Factor
ft	km	psia	mm Hg	
-3,000	-0.92	16.25	840	1.11
-2,000	-0.61	15.71	812	1.07
-1,000	-0.30	15.23	787	1.04
0	0.00	14.70	760	1.00
1,000	0.30	14.18	733	0.96
2,000	0.61	13.64	705	0.93
3,000	0.91	13.12	678	0.89
4,000	1.22	12.58	650	0.86
5,000	1.52	12.04	622	0.82
6,000	1.83	11.53	596	0.78
7,000	2.13	11.03	570	0.75
8,000	2.45	10.64	550	0.72
9,000	2.74	10.22	528	0.69
10,000	3.05	9.77	505	0.66

5.6* Duration of Protection. A minimum concentration of 85 percent of the design concentration shall be held at the highest level of combustibles for a minimum period of 10 minutes or for a time period to allow for response by trained personnel. It is important that the agent design concentration not only shall be achieved, but also shall be maintained for the specified period of time to allow effective emergency action by trained personnel. This is equally important in all classes of fires, since a persistent ignition source (e.g., an arc, heat source, oxyacetylene torch, or "deep-seated" fire) can lead to resurgence of the initial event once the clean agent has dissipated.

5.7 Distribution System.

5.7.1 Rate of Application.

5.7.1.1 The minimum design rate of application shall be based on the quantity of agent required for the desired concentration and the time allotted to achieve the desired concentration.

5.7.1.2* Discharge Time.

5.7.1.2.1* For halocarbon agents, the discharge time required to achieve 95 percent of the minimum design concentration for flame extinguishment based on a 20 percent safety factor shall not exceed 10 seconds, or as otherwise required by the authority having jurisdiction.

5.7.1.2.2* For inert gas agents, the discharge time required to achieve 95 percent of the minimum design concentration for flame extinguishment based on a 20 percent safety factor shall not exceed 60 seconds, or as otherwise required by the authority having jurisdiction.

5.7.1.2.3* The discharge time period is defined as the time required to discharge from the nozzles 95 percent of the agent mass [at 70°F (21°C)] necessary to achieve the minimum design concentration based on a 20 percent safety factor for flame extinguishment.

5.7.1.2.4 Flow calculations performed in accordance with Section 5.2, or in accordance with the listed pre-engineered systems instruction manuals, shall be used to demonstrate compliance with 5.7.1.2.

5.7.1.2.5 For explosion prevention systems, the discharge time for agents shall ensure that the minimum inerting design concentration is achieved before concentration of flammable vapors reach the flammable range.

5.7.2* Extended Discharge. When an extended discharge is necessary to maintain the design concentration for the specified period of time, additional agent quantities can be applied at a reduced rate. The initial discharge shall be completed within the limits specified in 5.7.1.2. The performance of the extended discharge system shall be confirmed by test.

5.8 Nozzle Choice and Location.

5.8.1 Nozzles shall be of the type listed for the intended purpose and shall be placed within the protected enclosure in compliance with listed limitations with regard to spacing, floor coverage, and alignment.

5.8.2 The type of nozzles selected, their number, and their placement shall be such that the design concentration will be established in all parts of the hazard enclosure and such that the discharge will not unduly splash flammable liquids or create dust clouds that could extend the fire, create an explosion, or otherwise adversely affect the contents or integrity of the enclosure.

Chapter 6 Local Application Systems

6.1 Description. A local application system shall consist of a fixed supply of clean agent permanently connected to a system of fixed piping with nozzles arranged to discharge directly into the fire.

6.1.1 Uses. Local application systems shall be used for the extinguishment of surface fires in flammable liquids, gases, and shallow solids where the hazard is not enclosed or where the enclosure does not conform to the requirements for total flooding.

6.1.2 General Requirements. Local application systems shall be designed, installed, tested, and maintained in accordance with the applicable requirements of this standard.

6.1.3* Safety Requirements. The safety requirements of Section 1.5 shall apply. During agent discharge, locally high concentrations of the agent will be developed; therefore the requirements of Section 1.5 shall be followed to prevent exposure of personnel to high concentrations of agent.

6.2 Hazard Specifications.

6.2.1 Extent of Hazard. The hazard shall be so isolated from other hazards or combustibles that fire will not spread outside the protected area.

6.2.1.1 The entire hazard shall be protected.



6.2.1.2 The hazard shall include all areas that are or can become coated by combustible liquids or shallow solid coatings, such as areas subject to spillage, leakage, dripping, splashing, or condensation.

6.2.1.3 The hazard shall also include all associated materials or equipment, such as freshly coated stock, drain boards, hoods, ducts, and so forth, that could extend fire outside or lead fire into the protected area.

6.2.1.4 A series of interexposed hazards shall be permitted to be subdivided into smaller groups or sections with the approval of the authority having jurisdiction.

6.2.1.4.1 Systems for such hazards shall be designed to give immediate independent protection to adjacent groups or sections as needed.

6.2.2 Location of Hazard.

6.2.2.1 The hazard shall be permitted to be indoors, partly sheltered, or completely out of doors.

6.2.2.2 It is essential that the clean agent discharge shall be such that winds or strong air currents do not impair the protection. It shall be the responsibility of the system designer to show that such conditions have been taken into account in the design of a system.

6.3 Clean Agent Requirements. The quantity of clean agent required for local application systems shall be based on the rate of discharge and the time that the discharge must be maintained to ensure complete extinguishment. The minimum design quantity shall be no less than 1.5 times the minimum quantity required for extinguishment at any selected system discharge rate.

6.4 Nozzles.

6.4.1 Nozzle Selection. The basis for nozzle selection shall be listed performance data that clearly depicts the interrelationship between agent quantity, discharge rate, discharge time, area coverage, and the distance of the nozzle from the protected surface.

6.4.1.1* The maximum permitted time to extinguish a fire with a halocarbon agent shall be 10 seconds.

6.4.1.2* The maximum permitted time to extinguish a fire with an inert gas agent shall be 30 seconds.

6.4.1.3* Where flammable liquid fires of appreciable depth [over ¼ in. (6 mm)] are to be protected, a minimum freeboard of 6 in. (152 mm) shall be provided unless otherwise noted in approvals or listings of nozzles.

6.4.2 Nozzle Discharge Rates. The design discharge rate through individual nozzles shall be determined on the basis of location or projection distance in accordance with specific approvals or listings.

6.4.2.1 The system discharge rate shall be the sum of the individual rates of all the nozzles and discharge devices used in the system.

6.4.3 Discharge Time. The minimum design discharge time shall be determined by dividing the design quantity by the design rate.

6.4.3.1 The discharge time shall be increased to compensate for any hazard condition that would require a longer cooling period to prevent re-ignition.

6.4.3.2 Where there is a possibility that metal or other material can become heated above the ignition temperature of the fuel, the effective discharge time shall be increased to allow adequate cooling time.

6.4.3.3* Where the fuel has an auto-ignition point below its boiling point, such as paraffin wax and cooking oils, the effective discharge time shall be increased to permit cooling of the fuel to prevent re-ignition.

6.5 Location and Number of Nozzles.

6.5.1* A sufficient number of nozzles shall be used to cover the entire hazard area on the basis of the unit areas protected by each nozzle.

6.5.2 Local application nozzles shall be located in accordance with spacing and discharge rate limitations stated in nozzle listings.

6.5.3 Nozzles shall be located so as to protect coated stock or other hazards extending above a protected surface.

6.5.4* Nozzles shall be located so as to be free of possible obstructions that could interfere with the proper projection of the discharged agent.

6.6* Operation. The system shall be designed for automatic operation except where the authority having jurisdiction permits manual operation.

Chapter 7 Inspection, Testing, Maintenance, and Training

7.1 Inspection and Tests.

7.1.1 At least annually, all systems shall be thoroughly inspected and tested for proper operation by personnel qualified in the installation and testing of clean agent extinguishing systems. Discharge tests shall not be required.

7.1.2 The inspection report with recommendations shall be filed with the owner of the system.

7.1.3 At least semiannually, the agent quantity and pressure of refillable containers shall be checked.

7.1.3.1 For halocarbon clean agents, if a container shows a loss in agent quantity of more than 5 percent or a loss in pressure (adjusted for temperature) of more than 10 percent, it shall be refilled or replaced.

7.1.3.2 For inert gas clean agents that are not liquefied, pressure is an indication of agent quantity. If an inert gas clean agent container shows a loss in pressure (adjusted for temperature) of more than 5 percent, it shall be refilled or replaced. Where container pressure gauges are used for this purpose, they shall be compared to a separate calibrated device at least annually.

7.1.3.3 Where the amount of agent in the container is determined by special measuring devices, these devices shall be listed.

7.1.4* All halocarbon clean agent removed from refillable containers during service or maintenance procedures shall be collected and recycled or disposed of in an environmentally sound manner and in accordance with existing laws and regulations.

7.1.5 Factory-charged, nonrefillable containers that do not have a means of pressure indication shall have the agent quantity checked at least semiannually. If a container shows a loss in

agent quantity of more than 5 percent, it shall be replaced. All factory-charged, nonrefillable containers removed from useful service shall be returned for recycling of the agent or disposed of in an environmentally sound manner and in accordance with existing laws and regulations.

7.1.6 For halocarbon clean agents, the date of inspection, gross weight of cylinder plus agent or net weight of agent, type of agent, person performing the inspection, and, where applicable, the pressure at a recorded temperature shall be recorded on a tag attached to the container. For inert gas clean agents, the date of inspection, type of agent, person performing the inspection, and the pressure at a recorded temperature shall be recorded on a tag attached to the container.

7.2 Container Test.

7.2.1* U.S. Department of Transportation (DOT), Canadian Transport Commission (CTC), or similar design clean agent containers shall not be recharged without retesting if more than 5 years have elapsed since the date of the last test and inspection. For halocarbon agent storage containers, the retest shall be permitted to consist of a complete visual inspection as described in 49 CFR.

7.2.2* Cylinders continuously in service without discharging shall be given a complete external visual inspection every 5 years or more frequently if required. The visual inspection shall be in accordance with Section 3 of CGA C-6, except that the cylinders need not be emptied or stamped while under pressure. Inspections shall be made only by competent personnel, and the results recorded on both of the following:

- (1) A record tag permanently attached to each cylinder
- (2) A suitable inspection report

7.2.2.1 A completed copy of the inspection report shall be furnished to the owner of the system or an authorized representative. These records shall be retained by the owner for the life of the system.

7.2.3 Where external visual inspection indicates that the container has been damaged, additional strength tests shall be required.

7.3 Hose Test.

7.3.1 General. All system hose shall be examined annually for damage. If visual examination shows any deficiency, the hose shall be immediately replaced or tested as specified in 7.3.2.

7.3.2 Testing.

7.3.2.1 All hose shall be tested every 5 years.

7.3.2.2 All hose shall be tested at 1½ times the maximum container pressure at 130°F (54.4°C). The testing procedure shall be as follows:

- (1) The hose is removed from any attachment.
- (2) The hose assembly is then placed in a protective enclosure designed to permit visual observation of the test.
- (3) The hose must be completely filled with water before testing.
- (4) Pressure then is applied at a rate-of-pressure rise to reach the test pressure within a minimum of 1 minute. The test pressure is maintained for 1 full minute. Observations are then made to note any distortion or leakage.
- (5) If the test pressure has not dropped or if the couplings have not moved, the pressure is released. The hose assembly is then considered to have passed the hydrostatic test if no permanent distortion has taken place.

- (6) Hose assembly passing the test must be completely dried internally. If heat is used for drying, the temperature must not exceed the manufacturer's specifications.
- (7) Hose assemblies failing a hydrostatic test must be marked and destroyed and be replaced with new assemblies.
- (8) Each hose assembly passing the hydrostatic test is marked to show the date of test.

7.4 Enclosure Inspection. Other than as identified in 7.4.1, the enclosure protected by the clean agent shall be thoroughly inspected at least every 12 months to determine if penetrations have occurred that could lead to agent leakage or other changes have occurred that could change volume of hazard, or both. Where the inspection indicates conditions that could result in the inability to maintain the clean agent concentration, the conditions shall be corrected. If uncertainty still exists, the enclosures shall be retested for integrity in accordance with 7.7.2.3.

7.4.1 An enclosure inspection shall not be required every 12 months if a documented administrative control program exists that addresses barrier integrity.

7.5* Maintenance.

7.5.1 These systems shall be maintained in full operating condition at all times. Actuation, impairment, and restoration of this protection shall be reported promptly to the authority having jurisdiction.

7.5.2 Any troubles or impairments shall be corrected in a timely manner consistent with the hazard protected.

7.5.3* Any penetrations made through the enclosure protected by the clean agent shall be sealed immediately. The method of sealing shall restore the original fire resistance rating of the enclosure.

7.6 Training.

7.6.1 All persons who could be expected to inspect, test, maintain, or operate fire extinguishing systems shall be thoroughly trained and kept thoroughly trained in the functions they are expected to perform.

7.6.2* Personnel working in an enclosure protected by a clean agent shall receive training regarding agent safety issues.

7.7 Approval of Installations.

7.7.1 General. The completed system shall be reviewed and tested by qualified personnel to meet the approval of the authority having jurisdiction. Only listed equipment and devices shall be used in the systems. To determine that the system has been properly installed and will function as specified, the following tests shall be performed.

7.7.2 Installation Acceptance.

7.7.2.1 General. It shall be determined that the protected enclosure is in general conformance with the construction documents.

7.7.2.2 Review Mechanical Components.

7.7.2.2.1 The piping distribution system shall be inspected to determine that it is in compliance with the design and installation documents.

7.7.2.2.2 Nozzles and pipe size shall be in accordance with system drawings. Means of pipe size reduction and attitudes of tees shall be checked for conformance to the design.



7.7.2.2.3 Piping joints, discharge nozzles, and piping supports shall be securely fastened to prevent unacceptable vertical or lateral movement during discharge. Discharge nozzles shall be installed in such a manner that piping cannot become detached during discharge.

7.7.2.2.4 During assembly, the piping distribution system shall be inspected internally to detect the possibility of any oil or particulate matter soiling the hazard area or affecting the agent distribution due to a reduction in the effective nozzle orifice area.

7.7.2.2.5 The discharge nozzle shall be oriented in such a manner that optimum agent dispersal can be effected.

7.7.2.2.6 If nozzle deflectors are installed, they shall be positioned to obtain maximum benefit.

7.7.2.2.7 The discharge nozzles, piping, and mounting brackets shall be installed in such a manner that they will not potentially cause injury to personnel. Agent shall not directly impinge on areas where personnel could be found in the normal work area. Agent shall not directly impinge on any loose objects or shelves, cabinet tops, or similar surfaces where loose objects could be present and become missiles.

7.7.2.2.8 All agent storage containers shall be properly located in accordance with an approved set of system drawings.

7.7.2.2.9 All containers and mounting brackets shall be fastened securely in accordance with the manufacturer's requirements.

7.7.2.2.10* If a discharge test is to be conducted, containers for the agent to be used shall be weighed before and after discharge. Fill weight of containers shall be verified by weighing or other approved methods. For inert gas clean agents, container pressure shall be recorded before and after discharge.

7.7.2.2.11 Adequate quantity of agent to produce the desired specified concentration shall be provided. The actual room volumes shall be checked against those indicated on the system drawings to ensure the proper quantity of agent. Fan coastdown and damper closure time shall be taken into consideration.

7.7.2.2.12 The piping shall be pneumatically tested in a closed circuit for a period of 10 minutes at 40 psi (276 kPa). At the end of 10 minutes, the pressure drop shall not exceed 20 percent of the test pressure.

7.7.2.2.12.1 The pressure test shall be permitted to be omitted if the total piping contains no more than one change in direction fitting between the storage container and the discharge nozzle, and where all piping is physically checked for tightness.

7.7.2.2.13* A flow test using nitrogen or an inert gas shall be performed on the piping network to verify that flow is continuous and that the piping and nozzles are unobstructed.

7.7.2.3* Review Enclosure Integrity. All total flooding systems shall have the enclosure examined and tested to locate and then effectively seal any significant air leaks that could result in a failure of the enclosure to hold the specified agent concentration level for the specified holding period. The currently preferred method is using a blower door fan unit and smoke pencil. Quantitative results shall be obtained and recorded to indicate that the specified agent concentration for the specified duration of protection is in compliance with Section 5.6, using an approved blower fan unit or other means as approved by the authority having jurisdiction. (*For guidance, see Annex C.*)

7.7.2.4 Review Electrical Components.

7.7.2.4.1 All wiring systems shall be properly installed in compliance with local codes and the system drawings. Alternating current (ac) and direct current (dc) wiring shall not be combined in a common conduit or raceway unless properly shielded and grounded.

7.7.2.4.2 All field circuits shall be free of ground faults and short circuits. Where field circuitry is being measured, all electronic components, such as smoke and flame detectors or special electronic equipment for other detectors or their mounting bases, shall be removed and jumpers shall be properly installed to prevent the possibility of damage within these devices. Components shall be replaced after measuring.

7.7.2.4.3 Power shall be supplied to the control unit from a separate dedicated source that will not be shut down upon system operation.

7.7.2.4.4 Adequate and reliable primary and 24 hour minimum standby sources of energy shall be used to provide for operation of the detection, signaling, control, and actuation requirements of the system.

7.7.2.4.5 All auxiliary functions such as alarm-sounding or displaying devices, remote annunciators, air-handling shutdown, and power shutdown shall be checked for proper operation in accordance with system requirements and design specifications. If possible, all air-handling and power-cutoff controls shall be of the type that, once interrupted, require manual restart to restore power.

7.7.2.4.6 Silencing of alarms, if desirable, shall not affect other auxiliary functions such as air handling or power cutoff if required in the design specification.

7.7.2.4.7 The detection devices shall be checked for proper type and location as specified on the system drawings.

7.7.2.4.8 Detectors shall not be located near obstructions or air ventilation and cooling equipment that would appreciably affect their response characteristics. Where applicable, air changes for the protected area shall be taken into consideration. (*Refer to NFPA 72 and the manufacturer's recommended guidelines.*)

7.7.2.4.9 The detectors shall be installed in a professional manner and in accordance with technical data regarding their installation.

7.7.2.4.10 Manual pull stations shall be properly installed, readily accessible, accurately identified, and properly protected to prevent damage.

7.7.2.4.11 All manual stations used to release agents shall require two separate and distinct actions for operation. They shall be properly identified. Particular care shall be taken where manual release devices for more than one system are in close proximity and could be confused or the wrong system actuated. Manual stations in this instance shall be clearly identified as to which zone or suppression area they affect.

7.7.2.4.12 For systems with a main/reserve capability, the main/reserve switch shall be properly installed, readily accessible, and clearly identified.

7.7.2.4.13 For systems using abort switches, the switches shall be of the deadman type requiring constant manual pressure, properly installed, readily accessible within the hazard area, and clearly identified. Switches that remain in the abort position

when released shall not be used for this purpose. Manual pull stations shall always override abort switches.

7.7.2.4.14 The control unit shall be properly installed and readily accessible.

7.7.2.5 Functional Testing.

7.7.2.5.1 Preliminary Functional Tests. The following preliminary functional tests shall be performed:

- (1) If the system is connected to an alarm receiving office, notify the alarm receiving office that the fire system test is to be conducted and that an emergency response by the fire department or alarm station personnel is not desired. Notify all concerned personnel at the end-user's facility that a test is to be conducted and instruct personnel as to the sequence of operation.
- (2) Disable each agent storage container release mechanism so that activation of the release circuit will not release agent. Reconnect the release circuit with a functional device in lieu of each agent storage container release mechanism. For electrically actuated release mechanisms, these devices can include 24-V lamps, flashbulbs, or circuit breakers. Pneumatically actuated release mechanisms can include pressure gauges. Refer to the manufacturer's recommendations in all cases.
- (3) Check each detector for proper response.
- (4) Check that polarity has been observed on all polarized alarm devices and auxiliary relays.
- (5) Check that all end-of-line resistors have been installed across the detection and alarm bell circuits, where required.
- (6) Check all supervised circuits for proper trouble response.

7.7.2.5.2 System Functional Operational Test. The following system functional operational tests shall be performed:

- (1) Operate detection initiating circuit(s). Verify that all alarm functions occur according to design specifications.
- (2) Operate the necessary circuit to initiate a second alarm circuit, if present. Verify that all second alarm functions occur according to design specifications.
- (3) Operate manual release. Verify that manual release functions occur according to design specifications.
- (4) Operate abort switch circuit, if supplied. Verify that abort functions occur according to design specifications. Confirm that visual and audible supervisory signals are received at the control panel.
- (5) Test all automatic valves, unless testing the valve will release agent or damage the valve (destructive testing).
- (6) Check pneumatic equipment, where required, for integrity to ensure proper operation.

7.7.2.5.3 Remote Monitoring Operations. The following testing of remote monitoring operations, if applicable, shall be performed:

- (1) Operate one of each type of input device while on standby power. Verify that an alarm signal is received at remote panel after device is operated. Reconnect primary power supply.
- (2) Operate each type of alarm condition on each signal circuit and verify receipt of trouble condition at the remote station.

7.7.2.5.4 Control Panel Primary Power Source. The following testing of the control panel primary power source shall be performed:

- (1) Verify that the control panel is connected to a dedicated circuit and labeled properly. This panel shall be readily accessible, yet restricted from unauthorized personnel.

- (2) Test a primary power failure in accordance with the manufacturer's specification with the system fully operated on standby power.

7.7.2.5.5 Return of System to Operational Condition. When all pre-discharge work is completed, each agent storage container shall be reconnected so that activation of the release circuit will release the agent. The system shall be returned to its fully operational design condition. The alarm-receiving office and all concerned personnel at the end-user's facility shall be notified that the fire system test is complete and that the system has been returned to full service condition.

7.8* Safety. Safe procedures shall be observed during installation, servicing, maintenance, testing, handling, and recharging of clean agent systems and agent containers.

Chapter 8 Marine Systems

8.1 General. This chapter outlines the deletions, modifications, and additions that are necessary for marine applications. All other requirements of NFPA 2001 shall apply to shipboard systems except as modified by this chapter. Where the provisions of Chapter 8 conflict with the provisions of Chapters 1 through 7, the provisions of Chapter 8 shall take precedence.

8.1.1 Scope. This chapter is limited to marine applications of clean agent fire extinguishing systems on commercial and government vessels. Explosion inerting systems were not considered during development of this chapter.

8.2 Use and Limitations.

8.2.1* Total flooding clean agent fire extinguishing systems shall be used primarily to protect hazards that are in enclosures or equipment that, in itself, includes an enclosure to contain the agent.

8.2.2* In addition to the limitations given in 1.4.2.2, clean agent fire extinguishing systems shall not be used to protect the following:

- (1) Dry cargo holds
- (2) Bulk cargo

8.2.3 The effects of agent decomposition products and combustion products on fire protection effectiveness and equipment shall be considered where using clean agents in hazards with high ambient temperatures (e.g., incinerator rooms, hot machinery and piping).

8.3 Hazards to Personnel.

8.3.1 Other than the engine rooms identified in 8.3.1.1, all other main machinery spaces shall be considered normally occupied spaces.

8.3.1.1 Engine rooms of 6000 ft³ (170 m³) or less that are accessed for maintenance only shall not be required to comply with 8.3.1.

8.3.2* For marine systems, electrical clearances shall be in accordance with 46 CFR, Subchapter J, "Electrical Engineering."

8.4 Agent Supply.

8.4.1 Reserve quantities of agent shall not be required by this standard.

8.4.2* Storage container arrangement shall be in accordance with 4.1.3.1, 4.1.3.3, 4.1.3.4, and 4.1.3.5. Where equipment is



subject to extreme weather conditions, the system shall be installed in accordance with the manufacturer's design and installation instructions.

8.4.2.1 Except in the case of systems with storage cylinders located within the protected space, pressure containers required for the storage of the agent shall be in accordance with 8.4.2.2.

8.4.2.2 When the agent containers are located outside a protected space, they shall be stored in a room that shall be situated in a safe and readily accessible location and shall be effectively ventilated so that the agent containers are not exposed to ambient temperatures in excess of 130°F (55°C). Common bulkheads and decks located between clean agent container storage rooms and protected spaces shall be protected with A-60 class structural insulation as defined by 46 CFR 72. Agent container storage rooms shall be accessible without having to pass through the space being protected. Access doors shall open outwards, and bulkheads and decks including doors and other means of closing any opening therein, which form the boundaries between such rooms and adjoining spaces, shall be gastight.

8.4.3 Where agent containers are stored in a dedicated space, doors at exits shall swing outward.

8.4.4 Where subject to moisture, containers shall be installed such that a space of at least 2 in. (51 mm) between the deck and the bottom of the container is provided.

8.4.5 In addition to the requirements of 4.1.3.4, containers shall be secured with a minimum of two brackets to prevent movement from vessel motion and vibration.

8.4.6* For marine applications, all piping, valves, and fittings of ferrous materials shall be protected inside and out against corrosion except as permitted in 8.4.6.1.

8.4.6.1 Closed sections of pipe, and valves and fittings within closed sections of pipe, shall only be required to be protected against corrosion on the outside.

8.4.6.2 Other than as permitted in 8.4.6.1, prior to acceptance testing, the inside of the piping shall be cleaned without compromising its corrosion resistance.

8.4.7* Pipes, fittings, nozzles, and hangers, including welding filling materials, within the protected space shall have a melting temperature greater than 1600°F (871°C). Aluminum components shall not be used.

8.4.8 Piping shall extend at least 2 in. (51 mm) beyond the last nozzle in each branch line to prevent clogging.

8.5 Detection, Actuation, and Control Systems.

8.5.1 General.

8.5.1.1 Detection, actuation, alarm, and control systems shall be installed, tested, and maintained in accordance with the requirements of the authority having jurisdiction.

8.5.1.2* For spaces greater than 6000 ft³ (170 m³), automatic release of the fire extinguishing agent shall not be permitted where actuation of the system can interfere with the safe navigation of the vessel. Automatic release of the fire extinguishing agent shall be permitted for any space where actuation of the system will not interfere with the safe navigation of the vessel.

8.5.1.2.1 Automatic release shall be permitted for any space of 6000 ft³ (170 m³) or less.

8.5.2 Automatic Detection.

8.5.2.1 Electrical detection, signaling, control, and actuation system(s) shall have at least two sources of power. The primary source shall be from the vessel's emergency bus. For vessels with an emergency bus or battery, the backup source shall be either the vessel's general alarm battery or an internal battery within the system. Internal batteries shall be capable of operating the system for a minimum of 24 hours. All power sources shall be supervised.

8.5.2.1.1 For vessels without an emergency bus or battery, the primary source shall be permitted to be the main electrical supply.

8.5.2.2 In addition to the requirements set forth in 4.3.3.5, actuation circuits shall not be routed through the protected space where manual electrical actuation is used in marine systems.

8.5.2.2.1 For systems complying with 8.5.2.4, actuation circuits shall be permitted to be routed through the protected space.

8.5.2.3* Manual actuation for systems shall not be capable of being put into operation by any single action. Other than as identified in 8.5.2.3.1, manual actuation stations shall be housed in an enclosure.

8.5.2.3.1 Manual actuation shall be permitted to be local manual actuation at the cylinder(s) location.

8.5.2.4 Systems protecting spaces larger than 6000 ft³ (170 m³) shall have a manual actuation station located in the main egress route outside the protected space. In addition, systems protecting spaces larger than 6000 ft³ (170 m³) having cylinders within the protected space and systems protecting unattended main machinery spaces shall have an actuation station in a continuously monitored control station outside the protected space.

8.5.2.4.1 Systems protecting spaces of 6000 ft³ (170 m³) or less shall be permitted to have a single actuation station at either of the locations described in 8.5.2.4.

8.5.2.5 Emergency lighting shall be provided for remote actuation stations serving systems protecting main machinery spaces. All manual operating devices shall be labeled to identify the hazards they protect. In addition, the following information shall be provided:

- (1) Operating instructions
- (2) Length of time delay
- (3) Actions to take if system fails to operate
- (4) Other actions to take such as closing vents and taking a head count

8.5.2.5.1 For systems having cylinders within the protected space, a means of indicating system discharge shall be provided at the remote actuation station.

8.6 Additional Requirements for Systems Protecting Class B Hazards Greater than 6000 ft³ (170 m³) with Stored Cylinders Within the Protected Space.

8.6.1* An automatic fire detection system shall be installed in the protected space to provide early warning of fire to minimize potential damage to the fire extinguishing system before it can be manually actuated. The detection system shall initiate

audible and visual alarms in the protected space and on the navigating bridge upon detection of fire. All detection and alarm devices shall be electrically supervised for continuity, and trouble indication shall be annunciated on the navigating bridge.

8.6.2* Electrical power circuits connecting the containers shall be monitored for fault conditions and loss of power. Visual and audible alarms shall be provided to indicate this, and these shall be annunciated on the navigating bridge.

8.6.3* Within the protected space, electrical circuits essential for the release of the system shall be heat resistant, such as mineral-insulated cable compliant with Article 330 of NFPA 70, or equivalent. Piping systems essential for the release of systems designed to be operated hydraulically or pneumatically shall be of steel or other equivalent heat-resisting material.

8.6.4* The arrangements of containers and the electrical circuits and piping essential for the release of any system shall be such that in the event of damage to any one power release line through fire or explosion in a protected space (i.e., a single fault concept) the entire fire extinguishing charge required for that space can still be discharged.

8.6.5* The containers shall be monitored for decrease in pressure due to leakage and discharge. Visual and audible signals in the protected area and either on the navigating bridge or in the space where the fire control equipment is centralized shall be provided to indicate a low-pressure condition.

8.6.6* Within the protected space, electrical circuits essential for the release of the system shall be Class A rated in accordance with *NFPA 72*.

8.7 Enclosure.

8.7.1* To prevent loss of agent through openings to adjacent hazards or work areas, openings shall be one of the following designs:

- (1) Permanently sealed
- (2) Equipped with automatic closures
- (3) Equipped with manual closures outfitted with an alarm circuit to indicate when these closures are not sealed upon activation of the system

8.7.1.1 Where confinement of agent is not practical, or if the fuel can drain from one compartment to another, such as via a bilge, protection shall be extended to include the adjacent connected compartment or work areas.

8.7.2* Prior to agent discharge, all ventilating systems shall be closed and isolated to preclude passage of agent to other compartments or the vessel exterior. Automatic shutdowns or manual shutdowns capable of being closed by one person from a position co-located with the agent discharge station shall be used.

8.8 Design Concentration Requirements.

8.8.1 Combinations of Fuels. For combinations of fuels, the design concentration shall be derived from the flame extinguishment value for the fuel requiring the greatest concentration.

8.8.2 Design Concentration. For a particular fuel, the design concentration referred to in 8.8.3 shall be used.

8.8.3 Flame Extinguishment. The minimum design concentration for Class B flammable and combustible liquids shall be as determined following the procedures described in IMO MSC/Circular 848.

8.8.4* Total Flooding Quantity. The quantity of agent shall be based on the net volume of the space and shall be in accordance with the requirements of paragraph 5 of IMO MSC/Circular 848 "Annex."

8.8.5* Duration of Protection. It is important that the agent design concentration not only shall be achieved, but also shall be maintained for a sufficient period of time to allow effective emergency action by trained ship's personnel. In no case shall the hold time be less than 15 minutes.

8.9 Distribution System.

8.9.1 Rate of Application. The minimum design rate of application shall be based on the quantity of agent required for the desired concentration and the time allowed to achieve the desired concentration.

8.9.2 Discharge Time.

8.9.2.1 The discharge time for halocarbon agents shall not exceed 10 seconds or as otherwise required by the authority having jurisdiction.

8.9.2.2 For halocarbon agents, the discharge time period shall be defined as the time required to discharge from the nozzles 95 percent of the agent mass [at 70°F (21°C)] necessary to achieve the minimum design concentration.

8.9.2.3 The discharge time for inert gas agents shall not exceed 120 seconds for 85 percent of the design concentration or as otherwise required by the authority having jurisdiction.

8.10 Nozzle Choice and Location. For spaces other than identified in 8.10.1, nozzles shall be of the type listed for the intended purpose. Limitations shall be determined based on testing in accordance with IMO MSC/Circular 848. Nozzle spacing, area coverage, height, and alignment shall not exceed the limitations.

8.10.1 For spaces having only Class A fuels, nozzle placement shall be in accordance with the nozzles' listed limitations.

8.11 Inspection and Tests. At least annually, all systems shall be thoroughly inspected and tested for proper operation by competent personnel. Discharge tests shall not be required.

8.11.1 An inspection report with recommendations shall be filed with the vessel's master and the owner's agent. The report shall be available for inspection by the authority having jurisdiction.

8.11.2 At least annually, the agent quantity of refillable containers shall be checked by competent personnel. The container pressure shall be verified and logged at least monthly by the vessel's crew.

8.11.3* For halocarbon clean agents, if a container shows a loss in agent of more than 5 percent or a loss in pressure, adjusted for temperature, of more than 10 percent, it shall be refilled or replaced.

8.11.3.1 For inert gas clean agents that are not liquefied, pressure is an indication of agent quantity. If an inert gas clean agent container shows a loss in pressure, adjusted for temperature, of more than 5 percent, it shall be refilled or replaced. Where container pressure gauges are used for this purpose, they shall be compared to a separate calibrated device at least annually.

8.11.4 The installing contractor shall provide instructions for the operational features and inspection procedures specific to the clean agent system installed on the vessel.



8.12 Approval of Installations. Prior to acceptance of the system, technical documentation such as the system design manual, test reports, or listing report shall be presented to the authority having jurisdiction. This documentation shall show that the system and its individual components are compatible, employed within tested limitations, and suitable for marine use.

8.12.1 The listing organization shall perform the following functions:

- (1) Verify that fire tests were conducted in accordance with predetermined standard
- (2) Verify that component tests were conducted in accordance with predetermined standard
- (3) Review the component quality assurance program
- (4) Review the design and installation manual
- (5) Identify system and component limitations
- (6) Verify flow calculations
- (7) Verify the integrity and the reliability of system as a whole
- (8) Have a follow-up program
- (9) Publish a list of equipment

8.13 Periodic Puff Testing. A test in accordance with 7.7.2.2.13 shall be performed at 24 month intervals. The periodic test program shall include a functional test of all alarms, controls, and time delays.

8.14 Compliance. Electrical systems shall be in accordance with 46 CFR Subchapter J, “Electrical Engineering.” For Canadian vessels, electrical installations shall be in accordance with TP 127.

Annex A Explanatory Material

Annex A is not a part of the requirements of this NFPA document but is included for informational purposes only. This annex contains explanatory material, numbered to correspond with the applicable text paragraphs.

A.1.4.1 The agents currently listed possess the physical properties as detailed in Table A.1.4.1 (a) through Table A.1.4.1 (d). This data will be revised from time to time as new information becomes available. Additional background information and data on these agents can be found in several references: Fernandez (1991), Hanauska (1991), Robin (1991), and Sheinson (1991).

A.1.4.1.2 The designations for perfluorocarbons (FCs), hydrochlorofluorocarbons (HCFCs), hydrofluorocarbons (HFCs), fluoriodocarbons (FICs), and fluoroketones (FKs) are an extension of halocarbon designations in ANSI/ASHRAE 34, prepared by the American National Standards Institute, Inc. (ANSI) and the American Society of Heating, Refrigerating and Air Conditioning Engineers, Inc. (ASHRAE). HCFC Blend A is a designation for a blend of HCFCs and a hydrocarbon. The designation IG-541 is used in this standard for a blend of three inert gases — nitrogen, argon, and carbon dioxide (52 percent, 40 percent, and 8 percent, respectively). The designation IG-01 is used in this standard for argon, an unblended inert gas. The designation IG-100 is used in this standard for nitrogen, an unblended inert gas. The designation IG-55 is used in this standard for a blend of two inert gases — nitrogen and argon (50 percent and 50 percent, respectively).

A.1.4.2 Clean agent fire extinguishing systems are useful within the limits of this standard for extinguishing fires in specific hazards or equipment and in occupancies where an elec-

trically nonconductive medium is essential or desirable, or where cleanup of other media presents a problem.

Total flooding clean agent fire extinguishing systems are used primarily to protect hazards that are in enclosures or equipment that, in itself, includes an enclosure to contain the agent. Some typical hazards that could be suitable include, but are not limited to, the following:

- (1) Electrical and electronic hazards
- (2) Subfloors and other concealed spaces
- (3) Flammable and combustible liquids and gases
- (4) Other high-value assets
- (5) Telecommunications facilities

Clean agent systems could also be used for explosion prevention and suppression where flammable materials could collect in confined areas.

A.1.4.2.2 Electrostatic charging of ungrounded conductors could occur during the discharge of liquefied gases. These conductors could discharge to other objects, causing an electric arc of sufficient energy to initiate an explosion.

While an attractive feature of these agents is their suitability for use in environments containing energized electrical equipment without damaging that equipment, in some instances the electrical equipment could be the source of ignition. In such cases, the energized equipment should be de-energized prior to or during agent discharge.

A.1.4.2.4 The provision of an enclosure can create an unnecessary explosion hazard where otherwise only a fire hazard exists. A hazard analysis should be conducted to determine the relative merits of differing design concepts — for example, with and without enclosures — and the most relevant means of fire protection.

This provision provides consideration for using a clean agent in an environment that could result in an inordinate amount of products of decomposition (i.e., within an oven).

See NFPA 77.

A.1.5.1 Potential hazards to be considered for individual systems are the following:

- (1) *Noise.* Discharge of a system can cause noise loud enough to be startling but ordinarily insufficient to cause traumatic injury.
- (2) *Turbulence.* High-velocity discharge from nozzles could be sufficient to dislodge substantial objects directly in the path. System discharge can cause enough general turbulence in the enclosures to move unsecured paper and light objects.
- (3) *Cold Temperature.* Direct contact with the vaporizing liquid being discharged from a system will have a strong chilling effect on objects and can cause frostbite burns to the skin. The liquid phase vaporizes rapidly when mixed with air and thus limits the hazard to the immediate vicinity of the discharge point. In humid atmospheres, minor reduction in visibility can occur for a brief period due to the condensation of water vapor.

A.1.5.1.1 The discharge of clean agent systems to extinguish a fire could create a hazard to personnel from the natural form of the clean agent or from the products of decomposition that result from exposure of the agent to the fire or hot surfaces. Unnecessary exposure of personnel either to the natural agent or to the decomposition products should be avoided.

The SNAP Program was originally outlined in 59 CFR 13044.

Table A.1.4.1(a) Physical Properties of Clean Halocarbon Agents (U.S. Units)

Physical Property	Units	FIC-1311	FK-5-1-12	HCFC Blend A	HFC Blend B	HCFC-124	HFC-125	HFC-227ea	HFC-23	HFC-236fa
Molecular weight	N/A	195.9	316.04	92.9	99.4	136.5	120.0	170	70.01	152
Boiling point at 760 mm Hg	°F	-8.5	120.2	-37	-14.9	10.5	-54	2.4	-115.6	29.5
Freezing point	°F	-166	-162.4	161	-153.9	-326	-153	-204	-247.4	-153.4
Critical temperature	°F	252	335.6	256	219.9	252.5	150.8	214	79.1	256.9
Critical pressure	psi	586	270.44	964	588.9	527	525	424	700	464.1
Critical volume	ft ³ /lbm	0.0184	0.0251	0.028	0.031	0.0286	0.0279	0.0280	0.0304	0.02905
Critical density	lbm/ft ³	54.38	39.91	36	32.17	34.96	35.81	35.77	32.87	34.42
Specific heat, liquid at 77°F	Btu/lb °F	0.141	0.2634	0.3	0.339	0.271	0.354	0.281	0.987 at 68°F	0.3012
Specific heat, vapor at constant pressure (1 atm) and 77°F	Btu/lb °F	0.86	0.2127	0.16	0.203	0.18	0.19	0.193	0.175 at 68°F	0.201
Heat of vaporization at boiling point	Btu/lb	48.1	37.8	97	93.4	71.3	70.5	56.6	103	68.97
Thermal conductivity of liquid at 77°F	Btu/hr ft °F	0.04	0.034	0.052	0.0478	0.0395	0.0343	0.034	0.0305	0.0421
Viscosity, liquid at 77°F	lb/ft hr	0.473	1.27	0.508	0.485	0.622	0.338	0.579	0.107	0.6906
Relative dielectric strength at 1 atm at 734 mm Hg, 77°F (N ₂ = 1)	N/A	1.41	2.3	1.32	1.014	1.55	0.955 at 70°F	2	1.04	1.0166
Solubility of water in agent	wt%	0.01 at 70°F	<0.001 at 70°F	0.12 at 70°F	0.11 at 70°F	770 at 77°F	770 at 77°F	0.06 at 70°F	500 at 50°F	740 at 68°F

Table A.1.4.1(b) Physical Properties of Inert Gas Agents (U.S. Units)

Physical Property	Units	IG-01	IG-100	IG-541	IG-55
Molecular weight	N/A	39.9	28.0	34.0	33.95
Boiling point at 760 mm Hg	°F	-302.6	-320.4	-320	-310.2
Freezing point	°F	-308.9	-346.0	-109	-327.5
Critical temperature	°F	-188.1	-232.4	N/A	-210.5
Critical pressure	psia	711	492.9	N/A	602
Specific heat, vapor at constant pressure (1 atm) and 77°F	Btu/lb °F	0.125	0.445	0.195	0.187
Heat of vaporization at boiling point	Btu/lb	70.1	85.6	94.7	77.8
Relative dielectric strength at 1 atm at 734 mm Hg, 77°F (N ₂ = 1.0)	N/A	1.01	1.0	1.03	1.01
Solubility of water in agent at 77°F	N/A	0.006%	0.0013%	0.015%	0.006%



Table A.1.4.1(c) Physical Properties of Clean Halocarbon Agents (SI Units)

Physical Property	Units			HCFC	HFC						
		FIC-131I	FK-5-1-12	Blend A	Blend B	HCFC-124	HFC-125	HFC-227ea	HFC-23	HFC-236fa	
Molecular weight	N/A	195.91	316.04	92.90	99.4	136.5	120	170	70.01	152	
Boiling point at 760 mm Hg	°C	-22.5	49	-38.3	-26.1	-12.0	-48.1	-16.4	-82.1	-1.4	
Freezing point	°C	-110	-108	<107.2	-103	-198.9	-102.8	-131	-155.2	-103	
Critical temperature	°C	122	168.66	124.4	101.1	122.6	66	101.7	26.1	124.9	
Critical pressure	kPa	4041	1865	6647	4060	3620	3618	2912	4828	3200	
Critical volume	cc/mole	225	494.5	162	198	243	210	274	133	276*	
Critical density	kg/m ³	871	639.1	577	515.3	560	574	621	527	551.3	
Specific heat, liquid at 25°C	kJ/kg °C	0.592	1.103	1.256	1.44	1.153	1.407	1.184	4.130 at 20°C	1.264	
Specific heat, vapor at constant pressure (1 atm) and 25°C	kJ/kg °C	0.3618	0.891	0.67	0.848	0.742	0.797	0.808	0.731 at 20°C	0.840	
Heat of vaporization at boiling point	kJ/kg	112.4	88	225.6	217.2	165.9	164.1	132.6	239.3	160.4	
Thermal conductivity of liquid at 25°C	W/m °C	0.07	0.059	0.09	0.082	0.0684	0.0592	0.069	0.0534	0.0729	
Viscosity, liquid at 25°C	centipoise	0.196	0.524	0.21	0.202	0.257	0.14	0.184	0.044	0.286	
Relative dielectric strength at 1 atm at 734 mm Hg, 25°C (N ₂ = 1.0)	N/A	1.41	2.3	1.32	1.014	1.55	0.955 at 21°C	2	1.04	1.0166	
Solubility of water in agent	ppm	1.0062% by weight	<0.001	0.12% by weight	0.11% by weight	700 at 25°C	700 at 25°C	0.06% by weight	500 at 10°C	740 at 20°C	

Table A.1.4.1(d) Physical Properties of Inert Gas Agents (SI Units)

Physical Property	Units	IG-01	IG-100	IG-541	IG-55
Molecular weight	N/A	39.9	28.0	34.0	33.95
Boiling point at 760 mm Hg	°C	-189.85	-195.8	-196	-190.1
Freezing point	°C	-189.35	-210.0	-78.5	-199.7
Critical temperature	°C	-122.3	-146.9	N/A	-134.7
Critical pressure	kPa	4,903	3,399	N/A	4,150
Specific heat, vapor at constant pressure (1 atm) and 25°C	kJ/kg °C	0.519	1.04	0.574	0.782
Heat of vaporization at boiling point	kJ/kg	163	199	220	181
Relative dielectric strength at 1 atm at 734 mm Hg, 25°C (N ₂ = 1.0)	N/A	1.01	1.0	1.03	1.01
Solubility of water in agent at 25°C	N/A	0.006%	0.0013%	0.015%	0.006%

A.1.5.1.2 Table A.1.5.1.2(a) provides information on the toxicological effects of halocarbon agents covered by this standard. The NOAEL is the highest concentration at which no adverse physiological or toxicological effect has been observed. The LOAEL is the lowest concentration at which an adverse physiological or toxicological effect has been observed.

An appropriate protocol measures the effect in a stepwise manner such that the interval between the LOAEL and NOAEL is sufficiently small to be acceptable to the competent regulatory authority. The EPA includes in its SNAP evaluation this aspect (of the rigor) of the test protocol.

Table A.1.5.1.2(a) Toxicity Information for Halocarbon Clean Agents

Agent	LC ₅₀ or ALC (%)	NOAEL (%)	LOAEL (%)
FIC-131I	>12.8	0.2	0.4
FK-5-1-12	>10.0	10	>10.0
HCFC	64	10	>10.0
Blend A			
HCFC-124	23-29	1	2.5
HFC-125	>70	7.5	10
HFC-227ea	>80	9	10.5
HFC-23	>65	30	>30
HFC-236fa	>45.7	10	15
HFC Blend B	56.7*	5.0*	7.5*

Notes:

(1) LC₅₀ is the concentration lethal to 50 percent of a rat population during a 4 hour exposure. The ALC is the approximate lethal concentration.

(2) The cardiac sensitization levels are based on the observation or non-observation of serious heart arrhythmias in a dog. The usual protocol is a 5 minute exposure followed by a challenge with epinephrine.

(3) High concentration values are determined with the addition of oxygen to prevent asphyxiation.

*These values are for the largest component of the blend (HFCB 134A).

For halocarbons covered in this standard, the NOAEL and LOAEL are based on the toxicological effect known as cardiac sensitization. Cardiac sensitization occurs when a chemical causes an increased sensitivity of the heart to adrenaline, a naturally occurring substance produced by the body during times of stress, leading to the sudden onset of irregular heart beats and possibly heart attack. Cardiac sensitization is measured in dogs after they have been exposed to a halocarbon agent for 5 minutes. At the 5 minute time period, an external dose of adrenaline (epinephrine) is administered and an effect is recorded, if the dog experiences cardiac sensitization. The cardiac sensitization potential as measured in dogs is a highly conservative indicator of the potential in humans. The conservative nature of the cardiac sensitization test stems from several factors; the two most pertinent are as follows:

- (1) Very high doses of adrenaline are given to the dogs during the testing procedure (doses are more than 10 times higher than the highest levels secreted by humans under maximum stress).
- (2) Four to ten times more halocarbon is required to cause cardiac sensitization in the absence of externally administered adrenaline, even in artificially created situations of stress or fright in the dog test.

Because the cardiac sensitization potential is measured in dogs, a means of providing human relevance to the concentration at which this cardiac sensitization occurs (LOAEL) has been established through the use of physiologically based pharmacokinetic (PBPK) modeling.

A PBPK model is a computerized tool that describes time-related aspects of a chemical's distribution in a biological system. The PBPK model mathematically describes the uptake of the halocarbon into the body and the subsequent distribution of the halocarbon to the areas of the body where adverse effects can occur. For example, the model describes the breathing rate and uptake of the halocarbon from the exposure atmosphere into the lungs. From there, the model uses the blood flow bathing the lungs to describe the movement of the halocarbon from the lung space into the arterial blood that directly feeds the heart and vital organs of the body.

It is the ability of the model to describe the halocarbon concentration in human arterial blood that provides its primary utility in relating the dog cardiac sensitization test results to a human who is unintentionally exposed to the halocarbon. The concentration of halocarbon in the dog arterial blood at the time the cardiac sensitization event occurs (5 minute exposure) is the critical arterial blood concentration, and this blood parameter is the link to the human system. Once this critical arterial blood concentration has been measured in dogs, the EPA-approved PBPK model simulates how long it will take the human arterial blood concentration to reach the critical arterial blood concentration (as determined in the dog test) during human inhalation of any particular concentration of the halocarbon agent. As long as the simulated human arterial concentration remains below the critical arterial blood concentration, the exposure is considered safe. Inhaled halocarbon concentrations that produce human arterial blood concentrations equal to or greater than the critical arterial blood concentration are considered unsafe because they represent inhaled concentrations that potentially yield arterial blood concentrations where cardiac sensitization events occur in the dog test. Using these critical arterial blood concentrations of halocarbons as the ceiling for allowable human arterial concentrations, any number of halocarbon exposure scenarios can be evaluated using this modeling approach.

For example, in the dog cardiac sensitization test on Halon 1301, a measured dog arterial blood concentration of 25.7 mg/L is measured at the effect concentration (LOAEL) of 7.5 percent after a 5 minute exposure to Halon 1301 and an external intravenous adrenaline injection. The PBPK model predicts the time at which the human arterial blood concentration reaches 25.7 mg/L for given inhaled Halon 1301 concentrations. Using this approach the model also predicts that at some inhaled halocarbon concentrations, the critical arterial blood concentration is never reached, and thus, cardiac sensitization will not occur. Accordingly, in the tables in 1.5.1.2.1, the time is arbitrarily truncated at 5 minutes, because the dogs were exposed for 5 minutes in the original cardiac sensitization testing protocols.

The time value, estimated by the EPA-approved and peer-reviewed PBPK model or its equivalent, is that required for the human arterial blood level for a given halocarbon to equal the arterial blood level of a dog exposed to the LOAEL for 5 minutes.

For example, if a system is designed to achieve a maximum concentration of 12.0 percent HFC-125, then means should be provided such that personnel are exposed for no longer than 1.67 minutes. Examples of suitable exposure limiting



mechanisms include self-contained breathing apparatuses and planned and rehearsed evacuation routes.

The requirement for pre-discharge alarms and time delays is intended to prevent human exposure to agents during fire fighting. However, in the unlikely circumstance that an accidental discharge occurs, restrictions on the use of certain halocarbon agents covered in this standard are based on the availability of PBPK modeling information. For those halocarbon agents in which modeling information is available, means should be provided to limit the exposure to those concentrations and times specified in the tables in 1.5.1.2.1. The concentrations and times given in the tables are those that have been predicted to limit the human arterial blood concentration to below the critical arterial blood concentration associated with cardiac sensitization. For halocarbon agents where the needed data are unavailable, the agents are restricted based on whether the protected space is normally occupied or unoccupied, and how quickly egress from the area can be effected. Normally occupied areas are those intended for human occupancy. Normally unoccupied areas are those in which personnel can be present from time to time. Therefore, a comparison of the cardiac sensitization values to the intended design concentration would determine the suitability of a halocarbon for use in normally occupied or unoccupied areas.

Clearly, longer exposure of the agent to high temperatures would produce greater concentrations of these gases. The type and sensitivity of detection, coupled with the rate of discharge, should be selected to minimize the exposure time of the agent to the elevated temperature if the concentration of the breakdown products must be minimized. In most cases the area would be untenable for human occupancy due to the heat and breakdown products of the fire itself.

These decomposition products have a sharp, acrid odor, even in minute concentrations of only a few parts per million. This characteristic provides a built-in warning system for the agent, but at the same time creates a noxious, irritating atmosphere for those who must enter the hazard following a fire.

Background and Toxicology of Hydrogen Fluoride.

Hydrogen fluoride (HF) vapor can be produced in fires as a breakdown product of fluorocarbon fire extinguishing agents and in the combustion of fluoropolymers.

The significant toxicological effects of HF exposure occur at the site of contact. By the inhalation route, significant deposition is predicted to occur in the most anterior (front part) region of the nose and extending back to the lower respiratory tract (airways and lungs) if sufficient exposure concentrations are achieved. The damage induced at the site of contact with HF is characterized by extensive tissue damage and cell death (necrosis) with inflammation. One day after a single, 1 hour exposure of rats to HF concentrations of 950 ppm to 2600 ppm, tissue injury was limited exclusively to the anterior section of the nose (DuPont, 1990). No effects were seen in the trachea or lungs.

At high concentrations of HF (about 200 ppm), human breathing patterns would be expected to change primarily from nose breathing to primarily mouth breathing. This change in breathing pattern determines the deposition pattern of HF into the respiratory tract, either upper respiratory tract (nose breathing) or lower respiratory tract (mouth breathing). In studies conducted by Dalby (Dalby, 1996), rats were exposed by nose-only or mouth-only breathing. In the mouth-breathing only model, rats were exposed to various concentrations of HF through a tube placed in the trachea, thereby bypassing the upper respiratory tract. This exposure method is considered to be a conservative approach for estimating a “worst case” exposure in which a per-

son would not breath through the nose but inhale through the mouth, thereby maximizing the deposition of HF into the lower respiratory tract.

In the nose-breathing model, 2 minute or 10 minute exposures of rats to about 6400 or 1700 ppm, respectively, produced similar effects; that is, no mortality resulted but significant cell damage in the nose was observed. In contrast, marked differences in toxicity were evident in the mouth-breathing model. Indeed, mortality was evident following a 10 minute exposure to a concentration of about 1800 ppm and a 2 minute exposure to about 8600 ppm. Significant inflammation of the lower respiratory tract was also evident. Similarly, a 2 minute exposure to about 4900 ppm produced mortality and significant nasal damage. However, at lower concentrations (950 ppm) following a 10 minute exposure or 1600 ppm following a 2 minute exposure, no mortality and only minimal irritation were observed.

Numerous other toxicology studies have been conducted in experimental animals for longer durations, such as 15, 30, or 60 minutes. In nearly all of these studies, the effects of HF were generally similar across all species; that is, severe irritation of the respiratory tract was observed as the concentration of HF was increased.

In humans, an irritation threshold appears to be at about 3 ppm, where irritation of the upper airways and eyes occurs. In prolonged exposure at about 5 ppm, redness of the skin has also resulted. In controlled human exposure studies, humans are reported to have tolerated mild nasal irritation (subjective response) at 32 ppm for several minutes (Machle et al., 1934). Exposure of humans to about 3 ppm for an hour produced slight eye and upper respiratory tract irritation. Even with an increase in exposure concentration (up to 122 ppm) and a decrease in exposure duration to about 1 minute, skin, eye, and respiratory tract irritation occurs (Machle and Kitzmiller, 1935).

Meldrum (Meldrum, 1993) proposed the concept of the dangerous toxic load (DTL) as a means of predicting the effects of, for example, HF in humans. Meldrum developed the argument that the toxic effects of certain chemicals tend to follow Haber’s law:

$$C \times t = k$$

where:

C = concentration

t = time

k = constant

The available data on the human response to inhalation of HF were considered insufficient to provide a basis for establishing a DTL. Therefore, it was necessary to use the available animal lethality data to establish a model for the response in humans. The DTL is based on an estimate of 1 percent lethality in an exposed population of animals. Based on the analysis of animal lethality data, the author determined that the DTL for HF is 12,000 ppm/min. Although this approach appears reasonable and consistent with mortality data in experimental animals, the predictive nature of this relationship for nonlethal effects in humans has not been demonstrated.

Potential Human Health Effects and Risk Analysis in Fire Scenarios.

It is important for a risk analysis to distinguish between normally healthy individuals, such as fire fighters, and those with compromised health. Exposure to higher concentrations of HF would be expected to be tolerated more in healthy individuals, whereas equal concentrations can have escape-impairing effects in those with compromised health. The following discussion

assumes that the effects described at the various concentrations and durations are for the healthy individual.

Inflammation (irritation) of tissues represents a continuum from “no irritation” to “severe, deep penetrating” irritation. Use of terms *slight*, *mild*, *moderate*, and *severe* in conjunction with irritation represents an attempt to quantify this effect. However, given the large variability and sensitivity of the human population, differences in the degree of irritation from exposure to HF are expected to occur. For example, some individuals can experience mild irritation to a concentration that results in moderate irritation in another individual.

At concentrations of <50 ppm for up to 10 minutes, irritation of upper respiratory tract and the eyes would be expected to occur. At these low concentrations, escape-impairing effects would not be expected in the healthy individual. As HF concentrations increase to 50 ppm to 100 ppm, an increase in irritation is expected. For short duration (10 to 30 minutes) irritation of the skin, eyes, and respiratory tract would occur. At 100 ppm for 30 to 60 minutes, escape-impairing effects would begin to occur, and continued exposure at 200 ppm and greater for an hour could be lethal in the absence of medical intervention. As the concentration of HF increases, the severity of irritation increases, and the potential for delayed systemic effects also increases. At about 100 to 200 ppm of HF, humans would also be expected to shift their breathing pattern to mouth breathing. Therefore, deeper lung irritation is expected. At greater concentrations (>200 ppm), respiratory discomfort, pulmonary (deep lung) irritation, and systemic effects are possible. Continued exposure at these higher concentrations can be lethal in the absence of medical treatment.

Generation of HF from fluorocarbon fire extinguishing agents represents a potential hazard. In the foregoing discussion, the duration of exposure was indicated for 10 to 60 minutes. In fire conditions in which HF would be generated, the actual exposure duration would be expected to be less than 10 minutes and in most cases less than 5 minutes. As Dalby (Dalby, 1996) showed, exposing mouth breathing rats to HF concentrations of about 600 ppm for 2 minutes was without effect. Similarly, exposing mouth breathing rats to a HF concentration of about 300 ppm for 10 minutes did not result in any mortality or respiratory effects. Therefore, one could surmise that humans exposed to similar concentrations for less than 10 minutes would be able to survive such concentrations. However, caution needs to be employed in interpreting these data. Although the toxicity data would suggest that humans could survive these large concentrations for less than 10 minutes, those individuals with compromised lung function or those with cardiopulmonary disease can be more susceptible to the effects of HF. Furthermore, even in the healthy individual, irritation of the upper respiratory tract and eyes would be expected, and escape could be impaired.

Table A.1.5.1.2(b) provides potential human health effects of hydrogen fluoride in healthy individuals.

Occupational exposure limits have been established for HF. The limit set by the American Conference of Governmental Industrial Hygienists (ACGIH), the Threshold Limit Value (TLV[®]), represents exposure of normally healthy workers for an 8 hour workday or 40 hour workweek. For HF, the limit established is 3 ppm, which represents a ceiling limit; that is, the airborne concentration that should not be exceeded at any time during the workday. This limit is intended to prevent irritation and possible systemic effects with repeated, long-term exposure. This and similar time-weighted average limits are not considered relevant for fire extinguishing use of fluorocarbons during emergency situations. However, these limits may need to be considered in

clean-up procedures where high levels of HF were generated. For more information, contact the American Conference of Governmental Industrial Hygienists, 1330 Kemper Meadow Drive, Cincinnati, OH 45240, (513) 742-2020.

In contrast to the ACGIH TLV, the American Industrial Hygiene Association (AIHA) Emergency Response Planning Guideline (ERPG) represents limits established for emergency release of chemicals. These limits are established to also account for sensitive populations, such as those with compromised health. The ERPG limits are designed to assist emergency response personnel in planning for catastrophic releases of chemicals. These limits are not developed to be used as “safe” limits for routine operations. However, in the case of

Table A.1.5.1.2(b) Potential Human Health Effects of Hydrogen Fluoride in Healthy Individuals

Exposure Time	Hydrogen Fluoride (ppm)	Reaction
2 minutes	<50	Slight eye and nasal irritation
	50–100	Mild eye and upper respiratory tract irritation
	100–200	Moderate eye and upper respiratory tract irritation; slight skin irritation
	>200	Moderate irritation of all body surfaces; increasing concentration may be escape impairing
5 minutes	<50	Mild eye and nasal irritation
	50–100	Increasing eye and nasal irritation; slight skin irritation
	100–200	Moderate irritation of skin, eyes, and respiratory tract
	>200	Definite irritation of tissue surfaces; will cause escape impairing at increasing concentrations
10 minutes	<50	Definite eye, skin, and upper respiratory tract irritation
	50–100	Moderate irritation of all body surfaces
	100–200	Moderate irritation of all body surfaces; escape-impairing effects likely
	>200	Escape-impairing effects will occur; increasing concentrations can be lethal without medical intervention



fire extinguishing use and generation of HF, these limits are more relevant than time-weighted average limits such as the TLV. The ERPG limits consist of three levels for use in emergency planning and are typically 1 hour values; 10 minute values have also been established for HF. For the 1 hour limits, the ERPG 1 (2 ppm) is based on odor perception and is below the concentration at which mild sensory irritation has been reported (3 ppm). ERPG 2 (20 ppm) is the most important guideline value set and is the concentration at which mitigating steps should be taken, such as evacuation, sheltering, and donning masks. This level should not impede escape or cause irreversible health effects and is based mainly on the human irritation data obtained by Machle et al. (Machle et al., 1934) and Largent (Largent, 1960). ERPG 3 (50 ppm) is based on animal data and is the maximum nonlethal level for nearly all individuals. This level could be lethal to some susceptible people. The 10 minute values established for HF and used in emergency planning in fires where HF vapor is generated are ERPG 3 = 170 ppm, ERPG 2 = 50 ppm, and ERPG 1 = 2 ppm. For more information, contact the American Industrial Hygiene Association, 2700 Prosperity Ave., Suite 250, Fairfax, VA 22031, (703) 849-8888, fax (703) 207-3561.

A.1.5.1.2.1 One objective of pre-discharge alarms and time delays is to prevent human exposure to agents.

A.1.5.1.3 Paragraph 1.5.1.3 makes reference to limiting concentrations of inert gas agents corresponding to certain values of “sea level equivalent” of oxygen. The mean atmospheric pressure of air at sea level is 760 mm Hg. Atmospheric air is 21 volume percent oxygen. The partial pressures of oxygen in ambient air and air diluted agent to the limiting sea level concentrations corresponding to permissible exposure times of 5, 3, and ½ minutes are given in Table A.1.5.1.3(a).

Table A.1.5.1.3(a) Oxygen Partial Pressure at Sea Level* Corresponding to Exposure Limits of 1.5.1.3

Exposure Time (min)	Agent Concentration (vol %)	O ₂ % at Sea Level	Partial Pressure O ₂ (mm Hg)
Air reference	0%	21%	159.6
5	43%	12.0%	91.0
3	52%	10.1%	76.6
½	62%	8.0%	60.6

*Mean atmospheric pressure at sea level is 760 mm Hg.

In 3.3.28, *sea level equivalent of oxygen* is defined in terms of the partial pressure at sea level. The mean atmospheric pressure decreases with increasing altitude as shown in Table 5.5.3.3. The partial pressure of oxygen is 21 percent of the atmospheric pressure. The concentration of added agent, which dilutes air to the sea level limiting partial pressure of oxygen, is given by

$$\text{Vol. \% agent} = \left(\frac{0.21P_{\text{ATM}} - P_{\text{O}_2, \text{LIM}}}{0.21P_{\text{ATM}}} \right) \times 100$$

where:

P_{ATM} = local mean atmospheric pressure

$P_{\text{O}_2, \text{LIM}}$ = limiting partial pressure of oxygen corresponding to a sea level exposure time limit

The effect of altitude on limiting agent concentrations is given in Table A.1.5.1.3(b).

Table A.1.5.1.3(c) provides information on physiological effects of inert gas agents covered by this standard. The health concern for inert gas clean agents is asphyxiation due to the lowered oxygen levels. With inert gas agents, an oxygen concentration of no less than 10 percent (sea level equivalent) is required for normally occupied areas. This corresponds to an agent concentration of no more than 52 percent.

IG-541 uses carbon dioxide to promote breathing characteristics intended to sustain life in the oxygen-deficient environment for protection of personnel. Care should be used not to design inert gas-type systems for normally occupied areas using design concentrations higher than that specified in the system manufacturer’s listed design manual for the hazard being protected.

Inert gas agents do not decompose measurably in extinguishing a fire. As such, toxic or corrosive decomposition products are not found. However, heat and breakdown products of the fire itself can still be substantial and could make the area untenable for human occupancy.

A.1.5.1.4.1 The steps and safeguards necessary to prevent injury or death to personnel in areas whose atmospheres will be made hazardous by the discharge or thermal decomposition of clean agents can include the following:

- (1) Provision of adequate aiseways and routes of exit, and procedures to keep them clear at all times.
- (2) Provision of emergency lighting and directional signs as necessary to ensure quick, safe evacuation.
- (3) Provision of alarms within such areas that will operate immediately upon detection of the fire.
- (4) Provision of only outward-swinging, self-closing doors at exits from hazardous areas and, where such doors are latched, provision of panic hardware.
- (5) Provision of continuous alarms at entrances to such areas until the atmosphere has been restored to normal.
- (6) Provision of warning and instruction signs at entrances to and inside such areas. These signs should inform persons in or entering the protected area that a clean agent system is installed and should contain additional instructions pertinent to the conditions of the hazard.
- (7) Provision for the prompt discovery and rescue of persons rendered unconscious in such areas. This should be accomplished by having such areas searched immediately by trained personnel equipped with proper breathing equipment. Self-contained breathing equipment and personnel trained in its use and in rescue practices, including artificial respiration, should be readily available.
- (8) Provision of instruction and drills for all personnel within or in the vicinity of such areas, including maintenance or construction people who could be brought into the area, to ensure their correct action when a clean agent system operates.
- (9) Provision of means for prompt ventilation of such areas. Forced ventilation will often be necessary. Care should be taken to readily dissipate hazardous atmospheres and not merely move them to another location.
- (10) Prohibition against smoking by persons until the atmosphere has been determined to be free of the clean agent.
- (11) Provision of such other steps and safeguards that a careful study of each particular situation indicates is necessary to prevent injury or death.

A.1.5.1.4.2 A certain amount of leakage from a protected space to adjacent areas is anticipated during and following agent discharge. Consideration should be given to agent concentration (when above NOAEL), decomposition products,

Table A.1.5.1.3(b) Relationship of Altitude to Atmospheric Pressure, Oxygen Partial Pressure in Air, and Limiting Agent Concentration

Altitude Above Sea Level (ft)	P _{ATM} (mm Hg)	O ₂ Partial Pressure in Air (mm Hg)	Limiting Agent Concentration		
			5 min Exposure P(O ₂) = 91 (mm Hg)	3 min Exposure P(O ₂) = 76.6 (mm Hg)	30 sec Exposure P(O ₂) = 60.6 (mm Hg)
-3,000	840	176.4	48.4%	56.6%	65.6%
-2,000	812	170.5	46.6%	55.1%	64.5%
-1,000	787	165.3	44.9%	53.7%	63.3%
0	760	159.6	43.0%	52.0%	62.0%
1,000	733	153.9	40.9%	50.2%	60.6%
2,000	705	148.1	38.5%	48.3%	59.1%
3,000	679	142.6	36.2%	46.3%	57.5%
4,000	650	136.5	33.3%	43.9%	55.6%
5,000	622	130.6	30.3%	41.4%	53.6%
6,000	596	125.2	27.3%	38.8%	51.6%
7,000	570	119.7	24.0%	36.0%	49.4%
8,000	550	115.5	21.2%	33.7%	47.5%
9,000	528	110.9	17.9%	30.9%	45.3%
10,000	505	106.1	14.2%	27.8%	42.9%

Table A.1.5.1.3(c) Physiological Effects of Inert Gas Agents

Agent	No Effect Level* (%)	Low Effect Level* (%)
IG-01	43	52
IG-100	43	52
IG-55	43	52
IG-541	43	52

*Based on physiological effects in humans in hypoxic atmospheres. These values are the functional equivalents of NOAEL and LOAEL values and correspond to 12 percent minimum oxygen for the no effect level and 10 percent minimum oxygen for the low effect level.

products of combustion, and relative size of adjacent spaces. Additional consideration should be given to exhaust paths when opening or venting the enclosure after a discharge.

A.1.5.1.4.4 Inert gases used to operate pre-discharge alarms include inert gas clean agents, nitrogen, and carbon dioxide.

A.1.6 Many factors impact the environmental acceptability of a fire suppression agent. Uncontrolled fires pose significant impact by themselves. All extinguishing agents should be used in ways that eliminate or minimize the potential environmental impact. General guidelines to be followed to minimize this impact include the following:

- (1) Do not perform unnecessary discharge testing.
- (2) Consider the ozone depletion and global warming impact of the agent under consideration and weigh these impacts against the fire safety concerns.
- (3) Recycle all agents where possible.
- (4) Consult the most recent environmental regulations on each agent.

The unnecessary emission of clean extinguishing agents with either the potential of ozone depletion or the potential of global warming, or the potential of both, should be avoided. All phases of design, installation, testing, and maintenance of

systems using these agents should be performed with the goal of no emission into the environment.

A.1.8.1 It is generally believed that, because of the highly stable nature of the compounds that are derived from the families including halogenated hydrocarbons and inert gases, incompatibility will not be a problem. These materials tend to behave in a similar fashion, and, as far as is known, the reactions that could occur as the result of mixing of these materials within the container is not thought to be a real consideration with regard to their application to a fire protection hazard.

It is clearly not the intent of this section to deal with compatibility of the agents with components of the extinguishing hardware, nor to deal with the subject of storability or storage life of individual agents or mixtures of those agents. Each of these concerns is addressed elsewhere in this standard.

A.3.2.1 Approved. The National Fire Protection Association does not approve, inspect, or certify any installations, procedures, equipment, or materials; nor does it approve or evaluate testing laboratories. In determining the acceptability of installations, procedures, equipment, or materials, the authority having jurisdiction may base acceptance on compliance with NFPA or other appropriate standards. In the absence of such standards, said authority may require evidence of proper installation, procedure, or use. The authority having jurisdiction may also refer to the listings or labeling practices of an organization that is concerned with product evaluations and is thus in a position to determine compliance with appropriate standards for the current production of listed items.

A.3.2.2 Authority Having Jurisdiction (AHJ). The phrase "authority having jurisdiction," or its acronym AHJ, is used in NFPA documents in a broad manner, since jurisdictions and approval agencies vary, as do their responsibilities. Where public safety is primary, the authority having jurisdiction may be a federal, state, local, or other regional department or individual such as a fire chief; fire marshal; chief of a fire prevention bureau, labor department, or health department; building official; electrical inspector; or others having statutory



authority. For insurance purposes, an insurance inspection department, rating bureau, or other insurance company representative may be the authority having jurisdiction. In many circumstances, the property owner or his or her designated agent assumes the role of the authority having jurisdiction; at government installations, the commanding officer or departmental official may be the authority having jurisdiction.

A.3.3.23 Listed. The means for identifying listed equipment may vary for each organization concerned with product evaluation; some organizations do not recognize equipment as listed unless it is also labeled. The authority having jurisdiction should utilize the system employed by the listing organization to identify a listed product.

A.3.3.13 Halocarbon Agent. Examples are hydrofluorocarbons (HFCs), hydrochlorofluorocarbons (HCFCs), perfluorocarbons (PFCs or FCs), fluoriodocarbons (FICs), and fluoroketones (FKs).

A.3.3.22 Normally Occupied Enclosure or Space. Spaces occasionally visited by personnel, such as transformer bays, switch houses, pump rooms, vaults, engine test stands, cable trays, tunnels, microwave relay stations, flammable liquid storage areas, and enclosed energy systems are examples of areas considered not normally occupied.

A.4.1.1.2 An extra-full complement of charged cylinders (connected reserve) manifolded and piped to feed into the automatic system should be considered on all installations. The reserve supply is normally actuated by manual operation of the main/reserve switch on either electrically operated or pneumatically operated systems. A connected reserve is desirable for the following reasons:

- (1) Provides protection should a reflash occur
- (2) Provides reliability should the main bank malfunction
- (3) Provides protection during impaired protection when main tanks are being replaced
- (4) Provides protection of other hazards if selector valves are involved and multiple hazards are protected by the same set of cylinders

If a full complement of charged cylinders cannot be obtained or if the empty cylinder cannot be recharged, delivered, and reinstalled within 24 hours, a third complement of fully charged, nonconnected spare cylinders should be considered and made available on the premises for emergency use. The need for spare cylinders could depend on whether or not the hazard is under the protection of automatic sprinklers.

A.4.1.2 The normal and accepted procedures for making these quality measurements will be provided by the chemical manufacturers in a future submittal. As each clean agent varies in its quality characteristics, a more comprehensive table than the one currently in the standard will be developed. It will be submitted through the public proposal process. Recovered or recycled agents are currently not available, and thus quality standards do not exist at this time. As data become available, these criteria will be developed.

A.4.1.3.2 Storage containers should not be exposed to a fire in a manner likely to impair system performance.

A.4.1.4.1 Containers used for agent storage should be fit for the purpose. Materials of construction of the container, closures, gaskets, and other components should be compatible with the agent and designed for the anticipated pressures. Each container is equipped with a pressure relief device to protect against excessive pressure conditions.

The variations in vapor pressure with temperature for the various clean agents are shown in Figure A.4.1.4.1 (a) through Figure A.4.1.4.1 (m).

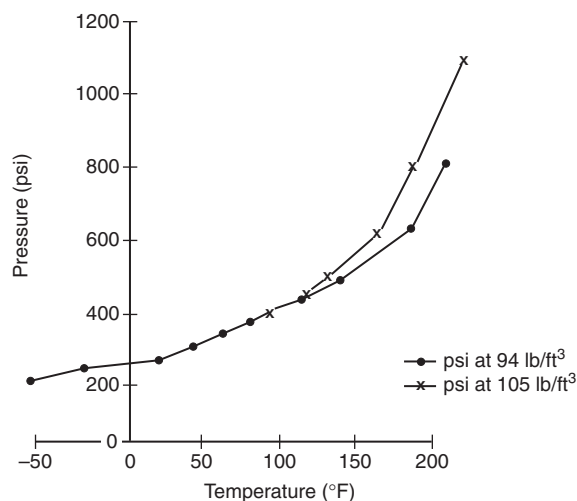

Note: CF3I pressure versus temperature at 94 and 105 lb/ft³.

(1) U.S. (°F)

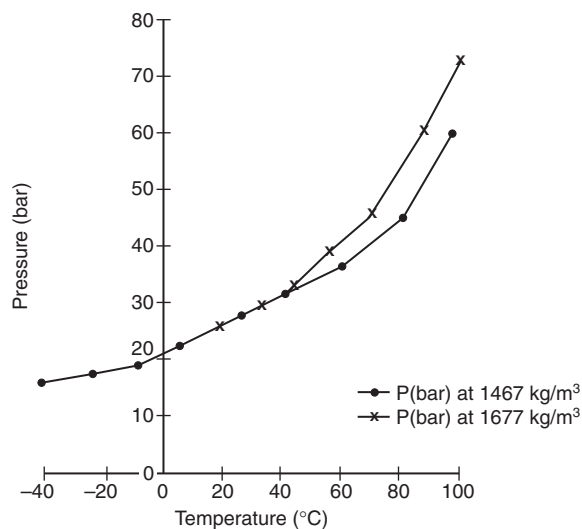

Note: CF3I pressure versus temperature at 1467 and 1677 kg/m³.

(2) SI (°C)

FIGURE A.4.1.4.1 (a) Isometric Diagram of FIC-131I.

For halocarbon clean agents, the pressure in the container is significantly affected by fill density and temperature. At elevated temperatures, the rate of increase in pressure is very sensitive to fill density. If the maximum fill density is exceeded, the pressure will increase rapidly with temperature increase so as to present a hazard to personnel and property. Therefore, it is very important that the maximum fill density limit specified for each liquefied clean agent not be exceeded. Adherence to

the limits for fill density and pressurization levels specified in Table A.4.1.4.1 should prevent excessively high pressures from occurring if the agent container is exposed to elevated temperatures. Adherence to the limits will also minimize the possibility of an inadvertent discharge of agent through the pressure relief device. The manufacturer should be consulted for superpressurization levels other than those shown in Table A.4.1.4.1.

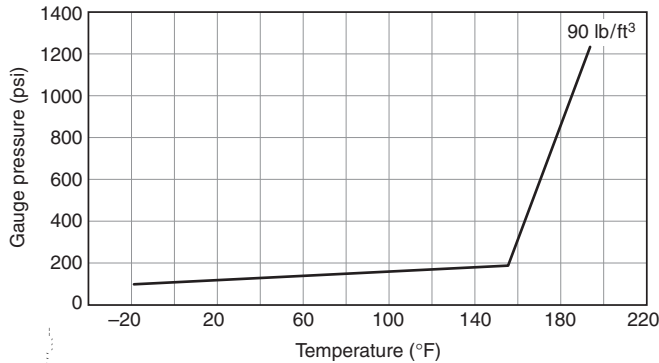

(1) For 150 psi containers

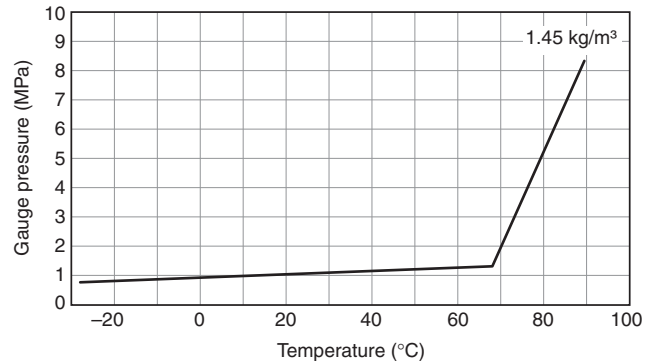

(2) For 1.0 MPa containers

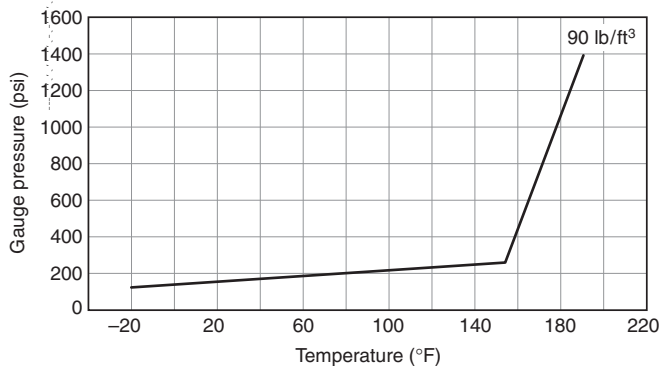

(3) For 195 psi containers

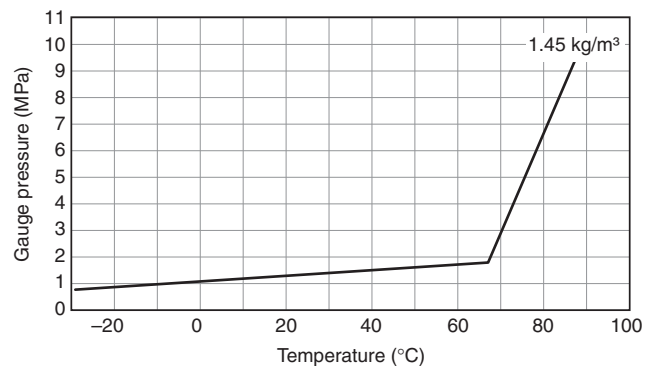

(4) For 1.3 MPa containers

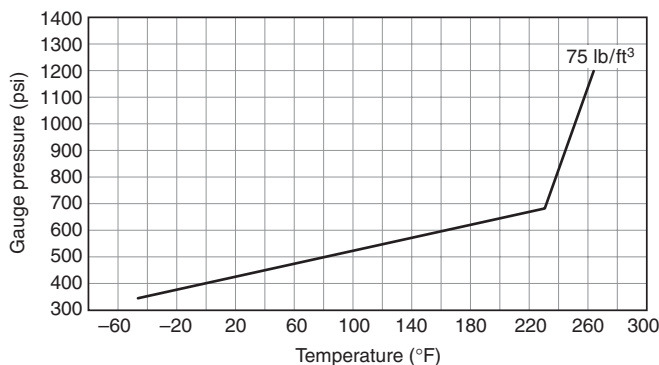

(5) For 500 psi containers

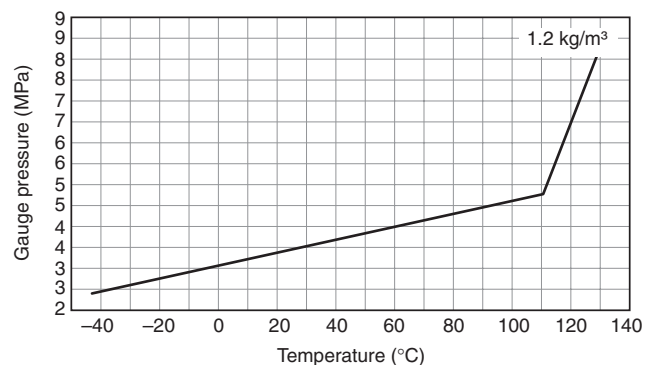

(6) For 3.4 MPa containers

FIGURE A.4.1.4.1(b) Isometric Diagram of FK-5-1-12.

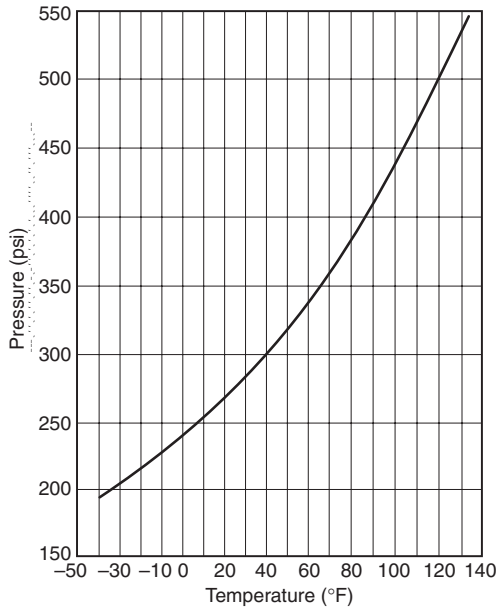

(1) U.S. (°F)

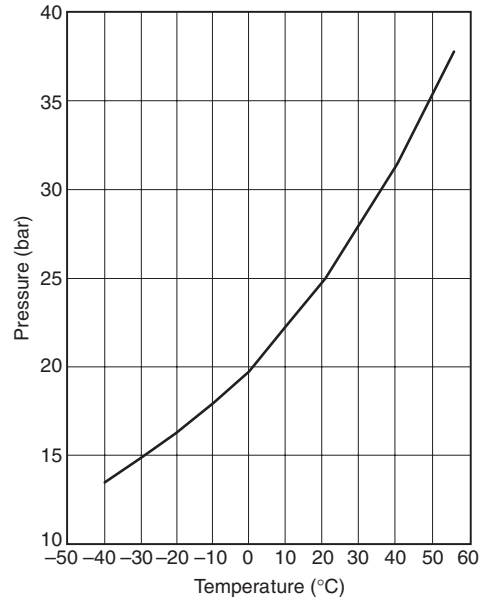

(2) SI (°C)

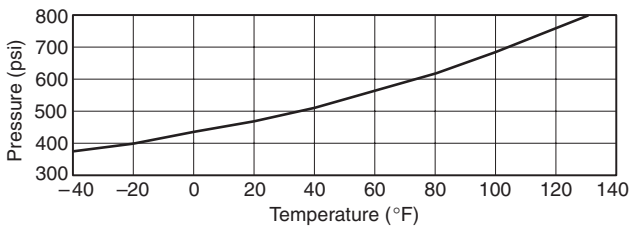

(3) Pressurized with nitrogen to 600 psi at 70°F for fill densities of 31.2 to 56.2 lb/ft³

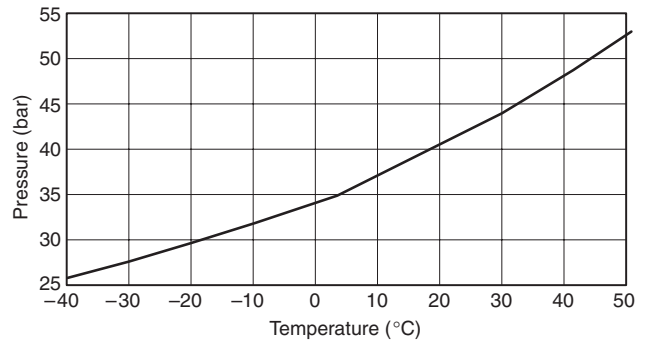

(4) Pressurized with nitrogen to 40 bar at 20°C for fill densities of 0.5 to 0.9 kg/m³

FIGURE A.4.1.4.1(c) Isometric Diagram of HCFC Blend A.

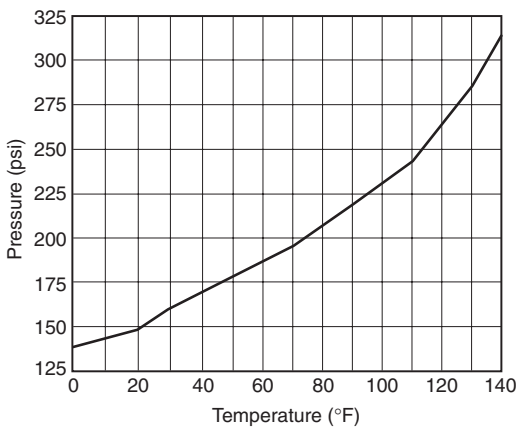

(1) Pressurized to 195 psi at 70°F and a loading density of 71.17 lb/ft³

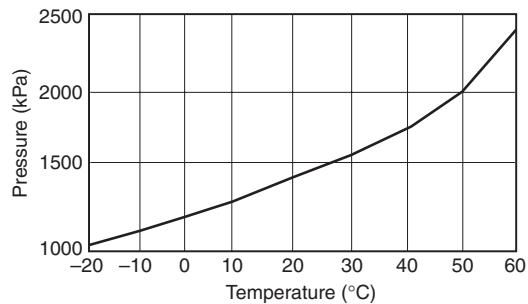

(2) Pressurized to 1340 kPa at 21°C and a loading density of 1140 kg/m³

FIGURE A.4.1.4.1(d) Isometric Diagram of HCFC-124 Pressurized with Nitrogen.

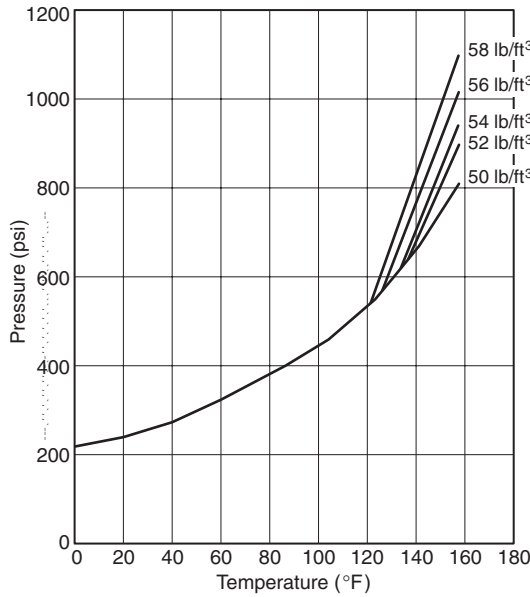

(1) Pressurized to 360 psi at 72°F

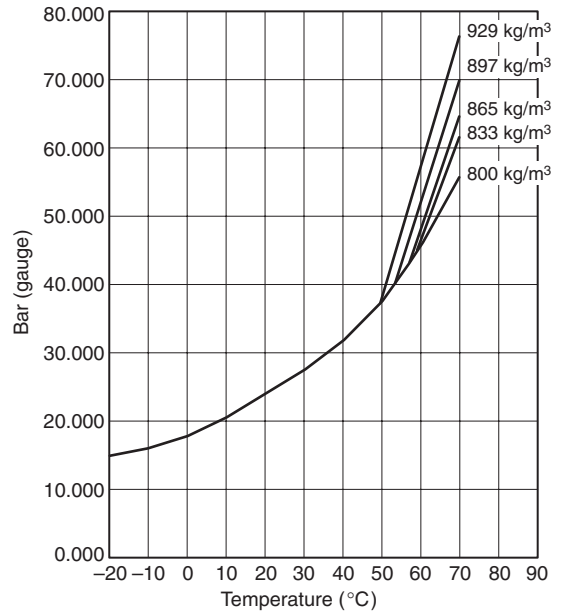

(2) Pressurized to 24.82 bar (gauge) at 22°C

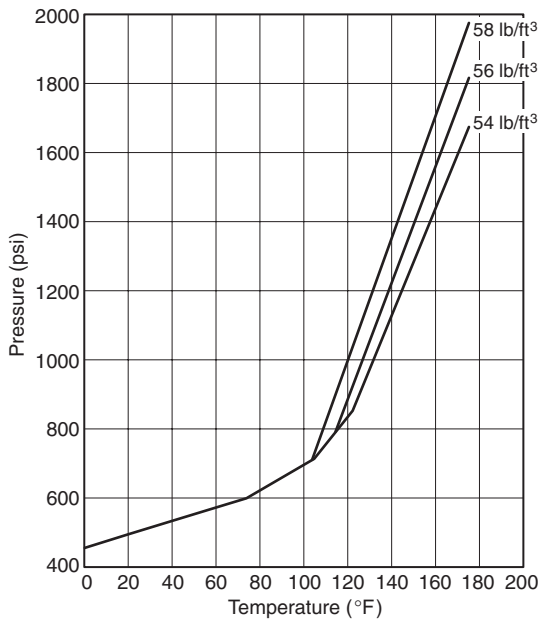

(3) Pressurized to 600 psi at 72°F

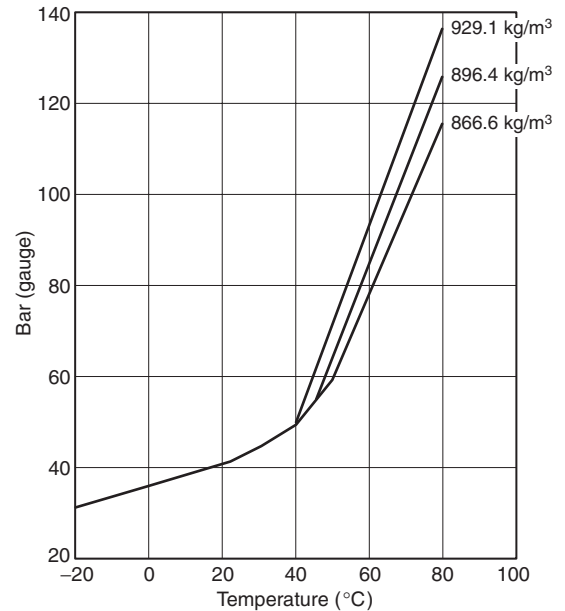

(4) Pressurized to 41.4 bar (gauge) at 22°C

FIGURE A.4.1.4.1(e) Isometric Diagram of HFC-125 Pressurized with Nitrogen.

With the exception of inert gas-type systems, all of the other clean agents are classified as liquefied compressed gases at 70°F (21°C). For these agents, the pressure in the container is significantly affected by fill density and temperature. At elevated temperatures, the rate of increase in pressure is very sensitive to fill density. If the maximum fill density is exceeded, the pressure will increase rapidly with temperature increase so as to present a hazard to personnel and property. Therefore, it is very important that the maximum fill density limit specified

for each liquefied clean agent not be exceeded. Adherence to the limits for fill density and pressurization levels specified in Table A.4.1.4.1 should prevent excessively high pressures from occurring if the agent container is exposed to elevated temperatures. Adherence to the limits will also minimize the possibility of an inadvertent discharge of agent through the pressure relief device. The manufacturer should be consulted for superpressurization levels other than those shown in Table A.4.1.4.1.

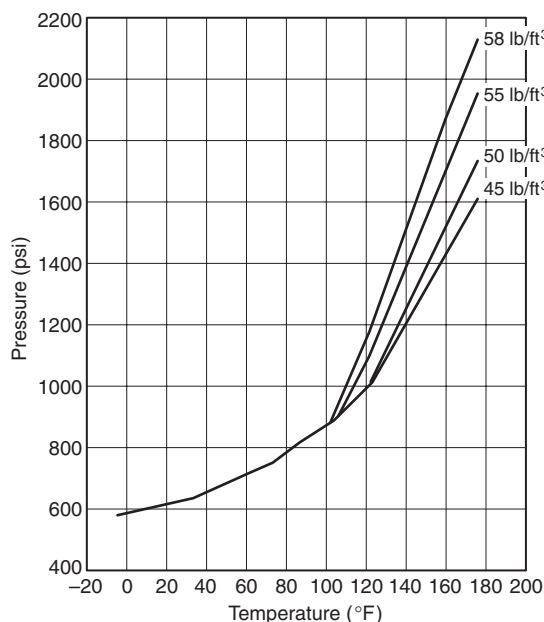

(5) Pressurized to 750 psi at 72°F

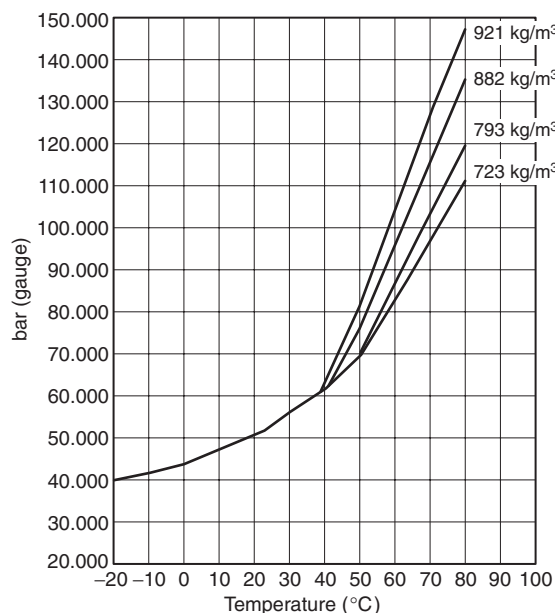

(6) Pressurized to 51.7 bar (gauge) at 22°C

FIGURE A.4.1.4.1(e) *Continued*

A.4.1.4.2 Although it is not a requirement of 4.1.4.2, all new and existing halocarbon agent storage containers should be affixed with a label advising the user that the product in question can be returned for recovery and recycling to a qualified recycler when the halocarbon agent is no longer needed. The qualified recycler can be a halocarbon agent manufacturer, a fire equipment manufacturer, a fire equipment distributor or installer, or an independent commercial venture. It is not the intent to set down specific requirements but to indicate the

factors that need to be taken into consideration with regard to recycling and reclamation of the halocarbon agent products, once facilities are available. As more information becomes available, more definitive requirements can be set forth in this section regarding quality, efficiency, recovery, and qualifications and certifications of facilities recycling halocarbon agents. Currently, no such facilities exist that would apply to the halocarbon agents covered by this document.

Inert gas agents need not be collected or recycled.

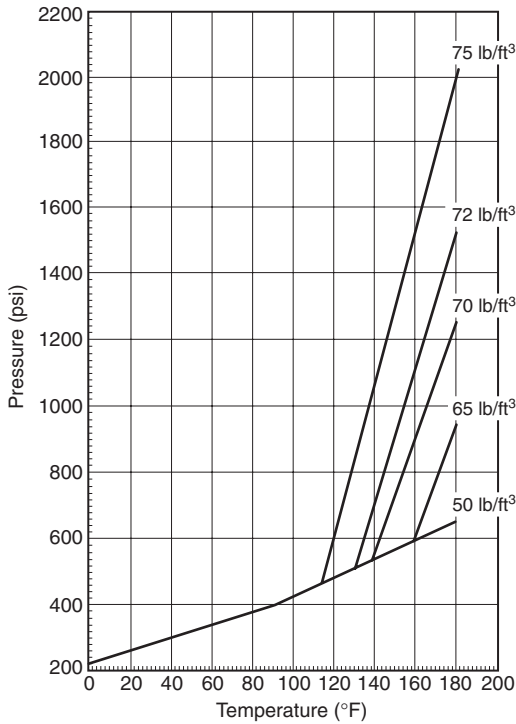

(1) Pressurized to 360 psi at 70°F

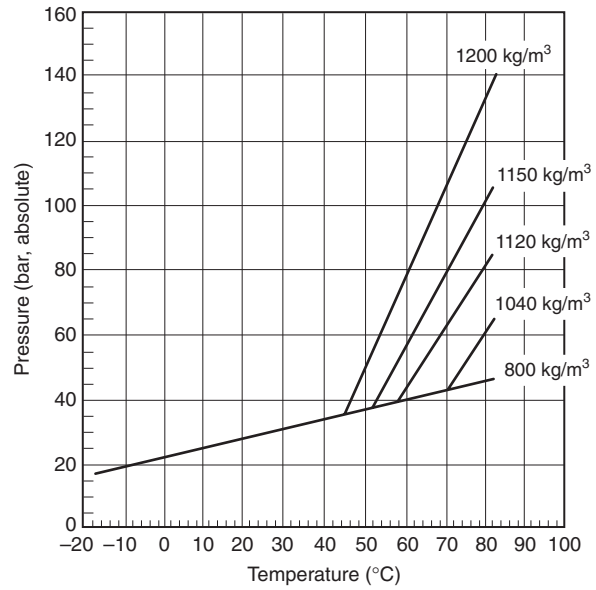

(2) Pressurized to 2.5 MPa at 21°C

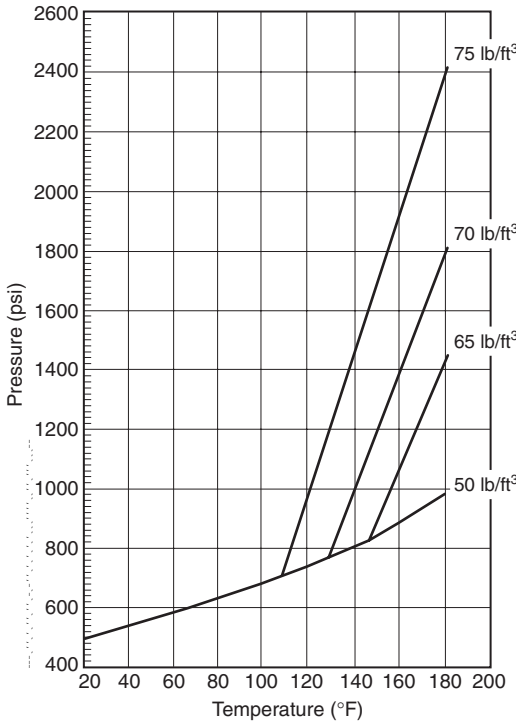

(3) Pressurized to 600 psi at 70°F

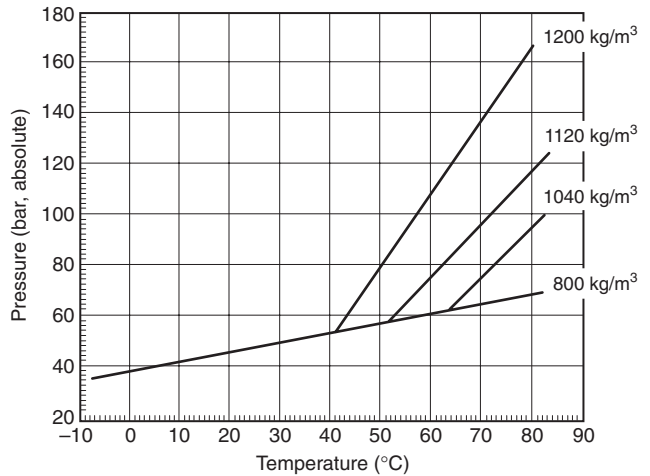

(4) Pressurized to 4.1 MPa at 21°C

FIGURE A.4.1.4.1(f) Isometric Diagram of HFC-227ea Pressurized with Nitrogen.

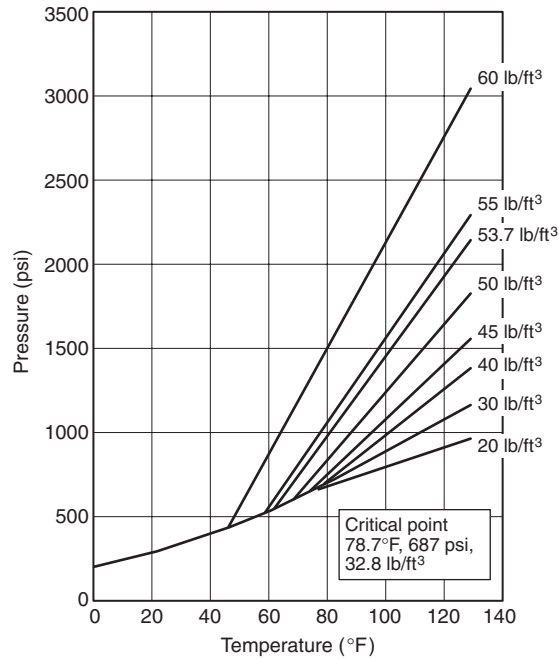

(1) U.S. (°F)

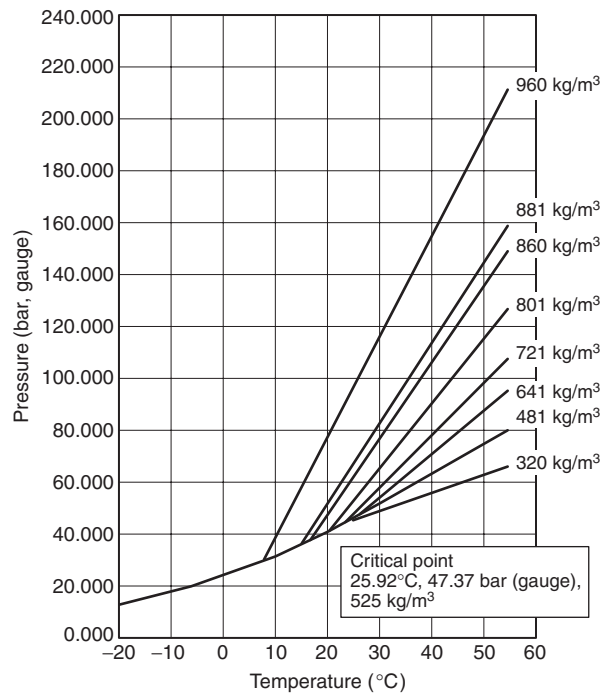

(2) SI (°C)

FIGURE A.4.1.4.1(g) Isometric Diagram of HFC-23.

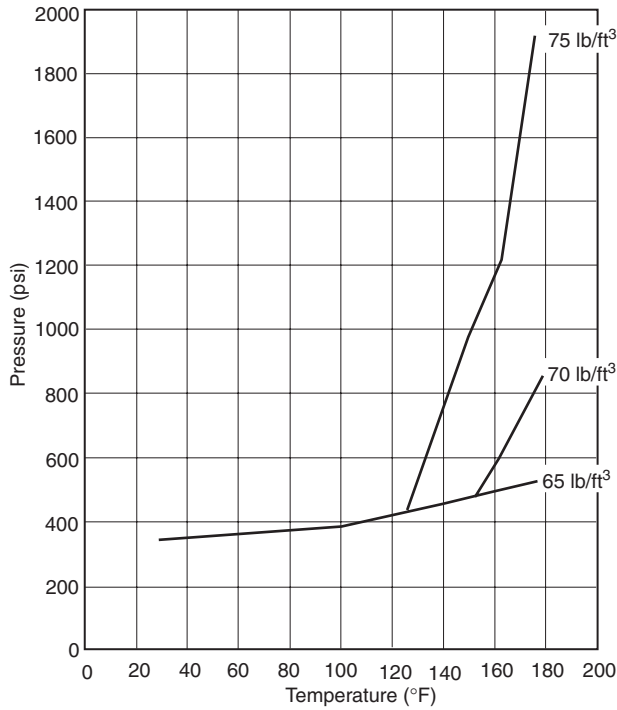

(1) Pressurized to 360 psi at 72°F

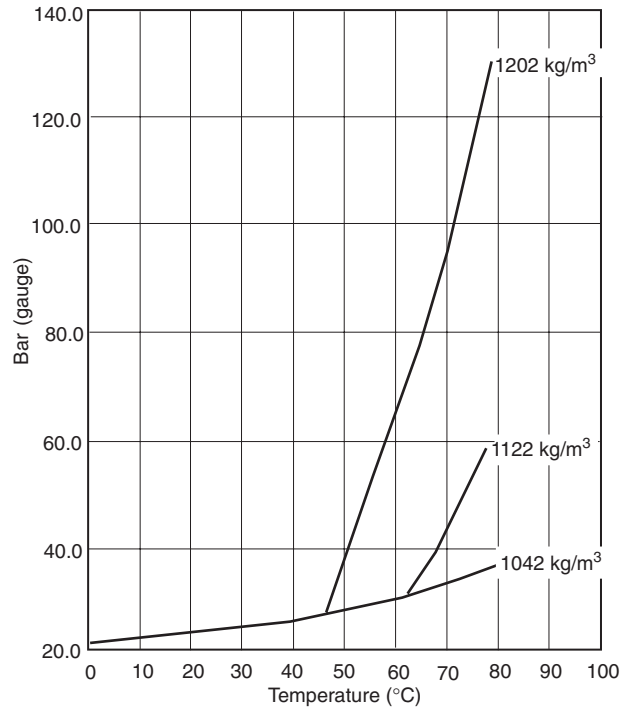

(2) Pressurized to 24.82 bar (gauge) at 22°C

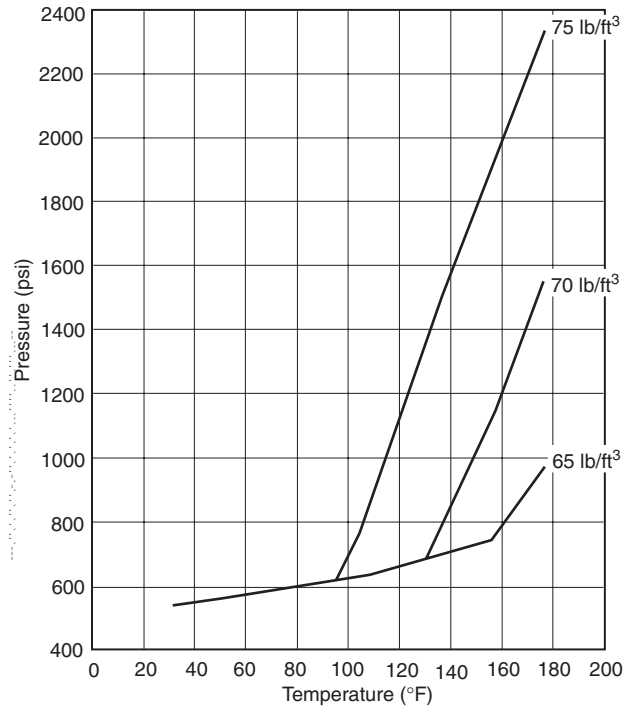

(3) Pressurized to 600 psi at 72°F

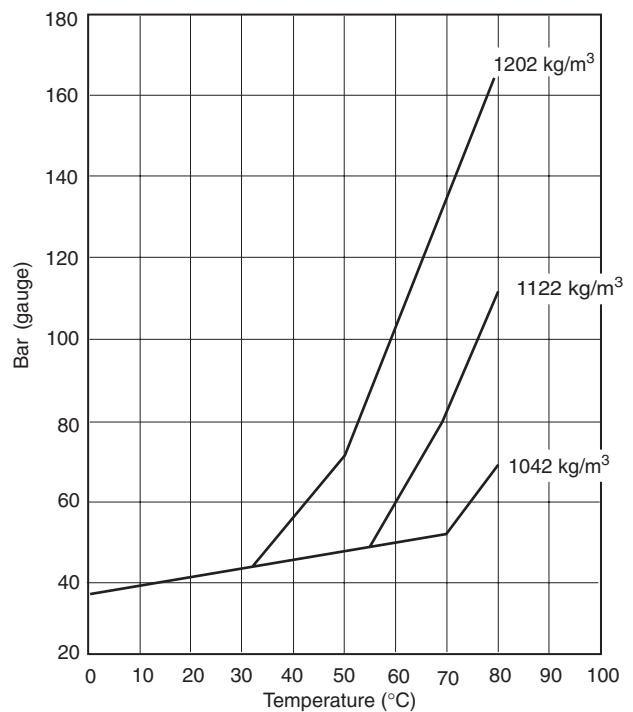

(4) Pressurized to 41.4 bar (gauge) at 22°C

FIGURE A.4.1.4.1 (h) Isometric Diagram of HFC-236fa Pressurized with Nitrogen.

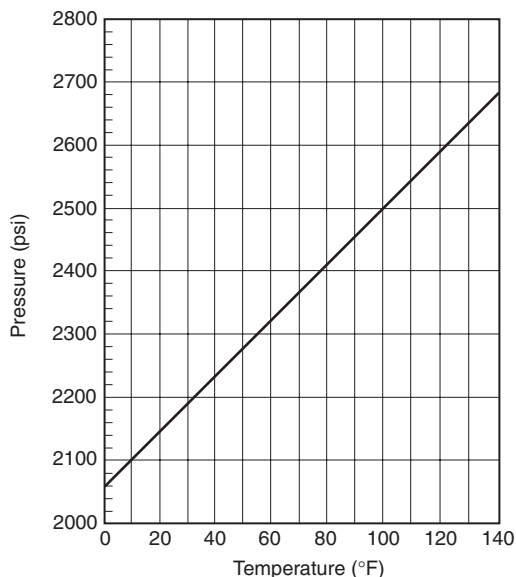

(1) Pressurized to 2370 psi at 70°F

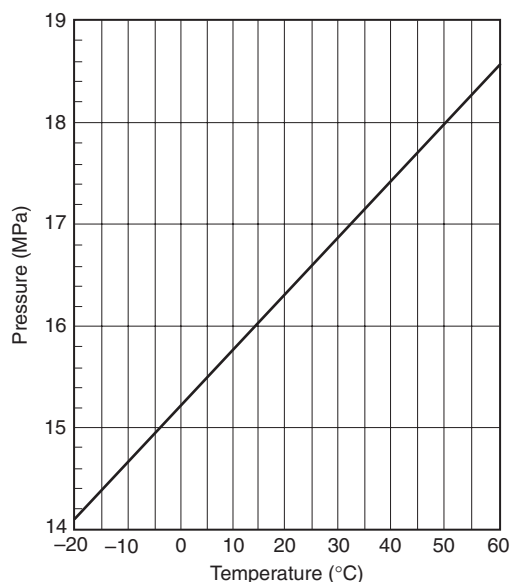

(2) Pressurized to 160 bar at 15°C

FIGURE A.4.1.4.1(i) Isometric Diagram of IG-01.

A.4.1.4.5(2) Inert gas agents are single-phase gases in storage and at all times during discharge.

A.4.2.1 Piping should be installed in accordance with good commercial practice. Care should be taken to avoid possible restrictions due to foreign matter, faulty fabrication, or improper installation.

The piping system should be securely supported with due allowance for agent thrust forces and thermal expansion and

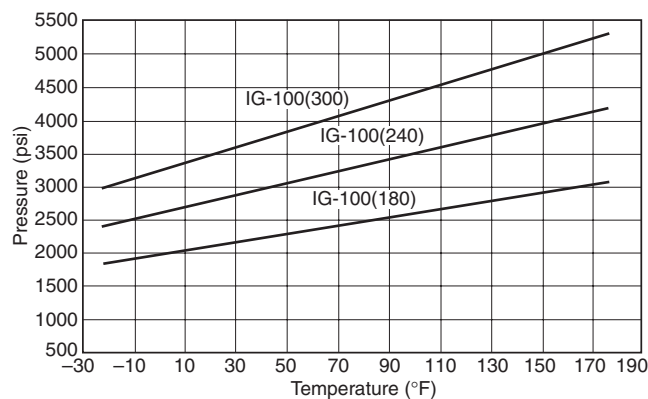

(1) U.S. (°F)

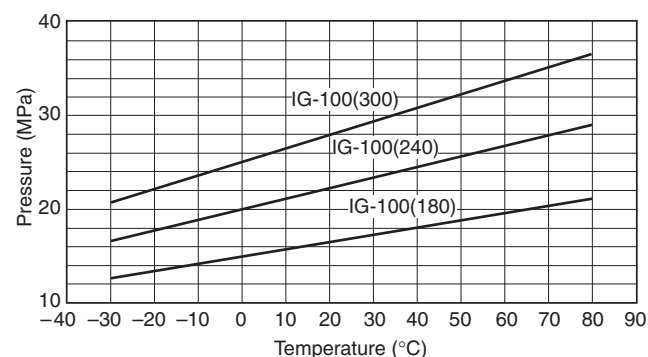

(2) SI (°C)

FIGURE A.4.1.4.1(j) Isometric Diagram of IG-100.

contraction and should not be subjected to mechanical, chemical, vibration, or other damage. ASME B31.1 should be consulted for guidance on this matter. Where explosions are likely, the piping should be attached to supports that are least likely to be displaced.

Although clean agent piping systems are not subjected to continuous pressurization, provisions should be made to ensure that the type of piping installed can withstand the maximum stress at maximum storage temperatures. Maximum allowable stress levels for this condition should be established at values of 67 percent of the minimum yield strength or 25 percent of the minimum tensile strength, whichever is less. All joint factors should be applied after this value is determined.

A.4.2.1.1 Paragraph 4.2.1.1 requires that “the thickness of the piping shall be calculated in accordance with the ...ASME B31.1.” To comply with this requirement, the guidelines found in the *FSSA Pipe Design Handbook* should be followed. The *FSSA Pipe Design Handbook* provides guidance on how to apply ASME B31.1 in a uniform and consistent manner in the selection of acceptable types of pipe and tubing used in special hazard fire suppression systems.

A.4.2.1.6 Design of closed sections of pipe should follow the guidelines in Section 5 of the *FSSA Pipe Design Handbook*.

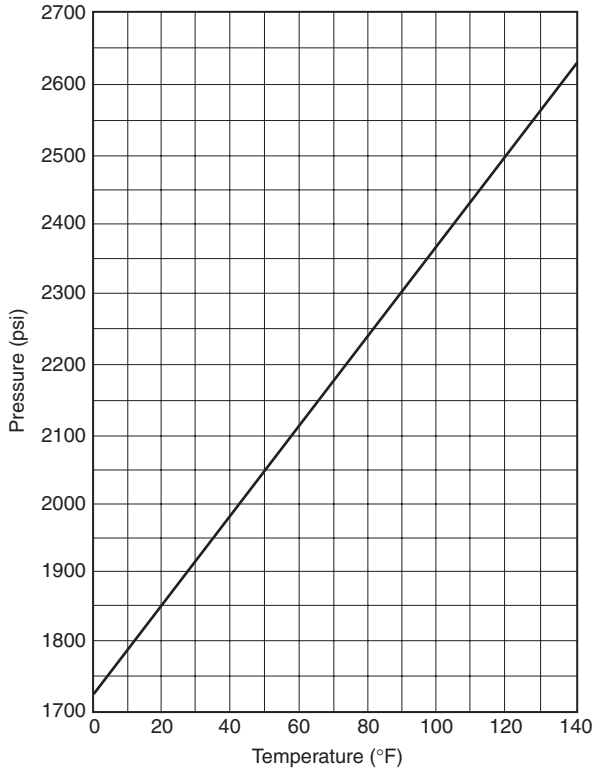

(1) Pressurized to 2175 psi at 70°F

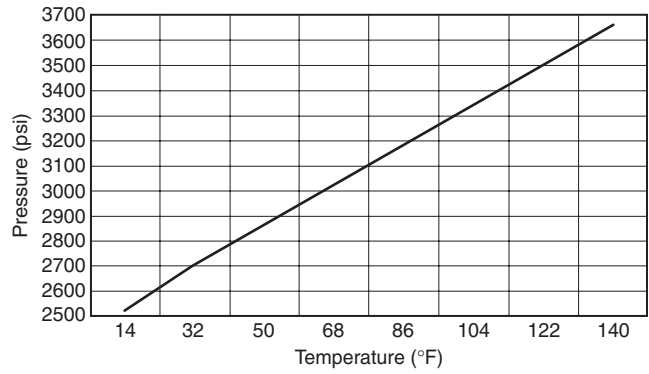

(2) Pressurized to 2900 psi at 59°F

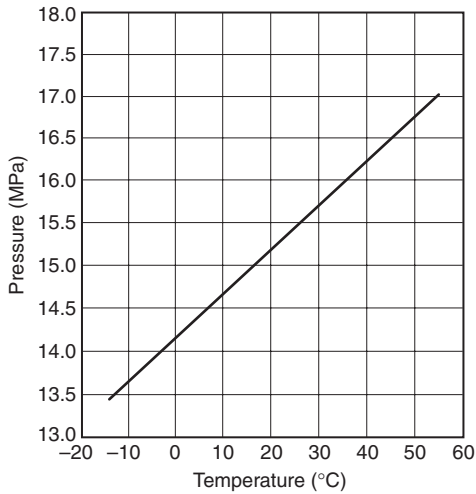

(3) Pressurized to 15 MPa at 21°C

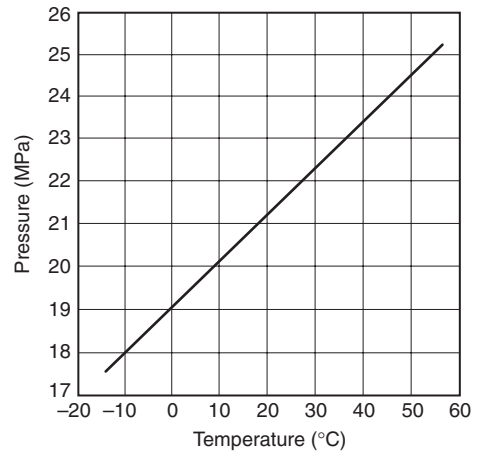

(4) Pressurized to 20 MPa at 15°C

FIGURE A.4.1.4.1(k) Isometric Diagram of IG-541.

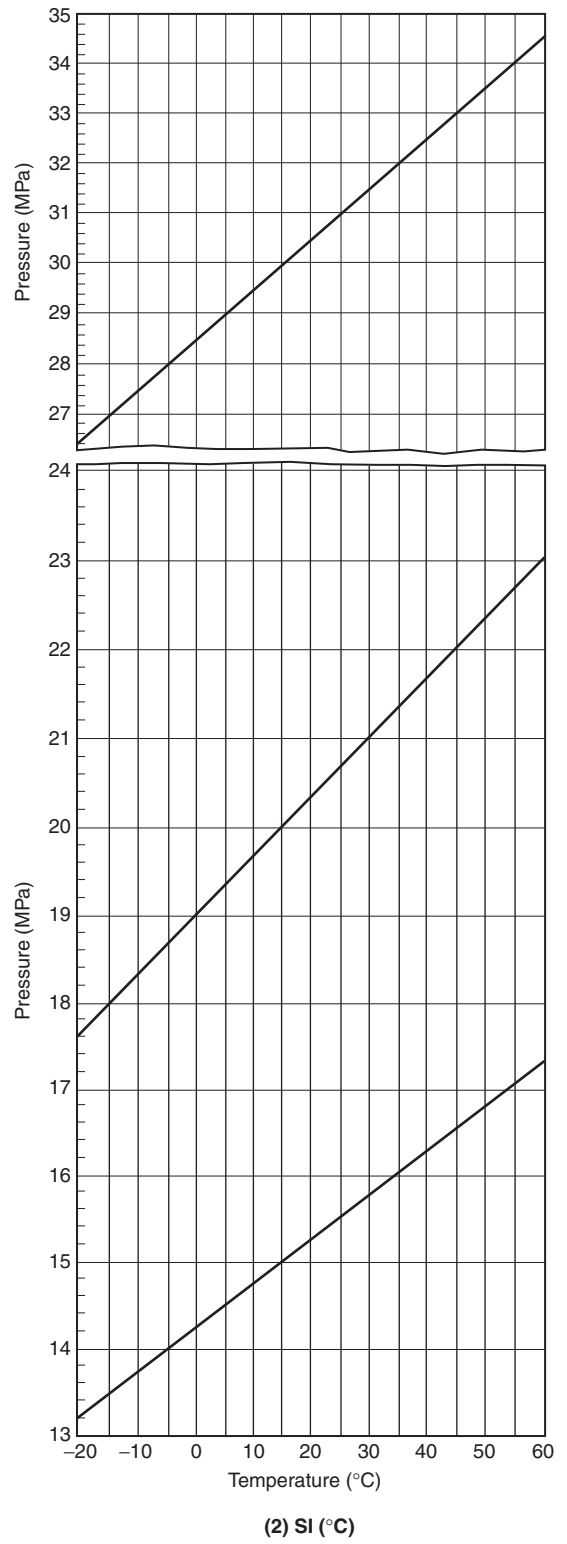
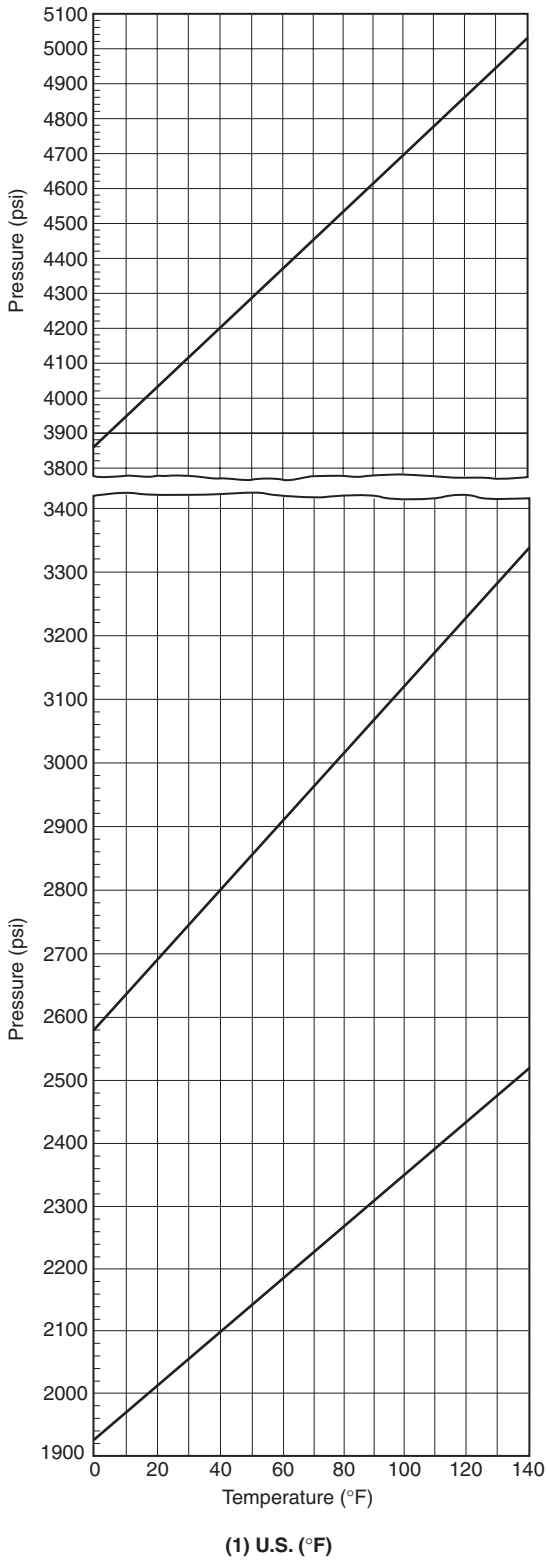

FIGURE A.4.1.4.1(l) Isometric Diagram of IG-55.

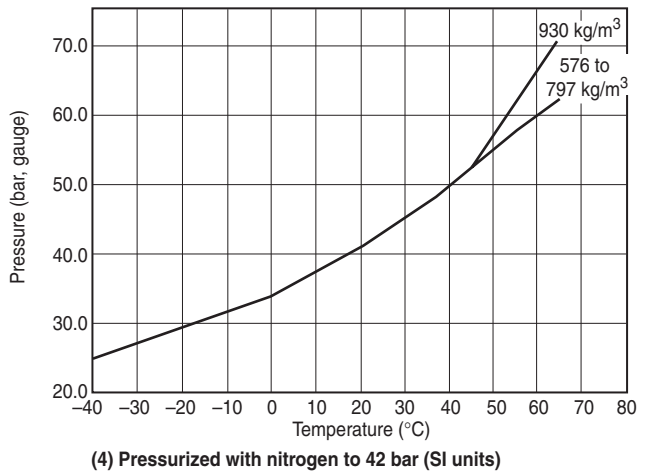
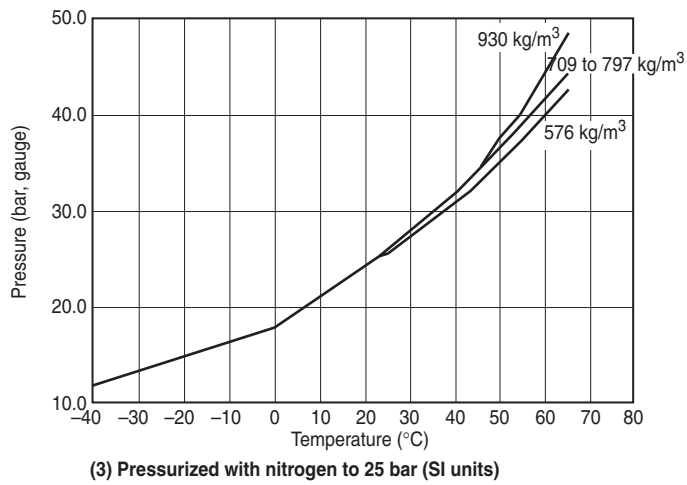
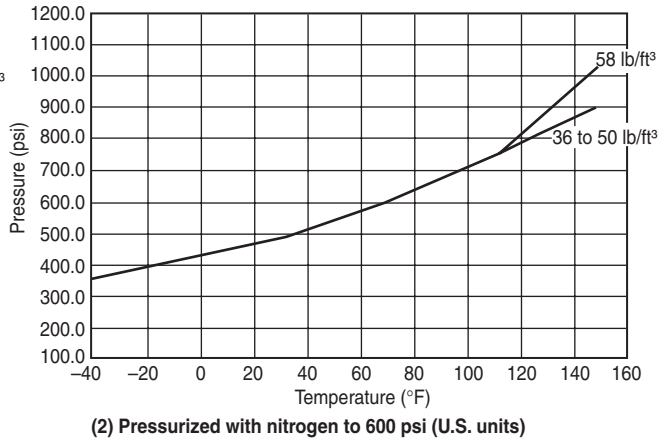
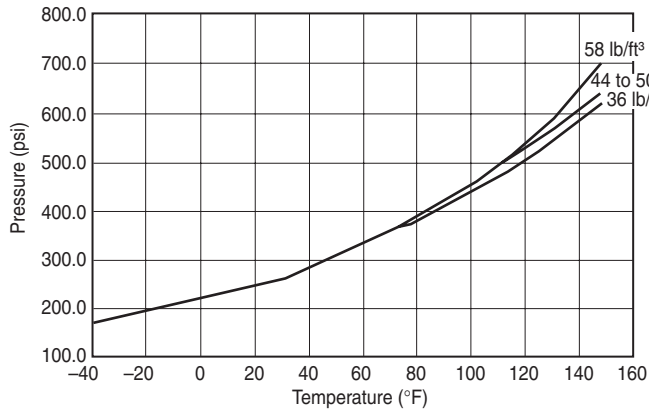

FIGURE A.4.1.4.1(m) Isometric Diagram of HFC Blend B.



Table A.4.1.4.1 Storage Container Characteristics

Extinguishing Agent	Maximum Fill Density for Conditions Listed Below (lb/ft ³)	Minimum Container Design Level Working Pressure (psig)	Total Pressure Level at 70°F (psig)
FK-5-1-12	90	500	360
HCFC Blend A	56.2	500	360
HCFC-124	71	240	195
HFC-125	58	320	166.4 ^a
HFC-227ea	72	500	360
HFC-23	54	1800	608.9 ^a
FIC-1311	104.7	500	360
IG-01	N/A	2120	2370
IG-100 (300)	N/A	3600	4061
IG-100 (240)	N/A	2879	3236
IG-100 (180)	N/A	2161	2404
IG-541	N/A	2015+	2175
IG-541 (200)	N/A	2746	2900
IG-55 (222)	N/A	2057+	2222 ^b
IG-55 (2962)	N/A	2743+	2962 ^c
IG-55 (4443)	N/A	4114+	4443 ^d
HFC Blend B	58	400	195 ^c

For SI units, 1 lb/ft³ = 16.018 kg/m³; 1 psig = 6895 Pa; temperature (°F) = [temperature (°C)]% + 32.

Notes:

(1) The maximum fill density requirement is not applicable for IG-541. Cylinders for IG-541 are DOT 3A or 3AA, are stamped 2015+, or greater.

(2) Total pressure level at 70°F (21°C) is calculated from the following filling conditions:

IG-100 (300): 4351 psig (30.0 MPa) and 95°F (35°C)

IG-100 (240): 3460 psig (23.9 MPa) and 95°F (35°C)

IG-100 (180): 2560 psig (17.7 MPa) and 95°F (35°C)

IG-55 (2222): 2175 psig (15 MPa) and 59°F (15°C)

IG-55 (2962): 2901 psig (20 MPa) and 59°F (15°C)

IG-55 (4443): 4352 psig (30 MPa) and 59°F (15°C)

^a Vapor pressure for HFC-23 and HFC-125.

^b Cylinders for IG-55 are stamped 2060+.

^c Cylinders for IG-55 are DOT 3A or 3AA stamped 2750+, or greater.

^d Cylinders for IG-55 are DOT 3A or 3AA stamped 4120+, or greater.

^e Vapor pressure of agent.

A.4.2.3.1 Fittings that are acceptable for use in clean agent systems can be found in Table A.4.2.3.1(a) and Table A.4.2.3.1(b). The fittings shown in these tables are based on use in open ended piping systems. For fittings used in closed sections of pipe, Sections 4 and 7 of the FSSA *Pipe Design Handbook* should be consulted.

Pressure-temperature ratings have been established for certain types of fittings. A list of ANSI standards covering the different types of fittings is given in Table 126.1 of ASME B31.1. Where fittings not covered by one of these standards are used, the design recommendations of the manufacturer of the fittings should not be exceeded.

A.4.2.4.2 Some of the new clean agents might not be compatible with the elastomers used in Halon 1301 system valves. Before charging a system container with some of the clean agents, it could be necessary to disassemble the discharge valve and completely replace the o-rings and other sealing surfaces with components that will not react to that agent. Make certain that this evaluation has been completed. Also make certain that the change results in the valve, container, and system complying with the appropriate listings or approvals.

A.4.3.2.1 The detection system selection process should evaluate the ambient environmental condition in determining the appropriate device and sensitivity in order to prevent unwanted discharges while still providing the necessary earliest actuation. In high air flow environments, air-sampling detection devices should be considered.

Detectors installed at the maximum spacing as listed or approved for fire alarm use can result in excessive delay in agent release, especially where more than one detection device is required to be in alarm before automatic actuation results.

Where there is a risk of forming a flammable atmosphere, the spacing and siting of flammable vapor detectors should be carefully considered to avoid excessive delay in agent release.

A.4.3.3.5.1 A discharge pressure switch can serve to initiate electrical functions that normally occur upon system actuation, such as shutdown functions and control panel actuation.

A.4.3.5.3 A telephone should be located near the abort switch.

A.4.3.5.6.1 Hazards associated with fast growth fires would include, but not be limited to, flammable liquid storage or transfer and aerosol filling areas.

Table A.4.2.3.1(a) Piping Systems Fittings

Clean Agent	Pressure in Agent Container at 70°F (21°C) (up to and including)	Fitting Minimum Design Pressure at 70°F (21°C) ^a	Minimum Acceptable Fittings	Maximum Pipe Size (NPS)
	psi (kPa)	psi (kPa)		
All halocarbon agents (except HFC-23)	360 (2,482)	416 (2,868)	Class 300 thrd. malleable iron	6 in.
			Class 300 thrd. ductile iron	6 in.
			Groove type fittings ^b	6 in.
	600 (4,137)	820 (5,654)	Class 300 flanged joints	All
			Class 300 thrd. malleable iron	4 in.
			Class 2,000 lb thrd./welded forged steel	All
HFC-23	609 (4,199)	1,371 (9,453) ^c	Class 400 flanged joint	All
			Class 300 thrd. malleable iron	2 in.
			Class 2,000 lb thrd./welded forged steel	All
IG-541	2,175 (14,997)	2,175 (14,997)	Class 600 flanged joint	All
			Class 2,000 lb thrd. forged steel	2½ in.
			Class 3,000 lb thrd./weld F.S.	All
	2,900 (19,996)	2,900 (19,996)	Class 1,500 flanged joint	All
			Upstream of the pressure reducer	— ^d
			Downstream of the pressure reducer ^d	— ^d
IG-01	2,370 (16,341)	2,370 (16,341)	Class 2,000 lb thrd. forged steel	1½ in.
			Class 3,000 lb thrd./weld F.S.	All
			Class 1,500 flanged joint	All
	2,964 (20,346)	2,964 (20,346)	Upstream of the pressure reducer	— ^d
			Downstream of the pressure reducer ^d	— ^d
			Class 2,000 lb thrd. forged steel	1 in.
IG-55	2,175 (14,997)	2,175 (14,997)	Class 3,000 lb thrd./weld F.S.	All
			Class 1,500 flanged joint	All
			Upstream of the pressure reducer	— ^d
	2,900 (19,996)	2,900 (19,996)	Downstream of the pressure reducer ^d	— ^d
			Class 2,000 lb thrd. forged steel	1 in.
			Class 3,000 lb thrd./weld F.S.	All



Table A.4.2.3.1(a) *Continued*

Clean Agent	Pressure in Agent Container at 70°F (21°C) (up to and including)	Fitting Minimum Design Pressure at 70°F (21°C) ^a	Minimum Acceptable Fittings	Maximum Pipe Size (NPS)
	psi (kPa)	psi (kPa)		
IG-100	4,350 (29,993)	Upstream of the pressure reducer	Class 1,500 flanged joint	All
		Downstream of the pressure reducer ^d	— ^d	— ^d
	2,404 (16,575)	Upstream of the pressure reducer	Class 3,000 lb thrd. forged steel Class 6,000 lb thrd./weld F.S.	1 in. All
		Downstream of the pressure reducer ^d	Class 2,500 flanged joint	All
	3,236 (22,312)	Upstream of the pressure reducer	Class 2,000 lb thrd. forged steel Class 3,000 lb thrd./weld F.S.	1½ in. All
		Downstream of the pressure reducer ^d	Class 1,500 flanged joint	All
	4,061 (28,000)	Upstream of the pressure reducer	Class 2,000 lb thrd. forged steel Class 3,000 lb thrd./weld F.S.	¾ in. All
		Downstream of the pressure reducer ^d	Class 1,500 flanged joint	All
	4,061 (28,000)	Upstream of the pressure reducer	Class 3,000 lb thrd. forged steel Class 6,000 lb thrd./weld F.S.	1 in. All
		Downstream of the pressure reducer ^d	Class 2,500 flanged joint	All
	4,061 (28,000)	Upstream of the pressure reducer	Class 3,000 lb thrd. forged steel Class 6,000 lb thrd./weld F.S.	1 in. All
		Downstream of the pressure reducer ^d	Class 2,500 flanged joint	All

Notes:

- (1) All fitting ratings shown are based on open ended piping systems.
- (2) The materials in this table do not preclude the use of other materials and other types and style of fittings that satisfy the requirements of 4.2.3.1.
- (3) The pressure ratings of the forged steel threaded or welded fittings are based on the pressure equivalent of the numerical class of the fitting or on the pressure rating of ASTM A 106B, Grade B seamless steel pipe, whichever is higher.
- ^a Minimum design pressures taken from Table 4.2.1.1(a) and Table 4.2.1.1(b).
- ^b Check with grooved fitting manufacturers for pressure ratings.
- ^c This value good for all fill densities up to 48 lb/ft³.
- ^d The minimum design pressure, for fittings downstream of the pressure reducer, should be determined by system flow calculations. Acceptable pipe fittings for several values of pressures downstream of the pressure reducer can be found in Table A.4.2.3.1(b).

Table A.4.2.3.1(b) Piping Systems Fittings for Use in Inert Gas Systems Downstream of the Pressure Reducer

Maximum Pressure Downstream of the Pressure Reducer at 70°F (21°C) [up to and including psig (kPa)]	Minimum Acceptable Fittings	Maximum Pipe Size (NPS)
1,000 (6,895)	Class 300 thrd. malleable iron	4 in.
	Class 2,000 lb thrd./welded forged steel	All
	Class 3,000 lb thrd./welded forged steel	All
	Class 600 lb flanged joint	All
1,350 (9,308)	Class 300 thrd. malleable iron	2 in.
	Class 2,000 lb thrd./welded forged steel	All
	Class 3,000 lb thrd./welded forged steel	All
	Class 600 lb flanged joint	All
1,500 (10,343)	Class 300 thrd. malleable iron	2 in.
	Class 2,000 lb thrd./welded forged steel	All
	Class 3,000 lb thrd./welded forged steel	All
	Class 900 lb flanged joint	All
2,000 (13,790)	Class 300 thrd. malleable iron	1 in.
	Class 2,000 lb thrd./welded forged steel	All
	Class 3,000 lb thrd./welded forged steel	All
	Class 900 lb flanged joint	All

A.4.3.6 Accidental discharge can be a significant factor in unwanted clean agent emissions. Equipment lockout or service disconnects can be instrumental in preventing false discharges when the clean agent system is being tested or serviced. In addition, servicing of air-conditioning systems with the release of refrigerant aerosols, soldering, or turning electric plenum heaters on for the first time after a long period of idleness could trip the clean agent system. Where used, an equipment disconnect switch should be of the keyed-access type if external to the control panel or can be of the toggle type if within the locked control panel. Either type should announce at the panel when in the out-of-service mode. Written procedures should be established for taking the clean agent system out of service. Care should be taken to thoroughly evaluate and correct any factors that could result in unwanted discharges.

A.5.1.2.2(28) The term “specified pressure limit” as used in this paragraph is not intended to necessarily be the same as the enclosure pressure strength as would be determined by a structural engineering analysis. Rather, the “specified pressure limit” is a value determined or estimated with confidence to be less than the enclosure pressure strength.

A.5.2 The two types of system flow calculations are liquefied compressed gas flow calculations and inert gas flow calculations.

Liquefied compressed gas flow calculations. Analyzing the behavior of two-phase agents in pipelines is a complex process with numerous methods. Two calculation methods are commonly used by fire protection professionals. The first is based on modifications to the HFLOW Method (DiNunno et al., 1995) completed in 1994, and the other is based on enhancement to the work of Hesson (Hesson, 1953) in 1953. Only those calculation methods that have been listed or approved should be used for design purposes.

The modified HFLOW calculation method is based on major modifications by Elliot et al. (1984) of a calculation method called HFLOW developed by the Jet Propulsion Laboratory. The

revised method is capable of predicting the two-phase flow characteristics of clean agents based on their thermodynamics properties. This method can calculate the flow characteristics of fire suppression agents across the wide range of real engineering systems in reasonable time scales.

The following basic assumptions are made to simplify the methodology:

- (1) The conditions in the cylinder (pressure, temperature, and composition) are solely functions of the initial conditions and the outage fraction (fraction of the initial charge mass having left the cylinder). This assumption effectively ignores the effect on the cylinder energy balance of the increased kinetic energy of the fluid leaving the cylinder.
- (2) Quasi-steady flow exists. The average flow rate over a small time interval step is equal to the flow rate that would exist if the cylinder conditions were held steady during that time step.
- (3) The heat transferred from the pipe walls to the flowing fluid is often assumed to be insignificant.
- (4) The flow through the pipe network is homogeneous. Liquid and vapor flow through the piping is at the same velocity and evenly dispersed.

Calculation cannot be done without adequate manufacturer’s hardware data. This data includes dip tube and manifold equivalent lengths and nozzle discharge coefficients.

Required input data include cylinder volume, valve, dip tube equivalent lengths, agent mass and temperature, pipe length and diameter, elevation, fittings, nozzle area, and discharge coefficients. Output data for each node (pipe, cylinder, or nozzle) include pressure, temperature, component fraction, phase distribution, mass flow rate, and velocity.

Due to its complexity, the HFLOW method does not lend itself to hand calculation.

The modified Hesson calculation methodology is a two-phase flow method first developed by Hesson for calculating pressure



drop along a pipeline flowing carbon dioxide. Hesson adapted Bernoulli's equation for ease of use with compressible, two-phase flow. It was refined by H. V. Williamson and then Tom Wysocki (Wysocki, 1996) for use with Halon 1301 and other clean agents.

The two-phase flow method models the following three basic flow conditions for a liquefied compressed gas discharge from a storage container:

- (1) The initial transient discharge during which agent flows from the container and cools the pipe.
- (2) A quasi-steady state flow during which the agent is assumed to maintain a constant enthalpy (adiabatic) condition with constant mass flow rate.
- (3) The final transient discharge during which the two-phase liquid and vapor flow is replaced by an essentially vapor discharge as the storage container empties.

The pressure drop during the quasi-steady state flow is based on the work of Hesson. The transient conditions are modeled using standard thermodynamics. During testing of the two-phase methodology with Halon 1301, mechanical separation of the liquid and vapor phases due to centripetal forces was observed. This effect has been noted for every liquefied compressed gas tested to date. The effect is not predicted by thermodynamics but was inferred from test data and confirmed using ultra-high speed photography (HT Research Institute, 1973). To accurately predict the quantity of agent discharge from each nozzle in a system, empirical corrections based on the degree of flow split, orientation of the tee junction, component fraction, and phase distribution are developed for the specific liquefied compressed gas.

The pressure drop calculation for the quasi-steady state flow using Hesson's adaption of Bernoulli's equation can be done by hand. The calculation of transient conditions and the calculation of mechanical separation effects at tees, and their effect on pressure drop and quantity of agent discharged from each nozzle in an unbalanced system, requires many complex iterations. Manual calculation of these effects is not practical. Therefore, a listed and approved computer program must be used for a complete calculation.

Required input data include cylinder volume, agent mass and temperature, valve and dip tube equivalent lengths, pipe lengths, elevation changes, fittings, and pre-discharge pipe temperature. Most programs permit the user to specify either the required flow rate or agent quantity for each nozzle or the "as-built" system condition. If flow rate or agent quantity is specified, the program will calculate the required pipe and nozzle diameters. If an "as-built" condition including pipe and nozzle diameters is specified, the program calculates system flow rates. In either case, pressure drop, discharge time, and quantity discharged from each nozzle is reported.

Inert gas flow calculations. Inert gases present a problem in single-phase compressible flow. Many fluid dynamics handbooks provide formulas for compressible gas flow that can be suitable for relatively simple pipe networks with short lengths of pipe. These formulas are inadequate to calculate systems using longer pipe lengths with complex configurations. Wysocki and Christensen (Wysocki et al., 1996) adapted the work of Hesson for use with single-phase compressible gases.

Inert gas discharge from a cylinder into a pipe and nozzle network involves the following three stages:

- (1) The initial transient phase as the gas flows into the pipe and fills the pipe up to the nozzles. There is a marked variation between the time at which various nozzles in an unbalanced pipe network begin discharging agent.

- (2) Full flow during which all nozzles discharge agent. This is a dynamic condition during which the flow rates, agent temperatures, and pressure conditions constantly change.
- (3) Final transient condition during which the storage container and pipeline empty. Complex changes in flow rates at the individual nozzles take place.

Flow in these systems is neither adiabatic nor isothermal (the two classical limits). The complexity of the calculation for large, unbalanced pipe networks necessitates use of a listed or approved computer program.

Regardless of the method used for flow calculations, certain limits are established during the listing and approval process for the flow calculation. Typical limits include the following:

- (1) Limit arc degree of split at tees
- (2) Limits on the orientation of tees
- (3) Limits on agent arrival time
- (4) Limits on agent "run out" or "end of liquid" time differences between nozzles
- (5) Minimum pressure limits
- (6) Minimum flow density limits
- (7) Maximum and minimum storage container fill density limits
- (8) Additional limits specific to the flow calculation program

The results of the calculation must be checked to verify that limits have not been exceeded. Computerized calculations generally report warning or error messages if the system falls outside program limits.

A.5.2.1 A listed or approved calculation method should predict agent mass discharged per nozzle, average nozzle pressure, and system discharge time within the following limits of accuracy:

- (1) The mass of agent predicted to discharge from a nozzle by the flow calculation method should agree with mass of agent measured from the nozzle by -10 percent to $+10$ percent of the predicted value. A standard deviation of the percentage differences between measured and predicted nozzle agent quantities, relative to zero, should not be greater than 5 percent.
- (2) The system discharge time predicted by the flow calculation method should agree with the actual system discharge time value or by ± 1 second for halocarbon systems, or ± 10 seconds for inert gas systems, whichever is greater.
- (3) The average nozzle pressures predicted by the flow calculation method should agree with the actual nozzle pressures by -10 percent to $+10$ percent of the predicted value.
- (4) The nozzle pressure should not fall below the minimum or above the maximum nozzle pressure required for the nozzle to uniformly distribute the agent throughout the volume which that nozzle's discharge is to protect.

A.5.3.5 Examples of ventilation systems necessary to ensure safety include cooling of vital equipment required for process safety and ventilation systems required for containment of hazardous materials. Where recirculating ventilation is not shut off, additional agent could be needed to compensate for room leakage during the hold time.

A.5.3.6 Enclosure pressures developed during the discharge of a clean agent system are dependent on many variables, including factors unique to each agent, system, and enclosure. Over- or underpressurization of the enclosure can occur during the discharge.

A.5.4.2 This standard requires that the flame extinguishing concentration of a gaseous agent for a Class B fuel be determined by the cup burner method. Cup burner testing in the past has involved a variety of techniques, apparatus, and investigators. It was reported by Senecal (Senecal, 2004) that significant inconsistencies are apparent in Class B flame extinguishing data for inert gases presently appearing in use in national and international standards. In 2003 the NFPA 2001 Technical Committee appointed a task group to develop an improved cup burner test method. The degree of standardization of the cup burner test method has been significantly improved and appears for the first time in Annex B of the 2008 revision of this document. A standard cup burner test procedure with defined apparatus has now been established and is outlined in Annex B. Values of minimum flame extinguishing concentration (MEC) for gaseous agents addressed in this standard, as determined by the revised test method, are given in Table A.5.4.2(a). Retained in the 2008 edition of this standard are values of MEC reported in the 2004 edition for the purpose of providing an MEC reference where data obtained by the revised test method is not available at the time of approval and adoption of the 2008 edition. It is intended that in subsequent editions the 2004 MEC data can be deleted.

Table A.5.4.2(b) presents cup burner flame extinguishing concentrations for n-heptane.

A.5.4.2.2 The following details the fire extinguishment/area coverage fire test procedure for engineered and pre-engineered clean agent extinguishing system units.

- (1) The general requirements are as follows:
 - (a) An engineered or pre-engineered extinguishing system should mix and distribute its extinguishing agent and should totally flood an enclosure when tested in accordance with the recommendations of A.5.4.2.2(1)(c) through A.5.4.2.2(6)(f) under the maximum design limitations and most severe installation instructions. See also A.5.4.2.2(1)(b).

Table A.5.4.2(a) Minimum Flame Extinguishing Concentration (MEC, percent by volume Fuel: n-heptane)

Agent	By 2004 Test Method	By 2008 Test Method
FIC-1311*	3.2	TBD
FK-5-1-12	4.5	TBD
HCFC Blend A	9.9	TBD
HCFC-124	6.6	TBD
HFC-125	8.7	TBD
HFC-227ea	6.6(1)	TBD
HFC-23	12.9	TBD
HFC-236fa	6.3	TBD
IG-01	42	TBD
IG-100*	31(2)	TBD
IG-541	31	TBD
IG-55	35	TBD

Note: A value of cup burner extinguishing concentration of 6.7 percent for HCF-227ea for commercial heptane fuel.

*Not derived from standardized cup burner method.

Table A.5.4.2(b) n-Heptane Cup Burner Extinguishment Concentrations

Agent	Cup Burner Value
FIC-1311*	3.2
FK-5-1-12	4.5
HCFC Blend A	9.9
HCFC-124	6.6
HFC-125	8.7
HFC-227ea	6.7
HFC-23	12.9
HFC-236fa	6.4
IG-01	42
IG-100*	31
IG-541	31
IG-55	35
HFC Blend B	11.3

Note: A value of cup burner extinguishing concentration of 6.7 percent for HCF-227ea for commercial heptane fuel.

*Not derived from standardized cup burner method.

- (b) When tested as described in A.5.4.2.2(2)(a) through A.5.4.2.2(5)(b), an extinguishing system unit should extinguish all fires within 30 seconds after the end of system discharge. When tested as described in A.5.4.2.2(2)(a) through A.5.4.2.2(3)(c) and A.5.4.2.2(6)(a) through A.5.4.2.2(6)(f), an extinguishing system should prevent reignition of the wood crib after a 10 minute soak period.
- (c) The tests described in A.5.4.2.2(2)(a) through A.5.4.2.2(6)(f) should be carried out. Consider the intended use and limitations of the extinguishing system, with specific reference to the following:
 - i. The area coverage for each type of nozzle
 - ii. The operating temperature range of the system
 - iii. Location of the nozzles in the protected area
 - iv. Either maximum length and size of piping and number of fittings to each nozzle or minimum nozzle pressure
 - v. Maximum discharge time
 - vi. Maximum fill density
- (2) The test enclosure construction is as follows:
 - (a) The enclosure for the test should be constructed of either indoor or outdoor grade minimum $\frac{3}{8}$ in. (9.5 mm) thick plywood or equivalent material.
 - (b) An enclosure(s) is to be constructed having the maximum area coverage for the extinguishing system unit or nozzle being tested and the minimum and maximum protected area height limitations.

The test enclosure(s) for the maximum height, flammable liquid, and wood crib fire extinguishment tests need not have the maximum coverage area, but should be at least 13.1 ft (4.0 m) wide by 13.1 ft (4.0 m) long and 3351 ft³ (100 m³) in volume.

- (3) The extinguishing system is as follows:
- A pre-engineered-type extinguishing system unit is to be assembled using its maximum piping limitations with respect to number of fittings and length of pipe to the discharge nozzles and nozzle configuration(s), as specified in the manufacturer's design and installation instructions.
 - An engineered-type extinguishing system unit is to be assembled using a piping arrangement that results in the minimum nozzle design pressure at 70°F (21°C).
 - Except for the flammable liquid fire test using the 2½ ft² (0.23 m²) square pan and the wood crib extinguishment test, the cylinders are to be conditioned to the minimum operating temperature specified in the manufacturer's installation instructions.
- (4) The extinguishing concentration is as follows:
- The extinguishing agent concentration for each test is to be 83.34 percent of the intended end use design concentration specified in the manufacturer's design and installation instructions at the ambient temperature of approximately 70°F (21°C) within the enclosure.
 - The concentration for inert gas clean agents can be adjusted to take into consideration actual leakage measured from the test enclosure.
 - The concentration within the enclosure for halocarbon clean agents should be calculated using the following formula unless it is demonstrated that the test enclosure exhibits significant leakage. If significant test enclosure leakage does exist, the formula used to determine the test enclosure concentration of halocarbon clean agents can be modified to account for the leakage measured.

$$W = \frac{V}{s} \left(\frac{C}{100 - C} \right)$$

where:

- W = weight of clean agents (lb)
 V = volume of test enclosure (ft³)
 s = specific volume of clean agent at test temperature (ft³/lb)
 C = concentration (percent)

- (5) The flammable liquid extinguishment tests are as follows:
- Steel test cans having a nominal thickness of 0.216 in. (5.5 mm), (such as Schedule 40 pipe) and 3.0 in. to 3.5 in. (76.2 mm to 88.9 mm) in diameter and at least 4 in. (102 mm) high, containing either heptane or heptane and water, are to be placed within 2 in. (50.8 mm) of the corners of the test enclosure(s) and directly behind the baffle, and located vertically within 12 in. (305 mm) of the top or bottom of the enclosure, or both top and bottom if the enclosure permits such placement. If the cans contain heptane and water, the heptane is to be at least 2 in. (50.8 mm) deep. The level of heptane in the cans should be at least 2 in. (50.8 mm) below the top of the can. For the minimum room height area coverage test, closable openings are provided directly above the cans to allow for venting prior to system installation. In addition, for the minimum height limitation area coverage test, a baffle is to be installed between the floor and ceiling in the center of the enclosure. The baffle is to be perpendicular to the direction of

nozzle discharge, and to be 20 percent of the length or width of the enclosure, whichever is applicable with respect to nozzle location. For the maximum room height extinguishment test, an additional test is to be conducted using a 2½ ft² (0.23 m²) square pan located in the center of the room and the storage cylinder conditioned to 70°F (21°C). The test pan is to contain at least 2 in. (50.8 mm) of heptane with the heptane level at least 2 in. (50.8 mm) below the top of the pan. For all tests the heptane is to be ignited and allowed to burn for 30 seconds, upon which time all openings are to be closed and the extinguishing system is to be manually actuated. At the time of actuation, the percent of oxygen within the enclosure should be at least 20 percent.

- The heptane is to be commercial grade having the following characteristics:
 - Initial BP: 90°C (194°F) minimum
 - Dry point: 100°C (212°F) maximum
 - Specific gravity: 0.69–0.73
- (6) The wood crib extinguishment tests are as follows:
- The storage cylinder is to be conditioned to 70°F (21°C). The test enclosure is to have the maximum ceiling height as specified in the manufacturer's installation instructions.
 - The wood crib is to consist of four layers of six, trade size 2 by 2 (1½ by 1½ in.) by 18 in. long, kiln spruce or fir lumber having a moisture content between 9 and 13 percent. The alternate layers of the wood members are to be placed at right angles to one another. The individual wood members in each layer are to be evenly spaced, forming a square determined by the specified length of the wood members. The wood members forming the outside edges of the crib are to be stapled or nailed together.
 - Ignition of the crib is to be achieved by the burning of commercial grade heptane in a square steel pan 2½ ft² (0.23 m²) in area and not less than 4 in. (101.6 mm) in height. The crib is to be centered with the bottom of the crib 12 to 24 in. (304 to 609.6 mm) above the top of the pan and the test stand constructed so as to allow for the bottom of the crib to be exposed to the atmosphere.
 - The heptane is to be ignited, and the crib is to be allowed to burn freely for approximately 6 minutes outside the test enclosure. The heptane fire is to burn for 3 to 3½ minutes. Approximately ¼ gal (0.95 L) of heptane will provide a 3 to 3½ minute burn time. Just prior to the end of the pre-burn period, the crib is to be moved into the test enclosure and placed on a stand such that the bottom of the crib is between 20 and 28 in. (508 and 711 mm) above the floor. The closure is then to be sealed.
 - After the crib is allowed to burn for a period of 6 minutes, the system is to be actuated. At the time of actuation, the percent of oxygen within the enclosure at the level of the crib should be at least 20 percent.
 - After the end of system discharge, the enclosure is to remain sealed for a total of 10 minutes. After the 10 minute soak period, the crib is to be removed from the enclosure and observed to determine whether sufficient fuel remains to sustain combustion, and to detect signs of reignition.

(7) The following is a schematic of the process to determine the design quantity:

- (a) Determine hazard features, as follows:
- Fuel type: Extinguishing concentration (EC) per 5.4.2 or inerting concentration (IC) per 5.4.3
 - Enclosure volume
 - Enclosure temperature
 - Enclosure barometric pressure

- (b) Determine the agent minimum design concentration (MDC) by multiplying EC or IC by the safety factor (SF), therefore:

$$\text{MDC} = (\text{EC or IC}) \text{ SF}$$

- (c) Determine the agent minimum design quantity (MDQ) by referring to 5.5.1 for halocarbons or 5.5.2 for inert gases

- (d) Determine whether design factors (DF) apply. See 5.5.3 to determine individual DF(i)s and then determine sum. Therefore:

$$\text{DF} = \Sigma \text{DF}(i)s$$

- (e) Determine the agent adjusted minimum design quantity (AMDQ) as follows:

$$\text{AMDQ} = \text{MDQ} (1 + \text{DF})$$

- (f) Determine the pressure correction factor (PCF) per 5.5.3.3

- (g) Determine the final design quantity (FDQ) as follows:

$$\text{FDQ} = \text{AMDQ} \times \text{PCF}$$

Where any of the following conditions exist, higher extinguishing concentrations might be required:

- Cable bundles greater than 100 mm in diameter
- Cable trays with a fill density greater than 20 percent of the tray cross-section
- Horizontal or vertical stacks of cable trays (closer than 250 mm)
- Equipment energized during the extinguishment period where the collective power consumption exceeds 5 kW

Fire Extinguishment Test (Noncellulosic) Class A Surface Fires. The purpose of the tests outlined in this procedure is to develop the minimum extinguishing concentration (MEC) for a gaseous fire suppression agent for a range of noncellulosic, solid polymeric combustibles. It is intended that the MEC will be increased by appropriate safety factors and flooding factors as provided for in the standard.

These Class A tests should be conducted in a draft-free room with a volume of at least 100 m³ and a minimum height of 3.5 m and each wall at least 4 m long. Provisions should be made for relief venting if required.

The test objects are as follows:

- The polymer fuel array consists of 4 sheets of polymer, 9.5 mm thick, 406 mm tall, and 203 mm wide. Sheets are spaced and located per Figure A.5.4.2.2(a). The bottom of the fuel array is located 203 mm from the floor. The fuel sheets should be mechanically fixed at the required spacing.

- A fuel shield consisting of a metal frame with sheet steel on the top and two sides is provided around the fuel array as indicated in Figure A.5.4.2.2(a). The fuel shield is 381 mm wide, 851 mm high, and 610 mm deep. The 610 mm wide × 851 mm high sides and the 610 mm × 381 mm top are sheet steel. The remaining two sides and the bottom are open. The fuel array is oriented in the fuel shield such that the 203 mm dimension of the fuel array is parallel to the 610 mm side of the fuel shield.

- Two external baffles measuring 0.95 m² and 305 mm tall are located around the exterior of the fuel shield as shown in Figure A.5.4.2.2(b). The baffles are placed 89 mm above the floor. The top baffle is rotated 45 degrees with respect to the bottom baffle.

- Tests are conducted for three plastic fuels — polymethyl methacrylate (PMMA), polypropylene (PP), and acrylonitrile-butadiene-styrene polymer (ABS). Plastic properties are given in Table A.5.4.2.2(a).

- The ignition source is a heptane pan 51 mm × 51 mm × 22 mm deep centered 12 mm below the bottom of the plastic sheets. The pan is filled with 3.0 ml of heptane to provide 90 seconds of burning.

- The agent delivery system should be distributed through an approved nozzle. The system should be operated at the minimum nozzle pressure (±10 percent) and the maximum discharge time (±1 second).

The test procedure is as follows:

- The procedures for ignition are as follows:
 - The heptane pan is ignited and allowed to burn for 90 seconds.
 - The agent is discharged 210 seconds after ignition of heptane.
 - The compartment remains sealed for 600 seconds after the end of discharge. Extinguishment time is noted. If the fire is not extinguished within 600 seconds of the end of agent discharge, a higher minimum extinguishing concentration must be utilized.
 - The test is repeated two times for each fuel for each concentration evaluated and the extinguishment time averaged for each fuel. Any one test with an extinguishment time above 600 seconds is considered a failure.
 - If the fire is extinguished during the discharge period, the test is repeated at a lower concentration or additional baffling provided to ensure that local transient discharge effects are not impacting the extinguishment process.
 - At the beginning of the tests, the oxygen concentration must be within 2 percent (approximately 0.5 percent by volume O₂) of ambient value.
 - During the post-discharge period, the oxygen concentration should not fall below 0.5 percent by volume of the oxygen level measured at the end of agent discharge.
- The observation and recording procedures are as follows:
 - The following data must be continuously recorded during the test:
 - Oxygen concentration (±0.5 percent)
 - Fuel mass loss (±5 percent)
 - Agent concentration (±5 percent) (Inert gas concentration can be calculated based on oxygen concentration.)



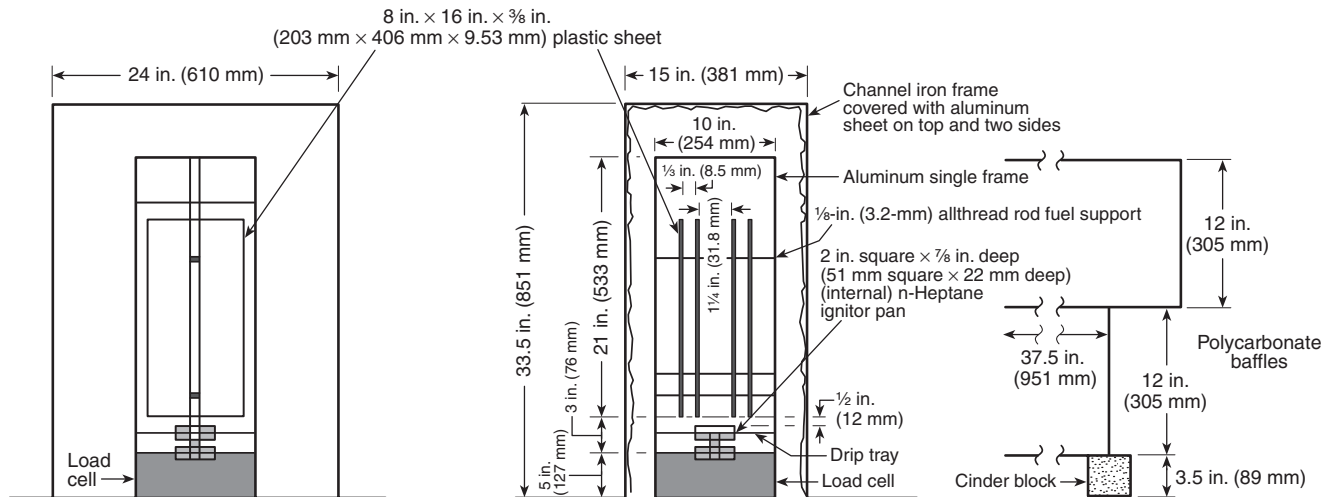

FIGURE A.5.4.2.2(a) Four Piece Modified Plastic Setup.

- (b) The following event is timed and recorded:
- i. Time at which heptane is ignited
 - ii. Time of heptane pan burn out
 - iii. Time of plastic sheet ignition
 - iv. Time of beginning of agent discharge
 - v. Time of end of agent discharge
 - vi. Time all visible flame is extinguished

The minimum extinguishing concentration is determined by all of the following conditions:

- (1) All visible flame extinguished within 600 seconds of agent discharge.
- (2) The fuel weight loss between 10 seconds and 600 seconds after the end of discharge should not exceed 0.5 oz (15 g).
- (3) No ignition of the fuel at the end of the 600 second soak time and subsequent test compartment ventilation.

Deep-seated fires involving Class A fuels can require substantially higher design concentrations and extended holding times than the design concentrations and holding times required for surface-type fires involving Class A fuels. Wood crib and polymeric sheet Class A fire tests may not adequately indicate extinguishing concentrations suitable for the protection of certain plastic fuel hazards (e.g., electrical and electronic type hazards involving grouped power or data cables such as computer and control room underfloor voids, telecommunication facilities, etc.).

The values in Table A.5.4.2.2(b) are representative of the minimum extinguishing concentrations and design concentrations for various agents. The concentrations required can vary by manufacturer of equipment. The equipment manufacturer should be contacted for the concentration required for their specific system.

A.5.4.2.4 Hazards containing both Class A and Class B fuels should be evaluated on the basis of the fuel requiring the highest design concentration.

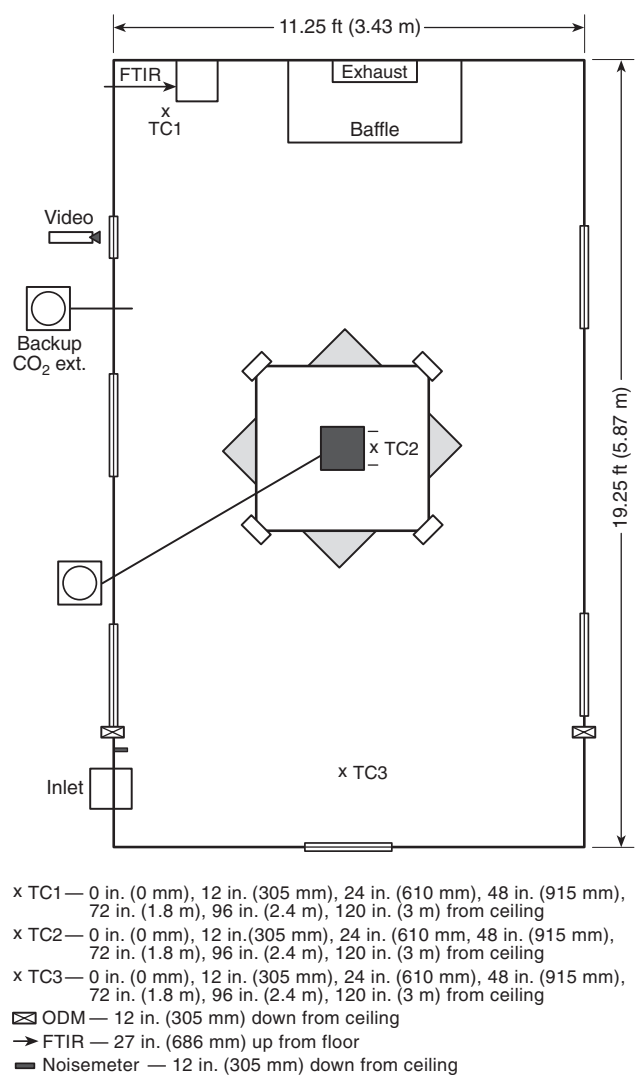

FIGURE A.5.4.2.2(b) Chamber Plan View.

Table A.5.4.2.2(a) Plastic Fuel Properties

25 kW/m ² Exposure in Cone Calorimeter — ASTM E 1354								
Fuel	Color	Density (g/cm ³)	Ignition Time		180 Second Average Heat Release Rate		Effective Heat of Combustion	
			sec	Tolerance	kW/m ²	Tolerance	MJ/kg	Tolerance
PMMA	Black	1.19	77	± 30%	286	25%	23.3	± 15%
Polypropylene	Natural (White)	0.905	91	± 30%	225	25%	39.8	± 15%
ABS	Natural (Cream)	1.04	115	± 30%	484	25%	29.1	± 15%

Table A.5.4.2.2(b) Class A and B Flame Extinguishing and Minimum Design Concentrations Tested to UL 2166 and UL 2127

Agent	Class A MEC	Class A Design	Class B MEC	Class B Design
FK-5-1-12	3.5	4.2	4.5	5.9
HFC-125	6.7	8	8.7	11.3
HFC-227ea	5.2-5.8	6.25-7	6.7	8.7
IG-541	28.5	34.2	31.25	40.6
IG-55	31.6	37.9	30.1	39.1

Note: Concentrations reported are at 70°F (21°C). Class B values are for heptane, Class A design values are at a safety factor of 1.2, and Class B design values are at a safety factor of 1.3.

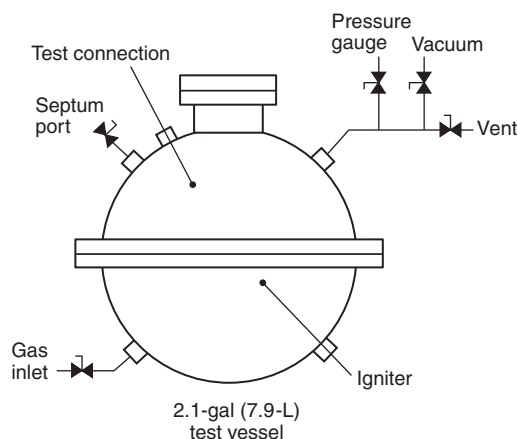

FIGURE A.5.4.3 Spherical Test Vessel.

A.5.4.3 This annex section provides a summary of a method of evaluating inerting concentration of a fire extinguishing vapor.

One characteristic of halons and replacement agents is frequently referred to as the inerting, or inhibiting, concentration. Related to this, flammability diagram data (Dalzell, 1975 and Coll, 1976) on ternary systems was published in NFPA 12A. The procedures used previously have been used more recently to evaluate inerting concentrations of halons and replacement chemicals against various fuel-air systems. Differences between the earlier studies and the recent work are that the test vessel volume used was 2.1 gal (7.9 L) versus 1.5 gal (5.6 L) previously. The igniter type was the same, that is, carbon rod corona discharge spark, but the capacitor-stored energy levels were higher, approximately 68 J (16.2 cal) versus 6 or 11 J (1.4 or 2.6 cal) in the earlier work. The basic procedure, employing a gap spark, has been adopted to develop additional data.

Ternary fuel-air agent mixtures were prepared at a test pressure of 1 atm and at room temperature in a 2.1 gal (7.9 L) spherical test vessel (see Figure A.5.4.3) by the partial pressure method. The vessel was fitted with inlet and vent ports, a thermocouple, and a pressure transducer. The test vessel was first evacuated. Agent was then admitted, and if a liquid, sufficient time was allowed for evaporation to occur. Fuel vapor and finally air were admitted, raising the vessel pressure to 1 atm. An internal flapper allowed the mixtures to be agitated by rocking the vessel back and forth. The pressure transducer was connected to a suitable recording device to measure pressure rise that could occur on actuation of the igniter.

The igniter employed consisted of a bundle of 4 graphite rods (“H” pencil leads) held together by 2 wire or metal band wraps on either end of the bundle leaving a gap between the wraps of about 0.12 in. (3 mm). The igniter was wired in series with two 525 mF 450 V capacitors. The capacitors were charged to a potential of 720 to 730 V dc. The stored energy was, therefore, 68 to 70 J (16.2 to 16.7 cal). The nominal resistance of the rod assembly was about 1 ohm. On switch closure the capacitor discharge current resulted in ionization at the graphite rod surface. A corona spark jumped across the connector gap. The spark energy content was taken as the stored capacitor energy — though, in principle, stored capacitor energy must be somewhat less than this amount due to line resistance losses.

The pressure rise, if any, resulting from ignition of the test mixture was recorded. The interior of the test vessel was wiped clean between tests with a cloth damp with either water or a solvent to avoid buildup of decomposition residues that could influence the results.

The definition of the flammable boundary was taken as that composition that just produces a pressure rise of 0.07 times the initial pressure, or 1 psi (6.9 kPa) when the initial pressure is 1 atm. Tests were conducted at fixed fuel-air ratios and varying amounts of agent vapor until conditions were found to give rise to pressure increases that bracket 0.07 times the initial pressure. Tests were conducted at several fuel-air ratios to establish that condition requiring the highest agent vapor concentration to inert.



Data obtained on several chemicals that can serve as fire protection agents are given in Table A.5.4.3.

A.5.4.3.2 These conditions are when both the following occur:

- (1) The types and quantity of fuel permitted in the enclosure has the potential to lead to development of a fuel vapor concentration equal to or greater than one-half of the lower flammable limit throughout the enclosure.
- (2) The system response is not rapid enough to detect and extinguish the fire before the volatility of the fuel is increased to a dangerous level as a result of the fire.

A.5.5.1 The amount of clean agent required to develop a given concentration will be greater than the final amount of agent in the same enclosure. In most cases, the clean agent

must be applied in a manner that promotes progressive mixing of the atmosphere. As the clean agent is injected, the displaced atmosphere is exhausted freely from the enclosure through small openings or through special vents. Some clean agent is therefore lost with the vented atmosphere, and the higher the concentration, the greater the loss of clean agent.

For the purposes of this standard, it is assumed that the clean agent–air mixture lost in this manner contains the final design concentration of the clean agent. This represents the worst case from a theoretical standpoint and provides a built-in safety factor to compensate for non-ideal discharge arrangements.

Table A.5.5.1(a) through Table A.5.5.1(r) provide the amount of clean agent needed to achieve design concentration.

Table A.5.4.3 Inerting Concentrations for Various Agents

Fuel	Agent	Inerting Concentration (vol %)	Reference
i-Butane	HFC-227ea	11.3	Robin
	HCFC Blend A	18.4	Moore
	IG-100	40	Zabetakis
1-Chloro-1,1-difluoroethane (HCFC-142b)	HFC-227ea	2.6	Robin
1,1-Difluoroethane (HFC-152a)	HFC-227ea	8.6	Robin
	HCFC Blend A	13.6	Moore
Difluoromethane (HFC-32)	HFC-227ea	3.5	Robin
	HCFC Blend A	8.6	Moore
Ethane	IF-100	44	Zabetakis
Ethylene oxide	HFC-227ea	13.6	Robin
Hexane	IF-100	42	Zabetakis
Methane	FK-5-1-12	8.8	Schmeer
	HFC-125	14.7	Senecal
	HFC-227ea	8	Robin
	HFC-23	20.2	Senecal
	HCFC Blend A	18.3	Moore
	IG-100	37	Zabetakis
	IG-541	43	Tamanini
Pentane	HFC-227ea	11.6	Robin
	IG-100	42	Zabetakis
Propane	FK-5-1-12	8.1	Schmeer
	FC-5-1-14	7.3	Senecal
	FIC-13I1	6.5	Moore
	HFC-125	15.7	Senecal
	HFC-227ea	11.6	Robin
	HFC-23	20.2	Senecal
	HFC-23	20.4	Skaggs
	HCFC Blend A	18.6	Moore
	IG-541	49.0	Tamanini
	IG-100	42	Zabetakis

Table A.5.5.1(a) FK-5-1-12 Total Flooding Quantity (U.S. Units)^a

Temp (<i>t</i>) (°F) ^c	Specific Vapor Volume (<i>s</i>) (ft ³ /lb) ^d	Weight Requirements of Hazard Volume, <i>W/V</i> (lb/ft ³) ^b							
		Design Concentration (% by Volume) ^e							
		3	4	5	6	7	8	9	10
-20	0.93678	0.0330	0.0445	0.0562	0.0681	0.0803	0.0928	0.1056	0.1186
-10	0.96119	0.0322	0.0433	0.0548	0.0664	0.0783	0.0905	0.1029	0.1156
0	0.9856	0.0314	0.0423	0.0534	0.0648	0.0764	0.0882	0.1003	0.1127
10	1.01001	0.0306	0.0413	0.0521	0.0632	0.0745	0.0861	0.0979	0.1100
20	1.03442	0.0299	0.0403	0.0509	0.0617	0.0728	0.0841	0.0956	0.1074
30	1.05883	0.0292	0.0394	0.0497	0.0603	0.0711	0.0821	0.0934	0.1049
40	1.08324	0.0286	0.0385	0.0486	0.0589	0.0695	0.0803	0.0913	0.1026
50	1.10765	0.0279	0.0376	0.0475	0.0576	0.0680	0.0785	0.0893	0.1003
60	1.13206	0.0273	0.0368	0.0465	0.0564	0.0665	0.0768	0.0874	0.0981
70	1.15647	0.0267	0.0360	0.0455	0.0552	0.0651	0.0752	0.0855	0.0961
80	1.18088	0.0262	0.0353	0.0446	0.0541	0.0637	0.0736	0.0838	0.0941
90	1.20529	0.0257	0.0346	0.0437	0.0530	0.0624	0.0721	0.0821	0.0922
100	1.22970	0.0252	0.0339	0.0428	0.0519	0.0612	0.0707	0.0804	0.0904
110	1.25411	0.0247	0.0332	0.0420	0.0509	0.0600	0.0693	0.0789	0.0886
120	1.27852	0.0242	0.0326	0.0412	0.0499	0.0589	0.0680	0.0774	0.0869
130	1.30293	0.0237	0.0320	0.0404	0.0490	0.0578	0.0667	0.0759	0.0853
140	1.32734	0.0233	0.0314	0.0397	0.0481	0.0567	0.0655	0.0745	0.0837
150	1.35175	0.0229	0.0308	0.0389	0.0472	0.0557	0.0643	0.0732	0.0822
160	1.37616	0.0225	0.0303	0.0382	0.0464	0.0547	0.0632	0.0719	0.0807
170	1.40057	0.0221	0.0297	0.0376	0.0456	0.0537	0.0621	0.0706	0.0793
180	1.42498	0.0217	0.0292	0.0369	0.0448	0.0528	0.0610	0.0694	0.0780
190	1.44939	0.0213	0.0287	0.0363	0.0440	0.0519	0.0600	0.0682	0.0767
200	1.47380	0.0210	0.0283	0.0357	0.0433	0.0511	0.0590	0.0671	0.0754
210	1.49821	0.0206	0.0278	0.0351	0.0426	0.0502	0.0580	0.0660	0.0742
220	1.52262	0.0203	0.0274	0.0346	0.0419	0.0494	0.0571	0.0650	0.0730

^a The manufacturer's listing specifies the temperature range for the operation.

^b *W/V* [agent weight requirements (lb/ft³)] = pounds of agent required per cubic foot of protected volume to produce indicated concentration at temperature specified.

$$W = \frac{V}{s} \left(\frac{C}{100 - C} \right)$$

^c *t* [temperature (°F)] = the design temperature in the hazard area.

^d *s* [specific volume (ft³/lb)] of superheated FK-5-1-12 vapor can be approximated by the formula:

$$s = 0.9856 + 0.002441t$$

where *t* is the temperature in °F.

^e *C* [concentration (%)] = volumetric concentration of FK-5-1-12 in air at the temperature indicated.



Table A.5.5.1(b) FK-5-1-12 Total Flooding Quantity (SI Units)^a

Temp (<i>t</i>) (°C) ^c	Specific Vapor Volume (<i>s</i>) (m ³ /kg) ^d	Weight Requirements of Hazard Volume, <i>W/V</i> (kg/m ³) ^b							
		Design Concentration (% by Volume) ^e							
		3	4	5	6	7	8	9	10
-20	0.0609140	0.5077	0.6840	0.8640	1.0479	1.2357	1.4275	1.6236	1.8241
-15	0.6022855	0.4965	0.6690	0.8450	1.0248	1.2084	1.3961	1.5879	1.7839
-10	0.0636570	0.4859	0.6545	0.8268	1.0027	1.1824	1.3660	1.5337	1.7455
-5	0.0650285	0.4756	0.6407	0.8094	0.9816	1.1575	1.3372	1.5209	1.7087
0	0.0664000	0.4658	0.6275	0.7926	0.9613	1.1336	1.3096	1.4895	1.6734
5	0.0677715	0.4564	0.6148	0.7766	0.9418	1.1106	1.2831	1.4593	1.6395
10	0.0691430	0.4473	0.6026	0.7612	0.9232	1.0886	1.2576	1.4304	1.6070
15	0.0705145	0.4386	0.5909	0.7464	0.9052	1.0674	1.2332	1.4026	1.5757
20	0.0718860	0.4302	0.5796	0.7322	0.8879	1.0471	1.2096	1.3758	1.5457
25	0.0732575	0.4222	0.5688	0.7184	0.8713	1.0275	1.1870	1.3500	1.5167
30	0.0746290	0.4144	0.5583	0.7052	0.8553	1.0086	1.1652	1.3252	1.4888
35	0.0760005	0.4069	0.5482	0.6925	0.8399	0.9904	1.1442	1.3013	1.4620
40	0.0773720	0.3997	0.5385	0.6802	0.8250	0.9728	1.1239	1.2783	1.4361
45	0.0787435	0.3928	0.5291	0.6684	0.8106	0.9559	1.1043	1.2560	1.4111
50	0.0801150	0.3860	0.5201	0.6570	0.7967	0.9395	1.0854	1.2345	1.3869
55	0.0814865	0.3795	0.5113	0.6459	0.7833	0.9237	1.0671	1.2137	1.3636
60	0.0828580	0.3733	0.5029	0.6352	0.7704	0.9084	1.0495	1.1936	1.3410
65	0.0842295	0.3672	0.4947	0.6249	0.7578	0.8936	1.0324	1.1742	1.3191
70	0.0856010	0.3613	0.4868	0.6148	0.7457	0.8793	1.0158	1.1554	1.2980
75	0.0869725	0.3556	0.4791	0.6052	0.7339	0.8654	0.9998	1.1372	1.2775
80	0.0883440	0.3501	0.4716	0.5958	0.7225	0.8520	0.9843	1.1195	1.2577
85	0.0897155	0.3447	0.4644	0.5866	0.7115	0.8390	0.9692	1.1024	1.2385
90	0.0910870	0.3395	0.4574	0.5778	0.7008	0.8263	0.9547	1.0858	1.2198
95	0.0924585	0.3345	0.4507	0.5692	0.6904	0.8141	0.9405	1.0697	1.2017
100	0.0938300	0.3296	0.4441	0.5609	0.6803	0.8022	0.9267	1.0540	1.1842

^a The manufacturer's listing specifies the temperature range for operation.

^b *W/V* [agent weight requirements (kg/m³)] = kilograms of agent required per cubic meter of protected volume to produce indicated concentration at temperature specified.

$$W = \frac{V}{s} \left(\frac{C}{100 - C} \right)$$

^c *t* [temperature (°C)] = the design temperature in the hazard area.

^d *s* [specific volume (m³/kg)] of superheated FK-5-1-12 vapor can be approximated by the formula:

$$s = 0.0664 + 0.0002741t$$

where *t* is the temperature in °C.

^e *C* [concentration (%)] = volumetric concentration of FK-5-1-12 in air at the temperature indicated.

Table A.5.5.1(c) HCFC Blend A Total Flooding Quantity (U.S. Units)^a

Temp (<i>t</i>) (°F) ^c	Specific Vapor Volume (<i>s</i>) (ft ³ /lb) ^d	Weight Requirements of Hazard Volume, <i>W/V</i> (lb/ft ³) ^b							
		Design Concentration (% by Volume) ^e							
		8.6	9	10	11	12	13	14	15
-50	3.2192	0.0292	0.0307	0.0345	0.0384	0.0424	0.0464	0.0506	0.0548
-40	3.2978	0.0285	0.0300	0.0337	0.0375	0.0414	0.0453	0.0494	0.0535
-30	3.3763	0.0279	0.0293	0.0329	0.0366	0.0404	0.0443	0.0482	0.0523
-20	3.4549	0.0272	0.0286	0.0322	0.0358	0.0395	0.0433	0.0471	0.0511
-10	3.5335	0.0261	0.0280	0.0314	0.035	0.0386	0.0423	0.0461	0.0499
0	3.6121	0.0260	0.0274	0.0308	0.0342	0.0378	0.0414	0.0451	0.0489
10	3.6906	0.0255	0.0268	0.0301	0.0335	0.0369	0.0405	0.0441	0.0478
20	3.7692	0.0250	0.0262	0.0295	0.0328	0.0362	0.0396	0.0432	0.0468
30	3.8478	0.0245	0.0257	0.0289	0.0321	0.0354	0.0388	0.0423	0.0459
40	3.9264	0.0240	0.0252	0.0283	0.0315	0.0347	0.0381	0.0415	0.0449
50	4.0049	0.0235	0.0247	0.0277	0.0309	0.0340	0.0373	0.0406	0.0441
60	4.0835	0.0230	0.0242	0.0272	0.0303	0.0334	0.0366	0.0399	0.0432
70	4.1621	0.0226	0.0238	0.0267	0.0297	0.0328	0.0359	0.0391	0.0424
80	4.2407	0.0222	0.0233	0.0262	0.0291	0.0322	0.0352	0.0384	0.0416
90	4.3192	0.0218	0.0229	0.0257	0.0286	0.0316	0.0346	0.0377	0.0409
100	4.3978	0.0214	0.0225	0.0253	0.0281	0.0310	0.0340	0.0370	0.0401
110	4.4764	0.0210	0.0221	0.0248	0.0276	0.0305	0.0334	0.0364	0.0394
120	4.5550	0.0207	0.0217	0.0244	0.0271	0.0299	0.0328	0.0357	0.0387
130	4.6336	0.0203	0.0213	0.0240	0.0267	0.0294	0.0322	0.0351	0.0381
140	4.7121	0.0200	0.0210	0.0236	0.0262	0.0289	0.0317	0.0345	0.0375
150	4.7907	0.0196	0.0206	0.0232	0.0258	0.0285	0.0312	0.0340	0.0368
160	4.8693	0.0193	0.0203	0.0228	0.0254	0.0280	0.0307	0.0334	0.0362
170	4.9479	0.0190	0.0200	0.0225	0.0250	0.0276	0.0302	0.0329	0.0357
180	5.0264	0.0187	0.0197	0.0221	0.0246	0.0271	0.0297	0.0324	0.0351
190	5.1050	0.0184	0.0194	0.0218	0.0242	0.0267	0.0293	0.0319	0.0346
200	5.1836	0.0182	0.0191	0.0214	0.0238	0.0263	0.0288	0.0314	0.0340

^a The manufacturer's listing specifies the temperature range for operation.

^b *W/V* [agent weight requirements (lb/ft³)] = pounds of agent required per cubic foot of protected volume to produce indicated concentration at temperature specified.

$$W = \frac{V}{s} \left(\frac{C}{100 - C} \right)$$

^c *t* [temperature (°F)] = the design temperature in the hazard area.

^d *s* [specific volume (ft³/lb)] = specific volume of superheated HCFC Blend A vapor can be approximated by the formula:

$$s = 3.612 + 0.0079t$$

where *t* = temperature (°F).

^e *C* [concentration (%)] = volumetric concentration of HCFC Blend A in air at the temperature indicated.



Table A.5.5.1(d) HCFC Blend A Total Flooding Quantity (SI Units)^a

Temp(<i>t</i>) (°C) ^c	Specific Vapor Volume(<i>s</i>) (m ³ /kg) ^d	Weight Requirements of Hazard Volume, <i>W/V</i> (kg/m ³) ^b							
		Design Concentration (% by Volume) ^e							
		8.6	9	10	11	12	13	14	15
-50	0.1971	0.4774	0.5018	0.5638	0.6271	0.6919	0.7582	0.8260	0.8954
-45	0.2015	0.4669	0.4908	0.5514	0.6134	0.6767	0.7415	0.8079	0.8758
-40	0.2059	0.4569	0.4803	0.5396	0.6002	0.6622	0.7256	0.7906	0.8570
-35	0.2103	0.4473	0.4702	0.5283	0.5876	0.6483	0.7104	0.7740	0.8390
-30	0.2148	0.4381	0.4605	0.5174	0.5755	0.6350	0.6958	0.7580	0.8217
-25	0.2192	0.4293	0.4513	0.507	0.5639	0.6222	0.6818	0.7428	0.8052
-20	0.2236	0.4208	0.4423	0.497	0.5528	0.6099	0.6683	0.7281	0.7893
-15	0.2280	0.4127	0.4338	0.4873	0.5421	0.5981	0.6554	0.7140	0.7740
-10	0.2324	0.4048	0.4255	0.4781	0.5318	0.5867	0.6429	0.7004	0.7593
-5	0.2368	0.3973	0.4176	0.4692	0.5219	0.5758	0.6309	0.6874	0.7451
0	0.2412	0.3900	0.4100	0.4606	0.5123	0.5652	0.6194	0.6748	0.7315
5	0.2457	0.3830	0.4026	0.4523	0.5031	0.5551	0.6083	0.6627	0.7183
10	0.2501	0.3762	0.3955	0.4443	0.4942	0.5453	0.5975	0.6510	0.7057
15	0.2545	0.3697	0.3886	0.4366	0.4856	0.5358	0.5871	0.6397	0.6934
20	0.2589	0.3634	0.3820	0.4291	0.4774	0.5267	0.5771	0.6288	0.6816
25	0.2633	0.3573	0.3756	0.422	0.4694	0.5178	0.5675	0.6182	0.6702
30	0.2677	0.3514	0.3694	0.415	0.4616	0.5093	0.5581	0.6080	0.6591
35	0.2722	0.3457	0.3634	0.4083	0.4541	0.5010	0.5490	0.5981	0.6484
40	0.2766	0.3402	0.3576	0.4017	0.4469	0.4930	0.5403	0.5886	0.6381
45	0.2810	0.3349	0.3520	0.3954	0.4399	0.4853	0.5318	0.5793	0.6280
50	0.2854	0.3297	0.3465	0.3893	0.4331	0.4778	0.5236	0.5704	0.6183
55	0.2898	0.3247	0.3412	0.3834	0.4265	0.4705	0.5156	0.5617	0.6089
60	0.2942	0.3198	0.3361	0.3776	0.4201	0.4634	0.5078	0.5533	0.5998
65	0.2987	0.3151	0.3312	0.372	0.4138	0.4566	0.5003	0.5451	0.5909
70	0.3031	0.3105	0.3263	0.3666	0.4078	0.4499	0.4930	0.5371	0.5823
75	0.3075	0.3060	0.3216	0.3614	0.4020	0.4435	0.4860	0.5294	0.5739
80	0.3119	0.3017	0.3171	0.3562	0.3963	0.4372	0.4791	0.5219	0.5658
85	0.3163	0.2975	0.3127	0.3513	0.3907	0.4311	0.4724	0.5146	0.5579
90	0.3207	0.2934	0.3084	0.3464	0.3854	0.4252	0.4659	0.5076	0.5502
95	0.3251	0.2894	0.3042	0.3417	0.3801	0.4194	0.4596	0.5007	0.5427

^a The manufacturer's listing specifies the temperature range for operation.

^b W/V [agent weight requirements (kg/m³)] = kilograms required per cubic meter of protected volume to produce indicated concentration at temperature specified.

$$W = \frac{V}{s} \left(\frac{C}{100 - C} \right)$$

^c t [temperature (°C)] = the design temperature in the hazard area.

^d s [specific volume (m³/kg)] = specific volume of superheated HCFC Blend A vapor can be approximated by the formula:

$$s = 0.2413 + 0.00088t$$

where t = temperature (°C).

^e C [concentration (%)] = volumetric concentration of HCFC Blend A in air at the temperature indicated.

Table A.5.5.1(e) HCFC-124 Total Flooding Quantity (U.S. Units)^a

Temp (<i>t</i>) (°F) ^c	Specific Vapor Volume (<i>s</i>) (ft ³ /lb) ^d	Weight Requirements of Hazard Volume, <i>W/V</i> (lb/ft ³) ^b							
		Design Concentration (% by Volume) ^e							
		5	6	7	8	9	10	11	12
20	2.4643	0.0214	0.0259	0.0305	0.0353	0.0401	0.0451	0.0502	0.0553
30	2.5238	0.0209	0.0253	0.0298	0.0345	0.0392	0.0440	0.0490	0.0540
40	2.5826	0.0204	0.0247	0.0291	0.0337	0.0383	0.0430	0.0479	0.0528
50	2.6409	0.0199	0.0242	0.0285	0.0329	0.0374	0.0421	0.0468	0.0516
60	2.6988	0.0195	0.0237	0.0279	0.0322	0.0366	0.0412	0.0458	0.0505
70	2.7563	0.0191	0.0232	0.0273	0.0315	0.0359	0.0403	0.0448	0.0495
80	2.8136	0.0187	0.0227	0.0268	0.0309	0.0352	0.0395	0.0439	0.0485
90	2.8705	0.0183	0.0222	0.0262	0.0303	0.0345	0.0387	0.0431	0.0475
100	2.9272	0.0180	0.0218	0.0257	0.0297	0.0338	0.0380	0.0422	0.0466
110	2.9837	0.0176	0.0214	0.0252	0.0291	0.0331	0.0372	0.0414	0.0457
120	3.0400	0.0173	0.0210	0.0248	0.0286	0.0325	0.0365	0.0407	0.0449
130	3.0961	0.0170	0.0206	0.0243	0.0281	0.0319	0.0359	0.0399	0.0440
140	3.1520	0.0167	0.0203	0.0239	0.0276	0.0314	0.0353	0.0392	0.0433
150	3.2078	0.0164	0.0199	0.0235	0.0271	0.0308	0.0346	0.0385	0.0425
160	3.2635	0.0161	0.0196	0.0231	0.0266	0.0303	0.0340	0.0379	0.0418
170	3.3191	0.0159	0.0192	0.0227	0.0262	0.0298	0.0335	0.0372	0.0411
180	3.3745	0.0156	0.0189	0.0223	0.0258	0.0293	0.0329	0.0366	0.0404
190	3.4298	0.0153	0.0186	0.0219	0.0254	0.0288	0.0324	0.0360	0.0398
200	3.4850	0.0151	0.0183	0.0216	0.0250	0.0284	0.0319	0.0355	0.0391

^a The manufacturer's listing specifies the temperature range for operation.

^b *W/V* [agent weight requirements (lb/ft³)] = pounds of agent required per cubic foot of protected volume to produce indicated concentration at temperature specified.

$$W = \frac{V}{s} \left(\frac{C}{100 - C} \right)$$

^c *t* [temperature (°F)] = The design temperature in the hazard area.

^d *s* [specific volume (ft³/lb)] = of superheated HCFC-124 vapor can be approximated by the formula:

$$s = 2.3580 + 0.0057t$$

where *t* = temperature in °F.

^e *C* [concentration (%)] = Volumetric concentration of HCFC-124 in air at the temperature indicated.



Table A.5.5.1(f) HCFC-124 Total Flooding Quantity (SI Units)^a

Temp(<i>t</i>) (°C) ^c	Specific Vapor Volume(<i>s</i>) (m ³ /kg) ^d	Weight Requirements of Hazard Volume, <i>W/V</i> (kg/m ³) ^b							
		Design Concentration (% by Volume) ^e							
		5	6	7	8	9	10	11	12
-10	0.1516	0.3472	0.4210	0.6524	0.5736	0.6524	0.7329	0.8153	0.1346
-5	0.1550	0.3396	0.4119	0.6382	0.5612	0.6382	0.7170	0.7976	0.1317
0	0.1583	0.3325	0.4032	0.6248	0.5493	0.6248	0.7019	0.7808	0.1289
5	0.1616	0.3257	0.3950	0.6120	0.5381	0.6120	0.6876	0.7649	0.1263
10	0.1649	0.3192	0.3872	0.5999	0.5274	0.5999	0.6739	0.7497	0.1238
15	0.1681	0.3131	0.3797	0.5883	0.5172	0.5883	0.6609	0.7352	0.1214
20	0.1714	0.3071	0.3725	0.5772	0.5074	0.5772	0.6484	0.7213	0.1191
25	0.1746	0.3015	0.3656	0.5665	0.4981	0.5665	0.6364	0.7080	0.1169
30	0.1778	0.2960	0.3590	0.5563	0.4891	0.5563	0.6250	0.6952	0.1148
35	0.1810	0.2908	0.3527	0.5465	0.4805	0.5465	0.6140	0.6830	0.1128
40	0.1842	0.2858	0.3466	0.5371	0.4722	0.5371	0.6034	0.6712	0.1108
45	0.1873	0.2810	0.3408	0.5280	0.4642	0.5280	0.5932	0.6598	0.1089
50	0.1905	0.2763	0.3351	0.5192	0.4565	0.5192	0.5833	0.6489	0.1071
55	0.1936	0.2718	0.3296	0.5108	0.4491	0.5108	0.5738	0.6383	0.1054
60	0.1968	0.2675	0.3244	0.5026	0.4419	0.5026	0.5646	0.6281	0.1037
65	0.1999	0.2633	0.3193	0.4947	0.4350	0.4947	0.5558	0.6183	0.1021
70	0.2030	0.2592	0.3144	0.4871	0.4283	0.4871	0.5472	0.6087	0.1005
75	0.2062	0.2553	0.3096	0.4797	0.4218	0.4797	0.5390	0.5995	0.0990
80	0.2093	0.2515	0.3050	0.4726	0.4155	0.4726	0.5309	0.5906	0.0975
85	0.2124	0.2478	0.3005	0.4657	0.4094	0.4657	0.5231	0.5819	0.0961
90	0.2155	0.2442	0.2962	0.4589	0.4035	0.4589	0.5156	0.5735	0.0947
95	0.2186	0.2408	0.2920	0.4524	0.3978	0.4524	0.5083	0.5654	0.0934

^a The manufacturer's listing specifies the temperature range for operation.

^b *W/V* [agent weight requirements (kg/m³)] = kilograms of agent required per cubic meter of protected volume to produce indicated concentration at temperature specified.

$$W = \frac{V}{s} \left(\frac{C}{100 - C} \right)$$

^c *t* [temperature (°C)] = The design temperature in the hazard area.

^d *s* [specific volume (m³/kg)] of superheated HCFC-124 vapor can be approximated by the formula:

$$s = 0.1585 + 0.0006t$$

where *t* is the temperature °C.

^e *C* [concentration (%)] = Volumetric concentration of HCFC-124 in air at the temperature indicated.

Table A.5.5.1(g) HFC-125 Total Flooding Quantity (U.S. Units)^a

Temp (<i>t</i>) (°F) ^c	Specific Vapor Volume (<i>s</i>) (ft ³ /lb) ^d	Weight Requirements of Hazard Volume, <i>W/V</i> (lb/ft ³) ^b									
		Design Concentration (% by Volume) ^e									
		7	8	9	10	11	12	13	14	15	16
-50	2.3902	0.0315	0.0364	0.0414	0.0465	0.0517	0.0571	0.0625	0.0681	0.0738	0.0797
-40	2.4577	0.0306	0.0354	0.0402	0.0452	0.0503	0.0555	0.0608	0.0662	0.0718	0.0775
-30	2.5246	0.0298	0.0344	0.0392	0.0440	0.0490	0.0540	0.0592	0.0645	0.0699	0.0754
-20	2.5909	0.0291	0.0336	0.0382	0.0429	0.0477	0.0526	0.0577	0.0628	0.0681	0.0735
-10	2.6568	0.0283	0.0327	0.0372	0.0418	0.0465	0.0513	0.0562	0.0613	0.0664	0.0717
0	2.7222	0.0276	0.0319	0.0363	0.0408	0.0454	0.0501	0.0549	0.0598	0.0648	0.0700
10	2.7872	0.0270	0.0312	0.0355	0.0399	0.0443	0.0489	0.0536	0.0584	0.0633	0.0683
20	2.8518	0.0264	0.0305	0.0347	0.0390	0.0433	0.0478	0.0524	0.0571	0.0619	0.0668
30	2.9162	0.0258	0.0298	0.0339	0.0381	0.0424	0.0468	0.0512	0.0558	0.0605	0.0653
40	2.9803	0.0253	0.0292	0.0332	0.0373	0.0415	0.0458	0.0501	0.0546	0.0592	0.0639
50	3.0441	0.0247	0.0286	0.0325	0.0365	0.0406	0.0448	0.0491	0.0535	0.0580	0.0626
60	3.1077	0.0242	0.0280	0.0318	0.0358	0.0398	0.0439	0.0481	0.0524	0.0568	0.0613
70	3.1712	0.0237	0.0274	0.0312	0.0350	0.0390	0.0430	0.0471	0.0513	0.0556	0.0601
80	3.2344	0.0233	0.0269	0.0306	0.0344	0.0382	0.0422	0.0462	0.0503	0.0546	0.0589
90	3.2975	0.0228	0.0264	0.0300	0.0337	0.0375	0.0414	0.0453	0.0494	0.0535	0.0578
100	3.3605	0.0224	0.0259	0.0294	0.0331	0.0368	0.0406	0.0445	0.0484	0.0525	0.0567
110	3.4233	0.0220	0.0254	0.0289	0.0325	0.0361	0.0398	0.0436	0.0476	0.0515	0.0556
120	3.4859	0.0216	0.0249	0.0284	0.0319	0.0355	0.0391	0.0429	0.0467	0.0506	0.0546
130	3.5485	0.0212	0.0245	0.0279	0.0313	0.0348	0.0384	0.0421	0.0459	0.0497	0.0537
140	3.6110	0.0208	0.0241	0.0274	0.0308	0.0342	0.0378	0.0414	0.0451	0.0489	0.0527
150	3.6734	0.0205	0.0237	0.0269	0.0302	0.0336	0.0371	0.0407	0.0443	0.0480	0.0519
160	3.7357	0.0201	0.0233	0.0265	0.0297	0.0331	0.0365	0.0400	0.0436	0.0472	0.0510
170	3.7979	0.0198	0.0229	0.0260	0.0293	0.0325	0.0359	0.0393	0.0429	0.0465	0.0502
180	3.8600	0.0195	0.0225	0.0256	0.0288	0.0320	0.0353	0.0387	0.0422	0.0457	0.0493
190	3.9221	0.0192	0.0222	0.0252	0.0283	0.0315	0.0348	0.0381	0.0415	0.0450	0.0486
200	3.9841	0.0189	0.0218	0.0248	0.0279	0.0310	0.0342	0.0375	0.0409	0.0443	0.0478

^a The manufacturer's listing specifies the temperature range for operation.

^b *W/V* [agent weight requirements (lb/ft³)] = pounds of agent required per cubic foot of protected volume to produce indicated concentration at temperature specified.

$$W = \frac{V}{s} \left(\frac{C}{100 - C} \right)$$

^c *t* [temperature (°F)] = the design temperature in the hazard area.

^d *s* [specific volume (ft³/lb)] = specific volume of superheated HFC-125 vapor can be approximated by the formula:

$$s = 2.7208 + 0.0064t$$

where *t* = temperature (°F).

^e *C* [concentration (%)] = volumetric concentration of HFC-125 in air at the temperature indicated.



Table A.5.5.1(h) HFC-125 Total Flooding Quantity (SI Units)^a

Temp (<i>t</i>) (°C) ^c	Specific Vapor Volume (<i>s</i>) (m ³ /kg) ^d	Weight Requirements of Hazard Volume, <i>W/V</i> (kg/m ³) ^b									
		Design Concentration (% by Volume) ^e									
		7	8	9	10	11	12	13	14	15	16
-45	0.1496	0.5030	0.5811	0.6609	0.7425	0.8260	0.9113	0.9986	1.0879	1.1793	1.2729
-40	0.1534	0.4906	0.5668	0.6446	0.7242	0.8055	0.8888	0.9739	1.0610	1.1502	1.2415
-35	0.1572	0.4788	0.5532	0.6292	0.7069	0.7863	0.8675	0.9506	1.0356	1.1227	1.2118
-30	0.1609	0.4677	0.5404	0.6146	0.6905	0.7681	0.8474	0.9286	1.0116	1.0966	1.1837
-25	0.1646	0.4572	0.5282	0.6007	0.6749	0.7507	0.8283	0.9076	0.9888	1.0719	1.1570
-20	0.1683	0.4472	0.5166	0.5876	0.6602	0.7343	0.8102	0.8878	0.9672	1.0485	1.1317
-15	0.1720	0.4377	0.5056	0.5751	0.6461	0.7187	0.7930	0.8689	0.9466	1.0262	1.1076
-10	0.1756	0.4286	0.4952	0.5632	0.6327	0.7038	0.7765	0.8509	0.9270	1.0049	1.0847
-5	0.1792	0.4199	0.4851	0.5518	0.6199	0.6896	0.7608	0.8337	0.9082	0.9845	1.0627
0	0.1829	0.4116	0.4756	0.5409	0.6077	0.6759	0.7458	0.8172	0.8903	0.9651	1.0417
5	0.1865	0.4037	0.4664	0.5304	0.5959	0.6629	0.7314	0.8014	0.8731	0.9465	1.0216
10	0.1900	0.3961	0.4576	0.5204	0.5847	0.6504	0.7176	0.7863	0.8566	0.9286	1.0023
15	0.1936	0.3888	0.4491	0.5108	0.5739	0.6384	0.7043	0.7718	0.8408	0.9115	0.9838
20	0.1972	0.3817	0.4410	0.5016	0.5635	0.6268	0.6916	0.7578	0.8256	0.8950	0.9660
25	0.2007	0.3750	0.4332	0.4927	0.5535	0.6157	0.6793	0.7444	0.8110	0.8791	0.9489
30	0.2043	0.3685	0.4257	0.4841	0.5439	0.6050	0.6675	0.7315	0.7969	0.8639	0.9324
35	0.2078	0.3622	0.4184	0.4759	0.5347	0.5947	0.6562	0.7190	0.7833	0.8492	0.9165
40	0.2114	0.3561	0.4114	0.4679	0.5257	0.5848	0.6452	0.7070	0.7702	0.8349	0.9012
45	0.2149	0.3503	0.4047	0.4603	0.5171	0.5752	0.6346	0.6954	0.7576	0.8213	0.8864
50	0.2184	0.3446	0.3982	0.4528	0.5088	0.5659	0.6244	0.6842	0.7454	0.8080	0.8721
55	0.2219	0.3392	0.3918	0.4457	0.5007	0.5569	0.6145	0.6733	0.7336	0.7952	0.8583
60	0.2254	0.3339	0.3857	0.4387	0.4929	0.5483	0.6049	0.6628	0.7221	0.7828	0.8449
65	0.2289	0.3288	0.3798	0.4320	0.4853	0.5399	0.5957	0.6527	0.7111	0.7708	0.8320
70	0.2324	0.3238	0.3741	0.4255	0.4780	0.5318	0.5867	0.6429	0.7004	0.7592	0.8195
75	0.2359	0.3190	0.3686	0.4192	0.4709	0.5239	0.5780	0.6333	0.6900	0.7480	0.8073
80	0.2394	0.3144	0.3632	0.4131	0.4641	0.5162	0.5696	0.6241	0.6799	0.7371	0.7956
85	0.2429	0.3099	0.3580	0.4072	0.4574	0.5088	0.5614	0.6151	0.6702	0.7265	0.7841
90	0.2464	0.3055	0.3529	0.4014	0.4509	0.5016	0.5534	0.6064	0.6607	0.7162	0.7730
95	0.2499	0.3012	0.3480	0.3958	0.4447	0.4946	0.5457	0.5980	0.6515	0.7062	0.7623

^a The manufacturer's listing specifies the temperature range for operation.

^b *W/V* [agent weight requirements (kg/m³)] = kilograms required per cubic meter of protected volume to produce indicated concentration at temperature specified.

$$W = \frac{V}{s} \left(\frac{C}{100 - C} \right)$$

^c *t* [temperature (°C)] = the design temperature in the hazard area.

^d *s* [specific volume (m³/kg)] = specific volume of superheated HFC-125 vapor can be approximated by the formula:

$$s = 0.1826 + 0.0007t$$

where *t* = temperature (°C).

^e *C* [concentration (%)] = volumetric concentration of HFC-125 in air at the temperature indicated.

Table A.5.5.1(i) HFC-227ea Total Flooding Quantity (U.S. Units)^a

Temp (<i>t</i>) (°F) ^c	Specific Vapor Volume (<i>s</i>) (ft ³ /lb) ^d	Weight Requirements of Hazard Volume, <i>W/V</i> (lb/ft ³) ^b									
		Design Concentration (% by Volume) ^e									
		6	7	8	9	10	11	12	13	14	15
10	1.9264	0.0331	0.0391	0.0451	0.0513	0.0570	0.0642	0.0708	0.0776	0.0845	0.0916
20	1.9736	0.0323	0.0381	0.0441	0.0501	0.0563	0.0626	0.0691	0.0757	0.0825	0.0894
30	2.0210	0.0316	0.0372	0.0430	0.0489	0.0550	0.0612	0.0675	0.0739	0.0805	0.0873
40	2.0678	0.0309	0.0364	0.0421	0.0478	0.0537	0.0598	0.0659	0.0723	0.0787	0.0853
50	2.1146	0.0302	0.0356	0.0411	0.0468	0.0525	0.0584	0.0645	0.0707	0.0770	0.0835
60	2.1612	0.0295	0.0348	0.0402	0.0458	0.0514	0.0572	0.0631	0.0691	0.0753	0.0817
70	2.2075	0.0289	0.0341	0.0394	0.0448	0.0503	0.0560	0.0618	0.0677	0.0737	0.0799
80	2.2538	0.0283	0.0334	0.0386	0.0439	0.0493	0.0548	0.0605	0.0663	0.0722	0.0783
90	2.2994	0.0278	0.0327	0.0378	0.0430	0.0483	0.0538	0.0593	0.0650	0.0708	0.0767
100	2.3452	0.0272	0.0321	0.0371	0.0422	0.0474	0.0527	0.0581	0.0637	0.0694	0.0752
110	2.3912	0.0267	0.0315	0.0364	0.0414	0.0465	0.0517	0.0570	0.0625	0.0681	0.0738
120	2.4366	0.0262	0.0309	0.0357	0.0406	0.0456	0.0507	0.0560	0.0613	0.0668	0.0724
130	2.4820	0.0257	0.0303	0.0350	0.0398	0.0448	0.0498	0.0549	0.0602	0.0656	0.0711
140	2.5272	0.0253	0.0298	0.0344	0.0391	0.0440	0.0489	0.0540	0.0591	0.0644	0.0698
150	2.5727	0.0248	0.0293	0.0338	0.0384	0.0432	0.0480	0.0530	0.0581	0.0633	0.0686
160	2.6171	0.0244	0.0288	0.0332	0.0378	0.0425	0.0472	0.0521	0.0571	0.0622	0.0674
170	2.6624	0.0240	0.0283	0.0327	0.0371	0.0417	0.0464	0.0512	0.0561	0.0611	0.0663
180	2.7071	0.0236	0.0278	0.0321	0.0365	0.0410	0.0457	0.0504	0.0552	0.0601	0.0652
190	2.7518	0.0232	0.0274	0.0316	0.0359	0.0404	0.0449	0.0496	0.0543	0.0592	0.0641
200	2.7954	0.0228	0.0269	0.0311	0.0354	0.0397	0.0442	0.0488	0.0535	0.0582	0.0631

^a The manufacturer's listing specifies the temperature range for operation.

^b *W/V* [agent weight requirements (lb/ft³)] = pounds of agent required per cubic foot of protected volume to produce indicated concentration at temperature specified.

$$W = \frac{V}{s} \left(\frac{C}{100 - C} \right)$$

^c *t* [temperature (°F)] = the design temperature in the hazard area.

^d *s* [specific volume (ft³/lb)] = specific volume of superheated HFC-227ea vapor can be approximated by the formula:

$$s = 1.885 + 0.0046t$$

where *t* = temperature (°F).

^e *C* [concentration (%)] = volumetric concentration of HFC-227ea in air at the temperature indicated.



Table A.5.5.1(j) HFC-227ea Total Flooding Quantity (SI Units)^a

Temp(<i>t</i>) (°C) ^c	Specific Vapor Volume(<i>s</i>) (m ³ /kg) ^d	Weight Requirements of Hazard Volume, <i>W/V</i> (kg/m ³) ^b									
		Design Concentration (% per Volume) ^e									
		6	7	8	9	10	11	12	13	14	15
-10	0.1215	0.5254	0.6196	0.7158	0.8142	0.9147	1.0174	1.1225	1.2301	1.3401	1.4527
-5	0.1241	0.5142	0.6064	0.7005	0.7987	0.8951	0.9957	1.0985	1.2038	1.3114	1.4216
0	0.1268	0.5034	0.5936	0.6858	0.7800	0.8763	0.9748	1.0755	1.1785	1.2839	1.3918
5	0.1294	0.4932	0.5816	0.6719	0.7642	0.8586	0.9550	1.0537	1.1546	1.2579	1.3636
10	0.1320	0.4834	0.5700	0.6585	0.7490	0.8414	0.9360	1.0327	1.1316	1.2328	1.3264
15	0.1347	0.4740	0.5589	0.6457	0.7344	0.8251	0.9178	1.0126	1.1096	1.2089	1.3105
20	0.1373	0.4650	0.5483	0.6335	0.7205	0.8094	0.9004	0.9934	1.0886	1.1859	1.2856
25	0.1399	0.4564	0.5382	0.6217	0.7071	0.7944	0.8837	0.9750	1.0684	1.1640	1.2618
30	0.1425	0.4481	0.5284	0.6104	0.6943	0.7800	0.8676	0.9573	1.0490	1.1428	1.2388
35	0.1450	0.4401	0.5190	0.5996	0.6819	0.7661	0.8522	0.9402	1.0303	1.1224	1.2168
40	0.1476	0.4324	0.5099	0.5891	0.6701	0.7528	0.8374	0.9230	1.0124	1.1029	1.1956
45	0.1502	0.4250	0.5012	0.5790	0.6586	0.7399	0.8230	0.9080	0.9950	1.0840	1.1751
50	0.1527	0.4180	0.4929	0.5694	0.6476	0.7276	0.8093	0.8929	0.9784	1.0660	1.1555
55	0.1553	0.4111	0.4847	0.5600	0.6369	0.7156	0.7960	0.8782	0.9623	1.0484	1.1365
60	0.1578	0.4045	0.4770	0.5510	0.6267	0.7041	0.7832	0.8641	0.9469	1.0316	1.1183
65	0.1604	0.3980	0.4694	0.5423	0.6167	0.6929	0.7707	0.8504	0.9318	1.0152	1.1005
70	0.1629	0.3919	0.4621	0.5338	0.6072	0.6821	0.7588	0.8371	0.9173	0.9994	1.0834
75	0.1654	0.3859	0.4550	0.5257	0.5979	0.6717	0.7471	0.8243	0.9033	0.9841	1.0668
80	0.1679	0.3801	0.4482	0.5178	0.5890	0.6617	0.7360	0.8120	0.8898	0.9694	1.0509
85	0.1704	0.3745	0.4416	0.5102	0.5803	0.6519	0.7251	0.8000	0.8767	0.9551	1.0354
90	0.1730	0.3690	0.4351	0.5027	0.5717	0.6423	0.7145	0.7883	0.8638	0.9411	1.0202

^a The manufacturer's listing specifies the temperature range for operation.

^b *W/V* [agent weight requirements (kg/m³)] = kilograms of agent per cubic meter of protected volume to produce indicated concentration at temperature specified.

$$W = \frac{V}{s} \left(\frac{C}{100 - C} \right)$$

^c *t* [temperature (°C)] = the design temperature in the hazard area.

^d *s* [specific volume (m³/kg)] = specific volume of superheated HFC-227ea vapor can be approximated by the formula:

$$s = 0.1269 + 0.0005t$$

where *t* = temperature (°C).

^e *C* [concentration (%)] = volumetric concentration of HFC-227ea in air at the temperature indicated.

Table A.5.5.1(k) HFC-23 Total Flooding Quantity (U.S. Units)^a

Temp (t) (°F) ^c	Specific Vapor Volume (s) (ft ³ /lb) ^d	Weight Requirements of Hazard Volume, W/V (lb/ft ³) ^b									
		Design Concentration (% by Volume) ^e									
		10	12	14	15	16	17	18	19	20	22
-70	3.9636	0.0280	0.0344	0.0411	0.0445	0.0481	0.0517	0.0554	0.0592	0.0631	0.0712
-60	4.0752	0.0273	0.0335	0.0399	0.0433	0.0467	0.0503	0.0539	0.0576	0.0613	0.0692
-50	4.1859	0.0265	0.0326	0.0389	0.0422	0.0455	0.0489	0.0524	0.0560	0.0597	0.0674
-40	4.2959	0.0259	0.0317	0.0379	0.0411	0.0443	0.0477	0.0511	0.0546	0.0582	0.0657
-30	4.4053	0.0252	0.0310	0.0370	0.0401	0.0432	0.0465	0.0498	0.0532	0.0567	0.0640
-20	4.5151	0.0246	0.0302	0.0361	0.0391	0.0422	0.0454	0.0486	0.0520	0.0554	0.0625
-10	4.6225	0.0240	0.0295	0.0352	0.0382	0.0412	0.0443	0.0475	0.0507	0.0541	0.0610
0	4.7305	0.0235	0.0288	0.0344	0.0373	0.0403	0.0433	0.0464	0.0496	0.0528	0.0596
10	4.8383	0.0230	0.0282	0.0336	0.0365	0.0394	0.0423	0.0454	0.0485	0.0517	0.0583
20	4.9457	0.0225	0.0276	0.0329	0.0357	0.0385	0.0414	0.0444	0.0474	0.0505	0.0570
30	5.0529	0.0220	0.0270	0.0322	0.0349	0.0377	0.0405	0.0434	0.0464	0.0495	0.0558
40	5.1599	0.0215	0.0264	0.0315	0.0342	0.0369	0.0397	0.0425	0.0455	0.0485	0.0547
50	5.2666	0.0211	0.0259	0.0309	0.0335	0.0362	0.0389	0.0417	0.0445	0.0475	0.0536
60	5.3733	0.0207	0.0254	0.0303	0.0328	0.0354	0.0381	0.0409	0.0437	0.0465	0.0525
70	5.4797	0.0203	0.0249	0.0297	0.0322	0.0348	0.0374	0.0401	0.0428	0.0456	0.0515
80	5.5860	0.0199	0.0244	0.0291	0.0316	0.0341	0.0367	0.0393	0.0420	0.0448	0.0505
90	5.6922	0.0195	0.0240	0.0286	0.0310	0.0335	0.0360	0.0386	0.0412	0.0439	0.0496
100	5.7983	0.0192	0.0235	0.0281	0.0304	0.0329	0.0353	0.0379	0.0405	0.0431	0.0486
110	5.9043	0.0188	0.0231	0.0276	0.0299	0.0323	0.0347	0.0372	0.0397	0.0423	0.0478
120	6.0102	0.0185	0.0227	0.0271	0.0294	0.0317	0.0341	0.0365	0.0390	0.0416	0.0469
130	6.1160	0.0182	0.0223	0.0266	0.0289	0.0311	0.0335	0.0359	0.0384	0.0409	0.0461
140	6.2217	0.0179	0.0219	0.0262	0.0284	0.0306	0.0329	0.0353	0.0377	0.0402	0.0453
150	6.3274	0.0176	0.0216	0.0257	0.0279	0.0301	0.0324	0.0347	0.0371	0.0395	0.0446
160	6.4330	0.0173	0.0212	0.0253	0.0274	0.0296	0.0318	0.0341	0.0365	0.0389	0.0438
170	6.5385	0.0170	0.0209	0.0249	0.0270	0.0291	0.0313	0.0336	0.0359	0.0382	0.0431
180	6.6440	0.0167	0.0205	0.0245	0.0266	0.0287	0.0308	0.0330	0.0353	0.0376	0.0424
190	6.7494	0.0165	0.0202	0.0241	0.0261	0.0282	0.0303	0.0325	0.0348	0.0370	0.0418

^a The manufacturer's listing specifies the temperature range for operation.

^b W/V [agent weight requirements (lb/ft³)] = pounds of agent required per cubic foot of protected volume to produce indicated concentration at temperature specified.

$$W = \frac{V}{s} \left(\frac{C}{100 - C} \right)$$

^c t [temperature (°F)] = the design temperature in the hazard area.

^d s [specific volume (ft³/lb)] = specific volume of superheated HFC-23 vapor can be approximated by the formula:

$$s = 4.7264 + 0.0107t$$

where t = temperature (°F).

^e C [concentration (%)] = volumetric concentration of HFC-23 in air at the temperature indicated.



Table A.5.5.1(l) HFC-23 Total Flooding Quantity (SI Units)^a

Temp (<i>t</i>) (°C) ^c	Specific Vapor Volume (<i>s</i>) (m ³ /kg) ^d	Weight Requirements of Hazard Volume, <i>W/V</i> (kg/m ³) ^b										
		Design Concentration (% by Volume) ^e										
		10	12	14	15	16	17	18	19	20	22	24
-60	0.2432	0.4568	0.5606	0.6693	0.7255	0.7831	0.8421	0.9025	0.9644	1.0278	1.1596	1.2983
-55	0.2495	0.4453	0.5465	0.6524	0.7072	0.7633	0.8208	0.8797	0.9400	1.0018	1.1303	1.2655
-50	0.2558	0.4344	0.5331	0.6364	0.6899	0.7446	0.8007	0.8581	0.9170	0.9773	1.1026	1.2345
-45	0.2620	0.4241	0.5205	0.6213	0.6735	0.7270	0.7817	0.8378	0.8953	0.9542	1.0765	1.2053
-40	0.2682	0.4143	0.5085	0.6070	0.6580	0.7102	0.7637	0.8185	0.8746	0.9322	1.0517	1.1775
-35	0.2743	0.4050	0.4971	0.5934	0.6433	0.6943	0.7466	0.8002	0.8551	0.9113	1.0281	1.1511
-30	0.2805	0.3962	0.4862	0.5805	0.6292	0.6792	0.7303	0.7827	0.8364	0.8914	1.0057	1.1260
-25	0.2866	0.3878	0.4759	0.5681	0.6158	0.6647	0.7148	0.7661	0.8186	0.8724	0.9843	1.1020
-20	0.2926	0.3797	0.4660	0.5563	0.6031	0.6509	0.6999	0.7502	0.8016	0.8544	0.9639	1.0792
-15	0.2987	0.3720	0.4566	0.5450	0.5908	0.6377	0.6857	0.7349	0.7853	0.8370	0.9443	1.0573
-10	0.3047	0.3646	0.4475	0.5342	0.5791	0.6251	0.6721	0.7203	0.7698	0.8204	0.9256	1.0363
-5	0.3108	0.3575	0.4388	0.5238	0.5679	0.6129	0.6591	0.7064	0.7548	0.8045	0.9076	1.0162
0	0.3168	0.3508	0.4305	0.5139	0.5571	0.6013	0.6466	0.6929	0.7405	0.7892	0.8904	0.9969
5	0.3228	0.3442	0.4225	0.5043	0.5467	0.5901	0.6345	0.6800	0.7267	0.7745	0.8738	0.9783
10	0.3288	0.3379	0.4147	0.4951	0.5367	0.5793	0.6229	0.6676	0.7134	0.7604	0.8578	0.9605
15	0.3348	0.3319	0.4073	0.4863	0.5271	0.5690	0.6118	0.6557	0.7007	0.7468	0.8425	0.9433
20	0.3408	0.3261	0.4002	0.4777	0.5179	0.5590	0.6011	0.6442	0.6884	0.7337	0.8277	0.9267
25	0.3467	0.3204	0.3933	0.4695	0.5089	0.5493	0.5907	0.6331	0.6765	0.7210	0.8134	0.9107
30	0.3527	0.3150	0.3866	0.4616	0.5003	0.5401	0.5807	0.6224	0.6651	0.7088	0.7997	0.8953
35	0.3587	0.3098	0.3802	0.4539	0.4920	0.5311	0.5711	0.6120	0.6540	0.6970	0.7864	0.8804
40	0.3646	0.3047	0.3740	0.4465	0.4840	0.5224	0.5617	0.6020	0.6433	0.6856	0.7735	0.8661
45	0.3706	0.2998	0.3680	0.4393	0.4762	0.5140	0.5527	0.5923	0.6330	0.6746	0.7611	0.8521
50	0.3765	0.2951	0.3622	0.4323	0.4687	0.5059	0.5440	0.5830	0.6230	0.6640	0.7491	0.8387
55	0.3825	0.2905	0.3565	0.4256	0.4614	0.4980	0.5355	0.5739	0.6133	0.6536	0.7374	0.8257
60	0.3884	0.2861	0.3511	0.4191	0.4543	0.4904	0.5273	0.5652	0.6039	0.6436	0.7262	0.8130
65	0.3944	0.2818	0.3458	0.4128	0.4475	0.4830	0.5194	0.5566	0.5948	0.6340	0.7152	0.8008
70	0.4003	0.2776	0.3407	0.4067	0.4409	0.4759	0.5117	0.5484	0.5860	0.6246	0.7046	0.7889

^a The manufacturer's listing specifies the temperature range for operation.

^b W/V [agent weight requirements (kg/m³)] = kilograms required per cubic meter of protected volume to produce indicated concentration at temperature specified.

$$W = \frac{V}{s} \left(\frac{C}{100 - C} \right)$$

^c t [temperature (°C)] = the design temperature in the hazard area.

^d s [specific volume (m³/kg)] = specific volume of superheated HFC-23 vapor can be approximated by the formula:

$$s = 0.3164 + 0.0012t$$

where t = temperature (°C).

^e C [concentration (%)] = volumetric concentration of HFC-23 in air at the temperature indicated.

Table A.5.5.1(m) HFC-236fa Total Flooding Quantity (U.S. Units)^a

Temp (t) (°F) ^c	Specific Vapor Volume (s) (ft ³ /lb) ^d	Weight Requirements of Hazard Volume, W/V (lb/ft ³) ^b									
		Design Concentration (% by Volume) ^e									
		5	6	7	8	9	10	11	12	13	14
30	2.2454	0.0234	0.0284	0.0335	0.0387	0.0440	0.0495	0.0550	0.0607	0.0665	0.0725
40	2.2997	0.0229	0.0278	0.0327	0.0378	0.0430	0.0483	0.0537	0.0593	0.0650	0.0708
50	2.3533	0.0224	0.0271	0.0320	0.0370	0.0420	0.0472	0.0525	0.0579	0.0635	0.0692
60	2.4064	0.0219	0.0265	0.0313	0.0361	0.0411	0.0462	0.0514	0.0567	0.0621	0.0676
70	2.4591	0.0214	0.0260	0.0306	0.0354	0.0402	0.0452	0.0503	0.0555	0.0608	0.0662
80	2.5114	0.0210	0.0254	0.0300	0.0346	0.0394	0.0442	0.0492	0.0543	0.0595	0.0648
90	2.5633	0.0205	0.0249	0.0294	0.0339	0.0386	0.0433	0.0482	0.0532	0.0583	0.0635
100	2.6150	0.0201	0.0244	0.0288	0.0333	0.0378	0.0425	0.0473	0.0521	0.0571	0.0623
110	2.6663	0.0197	0.0239	0.0282	0.0326	0.0371	0.0417	0.0464	0.0511	0.0560	0.0611
120	2.7174	0.0194	0.0235	0.0277	0.0320	0.0364	0.0409	0.0455	0.0502	0.0550	0.0599
130	2.7683	0.0190	0.0231	0.0272	0.0314	0.0357	0.0401	0.0446	0.0493	0.0540	0.0588
140	2.8190	0.0187	0.0226	0.0267	0.0308	0.0351	0.0394	0.0438	0.0484	0.0530	0.0577
150	2.8695	0.0183	0.0222	0.0262	0.0303	0.0345	0.0387	0.0431	0.0475	0.0521	0.0567
160	2.9199	0.0180	0.0219	0.0258	0.0298	0.0339	0.0381	0.0423	0.0467	0.0512	0.0558
170	2.9701	0.0177	0.0215	0.0253	0.0293	0.0333	0.0374	0.0416	0.0459	0.0503	0.0548
180	3.0202	0.0174	0.0211	0.0249	0.0288	0.0327	0.0368	0.0409	0.0452	0.0495	0.0539
190	3.0702	0.0171	0.0208	0.0245	0.0283	0.0322	0.0362	0.0403	0.0444	0.0487	0.0530
200	3.1201	0.0169	0.0205	0.0241	0.0279	0.0317	0.0356	0.0396	0.0437	0.0479	0.0522

^a The manufacturer's listing specifies the temperature range for operation.

^b W/V [agent weight requirements (lb/ft³)] = pounds of agent required per cubic foot of protected volume to produce indicated concentration at temperature specified.

$$W = \frac{V}{s} \left(\frac{C}{100 - C} \right)$$

^c t [temperature (°F)] = the design temperature in the hazard area.

^d s [specific volume (ft³/lb)] = specific volume of superheated HFC-236fa vapor can be approximated by the formula:

$$s = 2.0983 + 0.0051t$$

where t = temperature (°F).

^e C [concentration (%)] = volumetric concentration of HFC-236fa in air at the temperature indicated.



Table A.5.5.1(n) HFC-236fa Total Flooding Quantity (SI Units)^a

Temp (<i>t</i>) (°C)	Specific Vapor Volume (<i>s</i>) (m ³ /kg) ^d	Weight Requirements of Hazard Volume, <i>W/V</i> (kg/m ³) ^b									
		Design Concentration (% by volume) ^c									
		5	6	7	8	9	10	11	12	13	14
0	0.1409	0.3736	0.4531	0.5344	0.6173	0.7021	0.7888	0.8774	0.9681	1.0608	1.1557
5	0.1439	0.3658	0.4436	0.5231	0.6043	0.6873	0.7721	0.8589	0.9476	1.0384	1.1313
10	0.1469	0.3583	0.4345	0.5123	0.5919	0.6732	0.7563	0.8413	0.9282	1.0171	1.1081
15	0.1499	0.3511	0.4258	0.5021	0.5801	0.6598	0.7412	0.8245	0.9097	0.9968	1.0860
20	0.1529	0.3443	0.4176	0.4924	0.5689	0.6470	0.7269	0.8086	0.8921	0.9775	1.0650
25	0.1558	0.3378	0.4097	0.4831	0.5581	0.6348	0.7131	0.7932	0.8752	0.9590	1.0448
30	0.1587	0.3316	0.4021	0.4742	0.5478	0.6231	0.7000	0.7787	0.8591	0.9414	1.0256
35	0.1616	0.3256	0.3949	0.4657	0.5380	0.6119	0.6874	0.7646	0.8436	0.9244	1.0071
40	0.1645	0.3199	0.3880	0.4575	0.5285	0.6011	0.6753	0.7512	0.8288	0.9082	0.9894
45	0.1674	0.3144	0.3813	0.4496	0.5194	0.5908	0.6637	0.7383	0.8145	0.8926	0.9724
50	0.1703	0.3091	0.3749	0.4420	0.5107	0.5808	0.6525	0.7258	0.8008	0.8775	0.9560
55	0.1731	0.3040	0.3687	0.4347	0.5022	0.5712	0.6417	0.7138	0.7876	0.8630	0.9402
60	0.1760	0.2991	0.3627	0.4277	0.4941	0.5620	0.6313	0.7023	0.7748	0.8491	0.9250
65	0.1788	0.2943	0.3569	0.4209	0.4863	0.5531	0.6214	0.6912	0.7626	0.8356	0.9104
70	0.1817	0.2897	0.3514	0.4143	0.4787	0.5444	0.6116	0.6804	0.7507	0.8226	0.8961
75	0.1845	0.2853	0.3460	0.4080	0.4714	0.5361	0.6023	0.6700	0.7392	0.8100	0.8824
80	0.1873	0.2810	0.3408	0.4019	0.4643	0.5280	0.5932	0.6599	0.7280	0.7978	0.8691
85	0.1901	0.2768	0.3358	0.3959	0.4574	0.5202	0.5845	0.6501	0.7173	0.7860	0.8563
90	0.1929	0.2728	0.3309	0.3902	0.4508	0.5127	0.5760	0.6407	0.7069	0.7746	0.8439
95	0.1957	0.2689	0.3261	0.3846	0.4443	0.5053	0.5677	0.6315	0.6968	0.7635	0.8318

^a The manufacturer's listing specifies the temperature range for operation.

^b *W/V* [agent weight requirements (kg/m³)] = kilograms of agent required per cubic meter of protected volume to produce indicated concentration at temperature specified.

$$W = \frac{V}{s} \left(\frac{C}{100 - C} \right)$$

^c *t* [temperature (°C)] = the design temperature in the hazard area.

^d *s* [specific volume (m³/kg)] = specific volume of superheated HFC-236fa vapor can be approximated by the formula:

$$s = 0.1413 + 0.0006t$$

where *t* = temperature (°C).

^e *C* [concentration (%)] = volumetric concentration of HFC-236fa in air at the temperature indicated.

Table A.5.5.1(o) FIC-13II Total Flooding Quantity (U.S. Units)^a

Temp (<i>t</i>) (°F) ^c	Specific Vapor Volume (<i>s</i>) (ft ³ /lb) ^d	Weight Requirements of Hazard Volume, <i>W/V</i> (lb/ft ³) ^b							
		Design Concentration (% by Volume) ^e							
		3	4	5	6	7	8	9	10
0	1.6826	0.0184	0.0248	0.0313	0.0379	0.0447	0.0517	0.0588	0.0660
10	1.7264	0.0179	0.0241	0.0305	0.0370	0.0436	0.0504	0.0573	0.0644
20	1.7703	0.0175	0.0235	0.0297	0.0361	0.0425	0.0491	0.0559	0.0628
30	1.8141	0.0170	0.0230	0.0290	0.0352	0.0415	0.0479	0.0545	0.0612
40	1.8580	0.0166	0.0224	0.0283	0.0344	0.0405	0.0468	0.0532	0.0598
50	1.9019	0.0163	0.0219	0.0277	0.0336	0.0396	0.0457	0.0520	0.0584
60	1.9457	0.0159	0.0214	0.0270	0.0328	0.0387	0.0447	0.0508	0.0571
70	1.9896	0.0155	0.0209	0.0265	0.0321	0.0378	0.0437	0.0497	0.0558
80	2.0335	0.0152	0.0205	0.0259	0.0314	0.0370	0.0428	0.0486	0.0546
90	2.0773	0.0149	0.0201	0.0253	0.0307	0.0362	0.0419	0.0476	0.0535
100	2.1212	0.0146	0.0196	0.0248	0.0301	0.0355	0.0410	0.0466	0.0524
110	2.1650	0.0143	0.0192	0.0243	0.0295	0.0348	0.0402	0.0457	0.0513
120	2.2089	0.0140	0.0189	0.0238	0.0289	0.0341	0.0394	0.0448	0.0503
130	2.2528	0.0137	0.0185	0.0234	0.0283	0.0334	0.0386	0.0439	0.0493
140	2.2966	0.0135	0.0181	0.0229	0.0278	0.0328	0.0379	0.0431	0.0484
150	2.3405	0.0132	0.0178	0.0225	0.0273	0.0322	0.0372	0.0423	0.0475
160	2.3843	0.0130	0.0175	0.0221	0.0268	0.0316	0.0365	0.0415	0.0466
170	2.4282	0.0127	0.0172	0.0217	0.0263	0.0310	0.0358	0.0407	0.0458
180	2.4721	0.0125	0.0169	0.0213	0.0258	0.0304	0.0352	0.0400	0.0449
190	2.5159	0.0123	0.0166	0.0209	0.0254	0.0299	0.0346	0.0393	0.0442
200	2.5598	0.0121	0.0163	0.0206	0.0249	0.0294	0.0340	0.0386	0.0434

^a The manufacturer's listing specifies the temperature range for operation.

^b *W/V* [agent weight requirements (lb/ft³)] = pounds of agent required per cubic foot of protected volume to produce indicated concentration at temperature specified.

$$W = \frac{V}{s} \left(\frac{C}{100 - C} \right)$$

^c *t* [temperature (°F)] = the design temperature in the hazard area.

^d *s* [specific volume (ft³/lb)] = specific volume of superheated FIC-13II vapor can be approximated by the formula:

$$s = 1.683 + 0.0044t$$

where *t* = temperature (°F).

^e *C* [concentration (%)] = volumetric concentration of FIC-13II in air at the temperature indicated.



Table A.5.5.1(p) FIC-131I Total Flooding Quantity (SI Units)^a

Temp (<i>t</i>) (°C) ^c	Specific Vapor Volume (<i>s</i>) (m ³ /kg) ^d	Weight Requirements of Hazard Volume, <i>W/V</i> (kg/m ³) ^b							
		Design Concentration (% by Volume) ^e							
		3	4	5	6	7	8	9	10
-40	0.0938	0.3297	0.4442	0.5611	0.6805	0.8024	0.9270	1.0544	1.1846
-30	0.0988	0.3130	0.4217	0.5327	0.6461	0.7618	0.8801	1.0010	1.1246
-20	0.1038	0.2980	0.4014	0.5070	0.6149	0.7251	0.8377	0.9528	1.0704
-10	0.1088	0.2843	0.3830	0.4837	0.5867	0.6918	0.7992	0.9090	1.0212
0	0.1138	0.2718	0.3661	0.4625	0.5609	0.6614	0.7641	0.8691	0.9764
10	0.1188	0.2603	0.3507	0.4430	0.5373	0.6336	0.7320	0.8325	0.9353
20	0.1238	0.2498	0.3366	0.4251	0.5156	0.6080	0.7024	0.7989	0.8975
30	0.1288	0.2401	0.3235	0.4086	0.4956	0.5844	0.6751	0.7679	0.8627
40	0.1338	0.2311	0.3114	0.3934	0.4771	0.5625	0.6499	0.7392	0.8304
50	0.1388	0.2228	0.3002	0.3792	0.4599	0.5423	0.6265	0.7125	0.8005
60	0.1438	0.2151	0.2898	0.3660	0.4439	0.5234	0.6047	0.6878	0.7727
70	0.1488	0.2078	0.2800	0.3537	0.4290	0.5058	0.5844	0.6647	0.7467
80	0.1538	0.2011	0.2709	0.3422	0.4150	0.4894	0.5654	0.6431	0.7224
90	0.1588	0.1948	0.2624	0.3314	0.4020	0.4740	0.5476	0.6228	0.6997
100	0.1638	0.1888	0.2544	0.3213	0.3897	0.4595	0.5309	0.6038	0.6783

^a The manufacturer's listing specifies the temperature range for operation.

^b *W/V* [agent weight requirements (kg/m³)] = kilograms required per cubic meter of protected volume to produce indicated concentration at temperature specified.

$$W = \frac{V}{s} \left(\frac{C}{100 - C} \right)$$

^c *t* [temperature (°C)] = the design temperature in the hazard area.

^d *s* [specific volume (m³/kg)] = specific volume of superheated FIC-131I vapor can be approximated by the formula:

$$s = 0.1138 + 0.0005t$$

where *t* = temperature (°C).

^e *C* [concentration (%)] = volumetric concentration of FIC-131I in air at the temperature indicated.

Table A.5.5.1(q) HFC Blend B Total Flooding Quantity Table (U.S. Units)^a

Temp (<i>t</i>) (°F) ^c	Specific Vapor Volume (<i>s</i>) (ft ³ /lb) ^d	Weight Requirement of Hazard Volume <i>W/V</i> (lb/ft ³) ^b								
		Concentration (% by volume) ^e								
		8	9	10	11	12	13	14	15	16
-40	2.9642	0.0293	0.0334	0.0375	0.0417	0.0460	0.0504	0.0549	0.0595	0.0643
-30	3.0332	0.0287	0.0326	0.0366	0.0407	0.0450	0.0493	0.0537	0.0582	0.0628
-20	3.1022	0.0280	0.0319	0.0358	0.0398	0.0440	0.0482	0.0525	0.0569	0.0614
-10	3.1712	0.0274	0.0312	0.0350	0.0390	0.0430	0.0471	0.0513	0.0556	0.0601
0	3.2402	0.0268	0.0305	0.0343	0.0381	0.0421	0.0461	0.0502	0.0545	0.0588
10	3.3092	0.0263	0.0299	0.0336	0.0373	0.0412	0.0452	0.0492	0.0533	0.0576
20	3.3782	0.0257	0.0293	0.0329	0.0366	0.0404	0.0442	0.0482	0.0522	0.0564
30	3.4472	0.0252	0.0287	0.0322	0.0359	0.0396	0.0433	0.0472	0.0512	0.0553
40	3.5162	0.0247	0.0281	0.0316	0.0352	0.0388	0.0425	0.0463	0.0502	0.0542
50	3.5852	0.0243	0.0276	0.0310	0.0345	0.0380	0.0417	0.0454	0.0492	0.0531
60	3.6542	0.0238	0.0271	0.0304	0.0338	0.0373	0.0409	0.0445	0.0483	0.0521
70	3.7232	0.0234	0.0266	0.0298	0.0332	0.0366	0.0401	0.0437	0.0474	0.0512
80	3.7922	0.0229	0.0261	0.0293	0.0326	0.0360	0.0394	0.0429	0.0465	0.0502
90	3.8612	0.0225	0.0256	0.0288	0.0320	0.0353	0.0387	0.0422	0.0457	0.0493
100	3.9302	0.0221	0.0252	0.0283	0.0314	0.0347	0.0380	0.0414	0.0449	0.0485
110	3.9992	0.0217	0.0247	0.0278	0.0309	0.0341	0.0374	0.0407	0.0441	0.0476
120	4.0682	0.0214	0.0243	0.0273	0.0304	0.0335	0.0367	0.0400	0.0434	0.0468
130	4.1372	0.0210	0.0239	0.0269	0.0299	0.0330	0.0361	0.0393	0.0427	0.0460
140	4.2062	0.0207	0.0235	0.0264	0.0294	0.0324	0.0355	0.0387	0.0420	0.0453
150	4.2752	0.0203	0.0231	0.0260	0.0289	0.0319	0.0350	0.0381	0.0413	0.0446
160	4.3442	0.0200	0.0228	0.0256	0.0285	0.0314	0.0344	0.0375	0.0406	0.0438
170	4.4132	0.0197	0.0224	0.0252	0.0280	0.0309	0.0339	0.0369	0.0400	0.0432
180	4.4822	0.0194	0.0221	0.0248	0.0276	0.0304	0.0333	0.0363	0.0394	0.0425
190	4.5512	0.0191	0.0217	0.0244	0.0272	0.0300	0.0328	0.0358	0.0388	0.0419
200	4.6202	0.0188	0.0214	0.0240	0.0268	0.0295	0.0323	0.0352	0.0382	0.0412

^aThe manufacturer's listing specifies the temperature range for operation.

^b*W/V* [agent weight requirement (lb/ft³)] = pounds of agent required per cubic foot of protected volume to produce indicated concentration at temperature specified.

$$W = \frac{V}{s} \left(\frac{C}{100 - C} \right)$$

^c *t* [temperature (°F)] = the design temperature in the hazard area.

^d *s* [specific volume (ft³/lb)] = specific volume of superheated HFC Blend B vapor can be approximated by the formula:

$$s = 3.2402 + 0.0069t$$

^e *C* [concentration (%)] = volumetric concentration of HFC Blend B in air at the temperature indicated.



Table A.5.5.1(r) HFC Blend B Total Flooding Quantity Table (SI Units)*

Temp (<i>t</i>) (°C) ^c	Specific Vapor Volume (<i>s</i>) ^d (m ³ /kg)	Weight Requirement of Hazard Volume <i>W/V</i> (kg/m ³) ^b								
		Concentration (% by volume) ^e								
		8	9	10	11	12	13	14	15	16
-40	0.1812	0.4799	0.5458	0.6132	0.6821	0.7526	0.8246	0.8984	0.9739	1.0512
-30	0.1902	0.4572	0.5200	0.5842	0.6498	0.7169	0.7856	0.8559	0.9278	1.0015
-20	0.1992	0.4365	0.4965	0.5578	0.6205	0.6846	0.7501	0.8172	0.8859	0.9562
-10	0.2082	0.4177	0.4750	0.5337	0.5936	0.6550	0.7177	0.7819	0.8476	0.9149
0	0.2172	0.4004	0.4553	0.5116	0.5690	0.6278	0.6880	0.7495	0.8125	0.8770
10	0.2262	0.3844	0.4372	0.4912	0.5464	0.6028	0.6606	0.7197	0.7802	0.8421
20	0.2352	0.3697	0.4205	0.4724	0.5255	0.5798	0.6353	0.6921	0.7503	0.8098
30	0.2442	0.3561	0.4050	0.4550	0.5061	0.5584	0.6119	0.6666	0.7226	0.7800
40	0.2532	0.3434	0.3906	0.4388	0.4881	0.5386	0.5901	0.6429	0.6970	0.7523
50	0.2622	0.3316	0.3772	0.4238	0.4714	0.5201	0.5699	0.6209	0.6730	0.7265
60	0.2712	0.3206	0.3647	0.4097	0.4557	0.5028	0.5510	0.6003	0.6507	0.7023
70	0.2802	0.3103	0.3530	0.3965	0.4411	0.4867	0.5333	0.5810	0.6298	0.6798
80	0.2892	0.3007	0.3420	0.3842	0.4274	0.4715	0.5167	0.5629	0.6102	0.6586
90	0.2982	0.2916	0.3317	0.3726	0.4145	0.4573	0.5011	0.5459	0.5918	0.6388
100	0.3072	0.2831	0.3219	0.3617	0.4023	0.4439	0.4864	0.5299	0.5744	0.6200
110	0.3162	0.2750	0.3128	0.3514	0.3909	0.4313	0.4726	0.5148	0.5581	0.6024
120	0.3252	0.2674	0.3041	0.3417	0.3801	0.4193	0.4595	0.5006	0.5427	0.5857
130	0.3342	0.2602	0.2959	0.3325	0.3698	0.4080	0.4471	0.4871	0.5280	0.5699
140	0.3432	0.2534	0.2882	0.3238	0.3601	0.3973	0.4354	0.4743	0.5142	0.5550
150	0.3522	0.2469	0.2808	0.3155	0.3509	0.3872	0.4243	0.4622	0.5011	0.5408
160	0.3612	0.2407	0.2738	0.3076	0.3422	0.3775	0.4137	0.4507	0.4886	0.5273
170	0.3702	0.2349	0.2672	0.3001	0.3339	0.3684	0.4036	0.4397	0.4767	0.5145
180	0.3792	0.2293	0.2608	0.2930	0.3259	0.3596	0.3941	0.4293	0.4654	0.5023
190	0.3882	0.2240	0.2548	0.2862	0.3184	0.3513	0.3849	0.4193	0.4546	0.4907
200	0.3972	0.2189	0.2490	0.2797	0.3112	0.3433	0.3762	0.4098	0.4443	0.4795

^a The manufacturer's listing specifies the temperature range for operation.

^b *W/V* [agent weight requirement (kg/m³)] = kilograms of agent required per cubic meter of protected volume to produce indicated concentration at temperature specified.

$$W = \frac{V}{s} \left(\frac{C}{100 - C} \right)$$

^c *t* [temperature (°C)] = the design temperature in the hazard area.

^d *s* [specific volume (m³/kg)] = specific volume of superheated Halotron II vapor can be approximated by the formula:

$$s = 0.2172 + 0.0009t$$

^e *C* [concentration (%)] = volumetric concentration of Halotron II in air at the temperature indicated.

A.5.5.2 The volume of inert gas clean agent required to develop a given concentration will be greater than the final volume remaining in the same enclosure. In most cases the inert gas clean agent must be applied in a manner that promotes progressive mixing of the atmosphere. As the clean agent is injected, the displaced atmosphere is exhausted freely from the enclosure through small openings or through special vents. Some inert gas clean agent is therefore lost with the vented atmosphere. This loss becomes greater at high concentrations. This method of application is called “free efflux” flooding.

Under these conditions the volume of inert gas clean agent required to develop a given concentration in the atmosphere is expressed by one of the following equations:

$$e^x = \frac{100}{100 - \% \text{ IG}}$$

or

$$X = 2.303 \text{ Log}_{10} \frac{100}{100 - \% \text{ IG}}$$

where:

% IG = volume percent of inert gas

X = volume of inert gas added per volume of space

Table A.5.5.2(a) through Table A.5.5.2(h) provide the amount of clean agent needed to achieve design concentration.

Table A.5.5.2(a) IG-01 Total Flooding Quantity (U.S. Units)^a

Temp (t) (°F) ^c	Specific Vapor Volume (s) (ft ³ /lb) ^d	Volume Requirements of Agent per Unit Volume of Hazard, $V_{\text{agent}}/V_{\text{enclosure}}$ ^b							
		Design Concentration (% by Volume) ^e							
		34	37	40	42	47	49	58	62
-40	7.67176	0.524	0.583	0.645	0.688	0.801	0.850	1.095	1.221
-30	7.85457	0.512	0.570	0.630	0.672	0.783	0.830	1.069	1.193
-20	8.03738	0.501	0.557	0.615	0.656	0.765	0.811	1.045	1.166
-10	8.22019	0.489	0.544	0.602	0.642	0.748	0.793	1.022	1.140
0	8.40299	0.479	0.532	0.589	0.628	0.732	0.776	1.000	1.115
10	8.58580	0.469	0.521	0.576	0.614	0.716	0.759	0.978	1.091
20	8.76861	0.459	0.510	0.564	0.602	0.701	0.744	0.958	1.088
30	8.95142	0.449	0.500	0.553	0.589	0.687	0.728	0.938	1.047
40	9.13422	0.440	0.490	0.541	0.577	0.673	0.714	0.920	1.026
50	9.31703	0.432	0.480	0.531	0.566	0.660	0.700	0.902	1.006
60	9.49984	0.424	0.471	0.521	0.555	0.647	0.686	0.884	0.986
70	9.68265	0.416	0.462	0.511	0.545	0.635	0.673	0.868	0.958
80	9.86545	0.408	0.453	0.501	0.535	0.623	0.661	0.851	0.950
90	10.04826	0.400	0.445	0.492	0.525	0.612	0.649	0.836	0.932
100	10.23107	0.393	0.437	0.483	0.516	0.601	0.637	0.821	0.916
110	10.41988	0.386	0.430	0.475	0.506	0.590	0.626	0.807	0.900
120	10.59668	0.380	0.422	0.467	0.498	0.580	0.615	0.793	0.884
130	10.77949	0.373	0.415	0.459	0.489	0.570	0.605	0.779	0.869
140	10.96230	0.367	0.408	0.451	0.481	0.561	0.595	0.766	0.855
150	11.14511	0.361	0.401	0.444	0.473	0.552	0.585	0.754	0.841
160	11.32791	0.355	0.395	0.437	0.466	0.543	0.576	0.742	0.827
170	11.51072	0.350	0.389	0.430	0.458	0.534	0.566	0.730	0.814
180	11.69353	0.344	0.383	0.423	0.451	0.526	0.558	0.718	0.801
190	11.87634	0.339	0.377	0.416	0.444	0.518	0.549	0.707	0.789
200	12.05914	0.334	0.371	0.410	0.437	0.510	0.541	0.697	0.777

Note: V_s = the term $X = \ln [100/(100 - C)]$ gives the volume at a rated concentration (%) and temperature to reach an air-agent mixture at the end of flooding time in a volume of 1 ft³.

^a The manufacturer's listing specifies the temperature range for operation.

^b X [agent volume requirements (lb/ft³)] = volume of agent required per cubic foot of protected volume to produce indicated concentration at temperature specified.

$$X = 2.303 \times \left(\frac{V_s}{s} \right) \times \text{Log}_{10} \left(\frac{100}{100 - C} \right) = \left(\frac{V_s}{s} \right) \times \ln \left(\frac{100}{100 - C} \right)$$

^c t [temperature (°F)] = the design temperature in the hazard area.

^d s [specific volume (ft³/lb)] = specific volume of superheated IG-01 vapor can be approximated by the formula:

$$s = 8.514 + 0.0185t$$

where t = temperature (°F).

^e C [concentration (%)] = volumetric concentration of IG-01 in air at the temperature indicated.



Table A.5.5.2(b) IG-01 Total Flooding Quantity (SI Units)^a

Temp (<i>t</i>) (°C) ^c	Specific Vapor Volume (<i>s</i>) (m ³ /kg) ^d	Volume Requirements of Agent per Unit Volume of Hazard, $V_{\text{agent}}/V_{\text{enclosure}}$ ^b							
		Design Concentration (% by Volume) ^e							
		34	37	40	42	47	49	58	62
-20	0.5201	0.4812	0.5350	0.5915	0.6308	0.7352	0.7797	1.0046	1.1205
-10	0.5406	0.4629	0.5147	0.5691	0.6068	0.7073	0.7501	0.9664	1.0779
0	0.5612	0.4459	0.4950	0.5482	0.5846	0.6814	0.7226	0.9310	1.0384
10	0.5817	0.4302	0.4784	0.5289	0.5640	0.6573	0.6971	0.8981	1.0018
15	0.5920	0.4227	0.4701	0.5197	0.5542	0.6459	0.6850	0.8828	0.9844
20	0.6023	0.4155	0.4620	0.5108	0.5447	0.6349	0.6733	0.8675	0.9676
30	0.6228	0.4018	0.4468	0.4940	0.5268	0.6139	0.6511	0.8389	0.9357
35	0.6331	0.3953	0.4395	0.4860	0.5182	0.6040	0.6406	0.8253	0.9205
40	0.6434	0.3890	0.4325	0.4762	0.5099	0.5943	0.6303	0.8121	0.9058
50	0.6639	0.3769	0.4191	0.4634	0.4942	0.5759	0.6108	0.7870	0.8778
60	0.6845	0.3656	0.4066	0.4495	0.4793	0.5587	0.5925	0.7633	0.8514
70	0.7050	0.3550	0.3947	0.4304	0.4654	0.5424	0.5752	0.7411	0.8200
80	0.7256	0.3449	0.3835	0.4240	0.4522	0.5270	0.5589	0.7201	0.8032
90	0.7461	0.3354	0.3730	0.4124	0.4397	0.5125	0.5436	0.7003	0.7811
100	0.7666	0.3264	0.3630	0.4013	0.4270	0.4988	0.5290	0.6815	0.7601
110	0.7872	0.3179	0.3535	0.3908	0.4168	0.4857	0.5152	0.6637	0.7403
120	0.8077	0.3098	0.3445	0.3809	0.4062	0.4734	0.5021	0.6468	0.7215

Note: The term $X = \ln [100/(100 - C)]$ gives the volume at a rated concentration (%) and temperature to reach an air-agent mixture at the end of flooding time in a volume of 1 m³.

^a The manufacturer's listing specifies the temperature range for operation.

^b X [agent volume requirements (kg/m³)] = volume of agent required per cubic meter of protected volume to produce indicated concentration at temperature specified.

$$X = 2.303 \times \left(\frac{V_s}{s} \right) \times \text{Log}_{10} \left(\frac{100}{100 - C} \right) = \left(\frac{V_s}{s} \right) \times \ln \left(\frac{100}{100 - C} \right)$$

^c t [temperature (°C)] = the design temperature in the hazard area.

^d s [specific volume (m³/kg)] = specific volume of superheated IG-01 vapor can be approximated by the formula:

$$s = 0.5685 + 0.00208t$$

where t = temperature (°C).

^e C [concentration (%)] = volumetric concentration of IG-01 in air at the temperature indicated.

Table A.5.5.2(c) IG-100 Total Flooding Quantity (U.S. Units)^a

Temp (<i>t</i>) (°F) ^c	Specific Vapor Volume (<i>s</i>) (ft ³ /lb) ^d	Volume Requirements of Agent per Unit Volume of Hazard, $V_{\text{agent}}/V_{\text{enclosure}}$ ^b							
		Design Concentration (% by Volume) ^e							
		34	37	40	42	47	49	58	62
-40	10.934	0.522	0.581	0.642	0.685	0.798	0.847	1.091	1.216
-30	11.195	0.510	0.567	0.627	0.669	0.780	0.827	1.065	1.188
-20	11.455	0.499	0.554	0.613	0.654	0.762	0.808	1.041	1.161
-10	11.716	0.488	0.542	0.599	0.639	0.745	0.790	1.018	1.135
0	11.976	0.477	0.530	0.586	0.625	0.729	0.773	0.996	1.111
10	12.237	0.467	0.519	0.574	0.612	0.713	0.756	0.975	1.087
20	12.497	0.457	0.508	0.562	0.599	0.698	0.741	0.954	1.064
30	12.758	0.448	0.498	0.550	0.587	0.684	0.726	0.935	1.043
40	13.018	0.439	0.488	0.539	0.575	0.670	0.711	0.916	1.022
50	13.279	0.430	0.478	0.529	0.564	0.657	0.697	0.898	1.002
60	13.540	0.422	0.469	0.519	0.553	0.645	0.684	0.881	0.982
70	13.800	0.414	0.460	0.509	0.543	0.632	0.671	0.864	0.964
80	14.061	0.406	0.452	0.499	0.533	0.621	0.658	0.848	0.946
90	14.321	0.399	0.444	0.490	0.523	0.609	0.646	0.833	0.929
100	14.582	0.392	0.436	0.482	0.514	0.599	0.635	0.818	0.912
110	14.842	0.385	0.428	0.473	0.505	0.588	0.624	0.803	0.896
120	15.103	0.378	0.421	0.465	0.496	0.578	0.613	0.790	0.881
130	15.363	0.372	0.413	0.457	0.487	0.568	0.602	0.776	0.866
140	15.624	0.366	0.407	0.449	0.479	0.559	0.592	0.763	0.851
150	15.885	0.360	0.400	0.442	0.471	0.549	0.583	0.751	0.837
160	16.145	0.354	0.393	0.435	0.464	0.541	0.573	0.739	0.824
170	16.406	0.348	0.387	0.428	0.456	0.532	0.564	0.727	0.811
180	16.666	0.343	0.381	0.421	0.449	0.524	0.555	0.716	0.798
190	16.927	0.337	0.375	0.415	0.442	0.516	0.547	0.705	0.786
200	17.187	0.332	0.370	0.409	0.436	0.508	0.539	0.694	0.774

Note: V_s = the term $X = \ln [100/(100 - C)]$ gives the volume at a rated concentration (%) and temperature to reach an air-agent mixture at the end of flooding time in a volume of 1 ft³.

^a The manufacturer's listing specifies the temperature range for operation.

^b X [agent volume requirements (lb/ft³)] = volume of agent required per cubic foot of protected volume to produce indicated concentration at temperature specified.

$$X = 2.303 \times \left(\frac{V_s}{s} \right) \times \text{Log}_{10} \left(\frac{100}{100 - C} \right) = \left(\frac{V_s}{s} \right) \times \ln \left(\frac{100}{100 - C} \right)$$

^c t [temperature (°F)] = the design temperature in the hazard area.

^d s [specific volume (ft³/lb)] = specific volume of superheated IG-100 vapor can be approximated by the formula:

$$s = 11.976 + 0.02606t$$

where t = temperature (°F).

^e C [concentration (%)] = volumetric concentration of IG-100 in air at the temperature indicated.



Table A.5.5.2(d) IG-100 Total Flooding Quantity (SI Units)^a

Temp (<i>t</i>) (°C) ^c	Specific Vapor Volume (<i>s</i>) (m ³ /kg) ^d	Volume Requirements of Agent per Unit Volume of Hazard, $V_{\text{agent}}/V_{\text{enclosure}}$ ^b							
		Design Concentration (% by Volume) ^e							
		34	37	40	42	47	49	58	62
-40	0.6826	0.5225	0.5809	0.6423	0.6849	0.7983	0.8466	1.0908	1.2166
-30	0.7119	0.5009	0.5570	0.6159	0.6567	0.7654	0.8118	1.0459	1.1665
-20	0.7412	0.4811	0.5350	0.5915	0.6308	0.7352	0.7797	1.0045	1.1204
-10	0.7704	0.4629	0.5147	0.5691	0.6069	0.7073	0.7501	0.9664	1.0779
0	0.7997	0.4459	0.4959	0.5482	0.5846	0.6814	0.7227	0.9310	1.0384
10	0.8290	0.4302	0.4783	0.5289	0.5640	0.6573	0.6971	0.8981	1.0017
20	0.8582	0.4155	0.4621	0.5109	0.5448	0.6349	0.6734	0.8676	0.9677
30	0.8875	0.4018	0.4468	0.4940	0.5268	0.6140	0.6512	0.8389	0.9357
40	0.9168	0.3890	0.4325	0.4782	0.5100	0.5943	0.6304	0.8121	0.9058
50	0.9461	0.3769	0.4191	0.4634	0.4942	0.5759	0.6108	0.7870	0.8778
60	0.9753	0.3657	0.4066	0.4495	0.4794	0.5587	0.5925	0.7634	0.8515
70	1.0046	0.3550	0.3947	0.4364	0.4654	0.5424	0.5753	0.7411	0.8266
80	1.0339	0.3449	0.3835	0.4241	0.4522	0.5270	0.5590	0.7201	0.8032
90	1.0631	0.3355	0.3730	0.4124	0.4398	0.5126	0.5436	0.7004	0.7812
100	1.0924	0.3265	0.3630	0.4013	0.4280	0.4988	0.5290	0.6816	0.7602

Note: The term $X = \ln [100/(100 - C)]$ gives the volume at a rated concentration (%) and temperature to reach an air-agent mixture at the end of flooding time in a volume of 1 m³.

^a The manufacturer's listing specifies the temperature range for operation.

^b X [agent volume requirements (kg/m³)] = volume of agent required per cubic meter of protected volume to produce indicated concentration at temperature specified.

$$X = 2.303 \times \left(\frac{V_s}{s} \right) \times \text{Log}_{10} \left(\frac{100}{100 - C} \right) = \left(\frac{V_s}{s} \right) \times \ln \left(\frac{100}{100 - C} \right)$$

^c t [temperature (°C)] = the design temperature in the hazard area.

^d s [specific volume (m³/kg)] = specific volume of superheated IG-100 vapor can be approximated by the formula:

$$s = 0.7997 + 0.00293t$$

where t = temperature (°C).

^e C [concentration (%)] = volumetric concentration of IG-100 in air at the temperature indicated.

Table A.5.5.2(e) IG-541 Total Flooding Quantity (U.S. Units)^a

Temp (<i>t</i>) (°F) ^c	Specific Vapor Volume (<i>s</i>) (ft ³ /lb) ^d	Volume Requirements of Agent per Unit Volume of Hazard, $V_{\text{agent}}/V_{\text{enclosure}}$ ^b							
		Design Concentration (% by Volume) ^e							
		34	38	42	46	50	54	58	62
-40	9.001	0.524	0.603	0.686	0.802	0.873	0.977	1.096	1.218
-30	9.215	0.513	0.590	0.672	0.760	0.855	0.958	1.070	1.194
-20	9.429	0.501	0.576	0.657	0.743	0.836	0.936	1.046	1.166
-10	9.644	0.490	0.563	0.642	0.726	0.817	0.915	1.022	1.140
0	9.858	0.479	0.551	0.628	0.710	0.799	0.895	1.000	1.116
10	10.072	0.469	0.539	0.615	0.695	0.782	0.876	0.979	1.092
20	10.286	0.459	0.528	0.602	0.681	0.766	0.858	0.958	1.069
30	10.501	0.450	0.517	0.590	0.667	0.750	0.840	0.939	1.047
40	10.715	0.441	0.507	0.578	0.653	0.735	0.824	0.920	1.026
50	10.929	0.432	0.497	0.566	0.641	0.721	0.807	0.902	1.006
60	11.144	0.424	0.487	0.555	0.628	0.707	0.792	0.885	0.987
70	11.358	0.416	0.478	0.545	0.616	0.693	0.777	0.868	0.968
80	11.572	0.408	0.469	0.535	0.605	0.681	0.762	0.852	0.950
90	11.787	0.401	0.461	0.525	0.594	0.668	0.749	0.836	0.933
100	12.001	0.393	0.453	0.516	0.583	0.656	0.735	0.821	0.916
110	12.215	0.386	0.445	0.507	0.573	0.645	0.722	0.807	0.900
120	12.429	0.380	0.437	0.498	0.563	0.634	0.710	0.793	0.884
130	12.644	0.373	0.430	0.489	0.554	0.623	0.698	0.779	0.869
140	12.858	0.367	0.422	0.481	0.544	0.612	0.686	0.766	0.855
150	13.072	0.361	0.415	0.473	0.535	0.602	0.675	0.754	0.841
160	13.287	0.355	0.409	0.466	0.527	0.593	0.664	0.742	0.827
170	13.501	0.350	0.402	0.458	0.518	0.583	0.653	0.730	0.814
180	13.715	0.344	0.396	0.451	0.510	0.574	0.643	0.718	0.801
190	13.930	0.339	0.390	0.444	0.502	0.565	0.633	0.707	0.789
200	14.144	0.334	0.384	0.437	0.495	0.557	0.624	0.697	0.777

Note: V_s = the term $X = \ln [100/(100 - C)]$ gives the volume at a rated concentration (%) and temperature to reach an air-agent mixture at the end of flooding time in a volume of 1 ft³.

^a The manufacturer's listing specifies the temperature range for operation.

^b X [agent volume requirements (lb/ft³) = volume of agent required per cubic foot of protected volume to produce indicated concentration at temperature specified.

$$X = 2.303 \times \left(\frac{V_s}{s} \right) \times \text{Log}_{10} \left(\frac{100}{100 - C} \right) = \left(\frac{V_s}{s} \right) \times \ln \left(\frac{100}{100 - C} \right)$$

^c t [temperature (°F)] = the design temperature in the hazard area.

^d s [specific volume (ft³/lb)] = specific volume of superheated IG-541 vapor can be approximated by the formula:

$$s = 9.8579 + 0.02143t$$

where t = temperature (°F).

^e C [concentration (%)] = volumetric concentration of IG-541 in air at the temperature indicated.



Table A.5.5.2(f) IG-541 Total Flooding Quantity (SI Units)^a

Temp (<i>t</i>) (°C) ^c	Specific Vapor Volume (<i>s</i>) (m ³ /kg) ^d	Volume Requirements of Agent per Unit Volume of Hazard, $V_{\text{agent}}/V_{\text{enclosure}}$ ^b							
		Design Concentration (% by Volume) ^e							
		34	38	42	46	50	54	58	62
-40	0.562	0.524	0.602	0.686	0.776	0.873	0.978	1.093	1.219
-30	0.586	0.502	0.578	0.658	0.745	0.838	0.938	1.048	1.169
-20	0.610	0.482	0.555	0.633	0.716	0.805	0.902	1.007	1.124
-10	0.634	0.464	0.534	0.609	0.689	0.775	0.868	0.969	1.081
0	0.659	0.447	0.515	0.587	0.664	0.746	0.836	0.934	1.042
10	0.683	0.432	0.497	0.566	0.640	0.720	0.807	0.901	1.005
20	0.707	0.417	0.480	0.547	0.619	0.696	0.780	0.871	0.971
30	0.731	0.403	0.464	0.529	0.598	0.673	0.754	0.842	0.940
40	0.755	0.391	0.449	0.512	0.579	0.652	0.730	0.816	0.910
50	0.779	0.379	0.436	0.496	0.562	0.632	0.708	0.791	0.882
60	0.803	0.367	0.423	0.482	0.545	0.613	0.687	0.767	0.855
70	0.827	0.357	0.410	0.468	0.529	0.595	0.667	0.745	0.831
80	0.851	0.347	0.399	0.455	0.514	0.578	0.648	0.724	0.807
90	0.875	0.337	0.388	0.442	0.500	0.563	0.630	0.704	0.785
100	0.900	0.328	0.378	0.430	0.487	0.548	0.613	0.685	0.764

Note: The term $X = \ln [100/(100 - C)]$ gives the volume at a rated concentration (%) and temperature to reach an air-agent mixture at the end of flooding time in a volume of 1 m³.

^a The manufacturer's listing specifies the temperature range for operation.

^b X [agent volume requirements (kg/m³) = volume of agent required per cubic meter of protected volume to produce indicated concentration at temperature specified.

$$X = 2.303 \times \left(\frac{V_s}{s} \right) \times \text{Log}_{10} \left(\frac{100}{100 - C} \right) = \left(\frac{V_s}{s} \right) \times \ln \left(\frac{100}{100 - C} \right)$$

^c t [temperature (°C)] = the design temperature in the hazard area.

^d s [specific volume (m³/kg)] = specific volume of superheated IG-541 vapor can be approximated by the formula:

$$s = 0.65799 + 0.00239t$$

where t = temperature (°C).

^e C [concentration (%)] = volumetric concentration of IG-541 in air at the temperature indicated.

Table A.5.5.2(g) IG-55 Total Flooding Quantity (U.S. Units)^a

Temp (<i>t</i>) (°F) ^c	Specific Vapor Volume (<i>s</i>) (ft ³ /lb) ^d	Volume Requirements of Agent per Unit Volume of Hazard, $V_{\text{agent}}/V_{\text{enclosure}}$ ^b							
		Design Concentration (% by Volume) ^e							
		34	38	42	46	50	54	58	62
-40	9.02108	0.524	0.603	0.688	0.778	0.875	0.980	1.095	1.221
-30	9.23603	0.512	0.589	0.672	0.760	0.854	0.957	1.069	1.193
-20	9.45099	0.501	0.576	0.656	0.742	0.835	0.935	1.045	1.166
-10	9.66594	0.489	0.563	0.642	0.726	0.816	0.915	1.022	1.140
0	9.88090	0.479	0.551	0.628	0.710	0.799	0.895	1.000	1.115
10	10.09586	0.469	0.539	0.614	0.695	0.782	0.876	0.978	1.091
20	10.31081	0.459	0.528	0.602	0.680	0.765	0.857	0.958	1.068
30	10.52577	0.449	0.517	0.589	0.667	0.750	0.840	0.938	1.047
40	10.74073	0.440	0.507	0.577	0.653	0.735	0.823	0.920	1.026
50	10.95568	0.432	0.497	0.566	0.640	0.720	0.807	0.902	1.006
60	11.17064	0.424	0.487	0.555	0.628	0.706	0.791	0.884	0.986
70	11.38560	0.416	0.478	0.545	0.616	0.693	0.777	0.868	0.968
80	11.60055	0.408	0.469	0.535	0.605	0.680	0.762	0.851	0.950
90	11.81551	0.400	0.461	0.525	0.594	0.668	0.748	0.836	0.932
100	12.03046	0.393	0.452	0.516	0.583	0.656	0.735	0.821	0.916
110	12.24542	0.386	0.444	0.506	0.573	0.644	0.722	0.807	0.900
120	12.46038	0.380	0.437	0.498	0.563	0.633	0.710	0.793	0.884
130	12.67533	0.373	0.429	0.489	0.553	0.623	0.698	0.779	0.869
140	12.89029	0.367	0.422	0.481	0.544	0.612	0.686	0.766	0.855
150	13.10525	0.361	0.415	0.473	0.535	0.602	0.675	0.754	0.841
160	13.32020	0.355	0.409	0.466	0.527	0.592	0.664	0.742	0.827
170	13.53516	0.350	0.402	0.458	0.518	0.583	0.653	0.730	0.814
180	13.75012	0.344	0.396	0.451	0.510	0.574	0.643	0.718	0.801
190	13.96507	0.339	0.390	0.444	0.502	0.565	0.633	0.707	0.789
200	14.18003	0.334	0.384	0.437	0.495	0.557	0.623	0.697	0.777

Note: V_s = the term $X = \ln [100/(100 - C)]$ gives the volume at a rated concentration (%) and temperature to reach an air-agent mixture at the end of flooding time in a volume of 1 ft³.

^a The manufacturer's listing specifies the temperature range for operation.

^b X [agent volume requirements (lb/ft³)] = volume of agent required per cubic foot of protected volume to produce indicated concentration at temperature specified.

$$X = 2.303 \times \left(\frac{V_s}{s} \right) \times \text{Log}_{10} \left(\frac{100}{100 - C} \right) = \left(\frac{V_s}{s} \right) \times \ln \left(\frac{100}{100 - C} \right)$$

^c t [temperature (°F)] = the design temperature in the hazard area.

^d s [specific volume (ft³/lb)] = specific volume of superheated IG-55 vapor can be approximated by the formula:

$$s = 9.8809 + 0.0215t$$

where t = temperature (°F).

^e C [concentration (%)] = volumetric concentration of IG-55 in air at the temperature indicated.



Table A.5.5.2(h) IG-55 Total Flooding Quantity (SI Units)^a

Temp (<i>t</i>) (°C) ^c	Specific Vapor Volume (<i>s</i>) (m ³ /kg) ^d	Volume Requirements of Agent per Unit Volume of Hazard, $V_{\text{agent}}/V_{\text{enclosure}}$ ^b							
		Design Concentration (% by Volume) ^e							
		34	38	42	46	50	54	58	62
-40	0.56317	0.524	0.603	0.688	0.778	0.875	0.980	1.095	1.221
-35	0.56324	0.513	0.591	0.673	0.761	0.856	0.959	1.072	1.196
-30	0.58732	0.503	0.579	0.659	0.746	0.839	0.940	1.050	1.171
-25	0.59940	0.493	0.567	0.646	0.731	0.822	0.921	1.029	1.147
-20	0.61148	0.483	0.556	0.633	0.716	0.806	0.903	1.008	1.125
-15	0.62355	0.474	0.545	0.621	0.702	0.790	0.885	0.989	1.103
-10	0.63563	0.465	0.535	0.609	0.689	0.775	0.868	0.970	1.082
-5	0.64771	0.456	0.525	0.598	0.676	0.761	0.852	0.952	1.062
0	0.65979	0.448	0.515	0.587	0.664	0.747	0.837	0.935	1.042
5	0.67186	0.440	0.506	0.576	0.652	0.733	0.822	0.918	1.024
10	0.68394	0.432	0.497	0.566	0.640	0.720	0.807	0.902	1.006
15	0.69602	0.424	0.488	0.556	0.629	0.708	0.793	0.886	0.988
20	0.70810	0.417	0.480	0.547	0.619	0.696	0.779	0.871	0.971
25	0.72017	0.410	0.472	0.538	0.608	0.684	0.766	0.856	0.955
30	0.73225	0.403	0.464	0.529	0.598	0.673	0.754	0.842	0.939
35	0.74433	0.397	0.456	0.520	0.588	0.662	0.742	0.828	0.924
40	0.75641	0.390	0.449	0.512	0.579	0.651	0.730	0.815	0.909
45	0.76848	0.384	0.442	0.504	0.570	0.641	0.718	0.802	0.895
50	0.78056	0.378	0.435	0.496	0.561	0.631	0.707	0.790	0.881
55	0.79264	0.373	0.429	0.488	0.553	0.622	0.696	0.778	0.868
60	0.80471	0.367	0.422	0.481	0.544	0.612	0.686	0.766	0.855
65	0.81679	0.362	0.416	0.474	0.536	0.603	0.676	0.755	0.842
70	0.82887	0.356	0.410	0.467	0.528	0.594	0.666	0.744	0.830
75	0.84095	0.351	0.404	0.460	0.521	0.586	0.656	0.733	0.818
80	0.85302	0.346	0.398	0.454	0.513	0.578	0.647	0.723	0.806
85	0.86510	0.341	0.393	0.448	0.506	0.569	0.638	0.713	0.795
90	0.87718	0.337	0.387	0.441	0.499	0.562	0.629	0.703	0.784
95	0.88926	0.332	0.382	0.435	0.493	0.554	0.621	0.693	0.773
100	0.90133	0.328	0.377	0.430	0.486	0.547	0.612	0.684	0.763

Note: The term $X = \ln [100/(100 - C)]$ gives the volume at a rated concentration (%) and temperature to reach an air-agent mixture at the end of flooding time in a volume of 1 m³.

^a The manufacturer's listing specifies the temperature range for operation.

^b X [agent volume requirements (kg/m³) = volume of agent required per cubic meter of protected volume to produce indicated concentration at temperature specified.

$$X = 2.303 \times \left(\frac{V_s}{s} \right) \times \text{Log}_{10} \left(\frac{100}{100 - C} \right) = \left(\frac{V_s}{s} \right) \times \ln \left(\frac{100}{100 - C} \right)$$

^c t [temperature (°C)] = the design temperature in the hazard area.

^d s [specific volume (m³/kg)] = specific volume of superheated IG-55 vapor can be approximated by the formula:

$$s = 0.6598 + 0.00242t$$

where t = temperature (°C).

^e C [concentration (%)] = volumetric concentration of IG-55 in air at the temperature indicated.

A.5.5.3 The minimum design concentration based on the cup burner extinguishing concentration plus 30 percent or Class A fire test extinguishing concentration plus 20 percent should encompass design tolerances for most applications. However, these safety factors do not account for specific conditions or requirements for some particular applications that can require additional agent to ensure complete fire extinguishment. The following list gives certain conditions or considerations that can require the use of design factors that would increase the amount of agent used.

- (1) *Unclosable openings* (see also 5.7.2). Special considerations should be taken into account when designing a fire suppression system for an enclosure that cannot or will not be sealed or closed before the fire suppression system is discharged. The loss of agent through the openings needs to be compensated for by some method. Compensation for unclosable openings can be handled through extending the discharge time, which in turn extends the period of agent application. A method of determining the additional agent required/rate of application can be accomplished by conducting an enclosure integrity test per Annex C. When applying agent to compensate for the loss through an unclosable opening, consideration needs to be taken to extend the discharge of agent to enable the concentration within the enclosure to be held for a longer period of time. The discharge time defined in 5.7.1.2.1 is for the time required for the initial agent required to protect the enclosure without leakage through the unclosable openings. Without extending the discharge time for the additional agent being applied, leak rates through the unclosable openings will increase.
- (2) *Acid gas formation considerations*. High concentrations of hydrogen fluoride (HF) can be expected at cup burner design concentrations. HF can be reduced by increasing the design concentration. Dramatic reduction can be achieved by increasing design concentration up to cup burner plus 30 percent. Above cup burner plus 30 percent, reduction in HF is not as dramatic. (For further information see Sheinson et al., 1994, and Sheinson et al., 1995.)
- (3) *Fuel geometry considerations*. For Class A and B fires, fuel geometry and compartment obstructions can affect agent concentration at the fire. Full-scale machinery space tests conducted by the Naval Research Laboratory (NRL) have shown that for a large [850 m³ (30,000 ft³)] enclosure with a complex obstructed fuel geometry, agent concentration can vary ± 20 percent. Increasing the design concentration or adding or relocating discharge nozzles can compensate for concentrations below the design concentration. For further information see the Naval Research Laboratory report.
- (4) *Enclosure geometry*. Typically in applications involving unusual enclosure geometries, agent distribution is addressed through nozzle placement. If the geometry of the enclosure (or system design) is such that the agent distribution cannot be adequately addressed through nozzle placement, additional concentration should be considered. An example of such applications could be enclosures having very high or low aspect ratios (length/width).
- (5) *Obstructions within the enclosure*. The following three considerations should be given to enclosure obstructions:
 - (a) Room volume should be calculated considering the room empty. Exceptions can only be made for structural components or shafts that pass through the room.

- (b) For small room volumes, consideration should be given to equipment/storage that take up a considerable percentage of the room volume. Specifically, consider if the reduced volume will raise the effective concentration of the agent from the NOAEL to the LOAEL in normally occupied spaces. However, this consideration must be closely balanced against the need to maintain an adequate concentration even when the room is empty.
- (c) Obstructions located near the nozzle could block or impede agent discharge from the nozzle and could affect the distribution of the agent within the enclosure. Obstructions such as ducts, cable, trays, large conduits, and light fixtures have the potential to disrupt the flow pattern of the agent from the nozzle. If the flow of the agent is forced down to the floor, for example, it is unlikely that concentration will be achieved at the mid or upper elevations. Certainly uniform dispersion and concentration will not be achieved.

A.5.5.3.1 This design factor is meant to compensate for the uncertainty in the quantity of agent flowing through a pipe as the agent passes through an increasing number of tees. The listing tests generally incorporate systems with a very limited number of tees (2 to 4). If the number of tees in a system is greater than this, additional agent is required to compensate for the uncertainty at the tee splits and ensure that a sufficient quantity of agent is delivered to each hazard. Tees that deliver agent only to nozzles within a hazard are not counted for this design factor because it is believed mixing within the hazard will compensate for any discrepancy.

The design factor for the inert gases is less than the halocarbons because it is believed that the flow of inert gases can be more accurately predicted and inert gases are less sensitive to pipe variability.

The following two examples illustrate the method for determining the design factor tee count. These examples might not represent good design practice.

(1) *Example 1.*

Hazard	Design Factor Tee Count
	[See Figure A.5.5.3.1(a)]
1	9 (tees A, B, C, D, E, F, G, H, I)
2	8 (tees C, D, E, F, G, H, I, A)
3	1 (tee C)

Therefore, if the system uses a halocarbon agent, the design factor is 0.05, and if the system uses an inert gas agent, the design factor is 0.01.

(2) *Example 2.*

Hazard	Design Factor Tee Count
	[See Figure A.5.5.3.1(b).]
1	5 (tees B, C, D, E, F)
2	3 (tees B, E, H)
3	2 (tees E, F)

For Hazard 1, the branch consisting of tees H, I, and J, F is not used because the other branch has a greater tee count.

Therefore, if the system uses a halocarbon agent, the design factor is 0.01, and if the system uses an inert gas agent, the design factor would be 0.00.



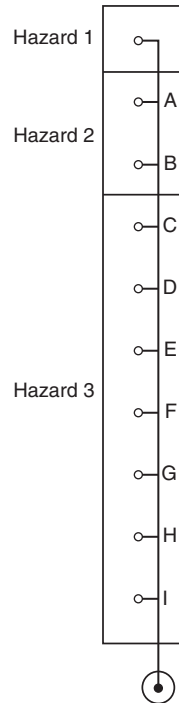

FIGURE A.5.5.3.1(a) Piping for Design Factor Tee Count for Example 1.

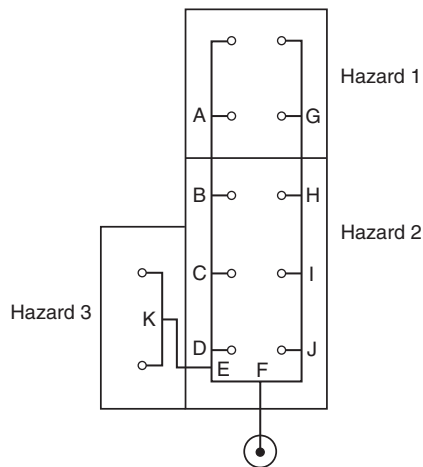

FIGURE A.5.5.3.1(b) Piping for Design Factor Tee Count for Example 2.

A.5.5.3.2 The listing of engineered halon alternative systems requires running a number of tests that include measuring the agent quantity from each nozzle. To successfully pass these tests, the flow calculation software cannot overpredict the measured mass by more than 5 percent nor underpredict the measured mass by more than 10 percent. Experience performing these tests indicates the maximum laboratory accuracy for the calculations is ± 5 percent of the measured value with a 90 percent certainty. This means that 90 percent of the measured agent quantities will be within ± 5 percent of the predicted value. If the error is due to random factors, then this can be represented statistically

by a normal (Gaussian) distribution. A normal distribution curve is shown in Figure A.5.5.3.2(a), with the measured mass normalized by the predicted value. The resulting standard deviation is 0.0304 from standard tables. These systems generally have 2 tees and 3 nozzles.

For a system that utilizes more than 2 tees, the error will propagate and the certainty for the prediction of the agent quantity will be less. The more tees between a nozzle and the cylinder, the lower the certainty. This propagation of error can be calculated and results in a new normal distribution with a greater standard deviation. This can be calculated for any number of tees. For example, the standard deviation for a system with 8 tees would be 0.0608.

For the purpose of this standard, the uncertainty for the prediction for an installed system is limited to having at least 99 percent of the nozzles deliver at least 90 percent of the predicted agent quantity. This implies not “using up” more than one half of the 20 percent safety factor for 99 percent of the nozzles. For a normal distribution with a standard deviation of 0.0608, the tail area representing 1 percent of the systems occurs at a normalized mass value of 0.859.

It is apparent that significantly more than 1 percent of the systems will have less than 90 percent of the predicted mass delivered. To rectify this situation, more agent should be used in the system, which would move the entire probability curve up. The quantity of agent that would need to be added is as follows:

$$0.90 - 0.859 = 0.041 \quad \text{or} \quad 4.1 \text{ percent}$$

The addition of 4.1 percent more agent would ensure that 99 percent of the nozzles deliver at least 90 percent of the required mass of agent.

The analysis for Table A.5.5.3.2 was performed for up to 19 tees, 20 nozzles, in a system. [See Figure A.5.5.3.2(b) through Figure A.5.5.3.2(g).]

A.5.5.3.3 Some areas affected by pressures other than sea level include hyperbaric enclosures, facilities where ventilation fans are used to create artificially higher or lower pressures such as test chambers, and facilities at altitudes above or below sea level. Although mines are usually below normal ground levels, they occasionally have to be ventilated so that personnel can work in that environment. Ambient pressures in that situation can be considerably different from those expected by a pure altitude correction.

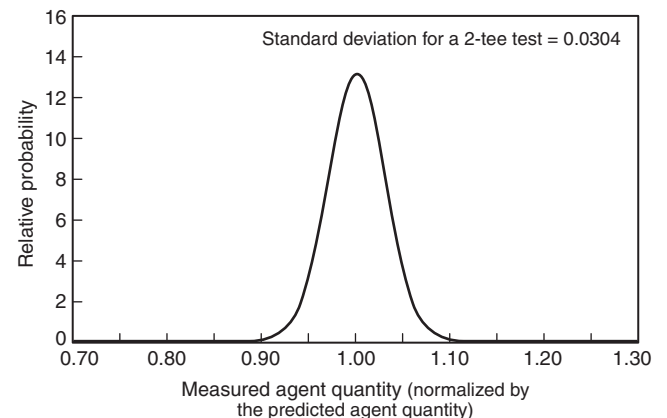

FIGURE A.5.5.3.2(a) Normal Distribution Curve.

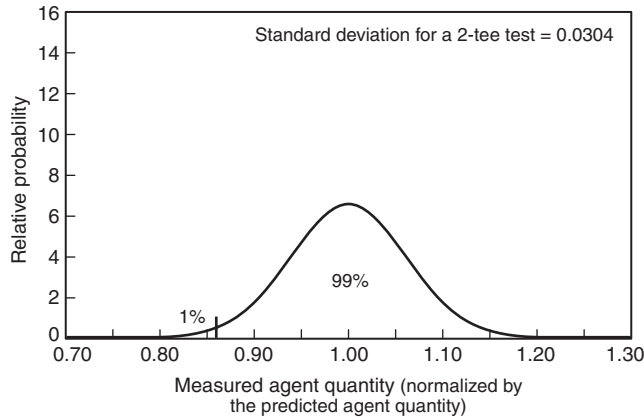

FIGURE A.5.5.3.2(b) Distribution Curve No. 1.

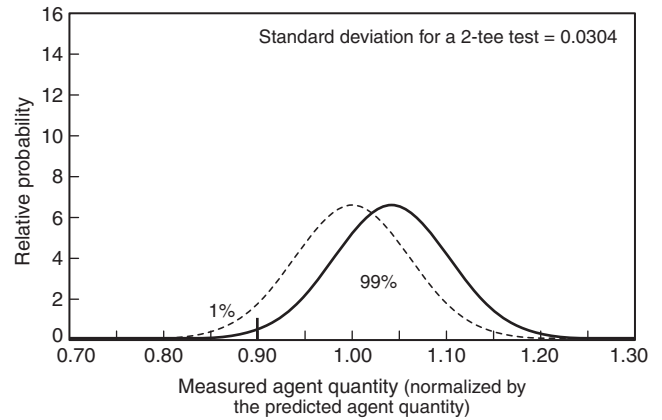

FIGURE A.5.5.3.2(d) Distribution Curve No. 3.

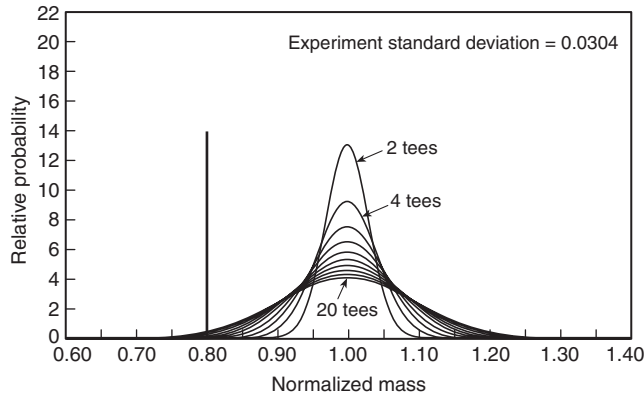

FIGURE A.5.5.3.2(c) Distribution Curve No. 2.

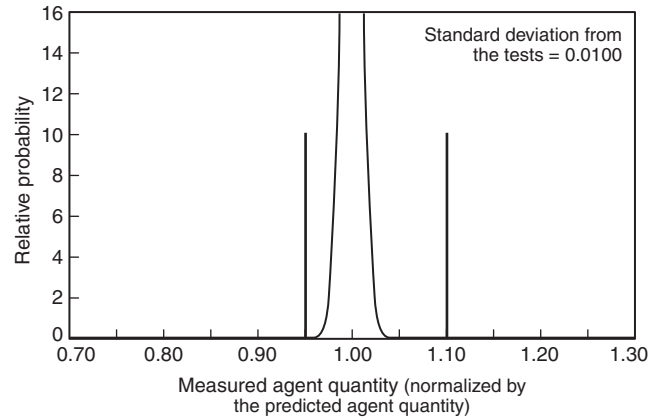

FIGURE A.5.5.3.2(e) Distribution Curve No. 4.

Table A.5.5.3.2 Plastic Fuel Properties

Fuel	Description	Source	Density (g/cm ³)	Ignition Time at 25 kW/m ² Irradiance (sec)	180 Second Average Heat Release Rate at 25 kW/m ² Irradiance (sec)
PMMA	Polycast acrylic sheet	Polycast Technology Corporation	1.190	77 (±10%)	304 (±10%)
PP	Polypropylene homopolymer/Poly Hi solidur	Menasha Corporation	0.905	91 (±10%)	200 (±10%)
ABS	Absylux	Westlake Plastics Company	1.040	115 (±10%)	425 (±10%)

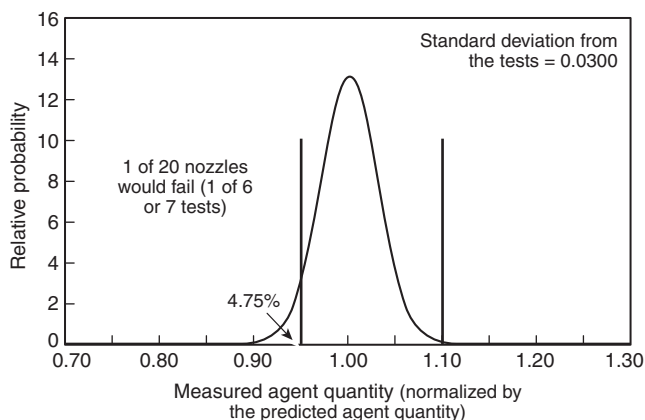

FIGURE A.5.5.3.2(f) Distribution Curve No. 5.

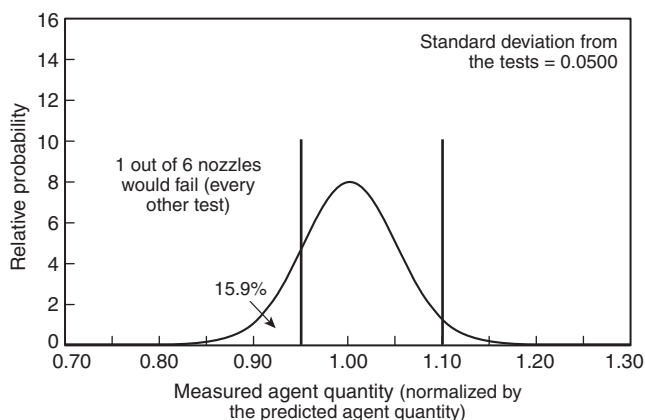

FIGURE A.5.5.3.2(g) Distribution Curve No. 6.

Although adjustments are required for barometric pressures equivalent to 3000 ft (915 m) or more above or below sea level, adjustments can be made for any ambient pressure condition.

The atmospheric correction factor is not linear. However, in the moderate range discussed it can be closely approximated with two lines:

For –3000 ft to 5500 ft of equivalent altitude:

$$Y = (-0.000036 \times X) + 1$$

For 5501 ft to 10,000 ft of equivalent altitude:

$$Y = (-0.00003 \times X) + 0.96$$

where:

Y = correction factor

X = altitude (ft)

For SI units, 1 ft = 0.305 m.

The increase, from the 1996 edition to this edition, in safety factor for manually actuated systems and systems protecting Class B hazards, is intended to account for the uncertainty in minimum design concentration associated with these types of systems and hazards.

The presence of hot metal surfaces, large fire sizes, increased fuel temperatures, and other variables associated with longer pre-burn times may increase the minimum extinguishing concentration needed for these types of fires. In addition, the increased safety factor will serve to reduce decomposition product formation for halocarbon agents in the presence of larger fires expected in manually operated systems and Class B hazards.

There have been no reported system failures associated with these types of fires in fueled installations, and successful extinguishment events have been reported for systems designed and installed in accordance with previous editions of this standard.

This change is intended to enhance the overall effectiveness of new clean agent systems and is based on theoretical and laboratory experience. This change in safety factor does not apply to existing systems. Field experience indicates that any existing system designed with a 20 percent safety factor will perform as intended.

The ambient pressure is affected by changes in altitude, pressurization or depressurization of the protected enclosure, and weather-related barometric pressure changes. The design factor to account for cases where the pressure of the protected hazard is different from atmospheric pressure is computed as the ratio of the nominal absolute pressure within the hazard divided by the average atmospheric pressure at sea level [14.7 psia/(1 bar)].

A.5.6 In establishing the hold time, designers and authorities having jurisdiction should consider the following or other unique factors that can influence the performance of the suppression system:

- (1) Response time of trained personnel
- (2) Sources of persistent ignition
- (3) Excessive enclosure leakage
- (4) System enclosure venting requirements
- (5) Inertion and reflash hazards
- (6) Wind down of rotating equipment

The hold time for the duration of protection should be sufficient to control the initial event and allow for support should resurgence occur once the agent has dissipated.

Energized electrical equipment that could provide a prolonged ignition source should be de-energized prior to or during agent discharge.

If electrical equipment cannot be de-energized, consideration should be given to the use of extended-agent discharge, higher initial concentration, and the possibility of the formation of combustion and decomposition products. Additional testing can be needed on suppression of energized electrical equipment fires to determine these quantities.

Examples of methods developed to simulate overcurrents and heating along an electrical conductor are contained in several reports. The first two tests are included in reports by Hughes Associates Inc., Baltimore MD; and Western Fire Center, Kelso, WA.

The first test, designed to replicate an overcurrent event, is called the Ohmic Heating Test. In this test, a length of power cable was overloaded electrically by connection to an arc welder, resulting in internal overheating of the cable that leads to pyrolysis of the insulation material. A small pilot flame was applied to the sample after the conductors were heated and smoke was issuing from the center of the cable. A short pre-burn was allowed to reach a fully developed fire, and then the clean agent was discharged. Current was applied through-

out the discharge, and continued for approximately 10 minutes following discharge to check for reflash (none was observed). The results of tests using HFC-227ea as the extinguishing agent are reported in Table A.5.6(a). The results of tests using FK-5-1-12 as the extinguishing agent are reported in Table A.5.6(b).

In the second test method, called the Conductive Heating Test, the lower 4 in. (101 mm) of a 10.25 in. (260 mm) long sample of 350 mcm diameter power cable was clamped vertically inside a ring heater, ensuring firm contact between the inside of the heater and the copper conductor. The heater was set to 890°C, and the sample was heated until the temperature at the top of the sample reached 310°C. The sample was then ignited by a small pilot flame, and the ensuing fire was allowed to fully develop before agent discharge. The heater was energized throughout the discharge and for 10 minutes thereafter to check for reflash (none was observed), cable was de-energized without ignition. The results of tests using HFC-227ea as the extinguishing agent are reported in Table A.5.6(c). The results of tests using FK-5-1-12 as the extinguishing agent are reported in Table A.5.6(d). The third test reported by SEVO Systems replicates the conductive heating test with the cable energized and providing the ignition source via an electric arc. The fourth test report is included in a report by Modular Protection Group, Lenexa, KS, which is an update on the evaluation of selected agents for suppression Class C energized fires.

The objective of the tests conducted by Modular Protection Corporation was to investigate the effectiveness of new clean agents to extinguish Class C energized fires of polymeric materials ignited by heat flux. Specific tests were conducted to determine the minimum agent concentration required to extinguish Class C energized fires and the minimum agent concentration required to prevent reflash/re-ignition.

The clean agents selected for testing were FC-2-1-8 (3M), HFC-23 (DuPont), HFC-227ea (Great Lakes), and HFC-236fa (DuPont).

The criteria used for conducting tests on these clean agents were as follows:

Pre-burn	60 seconds
Discharge time	≤10 seconds
Flame extinguishment	<30 seconds
No reflash/re-ignition	≥10 seconds

Each clean agent was tested for minimum concentration required for flame extinguishment and minimum concentration required to prevent reflash/re-ignition for a period up to 10 minutes after flame extinguishment. The test protocol used to conduct each of the clean agent tests is displayed in Table A.5.6(e).

The results of the clean agent tests to determine minimum concentrations required to extinguish and to prevent reflash/re-ignition at energy levels of 48 W and 192 W are displayed in Table A.5.6(f).

Table A.5.6(a) Ohmic Heating Suppression Test Results for HFC-227ea

Sample	Current (A)	Number of Tests	HFC-227ea Concentration (%)	Extinguishment ^a
8 AWG, cross-linked polyethylene, arranged in a horizontal bundle of 5 cables with only the center cable powered	350	4	5.8	Yes
		1	5.0	Yes
8 AWG, cross-linked polyethylene cable, arranged in a vertical bundle of 5 cables with only the center cable powered	350	4	5.8	Yes
		1	5.0	Yes
12 AWG, SJTW-A, 3 conductors per cable, arranged in a horizontal bundle of 6 cables with 4 of the 18 conductors powered	150	3	5.8	Yes
		2	5.5	Yes
		1	5.0	Yes
8 AWG, PVC cable, arranged in a horizontal bundle of 7 cables with the center cable powered	325	3	5.8	Yes
18 AWG, 3 conductors per cable, polyethylene insulation on conductors, with chrome PVC jacket around twisted conductors, 4 cable horizontal bundle, with 12 conductors powered	29	4	5.8	Yes ^b
16 AWG, 12 conductors per cable, neoprene over rubber insulation, single horizontal cable, 9 conductors powered	56	3	5.8	Yes
18 AWG, polyethylene insulated coaxial cable with the outer jacket and braided conductor removed (i.e., center core of the coaxial cable only), arranged in a horizontal bundle of 4 cables, all 4 conductors powered ^c	119	1	5.7	No
		1	5.8	No
		2	6.5	No
		4	6.8	Yes
		3	7.2	Yes

^aIn all cases where the fire was extinguished, the time to extinguishment from beginning of agent discharge was between 3 and 15 seconds.

^bIn one test the gas did not completely extinguish the fire.

^cIn this series, the polyethylene insulation melted and formed a pool fire. A tray was installed under the wire bundle so that the glowing wires were in contact with the molten pool of polyethylene.



Table A.5.6(b) Ohmic Heating Suppression Test Results for FK-5-1-12

Sample	Current (A)	Number of Tests	FK-5-1-12 Concentration (%) ^a	Extinguishment ^b
8 AWG, cross-linked polyethylene, arranged in a horizontal bundle of 5 cables with only the center cable powered	350	5	3.5	Yes ^c
8 AWG, cross-linked polyethylene cable, arranged in a vertical bundle of 5 cables with only the center cable powered	350	4	4.2	Yes
12 AWG, SJTW-A, 3 conductors per cable, arranged in a horizontal bundle of 6 cables with 4 of the 18 conductors powered	150			
8 AWG, PVC cable, arranged in a horizontal bundle of 7 cables with the center cable powered	325			
18 AWG, 3 conductors per cable, polyethylene insulation on conductors, with chrome PVC jacket around twisted conductors, 4 cable horizontal bundle, with 12 conductors powered	29	4	3.5	Yes
16 AWG, 12 conductors per cable, neoprene over rubber insulation, single horizontal cable, 9 conductors powered	56	4	4.2	Yes
18 AWG, polyethylene insulated coaxial cable with the outer jacket and braided conductor removed (i.e., center core of the coaxial cable only), arranged in a horizontal bundle of 4 cables, all 4 conductors powered ^c	119			

^aConcentrations based on Ideal Gas Law calculations.

^bIn three tests the agent did not completely extinguish the fire.

^cIn all cases where the fire was extinguished, the time to extinguishment from beginning of agent discharge was between 9 and 20 seconds.

Table A.5.6(c) Conductive Heating Suppression Test Results for HFC-227ea

Sample	Number of Tests	HFC-227ea Concentration (%)	Extinguishment	Average Time to Extinguishment (sec)
350 mcm copper cable, Hypalon insulation with cotton braid sheathing and saturant (Lucent KS-5482L)	1	5.2	Yes	20
	2	5.8		11
	1	5.9		7
	2	6.0		10
350 mcm copper cable, Hypalon insulation (Lucent KS-20921)	3	5.8	Yes	9
	1	5.9		11
	1	6.0		10

Table A.5.6(d) Conductive Heating Suppression Test Results for FK-5-1-12

Sample	Number of Tests	FK-5-1-12 Concentration (%) [*]	Extinguishment	Average Time to Extinguishment (sec)
350 mcm copper cable, Hypalon insulation with cotton braid sheathing and saturant (Lucent KS-5482L)	2	3.5	Yes	15
350 mcm copper cable, Hypalon insulation (Lucent KS-20921)	2	3.5	Yes	17

^{*}Concentration based on Ideal Gas Law calculations.

Table A.5.6(e) Test Protocol

Test Protocol	Fuel Sample/Wire Configuration	Energy Level (W)	Agent	Tests Conducted			
1	4 in. long, 24 gauge, Nichrome wire inserted in center of PMMA block (3 in. x 1 in. x 3/8 in.)	48	FK-5-1-12	2			
			HFC-125	12			
			HFC-23	7			
			HFC-227ea	7			
			HFC-236fa	26			
			IG-541	9			
			2	12 in. long, 20 gauge, Nichrome wire wrapped around PMMA block (3 in. x 2 in. x 1/4 in.)	192	FK-5-1-12	7
						HFC-125	8
						HFC-23	5
HFC-227ea	7						
HFC-236fa	8						
IG-541	9						

References:

1. Niemann, R., Bayless, H., and Craft, C., "Evaluation of Selected NFPA 2001 Agents for Suppressing Class 'C' Energized Fires." *Proceedings*, Halon Options Technical Working Conference, Albuquerque, NM, pp. 399-412, 1996.
2. Driscoll, M., Rivers, P., 3M, "Clean Extinguishing Agents and Continuously Energized Circuits: Recent Findings," *Proceedings*, Halon Options Technical Working Conference, Albuquerque, NM, pp. 129-140, 1997.
3. Bayless, H., and Niemann, R., "Update on the Evaluation of Selected NFPA 2001 Agents for Suppressing Class 'C' Energized Fires," *Proceedings*, Halon Options Technical Working Conference, Albuquerque, NM, pp. 293-294, 1998.
4. Bengtson, G., Niemann, R., "Update in the Evaluation of Selected NFPA 2001 Agents for Suppressing Class C Energized Fires," *Proceedings*, Halon Options Technical Working Conference, Albuquerque, NM, May 24-26, 2005.

A.5.7.1.2 The optimum discharge time is a function of many variables. The following five variables are very important:

- (1) Limitation of decomposition products
- (2) Limitation of fire damage and its effects
- (3) Enhanced agent mixing
- (4) Limitation of compartment overpressure
- (5) Secondary nozzle effects

It is essential for the end user to understand that both the products of combustion and decomposition products formed from the suppression agent contribute to the total threat to life or assets associated with a fire.

Essentially all fires will produce carbon monoxide and carbon dioxide, and the contribution of these products to the toxic threat posed by the fire event is well known. In the case of large fires, the high temperatures encountered can by themselves lead to life- and asset-threatening conditions. In addition, most fires produce smoke, and it is well documented that damage to sensitive assets can occur at very low levels of smoke. Depending upon the particular fuel involved, numerous toxic products of combustion can be produced in a fire (e.g., HCl, HBr, HF, HCN, CO).

The halogenated hydrocarbon fire extinguishing agents described in this standard will break down into their decom-

Table A.5.6(f) Test Results

Agent	Energy Level (W)	Extinguish Concentration, Percent by Volume	Prevent Reflash/Reignition Concentration, Minimum Percent by Volume
FK-5-1-12	48	4.1	4.5
	192	4.5	5.1
HFC-125	48	11.5	12.0
	192	11.9	12.4
HFC-23	48	13.0	16.0
	192	14.0	20.0
HFC-227ea	48	6.5	8.0
	192	8.0	9.0
HFC-236fa	48	6.3	6.5
	192	6.5	9.0
IG-541	48	41.8	49.0
	192	49.0	56.1

References:

1. Niemann, R., Bayless, H., and Craft, C., "Evaluation of Selected NFPA 2001 Agents for Suppressing Class 'C' Energized Fires," *Proceedings*, Halon Options Technical Working Conference, Albuquerque, NM, pp. 399-412, 1996.
2. Driscoll, M., Rivers, P., 3M, "Clean Extinguishing Agents and Continuously Energized Circuits: Recent Findings," *Proceedings*, Halon Options Technical Working Conference, Albuquerque, NM, pp. 129-140, 1997.
3. Bayless, H., and Niemann, R., "Update on the Evaluation of Selected NFPA 2001 Agents for Suppressing Class 'C' Energized Fires," *Proceedings*, Halon Options Technical Working Conference, Albuquerque, NM, pp. 293-294, 1998.
4. Bengtson, G., Niemann, R., "Update in the Evaluation of Selected NFPA 2001 Agents for Suppressing Class C Energized Fire," *Proceedings*, Halon Options Technical Working Conference, Albuquerque, NM, May 24-26, 2005.

position products when they are exposed to a fire. It is essential that the end user understand this process, since the selection of the discharge time and other design factors will be affected by the amount of decomposition products the protected hazard can tolerate.

The concentration of thermal decomposition products from a halogenated fire suppression agent is dependent upon several factors. The size of the fire at the time of system activation and the discharge time of the suppression agent play major roles in determining the amount of decomposition products formed. The smaller the fire, the less energy (heat) is available to cause thermal decomposition of the suppression agent, and hence the lower the concentration of thermal decomposition products. The size of the fire at the time of system activation is dependent upon the fire growth rate, the detector sensitivity, and the system discharge delay time. The first factor is primarily a function of the fuel type and geometry, whereas the latter two are adjustable characteristics of the fire protection system. The discharge time affects the production of thermal decomposition products, as it determines the exposure time to the fire of sub-extinguishing concentrations of the fire suppression agent. Suppression systems have traditionally employed a combination of rapid detection and rapid discharge to limit both the production of thermal decomposition products and damage to assets by providing rapid flame extinguishment.



The enclosure volume also affects the concentration of thermal decomposition products, since larger volumes, that is, smaller fire size to room volume ratios, will lead to dilution of decomposition products. Additional factors affecting the concentration of thermal decomposition products include vaporization and mixing of the agent, the pre-burn time, the presence of hot surfaces or deep-seated fires, and the suppression agent concentration.

This decomposition issue is not unique to the new clean halogenated agents. The thermal decomposition products resulting from the extinguishment of fires with Halon 1301 have been investigated by numerous authors (Ford, 1972, and Cholin, 1972, for example), and it is well established that the most important Halon 1301 thermal decomposition products from the standpoint of potential toxicity to humans or potential corrosion of electronic equipment are the halogen acids HF and HBr. Concentrations of acid halides produced from Halon 1301 ranging from a few ppm to over 7000 ppm HF and HBr have been reported, depending upon the exact nature of the fire scenario (Sheinson et al., 1981). Smaller amounts of additional decomposition products can be produced, depending upon the particular conditions of the fire. Under certain conditions, thermal decomposition of Halon 1301 in a fire has been reported to produce small amounts of carbonyl fluoride (COF_2), carbonyl bromide (COBr_2), and bromine (Br_2), in addition to relatively large amounts of HF and HBr. Note that all of these products are subject to relatively rapid hydrolysis to form the acid halides HF and HBr (Cotton et al., 1980), and hence these acids constitute the product of primary concern from the standpoint of potential toxicity or corrosion.

As was the case for Halon 1301, the thermal decomposition products of primary concern for the halogenated agents described in this standard are the associated halogen acids, HF in the case of HFCs and PFCs, HF and HCl in the case of HCFC agents, and HF and HI in the case of I-containing agents. As was the case for Halon 1301, smaller amounts of other decomposition products can be produced, depending upon the particular conditions of the fire. In a fire, HFC or PFC agents can potentially produce small amounts of carbonyl fluoride (COF_2). HCFC agents can potentially produce carbonyl fluoride (COF_2), carbonyl chloride (COCl_2), and elemental chlorine (Cl_2), and I-containing compounds can potentially produce carbonyl fluoride (COF_2) and elemental iodine (I_2). All of these products are subject to relatively rapid hydrolysis (Cotton et al., 1980) to produce the associated halogen acid (HF or HCl or HI); hence, from the standpoint of potential toxicity to humans or potential corrosion of electronic equipment, the halogen acids are the decomposition products of concern.

The dependence of decomposition product formation on the discharge time and fire size has been extensively evaluated (Sheinson et al., 1994; Brockway, 1994; Moore et al., 1993; Back et al., 1994; Forssell and DiNenno, 1995; DiNenno, 1993; Purser, 1998; and Dierdorf et al., 1993). Figure A.5.7.1.2(a) is a plot of peak HF concentration as a function of the fire size to room volume ratio. The data encompass room scales of 1.2 m^3 to 972 m^3 . The 526 m^3 results are from U.S. Coast Guard (USCG) testing; the 972 m^3 results are based on NRL testing. These fires include diesel and heptane pool and spray fires. The design concentration in all cases except HCFC Blend A (at 8.6 percent) are at least 20 percent above the cup burner value. For fires where the extinguishment times were greater than 17 seconds, the extinguishment time is noted in brackets. Note that excessively high extinguishment times (>60 sec-

onds), which is generally an indication of inadequate agent concentrations, yield qualitatively high HF concentrations. In addition, Halon 1301 will yield bromine and hydrogen bromide in addition to HF.

The quantity of HF formed in the tests for all of the halocarbon agents tested is approximately three to eight times higher than that formed for Halon 1301 (which also forms bromine and hydrogen bromide). It is important to note that as pointed out by Peatross and Forssell (Peatross et al., 1996), in many of these large fire scenarios the levels of combustion products (e.g., CO) and the high temperatures involved make it unlikely that a person could survive large fires such as these, irrespective of the HF exposure. The iodine-containing agent CF_3I was not tested in the USCG or NRL studies, but other data available on CF_3I indicate that its production of HF is comparable to that of Halon 1301. In addition, elemental iodine (I_2) is formed from CF_3I .

There may be differences between the various HFC/HCFC compounds tested, but it is not clear from these data whether such differences exist. In all the data reported, the fire sources — heptane or diesel pans of varying sizes — were baffled to prevent direct interaction with the agent.

While the above results are based on Class B fuels, fires involving some Class A combustibles produce lower HF concentrations. For example, hazards such as those in electronic data processing and telecommunication facilities often result in fire sizes of less than 10 kW at detection (Meacham, 1993). In many cases in the telecommunication industry, detection at fire sizes of 1 kW is desired (NIST, 1998). Skaggs and Moore (Skaggs et al., 1994) have pointed out that for typical computer rooms and office spaces, the analysis of DiNenno et al. (DiNenno, 1993) employing fire growth models and test data indicate that thermal decomposition product concentrations from the halogenated agents would be comparable to that from Halon 1301.

Tests by Hughes Associates, Inc. (Hughes Assoc., 1995) evaluated the thermal decomposition products resulting from the extinguishment of Class A fires typical of those encountered in telecommunication and electronic data processing (EDP) facilities by HFC-227ea. The test fuels included shredded paper, PC boards, PVC-coated wire cables, and magnetic tape, representing the most common fuel sources expected to burn in a computer room environment. All fires were extinguished with the minimum design concentration of 7 percent HFC-227ea. Figure A.5.7.1.2(b) (Peatross et al., 1996) shows the HF concentration resulting from these tests. Also shown in Figure A.5.7.1.2(b) is the approximate mammalian LC_{50} (Sax, 1984) and the dangerous toxic load (DTL) for humans based upon the analysis of Meldrum (Meldrum, 1993). As seen in Figure A.5.7.1.2(b), the HF levels produced in the computer room were below both the estimated mammalian LC_{50} and DTL curves. Peatross and Forssell (Peatross et al., 1996), in their analysis of the test results, concluded that “from an examination of the HF exposures, it is evident that this type of fire does not pose a toxic threat.” Also shown in Figure A.5.7.1.2(b) are HF levels produced upon extinguishment of Class B fires of various sizes. In the case of these large Class B fires, HF levels in some cases can be seen to exceed the human DTL. It is important to note that, as pointed out by Peatross and Forssell (Peatross et al., 1996), in many of these large fire scenarios the levels of combustion products (e.g., CO) and the high temperatures involved make it unlikely that a person could survive large fires such as these, irrespective of the HF exposure.

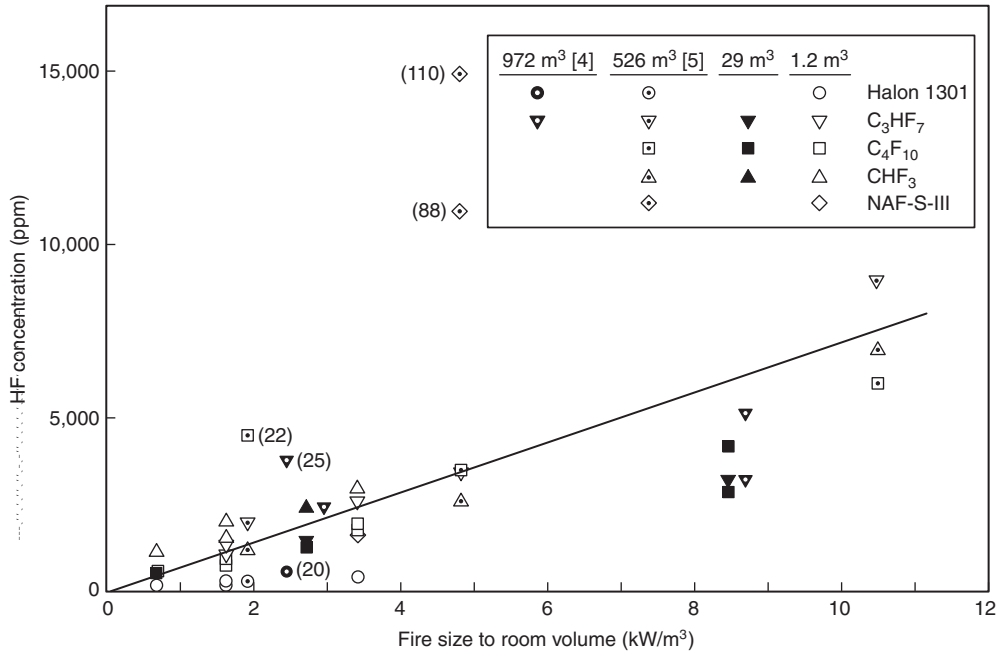

Extinguishment times (seconds) are given in brackets for fires that took longer than 17 seconds to extinguish. If more than one fire was utilized, the longer extinguishment time is given.

FIGURE A.5.7.1.2(a) Peak HF Concentrations.

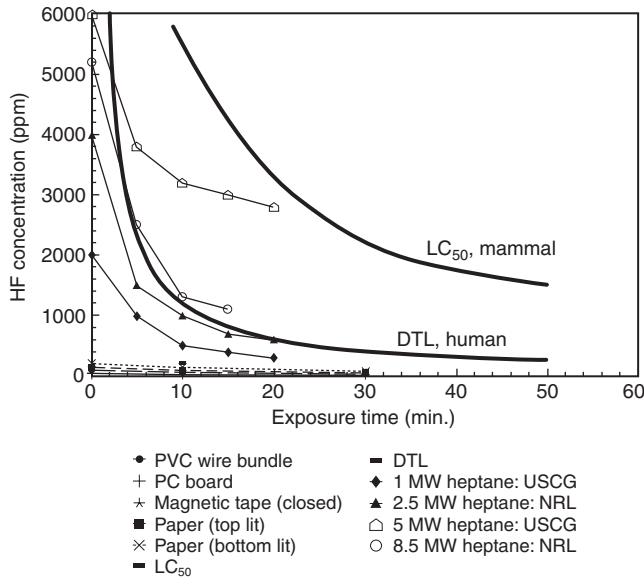

FIGURE A.5.7.1.2(b) Hazard Assessment of HF Concentrations. Extinguishment of Typical EDP and Class B Hazards with 7 Percent HFC-227ea.

Some agents, such as inert gases, will not form decomposition products and hence do not require discharge time limitations on this basis. However, the increased combustion products and oxygen level reduction associated with longer discharge times should be considered.

Agent mass flow rates should be sufficiently high to cause adequate agent mixing and distribution in the compartment. In general, this parameter is determined by the listing of system hardware.

Overpressurization of the protected compartment should also be considered in determining minimum discharge time.

Other secondary flow effects on personnel and equipment include formation of missiles caused by very high discharge velocities, higher noise levels, lifting ceiling panels, and so forth. The likelihood of these effects increases if the maximum discharge time is set too low.

The maximum 10 second discharge time given in this standard reflects a reasonable value based on experience with Halon 1301 systems. The maximum and minimum discharge times should reflect consideration of the factors described above.

For inert gases, the measured discharge time is considered to be the time when the measuring device starts to record reduction of oxygen until the design oxygen reduction level is achieved.

Systems designed for explosion prevention present particular design challenges. These systems typically discharge the agent, before ignition occurs, upon detection of some specified fraction of the lower flammable limit of the flammable vapors present.

A.5.7.1.2.1 The minimum design concentration for flame extinguishment is defined in 5.4.2.2 and includes safety factors for both Class A (surface fires) and Class B hazards. However, many applications involve the use of higher than normal design concentrations for flame extinguishment in order to accomplish the following:

- (1) Provide an initial concentration that will pass minimum holding time requirements
- (2) Allow hot surfaces to cool in order to prevent re-ignition

- (3) Provide protection for electrical equipment that remains energized
- (4) Provide inerting concentrations to protect against the worst-case possibility of explosion of gas vapors, without a fire developing

In the examples cited in A.5.7.1.2.1(1) through A.5.7.1.2.1(4), it is the intent of 5.7.1.2 to allow discharge times greater than 10 seconds for halocarbon agents and greater than 60 seconds for inert gas agents (for that portion of the agent mass that exceeds the quantity required to achieve the minimum design concentration for flame extinguishment). The additional quantity of clean agent is to be introduced into the hazard at the same nominal flow rate required to achieve the flame extinguishing design concentration, using the same piping and nozzle(s) distribution system, or as an alternative, separate piping networks with different flow rates can be used.

A.5.7.1.2.2 See A.5.7.1.2.1.

A.5.7.1.2.3 For third-party listing or approval of pre-engineered systems or flow calculation software for engineered systems (*see* 5.2.1), direct measurement of the point in time at which 95 percent of the agent mass is discharged from the nozzle is not necessary to satisfy compliance with the intent of 5.7.1.2.3. For some agents the measurement of the point in time where 95 percent of the total agent mass coming from a given nozzle is extremely difficult to measure. Rather, for a given agent, a surrogate measurement based on engineering principles can be used. For instance, for some halocarbon agents, the point where the agent discharge changes from predominately liquid to gas represents approximately 95 percent of the agent mass out of the nozzle and has been previously used in the listing/approval testing for discharge time. For low boiling point agents, the point where the agent discharge changes from predominately liquid to gas may not be appropriate because this can occur before the point of 95 percent mass discharged. For such agents a method has been developed that utilizes an equation of state and measured cylinder conditions from the point where the agent discharge changes from predominately liquid to gas to calculate an agent mass balance in the cylinder/pipe network. The experimental discharge time is taken as the point where the summed calculated mass discharged from all nozzles equals 95 percent of the agent required to achieve minimum design concentration.

A.5.7.2 Special consideration should be given to safety and health issues when considering extended discharge systems.

The effect of decomposition products on electronic equipment is a potential area of concern. Sufficient data at present are not available to predict the effects of a given HF exposure scenario on all electronic equipment. Several evaluations of the effect of HF on electronics equipment have been performed relative to the decomposition of Halon 1301, where decomposition products include HF and HBr. One of the more notable was a National Aeronautics and Space Administration (NASA) study where the space shuttle *Orbiter* electronics were exposed to 700, 7000, and 70,000 ppm HF and HBr (Pedley, 1995). In these tests, exposures up to 700 ppm HF and HBr caused no failures. At 7000 ppm, severe corrosion was noted; there were some operating failures at this level.

Dumayas (Dumayas, 1992) exposed IBM-PC compatible multifunction cards to environments produced by a range of fire sizes as part of an evaluation program on halon alternatives. He found no loss of function of these boards following a 15 minute exposure to post-fire extinguishment atmosphere

up to 5000 ppm HF, with unconditioned samples stored at ambient humidity and temperature conditions for up to 30 days. Forssell et al. (Forssell et al., 1994) exposed multifunction boards for 30 minutes in the post-fire extinguishment environment; no failures were reported up to 90 days post-test. HF concentrations up to 550 ppm were evaluated.

While no generic rule or statement can be made at this time, it appears that short term damage (<90 days) resulting in electronic equipment malfunction is not likely for exposures up to 500 ppm HF for up to 30 minutes. This damage, however, is dependent on the characteristics of the equipment exposed, post-exposure treatment, exposure to other combustion products, and relative humidity. Important equipment characteristics include its location in the space, existence of equipment enclosures, and the sensitivity of the equipment to damage.

Extended discharge applications inherently have a performance objective of maintaining the agent concentration at or above the design concentration within the enclosure. This objective is valid if there is mixing of agent continually in the enclosure during the hold period, and the enclosure thereby experiences a decaying concentration over time as opposed to a descending interface. The application of agent should be done with sufficient turbulence to accomplish mixing of the additional agent throughout the enclosure. To accomplish this, the extended discharge probably will need to be performed through a separate network of piping and nozzles. These systems are outside the scope of current design requirements and testing procedures for total flooding systems. Systems should be designed and fully discharge tested on a case-by-case basis until the body of knowledge is sufficient enough to be addressed specifically in this standard.

A.6.1.3 Local concentrations of agent in the vicinity of the discharge often will exceed the maximum permitted exposure limits described in Section 1.5.

A.6.4.1.1 The maximum permitted time for fire extinguishment is based upon extinguishing agent being present at the discharge nozzle. Typically for halocarbon agents this is identified with either a pressure at the nozzle of 25 psi (1.7 bar) or rate of pressure increase of 11 psi/sec (0.8 bar/sec). The times for test fires to be extinguished are from this reference point.

A.6.4.1.2 The maximum permitted time for fire extinguishment is based upon extinguishing agent being present at the discharge nozzle. Typically for inert gas agents this is identified with either a pressure at the nozzle of 200 psi (13.8 bar) or rate of pressure increase of 600 psi/sec (41.4 bar/sec). The times for test fires to be extinguished are from this reference point.

A.6.4.1.3 The nozzle listing evaluation should consider application on fuels including solids and flammable liquids, orientation and angle of discharge, intended area of coverage and the related distance from fire, and extinguishment time and the related discharge rate. Testing of flammable liquids of appreciable depth (over ¼ in.) will consider evaluation of splash and extinguishment. The evaluation for splash will be at maximum rates of flow from minimum pressure loss in the piping limitations and maximum operating temperature of the system. The evaluation for extinguishment will be at minimum rates of flow from maximum pressure loss in the piping limitations and minimum operating temperature of the system.

A.6.4.3.3 The maximum temperature of a burning liquid fuel is limited by its boiling point where evaporative cooling matches the heat input. In most liquids the auto-ignition temperature is far above the boiling temperature, so that re-ignition after extin-

guishment can be caused only by an external ignition source. However, a few unique liquids have auto-ignition temperatures that are much lower than their boiling temperatures. Common cooking oils and melted paraffin wax have this property. To prevent re-ignition in these materials, it is necessary to maintain an extinguishing atmosphere until the fuel has cooled below its auto-ignition temperature.

A.6.5.1 Areas that require multiple nozzles should be considered as part of the listing.

A.6.5.4 Nozzles should be located so that they do not interfere with normal operations and maintenance in the hazard area.

A.6.6 The system should be designed to provide an effective discharge of clean agent promptly before excessive amounts of heat can be absorbed by materials within the hazard. Rapid detection should be considered. The clean agent supply should be located as near to the hazard as practicable and yet not exposed to the fire, and the pipeline shall be as direct as practicable with a minimum number of turns in order to get clean agent to the fire promptly.

A.7.1.4 All inert gas clean agents based on those gases normally found in the earth's atmosphere need not be recycled.

A.7.2.1 Transporting charged containers that have not been tested within 5 years could be illegal. Federal and local regulations should be consulted.

A.7.2.2 These guidelines apply only to the external inspection of containers continuously in service in the fire extinguishing system, and should not be confused with the DOT retest requirements for visual inspection described in CFR 49.

Proper recordkeeping is an important part of every inspection. The inspector should be guided by the following outline to ensure that the minimum information is recorded:

- (1) *Record Tag.* A record tag should be attached to every container being inspected for future reference. The record tag should be marked with date of inspection (month/year), name of individual(s) and company performing the inspection, container serial number, condition of the container (paint, corrosion, dents, gouges, etc.), and disposition.
- (2) *Inspection Report.* A suitable inspection form should be provided on which at least the following information should be recorded: date of inspection (month/year), name of individual(s) and company performing the inspection, DOT specification number, container serial number, date of manufacture, date of previous inspection and/or test, type of protective coating, surface condition (corrosion, dents, gouges, fire damage, etc.), disposition (satisfactory, repaint, repair, scrap, etc.).

A sample of a suitable inspection report form is in Appendix A of CGA C-6.

A.7.5 The manufacturer's maintenance procedure should be guided by the following outline:

- (1) System
 - (a) Check overall physical appearance.
 - (b) Disarm system prior to test.
- (2) Hazard
 - (a) Determine size.
 - (b) Determine configuration.
 - (c) Check for unclosable openings.
 - (d) Determine fuels.

- (e) Determine other aspects of the hazard that could impair effectiveness of the extinguishing systems.
- (3) Supervised circuits
 - (a) Exercise all functions.
 - (b) Check all electrical or pneumatic supervisory circuits for proper operation.
- (4) Control panel
 - (a) Exercise all functions.
 - (b) Check supervision if applicable, of each circuit (including releasing devices) as recommended by the manufacturer.
- (5) Power supply
 - (a) Check routing, circuit breakers, fuses, disconnects.
- (6) Emergency power
 - (a) Check battery condition.
 - (b) Check charger operation; check fuse.
 - (c) Check automatic changeover.
 - (d) Check maintenance of generator (if one exists).
- (7) Detectors
 - (a) Test each detector using heat or smoke or manufacturer's approved test device. (*See NFPA 72.*)
 - (b) Electric type.
 - i. Clean and adjust smoke detector and check sensitivity.
 - ii. Check wiring condition.
 - (c) Pneumatic type.
 - i. Check tightness of tubing and operation of mercury checks, using manometer.
- (8) Time delay
 - (a) Exercise functions.
 - (b) Check time limit.
 - (c) Check that timer will complete its cycle even though wiring between it and the detector circuit is interrupted.
- (9) Alarms
 - (a) Test for operation (audible and visual).
 - (b) Check to see that warning signs are properly displayed.
- (10) Selector (directional) valves
 - (a) Exercise functions.
 - (b) Reset properly.
- (11) Release devices
 - (a) Check for complete closure of dampers.
 - (b) Check doors; check for any doors blocked open.
- (12) Equipment shutdown
 - (a) Test shutdown function.
 - (b) Check adequacy (all necessary equipment included).
- (13) Manual releases
 - (a) Mechanical type.
 - i. Check pull, force, and length of pull required.
 - ii. Operate and adjust all devices.
 - iii. Check tightness of connectors.
 - iv. Check condition of conduit.
 - v. Check condition and operation of corner pulleys.
 - (b) Electric type.
 - i. Test manual release.
 - ii. Check that covers are in place.
 - (c) Check pneumatic releases.
 - (d) Check accessibility during fire.



- (e) Separate main and reserve manual pulls that require only one operation, to obtain discharge of either main or reserve supply of gas.
- (f) Clearly mark and identify all manual releases.
- (14) Piping
 - (a) Check security; check that piping is adequately supported.
 - (b) Check condition; check for any corrosion.
- (15) Nozzles
 - (a) Check orientation and orifice size; make sure it is unchanged from original design.
 - (b) Check cleanliness.
 - (c) Check security.
 - (d) Check seals where needed.
- (16) Containers
 - (a) Check physical condition; check for any sign of corrosion.
 - (b) Check the contents for weight by acceptable methods for each cylinder. If the contents are below the required amount specified in 7.1.3.1 and 7.1.3.2 then the containers must be refilled or replaced. (Proper operation of the liquid level gauge should be verified.)
 - (c) Check that cylinders are securely held in position.
 - (d) Check hydrostatic test date.
 - (e) Check cylinder connectors for integrity and condition.
 - (f) Check weights and cables of mechanical release system.
 - (g) Check release devices; check for proper arrangement and security.
 - (h) Check explosive release devices; check replacement date and check condition.
- (17) Test
 - (a) Perform recommended discharge tests when there is any question about the adequacy of the system.
 - (b) Perform recommended full discharge test when cylinder hydrostatic test is required.
- (18) Return all parts of system to full service.
- (19) Give Certificate of Inspection to owner
 - (a) Regular service contracts with the manufacturer or installing company are recommended. Work should be performed by personnel thoroughly trained and regularly engaged in providing such service.

A.7.5.3 The method of sealing should not introduce any new hazards.

A.7.6.2 Training should cover the following:

- (1) Health and safety hazards associated with exposure to extinguishing agent caused by inadvertent system discharge
- (2) Difficulty in escaping spaces with inward swinging doors that are overpressurized due to an inadvertent system discharge
- (3) Possible obscuration of vision during system discharge
- (4) Need to block open doors at all times during maintenance activities
- (5) Need to verify that a clear escape path exists to compartment access
- (6) A review of how the system could be accidentally discharged during maintenance, including actions required by rescue personnel should accidental discharge occur

A.7.7.2.2.10 A discharge test is generally not recommended.

A.7.7.2.2.13 The purpose is to conduct a flow test of short duration (also known as a “puff test”) through the piping network to determine that the flow is continuous, check valves are properly oriented, and the piping and nozzles are unobstructed.

The flow test should be performed using gaseous nitrogen or an inert gas at a pressure not to exceed the normal operating pressure of the clean agent system.

The nitrogen or an inert gas pressure should be introduced into the piping network at the clean agent cylinder connection. The quantity of nitrogen or an inert gas used for this test should be sufficient to verify that each and every nozzle is unobstructed.

Visual indicators should be used to verify that nitrogen or an inert gas has discharged out of each and every nozzle in the system.

A.7.7.2.3 The leakage and predicted retention time of an enclosure can be determined using the procedure of Annex C, Enclosure Integrity Procedure, or by an alternative method that can be used to obtain an equivalent quantitative result.

A.7.8 Safety should be a prime concern during installation, service, maintenance, testing, handling, and recharging of clean agent systems and agent containers.

One of the major causes of personnel injury and property damage is attributed to the improper handling of agent containers by untrained and unqualified personnel. In the interest of safety, and in order to minimize the potential for personnel injury and property damage, the following guidelines should be adhered to:

- (1) If any work is to be performed on the fire suppression system, qualified fire service personnel, trained and experienced in the type of equipment installed, should be engaged to do the work.
- (2) Personnel involved with fire suppression system cylinders must be thoroughly trained in the safe handling of the containers as well as in the proper procedures for installation, removal, handling, shipping, and filling; and connection and removal of other critical devices, such as discharge hoses, control heads, discharge heads, initiators, and anti-recoil devices.
- (3) The procedures and cautions outlined on the cylinder nameplates, and in the operation and maintenance manuals, owner’s manuals, service manuals, and service bulletins that are provided by the equipment manufacturer for the specified equipment installed, should be followed.
- (4) Most fire suppression system cylinders are furnished with valve outlet anti-recoil devices and in some cases cylinder valve protection caps. Do not disconnect cylinders from the system piping, or move or ship the cylinders, if the anti-recoil devices or protection caps are missing. Obtain these parts from the distributor of the manufacturer’s equipment or the equipment manufacturer. These devices are provided for safety reasons and should be installed at all times, except when the cylinders are connected into the system piping or being filled.
- (5) All control heads, pressure-operated heads, initiators, discharge heads, or other type of actuation devices should be removed before disconnecting the cylinders from the system piping, and anti-recoil devices and/or protection caps immediately installed before moving or shipping the cylinders. Most fire suppression system equipment varies from manufacturer to manufacturer; therefore, it is important to follow the instructions and procedures provided in the equipment manufacturer’s manuals. These actions should only be undertaken by qualified fire suppression system service personnel.

- (6) Safety is of prime concern! Never assume that a cylinder is empty. Treat all cylinders as if they are fully charged. Most fire suppression system cylinders are equipped with high flow rate valves that are capable of producing high discharge thrusts out of the valve outlet if not handled properly. Remember, pressurized cylinders are extremely hazardous. Failure to follow the equipment manufacturer's instructions and the guidelines contained herein can result in serious bodily injury, death, or property damage.

A.8.2.1 Some typical hazards that could be suitable include, but are not limited to, the following:

- (1) Machinery spaces such as main machinery spaces
- (2) Emergency generator rooms
- (3) Pump rooms
- (4) Flammable liquid storage and handling areas and paint lockers
- (5) Control rooms and electronic equipment spaces

A.8.2.2 General cargo should not be protected with halocarbon agents due to the possibility of deep-seated cargo fires and due to wide variations in cargo materials. Dry cargoes, such as containerized cargoes, often include a wide mix of commodities that can include materials or storage arrangements not suited for protection with Halocarbon agents. The volume of agent needed to protect cargo spaces varies depending on the volume of the cargo space minus the volume of the cargo carried. This quantity varies as cargo volume changes and can affect fire extinguishing effectiveness or agent toxicity.

A.8.3.2 Subchapter J of 46 CFR 111.59 requires busways to comply with Article 368 of NFPA 70. Article 368 requires compliance with Article 300 for clearances around busways.

A.8.4.2 Agent cylinder storage spaces should be adequately ventilated. Entrances to such spaces should be from an open deck.

A.8.4.6 Corrosion resistance is required to prevent clogging of nozzles with scale. Examples of suitable materials are hot dipped galvanized steel piping inside and out or stainless steel.

A.8.4.7 Fittings conforming to ASTM F 1387 and fire tested with zero leakage conform to the requirements of 8.4.7.

A.8.5.1.2 The intent of this subsection is to ensure that a suppression system will not interfere with the safe navigation of the vessel. Many internal combustion propulsion engines and generator prime movers draw combustion air from the protected space in which they are installed. Because these types of engines are required to be shut down prior to system discharge, an automatically discharged system would shut down propulsion and electricity supply when needed most. A nonautomatic system gives the ship's crew the flexibility to decide the best course of action. For example, while navigating in a high-density shipping channel, a ship's ability to maneuver can be more important than immediate system discharge. For small vessels, the use of automatic systems is considered appropriate taking into consideration the vessel's mass, cargo, and crew training.

A.8.5.2.3 The intent is to prevent accidental or malicious system operation. Some examples of acceptable manual actuation stations are the following:

- (1) Breaking a glass enclosure and pulling a handle
- (2) Breaking a glass enclosure and opening a valve
- (3) Opening an enclosure door and flipping a switch

A.8.6.1 Heat detectors are typically used in machinery spaces and are sometimes combined with smoke detectors. Listed or approved optical flame detectors can also be used, provided they are additional to the required quantity of heat and/or smoke detectors.

A.8.6.2 This requirement is derived from SOLAS Merchant Marine Circular 9/93, Regulation II-2/Regulation 5.3, Halogenated Hydrocarbon Systems.

A.8.6.3 This requirement is derived from SOLAS Merchant Marine Circular 9/93, Regulation II-2/Regulation 5.3, Halogenated Hydrocarbon Systems.

A.8.6.4 This requirement is derived from SOLAS Merchant Marine Circular 9/93, Regulation II-2/Regulation 5.3, Halogenated Hydrocarbon Systems.

A.8.6.5 This requirement is derived from SOLAS Merchant Marine Circular 9/93, Regulation II-2/Regulation 5.3, Halogenated Hydrocarbon Systems.

A.8.6.6 This requirement is derived from SOLAS Merchant Marine Circular 9/93, Regulation II-2/Regulation 5.3, Halogenated Hydrocarbon Systems.

A.8.7.1 A well-sealed enclosure is vital to proper operation of the system and subsequent extinguishment of fires in the protected space. Gastight boundaries of the protected space, such as those constructed of welded steel, offer a highly effective means for holding the fire extinguishing gas concentration. Where the space is fitted with openings, avenues for escape of the gas exist. Automatic closure of openings is the preferred method of ensuring enclosure integrity prior to discharge. Manually closed openings introduce added delay and an added human element into the chain of proper operation of the system. Failure of personnel to properly close all openings has been a recurring cause of gaseous systems not performing as intended. It is recognized that some openings in the enclosures, such as maintenance hatches and watertight doors, cannot be fitted with automatically operated closers due to personnel hazards or other limitations. In these cases, an indicator is required to alert the system operator that an opening has not been closed as required and thus the system is not ready for operation.

A.8.7.2 Automatic shutdowns are the preferred method for shutting down a ventilation system. Shutdowns requiring personnel to find and manually close dampers far from the fire extinguishing system discharge station should not be permitted.

A.8.8.4 When calculating the net volume of the machinery space, the net volume should include the volume of the bilge and the volume of the stack uptake. The volume calculation should be permitted to exclude the portions of the stack uptake that have a horizontal cross-sectional area less than 40 percent of the horizontal cross-sectional area of the main machinery space. The horizontal cross-sectional area of the main machinery space should be measured midway between the lowest level (tank top) and the highest level (bottom of the stack casing). (See Figure A.8.8.4.)

The objects that occupy volume in the protected space should be subtracted from the volume of the space. These objects include, but are not necessarily limited to, the following:

- (1) Auxiliary machinery
- (2) Boilers
- (3) Condensers
- (4) Evaporators



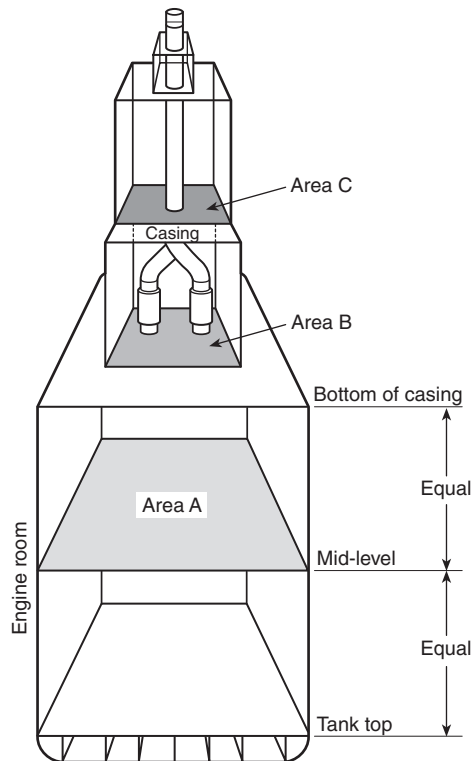

For the casing to be considered separate from the gross volume of the machinery space, Area B must be 40 percent or less of Area A.

If Area B is greater than 40 percent of Area A, the volume of casing up to Area C (or where the area is 40 percent or less of Area A) must be included in the gross volume of the space.

Any area of the casing containing boilers, internal combustion machinery, or oil-fired installations must be included in the gross volume of the engine room.

FIGURE A.8.8.4 Machinery Space and Stack Uptake.

- (5) Main engines
- (6) Reduction gears
- (7) Tanks
- (8) Trunks

The Maritime Safety Committee, at its sixty-seventh session (2 to 6 December 1996), approved guidelines for the approval of equivalent fixed gas fire extinguishing systems, as referred to in SOLAS 74, for machinery spaces and cargo pump rooms, as MSC/Circ. 776.

The Subcommittee on Fire Protection, at its forty-second session (8 to 12 December 1997), recognized the need of technical improvement to the guidelines contained in MSC/Circ. 776 to assist in their proper implementation and, to that effect, prepared amendments to the guidelines.

The committee, at its sixty-ninth session (11 to 20 May 1998), approved revised guidelines for the approval of equivalent fixed gas fire extinguishing systems, as referred to in SOLAS 74, for machinery spaces and cargo pump rooms, as set out in the annex, to supersede the guidelines attached to MSC/Circ. 776.

Member governments are invited to apply the annexed guidelines when approving equivalent fixed gas fire extinguishing systems for use in machinery spaces of category A and cargo pump rooms.

The quantity of extinguishing agent for the protected space should be calculated at the minimum expected ambient temperature using the design concentration based on the net volume of the protected space, including the casing.

The net volume of a protected space is that part of the gross volume of the space that is accessible to the free extinguishing agent gas.

When calculating the net volume of a protected space, the net volume should include the volume of the bilge, the volume of the casing, and the volume of free air contained in air receivers that in the event of a fire is released into the protected space.

The objects that occupy volume in the protected space should be subtracted from the gross volume of the space. They include, but are not necessarily limited to, the following:

- (1) Auxiliary machinery
- (2) Boilers
- (3) Condensers
- (4) Evaporators
- (5) Main engines
- (6) Reduction gears
- (7) Tank
- (8) Trunks

Subsequent modifications to the protected space that alter the net volume of the space require the quantity of extinguishing agent to be adjusted to meet the requirements of 8.8.4 and 8.8.5.

No fire suppression agent should be used that is carcinogenic, mutagenic, or teratogenic at concentrations expected during use. No agent should be used in concentrations greater than the cardiac sensitization NOAEL, without the use of controls as provided in SOLAS Regulation II-2/Regulations 5.2, Carbon Dioxide Systems. In no case should an agent be used above its LOAEL nor approximate lethal concentration (ALC) calculated on the net volume of the protected space at the maximum expected ambient temperature.

A.8.8.5 Maintaining the design concentration is equally important in all classes of fires because a persistent ignition source, such as an electric arc, boiler front, heat source, engine exhaust, turbo charger, hot metal, or deep-seated fire, can lead to resurgence of the initial event once the clean agent has dissipated.

A.8.11.3 When determining container pressure, the original container fill density should be obtained from the system manufacturer and the temperature/pressure relation should be obtained from tables published by the system manufacturer. When determining container liquid level, the liquid level/temperature relationship should be obtained from the system manufacturer.

Annex B Cup Burner Method for Determining the Minimum Concentration of Gaseous Agent for Flame Extinguishment

This annex is not a part of the requirements of this NFPA document but is included for informational purposes only.

B.1 Introduction. Total flooding fire extinguishing systems are widely used for protection of enclosures where flammable materials, including liquids and gases, are processed or stored.¹ The fire extinguishing agent used in such a system may be a gas or a liquid under storage conditions. When released into the atmosphere of the protected space, the agent

disperses, and evaporates if initially a liquid, to form a mixture of air and gaseous agent. Successful fire suppression occurs when the agent concentration exceeds the minimum extinguishing concentration (MEC) by a sufficient margin, or safety margin, to cause rapid flame extinguishment. Use of excessive amounts of agent may be undesirable for reasons related to total system cost or, often more importantly, due to the need to avoid creating an agent-air atmosphere that is itself harmful to people due to considerations of hypoxia, agent toxicity, or both. In the case of flammable liquid hazards the minimum design concentration (MDC) of a gaseous agent is specified in national and international standards as the MEC times a safety factor. This test method uses the cup burner to determine, for a given fuel, the MEC of a gaseous agent. The cup burner method is inherently empirical. The theoretical and parametric aspects of flame extinguishment in this procedure have been addressed by many authors and is the subject of ongoing research. A few recent references are given in the footnotes to the annex.^{2,3,4}

B.2 Scope. Diffusion flames of fuels burning in a round reservoir (cup) centrally positioned in a coaxially flowing air stream are extinguished by addition of a gaseous extinguishing agent to the air.

B.2.1 This test method provides a standard measure of minimum flame extinguishing concentration of a gaseous extinguishing agent for flames of flammable or combustible liquids and flammable gases.⁵

B.2.2 This method has value as a means of meeting the requirements of national and international standards for determination of the minimum design concentration of a gaseous agent.

B.2.3 This method is applicable to gaseous fire extinguishing agents that can be introduced into the test apparatus as a gas that is uniformly mixed in air.

B.2.4 This test method is applicable to liquid fuels that have adequate fluidity at the test temperature to allow accurate liquid level control in the cup. The method may be difficult to use with very viscous fuels.

B.2.5 This method is applicable to fuels that are ignitable at the operating temperature of the cup.

B.2.6 The values stated in SI units are to be regarded as the standard. The values given in parentheses are for information only.

B.2.7 This test method does not purport to address all of the safety concerns, if any, associated with its use. It is the responsibility of the user of this test method to establish appropriate safety and health practices and determine the applicability of regulatory limitations prior to use.

B.3 Referenced Documents.

ASTM E 176, *Terminology of Fire Standards*.

ASTM E 177, *Standard Practice for Use of the Terms Precision and Bias in ASTM Test Methods*.

ASTM E 456, *Standard Terminology for Relating to Quality and Statistics*.

ASTM E 691, *Standard Practice for Conducting an Interlaboratory Study to Determine the Precision of a Test Method*.

ISO 14520, *Gaseous fire-extinguishing systems — Physical properties and system design — Part 1: General requirements* (2000).

UL-2166, *Standard for Halocarbon Clean Agent Extinguishing System Units* (31 March 1999).

UL-2127, *Standard for Inert Gas Clean Agent Extinguishing System Units* (31 March 1999).

B.4 Terminology.

B.4.1 Definitions. For definitions used in this test method refer to NFPA 2001 and ASTM E 176.

B.4.2 Definitions of terms specific to the cup burner method.

B.4.2.1 Agent. Fire extinguishing gas which, when added to air in sufficient quantity, causes extinguishment of the test flame. Agents consisting of non-condensable gases, vapors of liquefied compressed gases, and vapors of volatile liquids are in commercial use.

B.4.2.1.1 Primary Reference Agent. Nitrogen. Minimum purity 99.9%.

B.4.2.1.2 Secondary Reference Agent. Agent more nearly similar to the study agent in extinguishing concentration for the reference fuel than nitrogen.⁶

B.4.2.1.3 Study Agent. Agent which is the subject of study in the cup burner.

B.4.2.2 Cup. Fuel reservoir and flame stabilizer.

B.4.2.3 Chimney. Transparent tube, usually glass, that contains the cup and confines air and agent flow.

B.4.2.4 Flow Straightener. Mechanical means of establishing non-turbulent uniform vertical flow at the base of the chimney.

B.4.2.5 Extinguishing Concentration. The concentration of agent in air that causes extinguishment of the test flame within the observation period.

B.4.2.6 Extinguishment. Cessation of combustion above the cup.

B.4.2.7 Fuel. Flammable or combustible liquid or flammable gas supplied to the cup.

B.4.2.7.1 Reference Fuel.

B.4.2.7.1.1 Liquid reference fuel: n-Heptane. Minimum purity 99%.

B.4.2.7.1.2 Gaseous reference fuel: Methane.⁷ Minimum purity 99%.

B.4.2.7.2 Study Fuel. Fuel for which an extinguishing concentration of an agent is to be determined.

B.4.2.8 Lifted Flame. Flame for which the base becomes lifted above cup rim by at least 10 mm at any non-extinguishing agent concentration. The occurrence of lifted flames should be noted in test report.

B.4.2.9 Minimum Extinguishing Concentration (MEC). The lowest value of extinguishing concentration determined by this method.

B.4.2.10 Observation Period. A period of at least 10 seconds after change in agent flow rate.

B.4.2.11 Pre-Burn Time. Period between ignition of fuel and start of agent flow. The pre-burn time should be 95 seconds \pm 5 seconds.⁸

B.5 Summary of Test Method.

B.5.1 Air is delivered to the base of the chimney. The measurements necessary for determining the air flow rate are recorded.



B.5.2 The air stream passes through a flow straightener to establish uniformly distributed flow and reduce turbulence.

B.5.3 A flame of the test fuel is established at the cup. For a liquid fuel the liquid level in the cup is maintained within prescribed limits. The flow rate of a gaseous fuel is kept at a fixed value.

B.5.4 The flame is allowed to burn in air for a prescribed period of time, the pre-burn time.

B.5.5 Agent is added to the air stream in steps. The measurements necessary for determining the agent flow rate, agent concentration in air, or other relevant data are recorded as appropriate to the specific method of agent flow control.

B.5.6 After each change in agent flow rate, the effect of the agent-air mixture on the flame is observed. If the flame is extinguished during the observation period, the result is recorded as an extinguishing condition and the determination is concluded. Otherwise, then the agent flow rate is increased.

B.5.7 The extinguishing concentration for each determination is calculated or otherwise determined from the data.

B.5.8 At least five determinations of extinguishing concentration are made exclusive of initial trials conducted for the purpose of determining the approximate extinguishing point.

B.5.9 The results of the several determinations of extinguishing concentration are analyzed statistically and reported.

B.6 Significance and Use.

B.6.1 This test method provides a means to determine the MEC in air of a gaseous agent to extinguish flames of a liquid and gaseous fuels.

B.6.2 An MEC value determined by this method is specific to the apparatus and procedure employed herein. The minimum concentration of agent in air necessary to extinguish combustion of the same fuel under other laboratory or field conditions may be different than that determined by this method.

B.6.3 The MEC determined by this method may be used as a basis of determining minimum agent design concentration for a total flooding application in accordance with the requirements of relevant standards for total flooding fire extinguishing systems. In particular, this method meets the requirements of NFPA 2001 for determining the MEC of an agent for a Class B liquid fuel.

B.7 Interferences.

B.7.1 Fuel Character. Some fuels may change character in the cup during the test as a consequence of distillation, chemical reaction, precipitation of solids, or by other means. In such cases the extinguishing concentration determined by this method may not accurately reflect the fuel in its most difficult to extinguish form.

B.7.2 Air. Some laboratories may employ compressed "air" supplied in cylinders by a commercial source. In such instances the "air" must be certified as compressed atmospheric air. Some commercially supplied "air" is prepared by blending previously separated oxygen and nitrogen. The oxygen concentration in such mixtures may deviate significantly from 20.95 mol %, the sea level composition of dry air. Deviation of oxygen concentration from the standard value in supplied "air" will have an effect on the measured extinguishing concentration of the agent. Additionally, the argon content of prepared "air" may deviate from the 0.93 mol % sea level value. Argon has a significantly lower thermal conductivity than nitrogen, and, as such, argon excess or

deficiency could have a measurable effect on the apparent extinguishing of an agent.

B.7.3 Barometric Pressure.⁹

B.7.4 Deposits on Cup Rim. Deposits can cause the liquid fuel to wick down the outside of the cup, making the flame burn from the outside of the cup as well as from the inside.

B.7.5 Humidity. Water vapor is an inert gas fire extinguishing agent. The temperature and relative humidity of air supplied to the chimney should be measured and recorded.

B.7.6 Fuel Overflow. Fuel overflow from the cup into the chimney base invalidates the test.

B.8 Safety Precautions.

B.8.1 Pressurized Equipment. Extinguishing agents may be supplied in pressurized cylinders. Caution must be exercised securing pressurized cylinders, tubing, valves, and fittings.

B.8.2 Combustion Product Ventilation. Combustion products are, in general, hazardous. They may contain carbon monoxide, soot, and partial combustion products, the toxicity of which depends on the fuel chemistry. When halogenated extinguishing agents are tested, combustion will produce halogen acids, such as HF, HCl, HBr and HI, and carbonyl compounds such as COF₂ and COCl₂. An adequate means of ventilation should be employed to exhaust combustion products away from the work space.

B.8.3 General Fire Hazard. There is an attendant general flammable liquids fire hazard associated with conducting cup burner tests. Test technicians should understand this hazard and be trained to respond appropriately in the event of a fuel spill or uncontrolled fuel ignition.

B.9 Apparatus.

B.9.1 Cup Burner Apparatus. The basic cup burner apparatus consists of the following elements: base assembly, chimney, cup, and flow straightener. This apparatus is shown schematically in Figure B.19(a).¹⁰

B.9.1.1 Base Assembly. The base assembly securely supports the chimney, cup, and flow straightener. The base assembly has the following provisions:

- (1) To admit air and agent to a plenum below the flow straightener
- (2) To admit fuel to the cup liquid connection
- (3) For electrical connections or other means of cup heating
- (4) For thermocouples or other temperature measuring means

B.9.1.2 Chimney. The chimney consists of a standard 90 mm ± 1.3 mm O.D. glass tube with 2.4 mm ± 0.3 mm wall thickness suitable for high temperature use.¹¹ The overall chimney tube length is sufficient to accommodate the following minimum dimensions:

- (1) Flow straightener to cup rim: 250 mm (nominal)
- (2) Cup rim to top of chimney: 300 mm (nominal)

B.9.1.3 Fuel Supply.

B.9.1.3.1 Liquid Fuel Reservoir. Liquid fuel should be supplied from a reservoir that permits adjustment of the liquid fuel height in the cup. In one method, fuel is supplied by gravity flow from a reservoir mounted on a means of adjusting its height, such as on a laboratory jack stand. The fuel reservoir should be several times larger in diameter than the cup to

minimize change in the fuel liquid level during a test. Several methods are available for maintaining a constant reservoir liquid level.

B.9.1.3.2 Gaseous Fuel Supply.

B.9.1.4 Cup.

B.9.1.4.1 Body. The cup should be made of quartz or other glass suitable for high temperature use. The nominal dimensions of the cup at the top are: O.D. = 31 mm; I.D. = 21.5 mm. The cup rim has a 45 degree internal chamfer fully crossing the glass annulus. The dimensional details and shape of the upper portion of the cup should be as shown in Figure B.19(b).¹²

B.9.1.5 Cup Preparation for Gaseous Fuels. When gaseous fuels are used, it is necessary to place packing material or screening in the cup in such a manner as to facilitate uniform fuel gas flow across the exit face of the cup. There is discretion on how this is achieved.¹³

B.9.1.5.1 Heating Element. A means of heating liquid fuel in the cup may be incorporated by any method that does not cause localized boiling of liquid fuel on the heating surface. Methods found suitable include use of a heating element immersed in the fuel (fully below liquid surface) or use of a heating element contained within the glass wall of the cup.

B.9.1.5.2 Temperature Measurement. A means of measuring fuel temperature prior to ignition is needed. An in situ thermocouple (below liquid surface) for fuel temperature measurement during a test can prove convenient.

B.9.1.6 Flow Straightener. The flow straightener is a means of assuring uniform non-turbulent upward air velocity at the base of the chimney. A suitable flow straightener can employ a bed of glass beads above the air inlet plenum or other flow straightening materials.

B.9.2 Gas Flow Rates and Agent Concentration Measurement.

B.9.2.1 Air Supply.

B.9.2.1.1 Flow Rate. Measurement of air flow rate can be made with any of several types of flow meters including rotameters, mass flow meters, and bubble flow meters.

B.9.2.1.2 Humidity. Air supplied to the cup burner should be dry.¹⁴

B.9.2.2 Agent.

B.9.2.2.1 Gaseous Agent. Measurement of gas or vapor flow rate may be made with any of several types of flow meters including rotameters, mass flow meters, and bubble flow meters.

B.9.2.2.2 Liquid Agent. The method employed to deliver and vaporize an agent that is a liquid at ambient conditions should be reported.

B.9.2.2.3 Agent Concentration. Direct measurement of agent concentration in the agent-air stream is measured using any of several possible methods including, but not limited to, the following:

- (1) Gas chromatographic, infrared absorption, or other type of analysis of discrete air-agent samples
- (2) Continuous sampling and measurement by detector based on thermal conductivity, infrared absorption, or other measuring principle

B.9.2.2.4 Oxygen Concentration. Agent concentration can, in some instances, be inferred with sufficient accuracy from deter-

mination of the oxygen concentration in the agent-air mixture. Oxygen concentration in gases is commonly measured using methods based on paramagnetic or electrochemical sensors. Interference effects, if any, of agent gas on oxygen concentration measurement must be determined and accounted for.

B.9.3 Gaseous Fuel. Measurement of gaseous fuel flow rate may be made with any of several type of flow meters including rotameters, mass flow meters, bubble flow meters, or other means.

B.10 Calibration and Standardization.

B.10.1 Measuring equipment should be calibrated on a regular basis and whenever test conditions indicate that re-calibration is necessary.

B.10.2 The measurement uncertainty or precision of measuring equipment should be determined and recorded.

B.10.3 The vertical alignment of the chimney should be verified periodically. A spirit level should suffice for this purpose.

B.10.4 The cup should be aligned vertically and be concentric with the axis of the chimney.

B.10.5 Flow regulating valves, where used, should be sized for the anticipated flow rate and should not leak at the pressurized connections.

B.10.6 System Calibration. System calibration tests should be conducted using n-heptane (reference fuel) and at least two reference agents.

B.10.6.1 Primary Reference Agent. Nitrogen should be employed as the primary reference agent.

B.10.6.2 Second Reference Agent. The second reference agent should be selected from among those for which consensus data is available and which has extinguishing performance nearer to the study agent.

B.10.6.3 Calibration Interval. The interval between system calibrations should be short enough to assure that measurable changes in results are detected and causes identified and corrected.

B.10.7 Standardization.

B.10.7.1 Evaluation of a study fuel with a reference agent should include a standardization test using a reference fuel with the reference agent.

B.10.7.2 Evaluation of a study agent with a reference fuel should include a standardization test using a reference agent with a reference fuel.

B.10.7.3 Evaluation of a study agent with a study fuel should include the two following standardization tests:

- (1) A reference agent test using a reference agent with the study fuel
- (2) A reference fuel test using the study agent with a reference fuel

B.11 Test Specimens.

B.11.1 Air. Air should be supplied as compressed natural air either filtered (for oil mist, particulate matter, and moisture condensate) from a local compressor drawing in fresh ambient air or from high pressure cylinders of certified compressed air. Air prepared by re-mixing previously separated oxygen and nitrogen should not be used.

B.11.2 Fuel. The fuel should be of a certified type and purity.

B.11.3 Agent. The agent should be of a certified type and purity or composition.

B.12 Conditioning.

B.12.1 Laboratory Temperature. Tests should be conducted at ambient laboratory temperature, nominally in the range of 20°C to 25°C.

B.12.2 Fuel Temperature. Fuel in the cup should be brought to a temperature of 20°C to 25°C, or $5 \pm 1^\circ\text{C}$ above its open cup flash point, whichever is higher.

B.12.3 Barometric Pressure. Barometric pressure should be measured and recorded.

B.13 Procedure.

B.13.1 Liquid Fuels.

B.13.1.1 Establish air flow in chimney at $40 \text{ L} \pm 2 \text{ L/min}$ at laboratory ambient conditions.¹⁵

B.13.1.2 Admit liquid fuel to the cup, bringing the liquid level to about 5 to 10 mm below the cup rim.

B.13.1.3 Adjust the temperature of fuel as required by B.12.2.

B.13.1.4 Ignite the fuel.

B.13.1.5 Begin the measurement of pre-burn time.

B.13.1.6 At the start of the pre-burn period, the liquid level of the fuel is raised to within 1 mm of the cup rim or as close to the rim as is practicable without overflowing the cup. The fuel liquid level is to be maintained at this position during the test.

B.13.1.7 At the end of the pre-burn time, begin agent addition.

B.13.1.8 Agent Addition.

B.13.1.8.1 Agent is added to the air flow in steps. After each change in agent flow rate, the flame is observed for a period long enough to make measurements, but not less than 10 seconds, before increasing the agent flow rate.

B.13.1.8.2 Begin addition of agent to the air stream. Where the extinguishing point is known approximately, the initial agent flow rate can be brought to about 80 percent of that value. Subsequent increases in agent flow rate should be no more than 2 percent and should be smaller as the extinguishing point is approached. The agent flow rate, or other characteristic measure of agent concentration, should be recorded at each adjustment of agent flow as the extinguishing point is approached. Experience and judgement will determine how small agent flow adjustments should be at any point during the test, and when to record such pre-extinguishment data.

B.13.1.8.3 If the flame is not extinguished during the 10-second observation period, then the agent flow rate is increased. This step is repeated until flame extinguishment occurs.

B.13.1.8.4 The agent flow rate at extinguishment is recorded.¹⁶

B.13.1.9 The temperature of the fuel at the time of extinguishment can be measured and recorded. This is supplementary information that can be helpful in analysis of results in some cases.

B.13.1.10 At the conclusion of each test, the fuel liquid level should be lowered several millimeters. A pipette should be employed to remove at least 10 mL of liquid fuel from the top of the cup to remove decomposition products of both the fuel and agent and, where the fuel is a mixture, to remove fuel

concentrated in species of higher boiling point due to preferential evaporation of lighter species at the surface.

B.13.1.11 Number of Test Trials. A determination of extinguishing concentration should be based on results from at least five (5) test trials in sequence, exclusive of initial trials, conducted for the purpose of determining the approximate extinguishing point.

B.13.2 Gaseous Fuels.

B.13.2.1 Establish air flow in the chimney to achieve a nominal air velocity at the cup–chimney annulus of $13.6 \text{ cm} \pm 0.7 \text{ cm/sec}$ (volumetric air flow rate of $\approx 40 \text{ L} \pm 2 \text{ L/min}$ in an 85 mm inside diameter chimney with a cup diameter of 31 mm) at laboratory conditions of pressure and temperature.

B.13.2.2 Measure and record air temperature and humidity.

B.13.2.3 Admit gaseous fuel to the cup and ignite.

B.13.2.4 Fuel Flow Rate and Flame Size. Adjust the fuel gas flow rate to achieve a visible flame height of about 75 mm to 85 mm.¹⁷

B.13.2.5 Begin the measurement of pre-burn time.

B.13.2.6 At the end of the pre-burn time, begin agent addition.

B.13.2.7 Agent Addition.

B.13.2.7.1 Agent is added to the air flow in steps. After each change in agent flow rate, the flame is observed for a period long enough to make measurements, but not less than 10 seconds, before increasing the agent flow rate.

B.13.2.7.2 Begin addition of agent to the air stream. Where the extinguishing point is known approximately, the initial agent flow rate can be brought to about 80 percent of that value. Subsequent increases in agent flow rate should be no more than 2 percent. The agent flow rate, or other characteristic measure of agent concentration, should be recorded at each adjustment of agent flow as the extinguishing point is approached. Experience and judgement will determine how small agent flow adjustments should be at any point during the test, and when to record such pre-extinguishment data.

B.13.2.7.3 If the flame is not extinguished during the 10-second observation period, then the agent flow rate is increased. This step is repeated until flame extinguishment occurs.

B.13.2.7.4 The agent flow rate at extinguishment is recorded.¹⁶

B.13.2.8 At the conclusion of each test, the cup rim should be checked for deposits (soot) and cleaned if required.

B.13.2.9 Number of Test Trials. A determination of extinguishing concentration should be based on results from at least five (5) test trials in sequence, exclusive of preliminary ranging trials.

B.14 Agent Concentration.

B.14.1 General. The concentration of interest is that of the agent gas in the agent–air mixture. Concentration is often expressed as “volume percent” but this is not strictly correct, as concentration is actually a measure of quantity of substance per unit volume (e.g., mol/L or g/L). Volume percent is a measure of the volume fraction of an air–agent mixture that consists of agent gas. This measure is convenient in practice and is not discouraged as long as it is determined correctly. Caution is recommended in cases where the density of agent vapor, either pure or diluted in air, departs measurably from

that of an ideal gas of the same molecular weight. It is recommended that concentration be calculated as mole fraction or mole percent. The supplier of each agent can guide their users as to conversion to volume percent for use in fire extinguishing system design.

B.14.2 Flow Rate Methods.

B.14.2.1 Volumetric Flow Rate. Volumetric flow rate air or agent, measured using calibrated flow meters, should be converted to molar flow rate by multiplying by the gas density and dividing by the agent mean molecular weight. To determine the density of some agent gases it may be necessary to consult the physical property data (table or equation of state) supplied by the manufacturer.

B.14.2.2 Mass Flow Rate. Where a calibrated mass flow rate measuring device is used, convert the mass flow rate to molar flow rate by dividing by the molecular weight. $N = \text{Molar flow rate} = \text{mass flow rate} / \text{molecular weight}$

B.14.2.3 Calculate mole fraction, X_G , of agent in the agent-air mixture.

$$X_G = \frac{N_G}{N_G + N_{Air}}$$

where:

N_g = molar flow rate of gas
 N_{Air} = molar flow rate of air

B.14.2.4 Calculate the agent concentration in mole percent as

$$\text{Mole \% Agent} = 100X_G$$

B.14.3 Direct Gas Analysis Method. Any of several types of gas analyzers can be calibrated with prepared agent-air mixtures of known composition.

B.14.3.1 Continuous Sampling Analyzer. If the analyzer is of the continuous sampling type, the gas analyzer can then be used to measure the agent concentration in sample of air-agent mixture drawn from the flowing stream during the test and in particular at the times just before and just after flame extinguishment.

B.14.3.2 Discrete Sample Analyzer. Agent concentration can be determined by analyzing a sample of the agent-air mixture in a gas chromatograph or other calibrated gas analyzer.

B.14.4 Oxygen Analyzer Measurement Method. The concentration of agent in an agent-air mixture can be calculated from a measurement of oxygen concentration in the mixture. Dry atmospheric air consists of 20.95 mole % oxygen.¹⁸ The concentration of a diluting ideal gas (agent) is given by the following equation.

$$\% \text{ Agent} = \left(1 - \frac{\% \text{O}_2}{20.95}\right) \times 100$$

Where the source air is not atmospheric air, the actual oxygen concentration of the source air (in volume or mole %) should be substituted for the value 20.95 in the above equation. It should be verified that the agent gas does not have an interference effect oxygen analyzer response.

B.14.5 Statistics. The results of the separate determinations of extinguishing concentration should be used to determine average and standard deviation.

B.15 Test Report.

B.15.1 The test report should contain the following information:

- (1) Apparatus description
- (2) Summary of test procedure and exceptions
- (3) Date of report
- (4) Fuel name and grade
- (5) Agent type and composition
- (6) Test conditions, including the following:
 - (a) Barometric pressure
 - (b) Laboratory temperature, or temperature of air entering base of chimney, if different from laboratory temperature
 - (c) Humidity of air supplied to chimney
- (7) Air flow rate at test conditions
- (8) Fuel temperature to be calculated using the following steps:
 - (a) Measure and record fuel temperature prior to ignition.
 - (b) Measure and record fuel temperature at flame extinguishment
- (9) Agent flow rate at test conditions, if measured
- (10) Gas analyzer measurements, if used
- (11) Sample calculation of agent concentration
- (12) Summary table of results, including the following:
 - (a) Data for each combination of agent and fuel tested including results of the following:
 - i. Calibration tests
 - ii. Standardization tests
 - iii. Study tests
 - (b) Sample statistics, including the following:
 - i. Number of measurements, n
 - ii. Average extinguishing concentration (see B.15.2 for the method of calculating this concentration)
 - iii. Standard deviation (see B.15.3)
- (13) Comparison of study results with standardization
- (14) Notes on exceptions in the apparatus, procedure, and analysis

B.15.2 Average extinguishing concentration can be calculated using the following equation:

$$\bar{x} = \frac{1}{n} \sum_{i=1}^n x_i$$

B.15.3 Standard deviation can be calculated using the following equation:

$$s = \sqrt{\frac{\sum_{i=1}^n (x_i - \bar{x})^2}{(n-1)}}$$

B.16 Precision and Bias.

B.16.1 Precision.

B.16.1.1 Repeatability. The repeatability should be calculated as follows. [To be developed]

B.16.1.2 Reproducibility. (Reserved)

B.16.2 Bias. (Reserved)



B.17 Keywords.

B.17.1 cup burner, extinguishing concentration, gaseous agent

B.18**Notes:**

¹The large majority of total flooding fire extinguishing systems are used for protection of Class A fire hazards such as data centers, clean rooms, telephone central offices, control rooms. These occupancies do not normally contain Class B fire hazards.

²Preece, Stephen, Paul Mackay and Adam Chattaway, *The Cup Burner Method — A Parametric Analysis of the Factors Influencing the Reported Extinguishing Concentrations of Inert Gases*, Proceedings of the Halon Options Technical Working Conference, April 24–26, 2001, Albuquerque, NM, May 13–15, 2003.

³Senecal, Joseph A., *Flame Extinguishing by Inert Gases: Theoretical and Experimental Analysis*, Proceedings of the 2004 Technical Meeting of the Central States Section of the Combustion Institute, Austin, TX, March 21–22, 2004.

⁴Takahashi, Fumiaki, Gregory T. Linteris, and Viswanath R. Katta, *Suppression of Cup-Burner Flames*, Fourth International Symposium on Scale Modeling (ISSM-IV), Cleveland, OH, September 17–19, 2003.

⁵Flames of gaseous fuels behave differently than liquids in this test. Gaseous fuel flow is fixed at the start of the test. Liquid fuel vapor flow decreases as the extinguishing point is approached due to reduction in heat transfer rate. Also see Linteris, G.T., *Suppression of Cup-Burner Flames by Super-Effective Chemical Inhibitors and Inert Compounds*, Proceedings of the Halon Options Technical Working Conference, April 24–26, 2001, Albuquerque, NM, pp. 187–196. Figures 1 and 2 illustrate the relationship of liquid fuel consumption rate and agent concentration.

⁶CO₂ might serve well as a secondary reference agent, as it is readily available and has an extinguishing concentration approximately 2/3 that of nitrogen, thereby establishing a significant span useful in establishing benchmark performance.

⁷Fumiaki Takahashi commented: Methane, a main ingredient of natural gas, is favorable because its reaction mechanism is most known and thus most widely used in combustion research. Accurate numerical predictions can be made with full chemistry. However, as Irv Glassman has frequently mentioned, methane (C₁) is unique kinetically compared to higher hydrocarbons. Ethane (C₂) represents kinetics of higher hydrocarbons more closely as they decompose to smaller HCs and the oxidation reaction pathway is ethane to ethylene then to acetylene. When I was in Dayton (UDRI, on-site at WPAFB), Sandia, NM, specifically requested us to use ethane as the fuel for the extinguishing nitrogen concentration measurement in step-stabilized flames. Propane is another popular fuel and attractive for research use, although it (C₃) is also somewhat unique kinetically. Therefore, methane and propane may be practically reasonable, but ethane may be more scientifically sound. (July 8, 2004.)

⁸NFPA 2001 (2004 ed., Annex B) specification is “90 to 120 sec” for liquids and 60 sec for gases. At the recommendation of the VdS representative, ISO TC 21/SC 8 opted in September 2003 for a 60 ± sec pre-burn time for liquid fuels and 60 sec pre-burn time with no tolerance, for gaseous fuels.

⁹It has yet to be demonstrated whether barometric pressure variation from 101.3 Pa affects results obtained in this test. A controlled experimental effort is needed.

¹⁰Simplified apparatus without heater recommended by FK and MLR. Dimensioned cross-sectional drawing needed.

¹¹The specified chimney dimensions are standard and available in Pyrex[®] and Kimax[®] brand tube.

¹²The cup diameters given are from the ICI design, which employs a two-layer design that allows a platinum heating wire to be wrapped around the cup. The outside diameter of the cup is deemed more important than the inside diameter. The liquid pool diameter just below the chamfer is about 25 to 27 mm.

¹³Takahashi et al. (2003) filled the cup with 3 mm glass beads and placed two layers of 40 mesh screen on top.

¹⁴A systematic study by Kidde, plc, showed that for one halo-carbon agent, the extinguishing concentration was linearly related to the humidity of the supplied air. The MEC for 100 percent R.H. air (~21°C) was ~11 percent (relative) less than that determined for ~0 percent R.H. air. (Reference: P. Mackay memorandum, 18 May 2004.) In addition, analysis (July 2004 by J.A. Senecal) of humidity effects on inert gas (nitrogen) extinguishment indicates that feasible variations in humidity of air supplied to the cup burner can affect the extinguishing concentration, X_G. Specifically, it is estimated that in the two extremes of (a) dry air and (b) 70 percent R.H. air at 25°C, the variation in X_G is approximately 0.313 < X_G < 0.295, or 6 percent, which is at least twice the estimated uncertainty of the measurement. An R.H. correction to results may be necessary.

¹⁵(a) The air flow rate should be 40 L ± 2 L/min which, for the standard chimney and cup configuration specified herein, corresponds to a superficial linear velocity in the cup-chimney annulus of 13.5 ± 0.7 cm/sec. The air flow rate should be adjusted in consideration of the actual chimney and cup dimensions to achieve the same nominal annular air velocity. (b) The literature has discussed a “plateau” region in the air flow rate (i.e. a range of air velocities over which the MEC value is invariant, or nearly so). Most investigators report that the plateau for halocarbon agents is usually at or near 40 L/min. It is also reported that there is no plateau for inert gas agents and the MEC value creeps up with increasing air velocity.

¹⁶The goal is to determine that agent concentration in at the extinguishing point. Methods that do not use direct measurement of agent flow rate are permitted. For example, composition analysis of agent-air mixture is acceptable.

¹⁷Takahashi et al. (2003) studied a methane flame. They used an air flow velocity of 10.7 cm/sec (volumetric rate of ~36 L/min) and a methane cup-exit velocity of 0.92 cm/sec (flow rate ~0.34 L/min). This corresponds to an overall equivalence ratio of about 0.090 (i.e., about 900 percent excess air for complete combustion). The uninhibited flame height was ~75 mm.

B.18.1 Other References.

Preece, Stephen, Paul Mackay and Adam Chattaway, *The Cup Burner Method — A Parametric Analysis of the Factors Influencing the Reported Extinguishing Concentrations of Inert Gases*, Proceedings of the Halon Options Technical Working Conference, April 24–26, 2001, Albuquerque, NM, May 13–15, 2003.

Senecal, Joseph A., *Flame Extinguishing by Inert Gases: Theoretical & Experimental Analysis*, Proceedings of the 2004 Technical Meeting of the Central States Section of the Combustion Institute, Austin, TX, March 21–22, 2004.

Takahashi, Fumiaki, Gregory T. Linteris, and Viswanath R. Katta, *Suppression of Cup-Burner Flames*, Fourth International Symposium on Scale Modeling (ISSM-IV), Cleveland, OH, September 17–19, 2003.

B.18.2 Additional Notes.

See *Handbook of Chemistry and Physics*, 83rd ed., David R. Lide, editor, Ch. 14, p. 19 "U.S. Standard Atmosphere (1976)", CRC Press LLC (2002).

See *Handbook of Chemistry and Physics*, 83rd ed., David R. Lide, editor, Ch. 14, p. 19 "U.S. Standard Atmosphere (1976)", CRC Press LLC (2002).

Flames of gaseous fuels behave differently than liquids in this test. Gaseous fuel flow is fixed at the start of the test. Liquid fuel vapor flow decreases as the extinguishing point is approached due to reduction in heat transfer rate. Also see Linteris, G.T., *Suppression of Cup-Burner Flames by Super-Effective Chemical Inhibitors and Inert Compounds*, Proceedings of the Halon Options Technical Working Conference, April 24-26, 2001, Albuquerque, NM, pp. 187-196. Figures 1 and 2 illustrate the relationship of liquid fuel consumption rate and agent concentration.

CO₂ might serve well as a secondary reference agent as it is readily available and has an extinguishing concentration ~ 2/3 that of nitrogen thereby establishing a significant span useful in establishing benchmark performance.

B.19 Figures. Figures B.19(a) through (h) and Table B.19 illustrate critical components for use in fabricating a standard cup burner system.

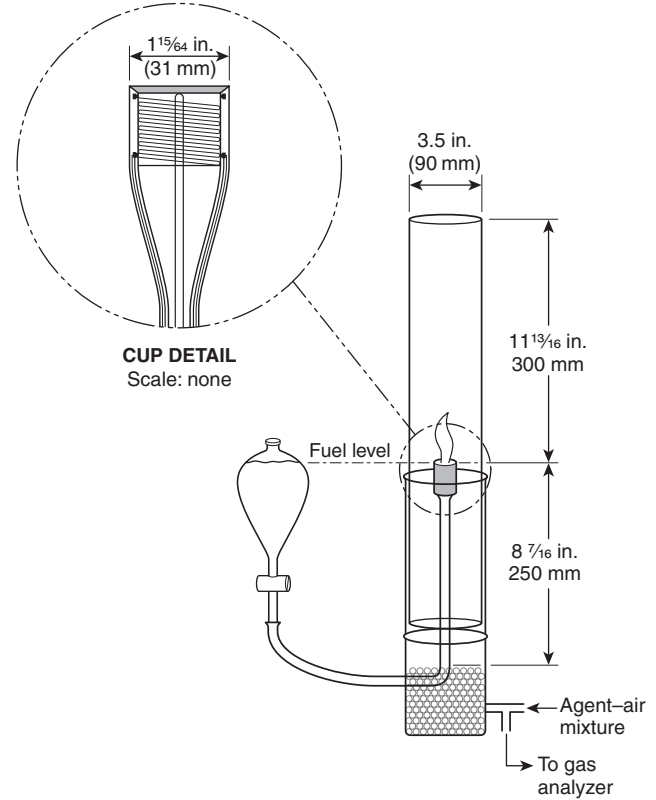

FIGURE B.19(a) Cup Burner Apparatus.

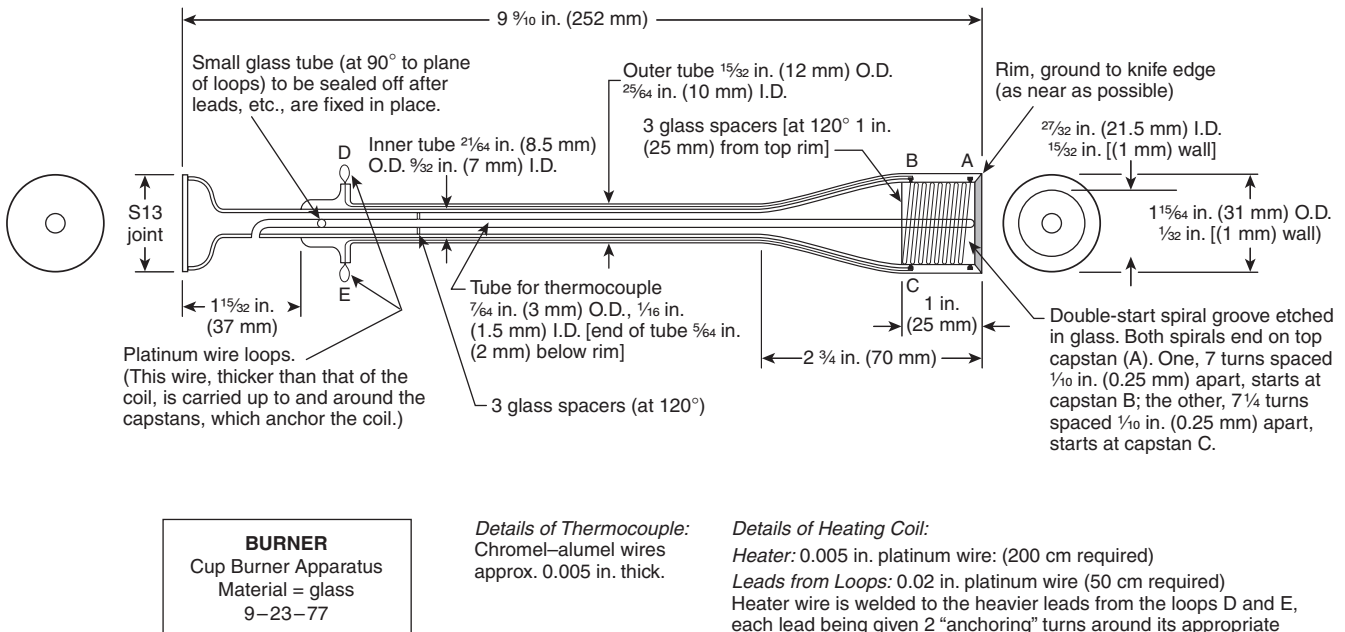

FIGURE B.19(b) Details of Cup Design. Used by Permission of ICI.



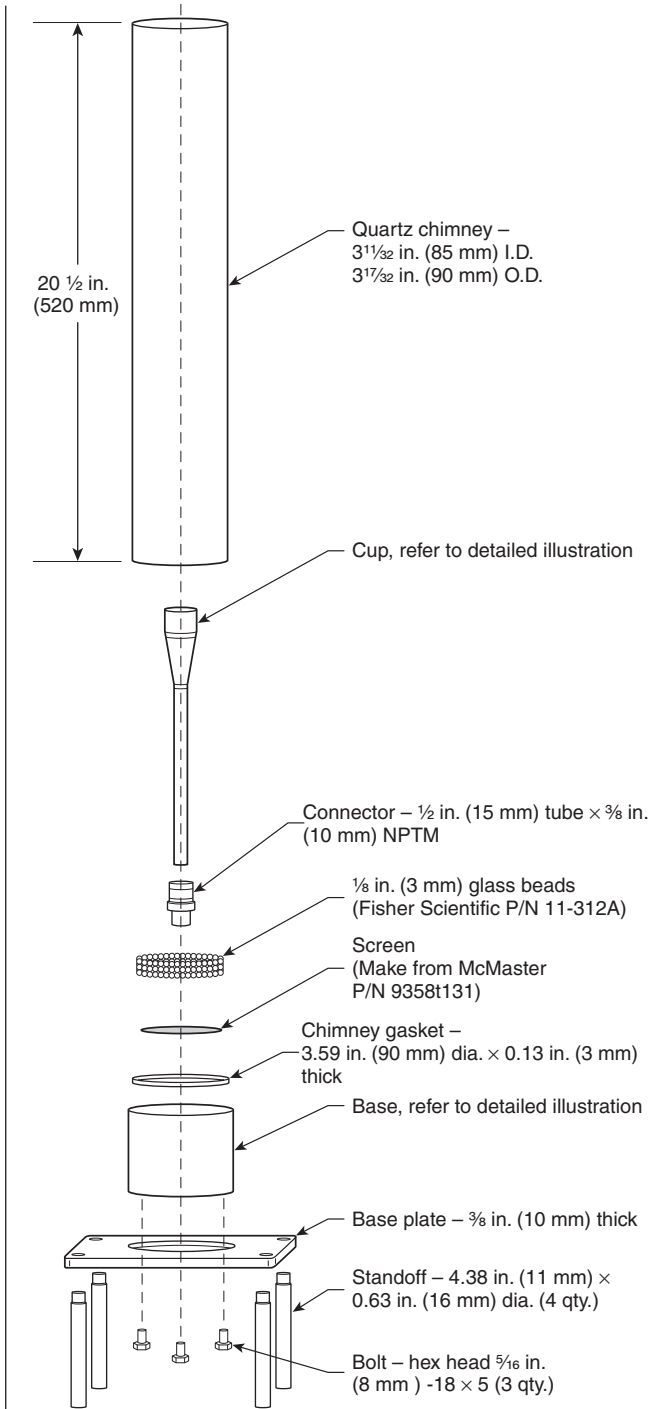

FIGURE B.19(c) Cup Burner Assembly (Exploded View).

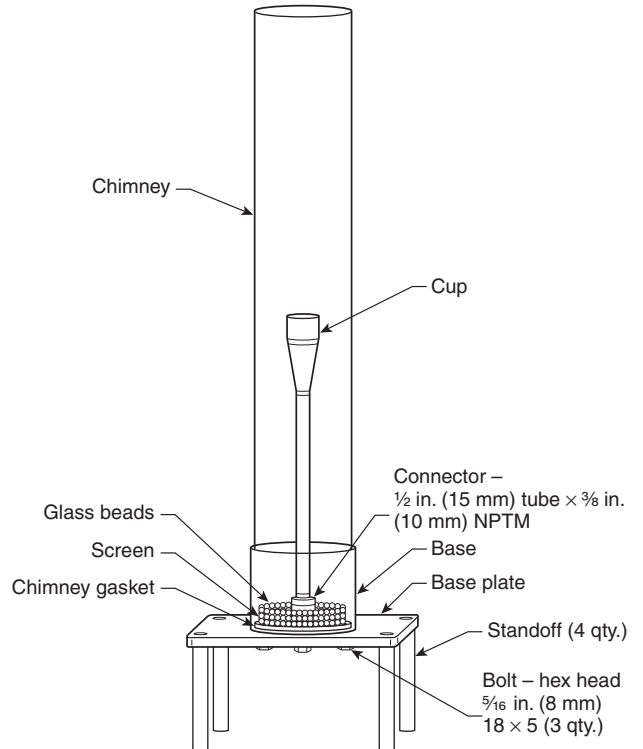
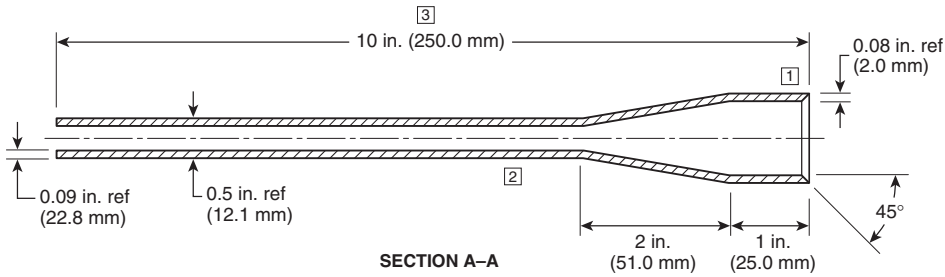

FIGURE B.19(d) Cup Burner Assembly (Transparent View).



Notes:

- 1. Cut 45° to as close to knife point as possible.
- 2. All transitions should be smooth.
- 3. All non-reference dimensions are nominal.

Source:

G. Finkenbeiner Inc.
33 Rumford Ave.
Waltham, MA 02453

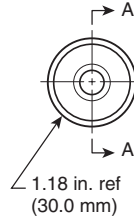

FIGURE B.19(e) Cup Material: Quartz [Dimension in Inches (mm in brackets)].

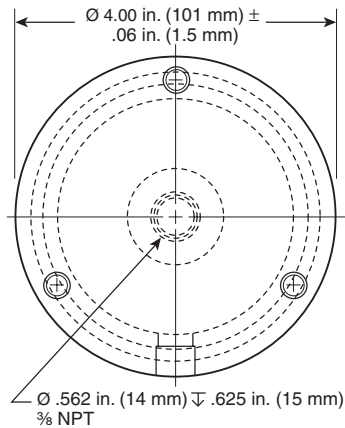
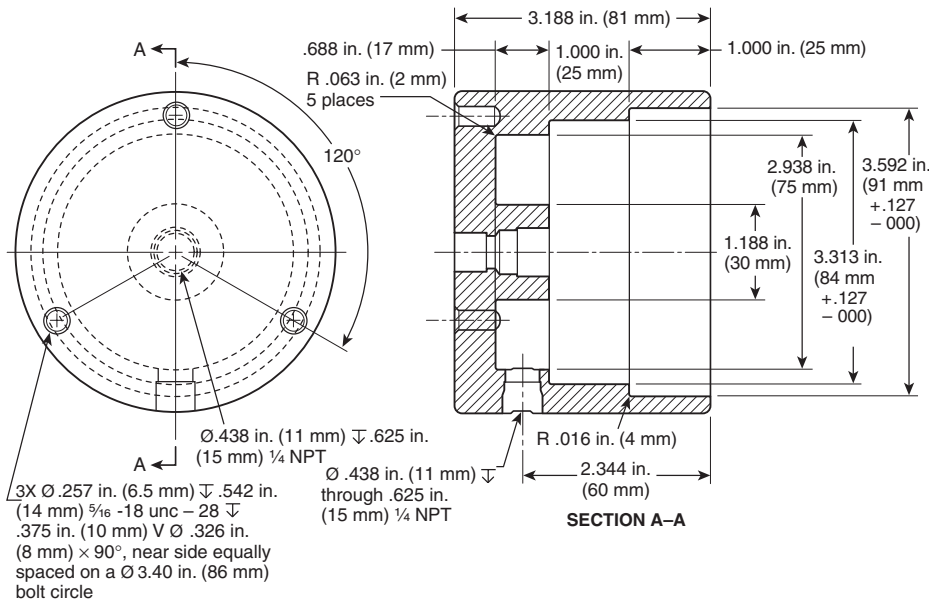

FIGURE B.19(f) Base, Detail.

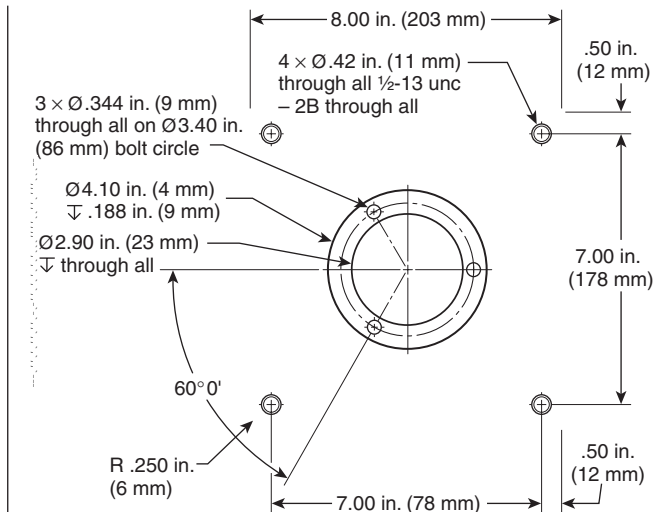

FIGURE B.19(g) Base Support Plate, $\frac{3}{8}$ in. Thick.

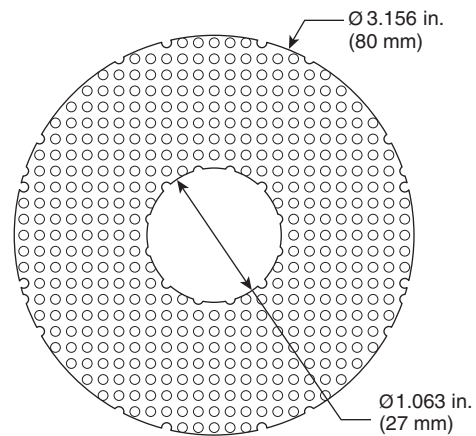

FIGURE B.19(h) Diffuser Bead Support Screen. (Material: 304 SS, 0.030 in. Thick.)

Table B.19 Cup Burner System Major Components

Component	Specification	Supplier
Cup-burner base	Design: per figure 4 Material: Brass	Custom fabrication
Cup-burner base Support plate	Design: per figure 5 Material: Brass	Custom fabrication
Chimney	90 mm OD \times 85 mm ID \times 520 mm (nominal) Material: Quartz	National Scientific Company, Inc 205 East Paletown Road P.O. Box 498 Quakertown, PA 18951 USA
Cup	Design per figure 3 Material: Quartz	G. Finkenbeiner Inc., 33 Rumford Ave., Waltham, MA 02453 or other laboratory glass fabricator
Adapter, NPT to glass tube	Swagelock p/n SS-8-UT-1-6, SS Ultra-Torr Male Connector, $\frac{1}{2}$ in. Female Vacuum Seal Fitting - $\frac{3}{8}$ in. MNPT	Cambridge Valve & Fitting, Inc. 50 Manning Road, Billerica, MA 01821
Diffuser bead support screen	Design per figure 6 Material: McMaster-Carr p/n 9358T131. Type 304 Stainless Steel Perforated Sheet 36 in. \times 40 in., 0625 in. Hole Dia, 23% Open Area, 22 Ga.	Custom fabrication
Diffuser bed beads	Diameter: 3 mm Material: glass	Fisher Scientific p/n 11-312A
Gasket, chimney-base	Buna-N Square O-Ring Cord Stock, $\frac{1}{8}$ in. Fractional Size	McMaster-Carr p/n 9700K121
Support plate legs (4) Connector screws, support plate-to-base (3)	Hex cap bolt, 1- $\frac{1}{4}$ in. $\frac{1}{2}$ -13 UNC $\frac{5}{16}$ -18 \times 4 in. hex cap bolts	Common Common
Support plate-to-base spacer sleeves	p/n M37 9 mm OD \times 89 mm Material: Brass Custom cut to finish	K & S ENGINEERING 6917 West 59th Street Chicago, IL 60638

Annex C Enclosure Integrity Procedure

This annex is not a part of the requirements of this NFPA document but is included for informational purposes only.

C.1 Procedure Fundamentals.

C.1.1 Scope.

C.1.1.1 This procedure outlines a method to equate enclosure leakage as determined by a door fan test procedure to worst-case clean agent leakage. The calculation method provided makes it possible to predict the time it will take for a descending interface to fall to a given height or, for the continually mixed cases, the time for the concentration to fall to a given percentage concentration.

C.1.1.2 Enclosure integrity testing is not intended to verify other aspects of clean agent system reliability, that is, hardware operability, agent mixing, hydraulic calculations, and piping integrity.

C.1.1.3 This procedure is limited to door fan technology and is not intended to preclude alternative technology such as acoustic sensors.

C.1.1.4 This procedure should not be considered to be an exact model of a discharge test. The complexity of this procedure should not obscure the fact that most failures to hold concentration are due to leaks in the lower surfaces of the enclosure, but the door fan does not differentiate between upper and lower leaks. The door fan provides a worst-case leakage estimate that is very useful for enclosures with complex hidden leaks, but it will generally require more sealing than is necessary to pass a discharge test.

C.1.2 Limitations and Assumptions.

C.1.2.1 Clean Agent System Enclosure. The following should be considered regarding the clean agent system and the enclosure:

- (1) *Clean Agent System Design.* This test procedure concerns only halon total flooding fire suppression systems using clean agent that are designed, installed, and maintained in accordance with this standard.
- (2) *Enclosure Construction.* Clean agent protected enclosures, absent of any containing barriers above the false ceiling, are not within the scope of Annex C.
- (3) *Clean Agent Concentration.* Special consideration should be given to clean agent systems with concentrations greater than 10 percent where the concern exists that high concentrations can result in significant overpressures from the discharge event in an enclosure with minimal leakage.
- (4) *Enclosure Height, H_0 .* This method is valid for any height enclosure, and no special considerations are needed.
- (5) *Static Pressures.* Wherever possible, static pressure differentials (HVAC system, elevator connections, etc.) across the enclosure envelope should be minimized during the door fan test. The test can only be relied on for enclosures having a range of static pressures outlined in C.2.5.2.3.

C.1.2.2 Door Fan Measurements. The following should be considered regarding the door fan and its associated measurements:

- (1) *Door Fan Standards.* Guidance regarding fan pressurization apparatus design, maintenance, and operation is provided by ASTM E 779 and CAN/CGSB-149.10-M86.

- (2) *Attached Volumes.* There can be no significant attached volumes within or adjoining the enclosure envelope that will allow detrimental clean agent leakage that would not be measured by the door fan. Such an attached volume would be significant if it is absent of any leakage except into the design envelope and is large enough to adversely affect the design concentration.
- (3) *Return Path.* All significant leaks must have an unrestricted return path to the door fan.
- (4) *Leak Location.* The difficulty in determining the specific leak location on the enclosure envelope boundaries using the door fan is accounted for by assuming clean agent leakage occurs through leaks at the worst location. This is when one-half of the total equivalent leakage area is assumed to be at the maximum enclosure height and the other half is at the lowest point in the enclosure. In cases where the below false ceiling leakage area (BCLA) is measured using C.2.6.2, the value attained for BCLA is assumed to exist entirely at the lowest point in the enclosure.
- (5) *Technical Judgment.* Enclosures with large overhead leaks but no significant leaks in the floor slab and walls will yield unrealistically short retention time predictions. Experience has shown that enclosures of this type can be capable of retaining clean agent for prolonged periods. However, in such cases the authority having jurisdiction might waive the quantitative results in favor of a detailed witnessed leak inspection of all floors and walls with a door fan and smoke pencil.

C.1.2.3 Retention Calculations. The following information in C.1.2.3.1 through C.1.2.3.10 should be considered regarding the retention calculations and its associated theory.

C.1.2.3.1 Dynamic Discharge Pressures. Losses due to the dynamic discharge pressures resulting from halon system actuation are not specifically addressed.

C.1.2.3.2 Static Pressure. Variable external static pressure differences (wind, etc.) are additive and should be considered.

C.1.2.3.3 Temperature Differences. When temperature differences exceeding 18°F (10°C) exist between the enclosure under test and the other side of the door fan, special considerations outlined in this document should be considered.

C.1.2.3.4 Floor Area. The floor area is assumed to be the volume divided by the maximum height of the protected enclosure.

C.1.2.3.5 Descending Interface. The enclosure integrity procedure assumes a sharp interface. When a clean agent is discharged, a uniform mixture occurs. As leakage takes place, air enters the room. This procedure assumes that the incoming air rides on top of the remaining mixture. In reality, the interface usually spreads because of diffusion and convection. These effects are not modeled because of their complexity. Where a wide interface is present, the descending interface is assumed to be the midpoint of a wide interface zone. Because of the conservatism built into the procedure, the effects of interface spreading can be ignored. If continual mechanical mixing occurs, a descending interface might not be formed (*see C.2.7.1.6*).

C.1.2.3.6 Leak Flow Characteristics. All leak flow is one-dimensional and does not take into account stream functions.

C.1.2.3.7 Leak Flow Direction. A particular leak area does not have bidirectional flow at any point in time. Flow through a leak area is either into or out of the enclosure.



C.1.2.3.8 Leak Discharge. The outflow from the leak discharges into an infinitely large space.

C.1.2.3.9 Leak Locations. Calculations are based on worst-case clean agent leak locations.

C.1.2.3.10 Clean Agent Delivery. The calculations assume that the design concentration of clean agent will be achieved. If a suspended ceiling exists, it is assumed that the clean agent discharge will not result in displacement of the ceiling tiles. Increased confidence can be obtained if ceiling tiles are clipped within 4 ft (1.2 m) of the nozzles and all perimeter tiles.

C.1.3 Definitions. For the purposes of Annex C, the following definitions are to apply.

C.1.3.1 Area, Effective Floor. The volume divided by the maximum halon protected height.

C.1.3.2 Area, Effective Flow. The area that results in the same flow area as the existing system of flow areas when it is subjected to the same pressure difference over the total system of flow paths.

C.1.3.3 Area, Equivalent Leakage (ELA). The total combined area of all leaks, cracks, joints, and porous surfaces that act as leakage paths through the enclosure envelope. This is represented as the theoretical area of a sharp-edged orifice that would exist if the flow into or out of the entire enclosure at a given pressure were to pass solely through it. For the purposes of this document, the ELA is calculated at the column pressure.

C.1.3.4 Area, Return Path. The effective flow area that the air being moved by the door fan must travel through to complete a return path back to the leak.

C.1.3.5 Attached Volumes. A space within or adjoining the enclosure envelope that is not protected by clean agent and cannot be provided with a clearly defined return path.

C.1.3.6 Blower. The component of the door fan used to move air.

C.1.3.7 Ceiling Slab. The boundary of the enclosure envelope at the highest elevation.

C.1.3.8 Column Pressure. The theoretical maximum positive pressure created at the floor slab by the column of the clean agent-air mixture.

C.1.3.9 Descending Interface. The enclosure integrity procedure assumes a sharp interface. When clean agent is discharged, a uniform mixture occurs. As leakage takes place, air enters the room. This procedure assumes that the incoming air rides on top of the remaining mixture. In reality, the interface usually spreads because of diffusion and convection. These effects are not modeled because of their complexity. Where a wide interface is present, the descending interface is assumed to be the midpoint of a wide interface zone. Because of the conservatism built into the procedure, the effects of interface spreading can be ignored. If continual mechanical mixing occurs, a descending interface might not be formed. (See C.2.7.1.6.)

C.1.3.10 Door Fan. The device used to pressurize or depressurize an enclosure envelope to determine its leakage characteristics. Also called the *fan pressurization apparatus*.

C.1.3.11 Enclosure. The volume being tested by the door fan. This includes the clean agent protected enclosure and any attached volumes.

C.1.3.12 Enclosure Envelope. The floor, walls, ceiling, or roof that together constitute the enclosure.

C.1.3.13 Enclosure, Protected. The volume protected by the clean agent extinguishing system.

C.1.3.14 Fan Pressurization Apparatus. The device used to pressurize or depressurize an enclosure envelope to determine its leakage characteristics. Also called the *door fan*.

C.1.3.15 Floor Slab. The boundary of the enclosure envelope at the lowest elevation.

C.1.3.16 Pressure Gauge, Flow. The component of the door fan used to measure the pressure difference across the blower to give a value used in calculating the flow into or out of the enclosure envelope.

C.1.3.17 Pressure Gauge, Room. The component of the door fan used to measure the pressure differential across the enclosure envelope.

C.1.3.18 Protected Height, Maximum. The design height of the clean agent column from the floor slab. This does not include the height of unprotected ceiling spaces.

C.1.3.19 Protected Height, Minimum. The minimum acceptable height from the floor slab to which the descending interface is allowed to fall during the retention time, as specified by the authority having jurisdiction.

C.1.3.20 Return Path. The path outside the enclosure envelope that allows air to travel to/from the leak to/from the door fan.

C.1.3.21 Static Pressure Difference. The pressure differential across the enclosure envelope not caused by the discharge process or by the weight of the clean agent. A positive static pressure difference indicates that the pressure inside the enclosure is greater than on the outside, that is, smoke would leave the enclosure at the enclosure boundary.

C.2 Test Procedure.

C.2.1 Preliminary Preparations. The individual(s) responsible for the protected enclosure should be contacted and the following preliminary steps should be taken:

- (1) Provide a description of the test
- (2) Advise the responsible individuals on time required for the test
- (3) Determine the staff needed (to control traffic flow, set HVAC, and so forth)
- (4) Determine the equipment required (for example, ladders)
- (5) Obtain a description of the HVAC system
- (6) Establish the existence of a false ceiling space and the size of ceiling tiles
- (7) Visually determine the readiness of the room with respect to the completion of obvious sealing
- (8) Determine if conflict with other building trades will occur
- (9) Determine the size of doorways
- (10) Determine the existence of adequate return path area outside the enclosure envelope used to accept or supply the door fan air

- (11) Evaluate other conflicting activities in and around space (for example, interruption to the facility being tested)
- (12) Obtain appropriate architectural HVAC and halon system design documents

C.2.2 Equipment Required. The following equipment is required to test an enclosure using fan pressurization technology.

C.2.2.1 Door Fan System.

C.2.2.1.1 The door fan(s) should have a total air flow capacity capable of producing a pressure difference at least equal to the predicted column pressure or 0.2 psi (10 Pa), whichever is greater.

C.2.2.1.2 The fan should have a variable speed control or a control damper in series with the fan.

C.2.2.1.3 The fan should be calibrated in air flow units or be connected to an airflow metering system.

C.2.2.1.4 The accuracy of air flow measurement should be ± 5 percent of the measured flow rate.

C.2.2.1.5 The room pressure gauge should be capable of measuring pressure differences from 0 psi (0 Pa) to at least 0.73 psi (50 Pa). It should have an accuracy of ± 1 Pa and divisions of 0.03 psi (2 Pa) or less. Inclined oil-filled manometers are considered to be traceable to a primary standard and need not be calibrated. All other pressure-measurement apparatus (for example, electronic transducer or magnehelic) should be calibrated at least yearly.

C.2.2.1.6 Door fan systems should be checked for calibration every 5 years under controlled conditions, and a certificate should be available for inspection at all integrity tests. The calibration should be performed according to manufacturer's specifications.

The certificate should include the following:

- (1) Description of calibration facility and responsible technician
- (2) Date of calibration and serial number of door fan
- (3) Room pressure gauge error estimates at 0.1 psi (8 Pa), 0.15 psi (10 Pa), 0.13 psi (12 Pa), 0.22 psi (15 Pa), 0.29 psi (20 Pa), and 0.6 psi (40 Pa) Pa measured by both ascending and descending pressures (minimum)
- (4) Fan calibration at a minimum of three leakage areas (approximate): 0.54 ft² (0.5 m²), 2.7 ft² (0.25 m²), and 0.54 ft² (0.05 m²) measured at a pressure of 0.15 psi (10 Pa).

C.2.2.1.7 A second blower or multiple blowers with flex duct and panel to flow to above-ceiling spaces is optional.

C.2.2.2 Accessories. The following equipment is also useful:

- (1) Smoke pencil, fully charged

CAUTION: Use of chemically generated smoke as a means of leak detection can result in activation of building or clean agent system smoke detectors. Appropriate precautions should be taken. Due to the corrosive nature of the smoke, it should be used sparingly.

- (2) Bright light source
- (3) Floor tile lifter
- (4) Measuring tape
- (5) Masking or duct tape
- (6) Test forms
- (7) Multi-tip screwdrivers
- (8) Shop knife or utility knife

- (9) Several sheets of thin plastic and cardboard
- (10) Door stops
- (11) Signs to post on doors that say "DO NOT SHUT DOOR — FAN TEST IN PROGRESS" or "DO NOT OPEN DOOR — FAN TEST IN PROGRESS"
- (12) Thermometer

C.2.2.3 Field Calibration Check.

C.2.2.3.1 This procedure enables the authority having jurisdiction to obtain an indication of the door fan and system calibration accuracy upon request.

C.2.2.3.2 The field calibration check should be done in a separate enclosure. Seal off any HVAC registers and grilles if present. Install the door fan per manufacturer's instructions and C.2.4. Determine if a static pressure exists using C.2.5.2. Check openings across the enclosure envelope for air flow with chemical smoke. If any appreciable flow or pressure exists, choose another room or eliminate the source.

C.2.2.3.3 Install a piece of rigid material less than 1/8 in. (3 mm) thickness (free of any penetrations) in an unused blower port or other convenient enclosure opening large enough to accept an approximately 155 in.² (0.1 m²) sharp-edged round or square opening.

C.2.2.3.4 Ensure that the door fan flow measurement system is turned to properly measure pressurization or depressurization and operate the blower to achieve a convenient pressure differential, preferably 0.15 psi (10 Pa).

C.2.2.3.5 At the pressure achieved, measure the flow and calibrate an initial ELA value using C.2.6.3. Repeat the ELA measurement under positive pressure and average the two results.

C.2.2.3.6 Create a sharp-edged round or square opening in the rigid material. The area of this opening should be at least 33 percent of the initial ELA measured. Typical opening sizes are approximately 77.5 in.², 155 in.², and 310 in.² (0.05 m², 0.1 m², and 0.2 m²), depending on the initial leakage of the enclosure. Adjust the blower to the previously used positive or negative pressure differential. Measure the flows and calculate an average ELA value using C.2.6.3.

C.2.2.3.7 Field calibration is acceptable if the difference between the first and second ELA value is within +15 percent of the hole area cut in the rigid material. If the difference in ELA values is greater than +15 percent, the door fan apparatus should be recalibrated according to the manufacturer's recommendations and either ASTM E 779 or CAN/CGSB-149.10-M86.

C.2.3 Initial Enclosure Evaluation.

C.2.3.1 Inspection.

C.2.3.1.1 Note the areas outside the enclosure envelope that will be used to supply or accept the door fan air.

C.2.3.1.2 Inspect all openable doors, hatches, and movable partitions for their ability to remain shut during the test.

C.2.3.1.3 Obtain or generate a sketch of the floor plan showing walls, doorways, and the rooms connected to the test space. Number or name each doorway.

C.2.3.1.4 Look for large attached volumes open to the test space via the floor or walls of the test space. Note volumes and apparent open connecting areas.



C.2.3.1.5 Check floor drains and sink drains for traps with liquid.

C.2.3.2 Measurement of Enclosure.

C.2.3.2.1 Measure the clean agent protected enclosure volume. Record all dimensions. Deduct the volume of large solid objects to obtain the net volume.

C.2.3.2.2 Measure the highest point in the clean agent protected enclosure.

C.2.3.2.3 Calculate the effective floor area by dividing the net clean agent protected volume by the maximum clean agent protected enclosure height.

C.2.3.3 Preparation.

C.2.3.3.1 Advise supervisory personnel in the area about the details of the test.

C.2.3.3.2 Remove papers and objects likely to be affected by the air currents from the discharge of the door fan.

C.2.3.3.3 Secure all doorways and openings as for a clean agent discharge. Post personnel to ensure they stay shut/open. Open doorways inside the protected enclosure even though they could be closed upon discharge.

C.2.3.3.4 Get the user's personnel and/or the clean agent contractor to set up the room in the same state as when a discharge would occur, that is, HVAC shut down, dampers closed, and so forth. Confirm that all dampers and closable openings are in the discharge-mode position.

C.2.4 Door Fan Installation.

C.2.4.1 The door fan apparatus generally consists of a single door fan. A double or multiple door fan for larger spaces or for neutralizing leakage through a suspended ceiling can be used for certain applications.

C.2.4.2 Set up one blower unit in the most convenient doorway leading into the space. Choose the doorway that opens into the largest return path area. Consideration should be given to individuals requiring access into or out of the facility.

C.2.4.3 Follow the manufacturer's instructions regarding setup.

C.2.4.4 Examine the sealing around the door (before door fan installation) that the door fan will be mounted in to determine if significant leakage exists. If significant leaks are found, they should be corrected. If the manufacturer's stated door fan sealing system leakage is less than the apparent remaining leakage of the doorway, the difference must be added to the leakage calculated in C.2.6 (see C.2.6.3.4).

C.2.4.5 Ensure that all pressure gauges are leveled and zeroed prior to connecting them to the fan apparatus. This should be done by first gently blowing into or drawing from the tubes leading to the pressure gauges so the needle fluid or readout moves through its entire span and stays at the maximum gauge reading for 10 seconds. This confirms proper gauge operation. If using a magnehelic gauge, gently tap the gauge face for 10 seconds. With both ports of each gauge on the same side of the doorway (using tubes if necessary), zero the gauges with their particular adjusting method.

C.2.4.6 Connect the tubing for the room pressure gauge. Ensure the tube is at the floor slab elevation and extends at least 10 ft (3 m) away from the outlet side of the door fan blower, away from its air stream path, and away from all signifi-

cant air streams (that is, HVAC air flows or openings where air flow could impinge on the tube).

C.2.4.7 The door fan should be arranged to alternately blow out of (depressurize) and blow into (pressurize) the space. Both measurements should be taken as described in C.2.6.

C.2.5 Door Fan Enclosure Evaluation.

C.2.5.1 Pressure Runup Inspection.

C.2.5.1.1 Activate the blower and adjust the enclosure pressure to -15 Pa (-218 psi) or maximum negative achievable [up to 15 Pa (218 psi)].

C.2.5.1.2 Inspect all dampers with smoke to ensure they are closing properly. Record problems and notify individuals responsible for the enclosure of the problems.

C.2.5.1.3 Inspect doors and hatches to ensure correct closure. Record problems and notify individuals responsible for the enclosure of the problems.

C.2.5.1.4 Inspect the wall perimeter (above and below the false floor) and the floor slab for major leaks. Note location and size of major leaks. Track down major air flow currents.

C.2.5.2 Static Pressure Measurement.

C.2.5.2.1 Seal the blower opening with the door fan properly installed, but without the blower operating. Observe the room pressure gauge for at least 30 seconds. Look for minor fluctuations in pressure.

C.2.5.2.2 Under discharge conditions, measure the worst-case (greatest) pressure differential (P_{SH}) across a section of envelope containing the largest quantity of leaks expected to leak clean agent. If the subfloor is pressurized at discharge, measure the differential between the subfloor and outside the envelope. Call this value P_{SH} (for static at discharge). Determine the flow direction with smoke or other indicating method.

C.2.5.2.3 If the static pressure (P_{ST}) has an absolute value greater than 25 percent of the column pressure calculated in C.2.6.1.3, it must be permanently reduced. Large static pressures decrease the level of certainty inherent in this procedure. The most common causes of excessive static pressure are leaky dampers, ducts, and failure to shut down air-handling equipment serving the enclosure.

C.2.5.2.4 Record the position of all doorways, whether open or shut, when the static pressure (P_{ST}) is measured.

C.2.6 Door Fan Measurement.

C.2.6.1 Total Enclosure Leakage Method.

C.2.6.1.1 This method determines the leakage of the entire enclosure envelope. It is determined by measuring the enclosure leakage under both positive and negative pressures and averaging the absolute values of the readings. This approach is used in order to minimize the influence of static pressures on the leakage calculation.

C.2.6.1.2 The procedures for determining the leakage of the entire enclosure envelope are as follows:

- (1) Block open all doorways around the enclosure and post personnel to ensure they stay open.
- (2) Ensure adequate return path area is provided to allow an unrestricted return air flow path back to the door fan from enclosure leaks.

- (3) Remove 1 percent of the floor tiles (for false floors) if an equivalent area is not already open.
- (4) If agent is designed to discharge above the false ceiling, remove 1 percent of the ceiling tiles.
- (5) Remeasure the static pressure (P_{ST}) at the time of the door fan test, between the room (not below the false floor) and the return path space.
- (6) Make every effort to reduce the static pressure (P_{bt}) by shutting down air-handling equipment even though it can operate during discharge. P_{bt} must be within a range of plus or minus 5 Pa where P_{bt} equals the bias pressure measured at the time of the test.
- (7) Record P_{ST} and determine its direction using smoke or other means.
- (8) Record the position of each doorway, open/shut.
- (9) If the static pressure fluctuates due to wind, use a wind-damping system incorporating four averaging tubes on each side of the building or electronic averaging to eliminate its effects. CAN/CGSB-149.10-M86 can be used.
- (10) If a subfloor pressurization air handler cannot be shut down for the test and leaks exist in the subfloor, these leaks cannot be accurately measured. Every attempt should be made to reduce subfloor leaks to insignificance. During the test, as many floor tiles as possible should be lifted to reduce the amount of subfloor pressurization. Note that under such conditions the suspended ceiling leakage neutralization method will be difficult to conduct due to massive air turbulence in the room.
- (11) If relief dampers are present, they should be blocked shut so they do not open during the door fan test. (At the completion of the test, the dampers must be unblocked.)

CAUTION: The removal of raised floor tiles creates a serious safety hazard. Appropriate precautions should be taken.

C.2.6.1.3 Calculate the column pressure in the clean agent protected enclosure using the following equation:

$$P_{mi} = (g_n)(H_o)(\rho_{mi} - \rho_a) \quad (\text{C.2.6.1.3})$$

where:

- P_{mi} = initial pressure due to the column (Pa)
- g_n = acceleration due to gravity (9.81 m/sec²)
- H_o = height of protected enclosure (m)
- ρ_{mi} = initial clean agent-air mixture density (kg/m³),
(see Equation C.2.7.1.4)
- ρ_a = air density (1.202 kg/m³)

If the calculated column pressure is less than 10 Pa, use 10 Pa as the column pressure.

C.2.6.1.4 Depressurize the enclosure with a door fan blower(s) until the measured pressure differential reading on the gauge (P_{1d}) is -10 Pa, where P_{1d} is the actual test pressure in Pa for the number one test point in the depressurization direction. If the static pressure (P_{ST}) was +1 Pa, and the calculated column pressure is 10 Pa, blow air out of the room until a P_m of +9 Pa is obtained. If using magnehelic gauges, tap both the room pressure and flow pressure gauges for 10 seconds each. Wait a further 30 seconds before taking the readings.

C.2.6.1.5 Measure the air flow Q_{1d} required to obtain -10 Pa, where Q_{1d} is the measured flow in m³/sec at P_{1d} .

C.2.6.1.6 Repeat C.2.6.1.4 and C.2.6.1.5 at a pressure of -50 Pa, (P_{2d}) and measure the flow (Q_{2d}), where P_{2d} is the actual test pressure in Pa for the number two test point in the depressuriza-

tion direction and Q_{2d} is the measured flow in m³/sec at P_{2d} . To reduce extrapolation errors, the ratio of $P_{2d}:P_{1d}$ must be at least 5:1. The ratio of $P_{1d}:P_c$ must be 5:1 or less. The ratio of the maximum peak pressure $P_{p/2}:P_{2d}$ must be 5:1 or more. P_{2d} can be higher than 50 Pa.

If the door fan is not capable of achieving a higher test pressure, P_2 of 50 Pa, then the test can be performed at 10 Pa only. In this case the exponent, n , must be set at 0.5 and can result in much more conservative retention times and venting areas.

C.2.6.1.7 Repeat the procedure in C.2.6.1.4 through C.2.6.1.6 while pressurizing the enclosure to +10 Pa P_{1p} and +50 Pa P_{2p} . Measure the air flow (Q_{1p} and Q_{2p}), where P_{1p} is the actual test pressure in Pa for the number one test point in the pressurization direction, P_{2p} is the actual test pressure in Pa for the number two test point in the pressurization direction, Q_{1p} is the measured flow in m³/sec at P_{1p} and Q_{2p} is the measured flow in m³/sec at P_{2p} . Each pressure must be within 5 percent of the corresponding depressurization pressure.

C.2.6.1.8 Ensure that the door fan flow measurement system is actually turned around between tests to properly measure pressurization or depressurization and that the motor rotation is not simply reversed. Ensure that the air flow entering the room is not deflected upward, which can cause lifting of any existing ceiling tiles.

C.2.6.1.9 Measure the air temperature within the enclosure (T_i) and outside the enclosure (T_o).

C.2.6.2 Suspended Ceiling Leakage Neutralization Method (Optional).

C.2.6.2.1 Where an unobstructed suspended ceiling exists, the leakage area below the ceiling can optionally be measured by neutralizing ceiling leaks. This method provides a more accurate estimate of leakage rates. This method should not be used if the walls between rooms within the zone are sealed at the ceiling slab. This method cannot be used when the system is designed to protect the area above this suspended ceiling. This test method does not imply that leakage above the suspended ceiling is acceptable. This technique can be difficult or impossible to perform under the following conditions:

- (1) Air movement within the room could make it difficult to observe neutralization, particularly in small rooms.
- (2) Obstructions above the suspended ceiling, that is, beams, ducts, and partitions, could make it difficult to obtain uniform neutralization.
- (3) Limited clearance above the suspended ceiling, for example, less than 1 ft (0.3 m), could make it difficult to obtain neutralization.

C.2.6.2.2 If not already done, obtain the leakage of the protected enclosure using the total enclosure leakage method in C.2.6.1.

C.2.6.2.3 Ceiling level supply registers and return grilles can be temporarily sealed off to increase the accuracy of this method. If such openings are sealed, P_{ST} should be remeasured.

Temporary sealing of such openings is not permitted when conducting a total enclosure leakage test.

C.2.6.2.4 Install two separate door fans or a multiple blower door fan with one blower ducted to the above suspended ceiling space and the other ducted into the room space below the



suspended ceiling. It is not necessary to measure air flow through the upper fan.

C.2.6.2.5 Depressurize above and below the suspended ceiling by adjusting two separate blowers until the required pressure reduction and suspended ceiling leak neutralization (that is, no air flow through the suspended ceiling) is achieved.

Leaks are neutralized when, at opened locations in the suspended ceiling, smoke does not move up or down when emitted within 1/4 in. (6 mm) of the openings. If neutralization is not possible at all locations, ensure that smoke either does not move, or moves down but not up. Choose undisturbed locations away from flex duct flows, airstreams, and lighting fixtures, because local air velocities make neutralization difficult to detect.

C.2.6.2.6 Measure the air flow (Q_{2f} and Q_{1p}) through the fan that is depressurizing the volume below the false ceiling to obtain the pressure (P_{1d} and P_{2d}).

C.2.6.2.7 Repeat the procedure in C.2.6.2.5 and C.2.6.2.6 while pressurizing the enclosure, except ensure that either smoke does not move or moves up but not down.

C.2.6.2.8 An alternate method for measuring the below-ceiling leaks consists of temporarily sealing identifiable ceiling level leaks using a flexible membrane, such as polyethylene sheet and tape, and then measuring the below-ceiling leakage solely using door fans drawing from the lower part of the room. No flex duct is needed. Examples of sealable leaks are undampened ceiling level supply registers or return grilles or an entire suspended ceiling lower surface.

C.2.6.3 Leakage Calculation.

C.2.6.3.1 Subsection C.2.6.3 outlines the door fan calculation to be used in conjunction with C.2.6.1 and C.2.6.2.

C.2.6.3.2 The air flow should be corrected for temperature if the difference between the temperature of the air being blown through the door fan and the temperature of the air going into or out of the leaks during the door fan test exceeds 18°F (10°C). If this condition exists, correct the flow as follows:

$$Q_c = Q_u \left(\frac{T_L + 273}{T_F + 273} \right)^{0.5} \quad (\text{C.2.6.3.2})$$

where:

Q_c = corrected flow (m³/sec)

Q_u = uncorrected flow (m³/sec)

T_L = temperature of air going through room leaks (°C)

T_F = temperature of air going through door fan (°C)

When depressurizing:

$$T_L = T_O$$

$$T_F = T_I$$

When pressurizing:

$$T_L = T_I$$

$$T_F = T_O$$

C.2.6.3.3 For Equation C.2.6.3.2, corrections for barometric pressure are not necessary because they cancel out, and corrections for humidity are too small to be of concern. No other corrections apply. If Equation C.2.6.3.2 is not used, then:

$$Q_c = Q_u \quad (\text{C.2.6.3.3})$$

C.2.6.3.4 Average absolute values of pressures at P_{1d} and P_{1p} to get P_I .

Average flow rates at Q_{1d} and Q_{1p} to get Q_I .

Average absolute values of pressures at P_{2d} and P_{2p} to get P_2 .

Average flow rates at Q_{2d} and Q_{2p} to get Q_2 .

Now the averaged flow rates Q_I at P_I and Q_2 at P_2 are curve fit as follows:

P_I is the uncorrected pressure difference across the enclosure in units of Pa for the lower (number one) test points.

P_2 is for the upper (number two) test points.

k_I is the constant used in the retention time formula for leaks in both directions.

It is the curve fit constant that defines flow in the enclosure at any pressure, P such that flow in m³/sec = $k_I \cdot P^n$

n is the average exponent for the leakage characteristic in both directions. It is the curve fit exponent that defines flow in the enclosure such that flow in m³/sec = $k_I \times P^n$

(Also see Equation C.2.6.3.4)

Determine the flow exponent using the equation:

$$n = \{[\ln(Q_1 \div Q_2)] \div [\ln(\Delta P_1 \div \Delta P_2)]\}$$

where Q_1 refers to the flow rate at P_1 (corresponding to the 50 Pa reading) and Q_2 refers to the flow rate at P_2 (corresponding to the 10 Pa reading).

n must be limited to range of 0.5 to 1.0.

Determine the flow constant, k_I using the equation:

$$k_I = Q_I \div P_I^n$$

$$A = \frac{1.271 Q_c}{\left(\frac{P_m}{\sqrt{P_m}} - \frac{P_{ST}}{\sqrt{P_{ST}}} \right)} \quad (\text{C.2.6.3.4})$$

The final value for A is determined by averaging the areas obtained under both a positive and negative pressure.

C.2.6.3.5 Equation C.2.6.3.4 should be used for both the total enclosure leakage method (see C.2.6.1) and the optional suspended ceiling leakage neutralization method (see C.2.6.2).

C.2.7 Retention Calculation.

C.2.7.1 Calculation.

C.2.7.1.1 Calculate the correlation constant k_2 using the following equation:

$$k_2 = k_1 \left(\frac{P_a}{2} \right)^n \quad (\text{C.2.7.1.1})$$

where:

k_2 = an intermediate calculation variable

C.2.7.1.2 Lower Leakage. If the leakage is measured using only C.2.6.1, total enclosure leakage method, then Equation C.2.7.1.2 should be used to calculate the lower leakage. If the below-ceiling leakage is measured using C.2.6.2, suspended ceiling leakage neutralization method, then k_1 applies instead. This equations is as follows:

$$k_1 (\text{lower leaks}) = \frac{k_1 (\text{total leaks})}{2} \quad (\text{C.2.7.1.2})$$

C.2.7.1.3 Leak Fraction. Determine the lower leak fraction (F_A) using the following equation:

$$F_A = k_1 \frac{k_l (\text{lower leaks})}{k_t (\text{total leaks})} \quad (\text{C.2.7.1.3a})$$

Where the lower leaks are measured using C.2.6.2, use the following equation:

$$F_A = \frac{k_l (\text{lower leaks}) 10^{(nl-nt)}}{k_t (\text{total leaks})} \quad (\text{C.2.7.1.3b})$$

where:

nl = the flow exponent n , for the lower leaks, as measured in C.2.6.3.5

nt = the flow exponent n , for the total leaks

C.2.7.1.4 Agent Mixture Density. Calculate the density of the agent-air mixture (r_m) using the following equation:

$$r_m = V_d \frac{C}{100} + \left[r_a \frac{(100-C)}{100} \right] \quad (\text{C.2.7.1.4})$$

where:

r_m = clean agent/air mixture density (kg/m^3)

r = air density ($1.202 \text{ kg}/\text{m}^3$)

C = clean agent concentration (% by volume)

V_d = agent vapor density at 21°C (kg/m^3)

FIC-131I: $8.051 \text{ kg}/\text{m}^3$ ($0.503 \text{ lb}/\text{ft}^3$)

FK-5-1-12: $13.66 \text{ kg}/\text{m}^3$ ($0.865 \text{ lb}/\text{ft}^3$)

HCFC Blend A: $3.84 \text{ kg}/\text{m}^3$ ($0.240 \text{ lb}/\text{ft}^3$)

HFC-124: $5.83 \text{ kg}/\text{m}^3$ ($0.364 \text{ lb}/\text{ft}^3$)

HFC-125: $5.06 \text{ kg}/\text{m}^3$ ($0.316 \text{ lb}/\text{ft}^3$)

HFC-227ea: $7.26 \text{ kg}/\text{m}^3$ ($0.453 \text{ lb}/\text{ft}^3$)

HFC-23: $2.915 \text{ kg}/\text{m}^3$ ($0.182 \text{ lb}/\text{ft}^3$)

IG-01: $1.70 \text{ kg}/\text{m}^3$ ($0.106 \text{ lb}/\text{ft}^3$)

IG-541: $1.41 \text{ kg}/\text{m}^3$ ($0.088 \text{ lb}/\text{ft}^3$)

IG-55: $1.41 \text{ kg}/\text{m}^3$ ($0.088 \text{ lb}/\text{ft}^3$)

C.2.7.1.5 Static Pressure. Determine the correct value for P_{bH} to be used in Equation C.2.7.1.7a, where P_{bH} is the bias pressure during the hold time. If the P_{bH} recorded is negative, let it equal the absolute value of P_{bH} and if it is positive, use the recorded value.

C.2.7.1.6 Minimum Height. Determine from the authority having jurisdiction the minimum height from the floor slab (H) that is not to be affected by the descending interface during the holding period.

C.2.7.1.7 Time. Calculate the minimum time (t) that the enclosure is expected to maintain the descending interface above (H), using the following equations:

Calculate the simplifying constant k_3 using the equations: For extinguishants heavier than air ($\rho_a < \rho_e$)

$$k_3 = \frac{2g_n (P_{mi} - P_a)}{P_{mi} + P_a \left(\frac{F}{1-F} \right)^{1/n}} \quad (\text{C.2.7.1.7a})$$

For extinguishants lighter than air ($\rho_a > \rho_e$) $F=0.5$

$$k_3 = \frac{2g_n |P_{mi} - P_n|}{P_{mi} + P_n \left(\frac{1-F}{F} \right)^{1/n}} \quad (\text{C.2.7.1.7b})$$

Calculate the simplifying constant k_4 using the equations: For extinguishants heavier than air ($\rho_a < \rho_e$)

$$k_4 = \frac{2P_{bh}}{P_{mi} + P_a \left(\frac{1-F}{F} \right)^{1/n}} \quad (\text{C.2.7.1.7c})$$

For extinguishants lighter than air ($\rho_a > \rho_e$) $F=0.5$

$$k_4 = \frac{2P_{bh}}{P_{mi} + P_a \left(\frac{1-F}{F} \right)^{1/n}} \quad (\text{C.2.7.1.7d})$$

For extinguishants heavier than air ($\rho_a < \rho_e$)

$$t = \frac{V}{H_0} \left(\frac{(k_3 H_0 + k_4)^{1-n} (k_3 H_e + k_4)^{1-n}}{(1-n) k_2 F k_3} \right) \quad (\text{C.2.7.1.7e})$$

For extinguishants lighter than air ($\rho_a > \rho_e$)

$$t = \frac{V}{H_0} \left(\frac{(k_3 H_0 + k_4)^{1-n} - (k_3 (H_0 - H_e) + k_4)^{1-n}}{(1-n) k_2 (1-F) k_3} \right) \quad (\text{C.2.7.1.7f})$$

where:

t = time (seconds)

k_3 = constant for equation simplification

k_4 = constant for equation simplification

g = acceleration due to gravity ($9.81 \text{ m}/\text{sec}^2$)

PSH = static pressure during discharge (P_a) (= P_{bh} in equations)

H_0 = height of the protected enclosure (m)

H_e = height of interface from floor (m). ("Protected Height, Minimum" per C.1.3.19 and C.1.2.3.5)

For extinguishants heavier than air ($\rho_a < \rho_e$)

$$t = \frac{V}{H_0} \left(\frac{(k_3 H_0 + k_4)^{1-n} - (k_3 H_e + k_4)^{1-n}}{(1-n) k_2 F k_3} \right) \quad (\text{C.2.7.1.7g})$$

For extinguishants lighter than air ($\rho_a > \rho_e$)

$$t = \frac{V}{H_0} \left(\frac{(k_3 H_0 + k_4)^{1-n} - (k_3 (H_0 - H_e) + k_4)^{1-n}}{(1-n) k_2 (1-F) k_3} \right) \quad (\text{C.2.7.1.7h})$$

For continual mixing, use the following equations:

For enclosures with continuous mixing, calculate the predicted hold time (t) for the agent concentration in the enclosure to fall from the initial concentration (c_i) to the concentration (c_{min}) using the equation:

For extinguishants heavier than air ($\rho_a < \rho_e$)

$$t = \frac{V}{F k_2} \int_{\rho_{mf}}^{\rho_{mi}} \left(\frac{2g_n H_0 (P_m - P_a)^{(n+1)/n} + 2P_{bh} (\rho_m - \rho_a)^{1/n}}{P_m + P_a \left(\frac{F}{1-F} \right)^{1/n}} \right)^{-n} d\rho_m \quad (\text{C.2.7.1.7i})$$

For extinguishants lighter than air ($\rho_a > \rho_e$)

$$t = \frac{V}{(1-F) k_2} \int_{\rho_{mi}}^{\rho_{mf}} \left(\frac{2g_n H_0 (P_a - P_m)^{(n+1)/n} + 2P_{bh} (\rho_a - \rho_m)^{1/n}}{P_m + P_a \left(\frac{1-F}{F} \right)^{1/n}} \right)^{-n} d\rho_m \quad (\text{C.2.7.1.7j})$$

where:

ρ_{mi} = initial clean agent-air mixture density (kg/m^3) at the initial concentration

ρ_{mf} = final clean agent-air mixture density (kg/m^3) at the minimum concentration



Solve the equation by a method of approximation, for example by using Simpson's Rule using an even number (not less than 20) of intervals.

C.2.7.2 Leakage area for visualization or relief vent calculation is found by the following equation:

$$\text{Leakage area} = 1.2.71 \cdot \rho^{n-0.5} \cdot k_1 \quad (\text{C.2.7.2})$$

Where the leakage area is in m^2 .

P is the pressure of interest.

n and k_1 are from C2.6.3.5.

Note: This leakage area is commonly referred to as the equivalent leakage area (ELA) and is equivalent to the flow that would be achieved through a thin flat plate with a discharge coefficient of 0.61 at the pressure, P .

C.2.7.3 Acceptance Criteria. The time (t) that was calculated in C.2.7.1.7 must equal or exceed the holding time period specified by the authority having jurisdiction.

C.2.8 Leakage Control.

C.2.8.1 Leakage Identification.

C.2.8.1.1 While the enclosure envelope is being pressurized or depressurized, a smoke pencil or other smoke source should be used to locate and identify leaks.

The smoke should not be produced by an open flame or any other source that is a potential source of fire ignition. Chemical smoke should be used only in small quantities, and consideration should be given to the corrosive nature of certain chemical smokes and their effects on the facility being tested.

C.2.8.1.2 Leakage identification should focus on obvious points of leakage, including wall to floor slab joint, wall to ceiling slab joint, penetrations of all kinds, HVAC ductwork, doors, and windows.

C.2.8.1.3 Alternate methods for leakage identification are available and should be considered. One method is the use of a directional acoustic sensor that can be selectively aimed at different sound sources. Highly sensitive acoustic sensors are available that can detect air as it flows through an opening. Openings can be effectively detected by placing an acoustic source on the other side of the barrier and searching for acoustic transmission independent of fan pressurization or depressurization. Another alternative is to use an infrared scanning device if temperature differences across the boundary are sufficient.

C.2.8.2 Leakage Alteration.

C.2.8.2.1 Procedure.

C.2.8.2.1.1 Protected areas should be enclosed with wall partitions that extend from the floor slab to ceiling slab or floor slab to roof.

C.2.8.2.1.2 If a raised floor continues out of the protected area into adjoining rooms, partitions should be installed under the floor directly under above-floor border partitions. These partitions should be caulked top and bottom. If the adjoining rooms share the same under-floor air handlers, then the partitions should have dampers installed in the same manner as is required for ductwork.

C.2.8.2.1.3 Any holes, cracks, or penetrations leading into or out of the protected area should be sealed. This includes pipe chases and wire troughs. All walls should be caulked around

the inside perimeter of the room where the walls rest on the floor slab and where the walls intersect with the ceiling slab or roof above.

C.2.8.2.1.4 Porous block walls should be sealed slab-to-slab to prevent gas from passing through the block. Multiple coats of paint could be required.

C.2.8.2.1.5 All doors should have door sweeps or drop seals on the bottoms, and weather stripping around the jambs, latching mechanisms, and door closer hardware. In addition, double doors should have a weather-stripped astragal to prevent leakage between doors and a coordinator to ensure proper sequence of closure.

C.2.8.2.1.6 Windows should have solid weather stripping around all joints.

C.2.8.2.1.7 All unused and out-of-service ductwork leading into or from a protected area should be permanently sealed off (airtight) with metal plates caulked and screwed in place. Ductwork still in service with the building air-handling unit should have butterfly blade-type dampers installed with neoprene seals. Dampers should be spring-loaded or motor-operated to provide 100 percent air shutoff. Alterations to air conditioning, heating, ventilating ductwork, and related equipment should be in accordance with NFPA 90A or NFPA 90B, as applicable.

C.2.8.2.1.8 All floor drains should have traps, and the traps should be designed to have water or other compatible liquid in them at all times.

C.2.8.2.2 Materials.

C.2.8.2.2.1 All materials used in altering leaks on enclosure envelope boundaries, including walls, floors, partitions, finish, acoustical treatment, raised floors, suspended ceilings, and other construction, should have a flame spread rating that is compatible with the flame spread requirements of the enclosure.

C.2.8.2.2.2 Exposed cellular plastics should not be used for altering leakage unless considered acceptable by the authority having jurisdiction.

C.2.8.2.2.3 Cable openings or other penetrations into the enclosure envelope should be firestopped with material that is compatible with the fire rating of the barrier.

C.2.9 Test Report. Upon completion of a door fan test, a written test report should be prepared for the authority having jurisdiction and made part of the permanent record. The test report should include the following:

- (1) Date, time, and location of test
- (2) Names of witnesses to the test
- (3) Room dimensions and volume
- (4) All data generated during test, including computer printouts
- (5) Descriptions of any special techniques utilized by test technician (that is, use of optional ceiling neutralization and temporary sealing of suspended ceiling)
- (6) In case of technical judgment, a full explanation and documentation of the judgment
- (7) Test equipment make, model, and serial number
- (8) Copy of current calibration certificate of test equipment
- (9) Name and affiliation of testing technician and signature

Annex D Enclosure Evaluation

This annex is not a part of the requirements of this NFPA document but is included for informational purposes only.

D.1 The discharge of a clean agent total flooding fire extinguishing system into a protected enclosure creates pressure fluctuations therein. Normally, for halocarbon agents, the enclosure will have enough vent area and resistive strength to moderate and resist the pressure changes so that no damage occurs. In some circumstances, however, the enclosure could be damaged by the momentary pressure change. Damaging pressure can develop if there is insufficient vent area provided by normal leakage in the enclosure boundary. Alternatively, enclosure damage might occur due to a relatively weak construction, perhaps due to design or fabrication deficiencies. Damage could occur due to a combination of these factors.

The peak pressure created in an enclosure depends on many factors, including the agent concentration and discharge time, humidity, opening characteristics of the system discharge valve, and the aggregate vent area of the enclosure. The most influential parameter is the aggregate vent area, which is comprised of all openings whether unintentional or intentional

Pressures are developed within an enclosure during the discharge of both inert and halocarbon clean agents. The discharge of an inert agent results in only a positive pressure change, as illustrated by Figure D.1(a).

On the other hand, the discharge of a halocarbon agent usually creates an initially negative pressure change followed by a positive pressure change, as illustrated by Figure D.1(b)

Figure D.1(b) shows the measured pressure changes within an enclosure during an actual discharge of halocarbon clean agent. The measured pressure within the enclosure initially dropped to a negative peak value of -387 Pa (8.1 pounds per square foot), then rose to the positive peak value of $+671$ Pa (14.0 pounds per square foot) before falling back down to 0, about 10 seconds after the end of the 5.5 second discharge.

Enclosures must be capable of withstanding peak pressures, whether positive in the case of the inert agents or both negative and positive in the case of the halocarbon agents. To achieve this objective, it is necessary to determine the strength of the enclosure's bounding walls, floor, and ceiling in terms of their ability to resist pressure decreases and increases as applicable to the specific agent.

The strength of the enclosure walls and ceiling usually determine the overall strength of an enclosure. The strength of the construction elements and their physical dimensions play an important role. For example, a common wall construction system consists of gypsum wallboard attached to vertical studs of either metal or wood. The inherent strength of the stud system will dictate the overall strength of the wall. The stud material, physical dimensions, and spacing between studs have a significant influence on the overall strength of the stud system.

Annex E Informational References

E.1 Referenced Publications. The documents or portions thereof listed in this annex are referenced within the informational sections of this standard and are not part of the requirements of this document unless also listed in Chapter 2 for other reasons.

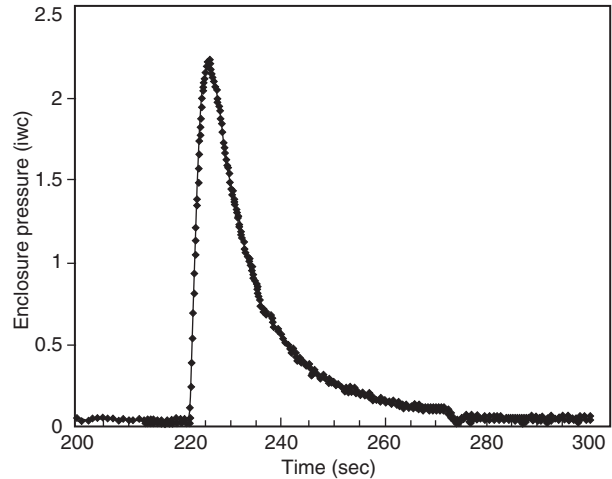

FIGURE D.1(a) Example of an Actual IG-541 60 Second Discharge Showing Peak Pressure.

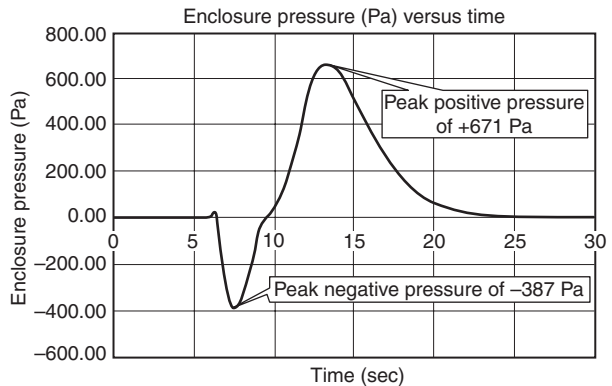

FIGURE D.1(b) Example of an Actual HFC-227ea Discharge Showing Peak Pressures.

E.1.1 NFPA Publications. National Fire Protection Association, 1 Batterymarch Park, Quincy, MA 02169-7471.

NFPA 12A, *Standard on Halon 1301 Fire Extinguishing Systems*, 2004 edition.

NFPA 70, *National Electrical Code*[®], 2008 edition.

NFPA 72[®], *National Fire Alarm Code*[®], 2007 edition.

NFPA 77, *Recommended Practice on Static Electricity*, 2007 edition.

NFPA 90A, *Standard for the Installation of Air-Conditioning and Ventilating Systems*, 2002 edition.

NFPA 90B, *Standard for the Installation of Warm Air Heating and Air-Conditioning Systems*, 2006 edition.

E.1.2 Other Publications.

E.1.2.1 ASHRAE Publications. American Society of Heating, Refrigerating and Air Conditioning Engineers, Inc., 1791 Tullie Circle, N.E., Atlanta, GA 30329-2305.

ANSI/ASHRAE 34, *Number Designation and Safety Classification of Refrigerants*, 1992.

E.1.2.2 ASME Publications. American Society of Mechanical Engineers, Three Park Avenue, New York, NY 10016-5990.

ASME B31.1, *Power Piping Code*, 1998, including B31.1a 1999 Addenda and B31.1b 2000 Addenda.

E.1.2.3 ASTM Publications. ASTM International, 100 Barr Harbor Drive, P.O. Box C700, West Conshohocken, PA 19428-2959.

ASTM A 106, *Standard Specification for Seamless Carbon Steel Pipe for High-Temperature Service*, 1994.

ASTM E 176, *Terminology of Fire Standards*, 2004.

ASTM E 177, *Standard Practice for Use of the Terms Precision and Bias in ASTM Test Methods*.

ASTM E 456, *Standard Terminology for Relating to Quality and Statistics*.

ASTM E 691, *Standard Practice for Conducting an Interlaboratory Study to Determine the Precision of a Test Method*.

ASTM E 779, *Standard Test Method for Determining Air Leakage Rate by Fan Pressurization*, 1987.

ASTM E 1354, *Standard Test Method for Heat and Visible Smoke Release Rates for Materials and Products Using an Oxygen Consumption Calorimeter*, 1999.

ASTM F 1387, *Standard Specification for Performance of Mechanically Attached Fittings*, 1993.

E.1.2.4 CGA Publications. Compressed Gas Association, 4221 Walney Road, 5th Floor, Chantilly, VA 20151-2923, Phone (703) 788-2700.

CGA C-6, *Standard for Visual Inspection of Steel Compressed Gas Cylinders*, 1993.

E.1.2.5 CSA Publications. Canadian Standards Association, 5000 Spectrum Way, Suite 160, Mississauga, Ontario L4W 5N6, Canada.

CAN/CGSB-149.10-M86, *Determination of the Airtightness of Building Envelopes by the Fan Depressurization Method*.

E.1.2.6 FSSA Publications. Fire Suppression Systems Association, 5024-R Campbell Boulevard, Baltimore, MD 21236-5974, (www.FSSA.Net).

FSSA *Pipe Design Handbook for Use with Special Hazard Fire Suppression Systems*, 1st ed., June 2001.

E.1.2.7 IMO Publications. International Maritime Organization, 4 Albert Embankment, London, SE1 7SR United Kingdom.

International Convention for the Safety of Life at Sea, (SOLAS), 1974.

SOLAS Regulation II-2/Regulation 5.2, Carbon Dioxide Systems, 1997.

SOLAS Regulation II-2/Regulation 5.3, Halogenated Hydrocarbon Systems, 1997.

E.1.2.8 ISO Publications. International Organization for Standardization, 1 ch. de la Voie-Creuse, Case postale 56, CH-1211 Geneva 20, Switzerland.

ISO 14520, *Gaseous fire-extinguishing systems — Physical properties and system design — Part 1: General requirements* (2000).

E.1.2.9 UL Publications. Underwriters Laboratories Inc., 333 Pfingsten Road, Northbrook, IL 60062-2096.

UL-2166, *Standard for Halocarbon Clean Agent Extinguishing System Units* (31 March 1999).

UL-2127, *Standard for Inert Gas Clean Agent Extinguishing System Units* (31 March 1999).

E.1.2.10 U.S. Government Publications. U.S. Government Printing Office, Washington, DC 20402.

Title 49, Code of Federal Regulations, Part 111.59, Subchapter J.

Federal Register, Volume 59, Page 13044, EPA SNAP Program.

E.1.3 Other References.

Bayless, H., and Niemann, R., "Update on the Evaluation of Selected NFPA 2001 Agents for Suppressing Class 'C' Energized Fires," *Proceedings*, Halon Options Technical Working Conference, Albuquerque, NM, pp. 293-294, 1998.

Bengtson, G., Niemann, R., "Update in the Evaluation of Selected NFPA 2001 Agents for Suppressing Class C Energized Fires," *Proceedings*, Halon Options Technical Working Conference, Albuquerque, NM, May 24-26, 2005.

Cholin, R. R., "Testing the Performance of Halon 1301 on Real Computer Installations," *Fire Journal*, Sept. 1972.

Coll, John P., Fenwal, CRC Report No. PSR-661, "Inerting Characteristics of Halon 1301 and 1211 Using Various Combustibles," August 16, 1976.

Cotton, F. A., and G. Wilkinson, *Advanced Inorganic Chemistry*, John Wiley & Sons, New York, 1980, p. 364.

Dalby, W., Evaluation of the toxicity of hydrogen fluoride at short exposure times. Stonybrook Laboratories, Inc., 311 Pennington-Rocky Hill Road, Pennington, NJ, sponsored by the Petroleum Environmental Research Forum (PERF), PERF Project No. 92-90, 1996.

Dalzell, Warner, Fenwal, CRC Report No. PSR-624, "A Determination of the Flammability Envelope of Four Ternary Fuel-Air-Halon 1301 Systems," October 7, 1975.

DiNunno, P. J., *Engineering Evaluation and Comparison of Halon Alternatives and Replacements*, 1993 International CFC & Halon Alternatives Conference, Washington, DC, 1993.

DiNunno, P. J., E. W. Forsell, M. J. Ferreria, C. P. Hanauska, and B. A. Johnson, "Modeling of the Flow Properties and Discharge of Halon Replacement Agents," *Process Safety Progress*, Vol. 14, No. 1, January 1995.

Driscoll, M., Rivers, P., 3M, "Clean Extinguishing Agents and Continuously Energized Circuits: Recent Findings," *Proceedings*, Halon Options Technical Working Conference, Albuquerque, NM, pp. 129-140, 1997.

DuPont. Acute inhalation of hydrogen fluoride in rats. Haskell Laboratory Report HLR 365-90, 1990.

Elliot, D. G., P. W. Garrison, G. A. Klein, K. M. Moran, and M. P. Zydowicz, "Flow of Nitrogen-Pressurized Halon 1301 in Fire Extinguishing Systems," *JPL Publication 84-62*, Jet Propulsion Laboratory, Pasadena, CA, November 1984.

Fernandez, R., "DuPont's Alternatives to Halon 1301 and 1211, Recent Findings," *Proceedings of the Halon Technical Working Conference*, April 30-May 1, 1991, Albuquerque, NM.

Ford, C. L., *Halon 1301 Computer Fire Test Program: Interim Report*, 1972.

HT Research Institute, 1973.

Hanauska, C., "Perfluorocarbons as Halon Replacement Candidates," *Proceedings of the Halon Technical Working Conference*, April 30-May 1, 1991, Albuquerque, NM.

Hesson, J. C., "Pressure Drop for Two Phase Carbon Dioxide Flowing in Pipe Lines," Master of Science Thesis in CHE. Illinois Institute of Technology, Jan. 1953.

Hughes Associates, Inc., *Hazard Assessment of Thermal Decomposition Products of FM-200™ in Electronics and Data Processing Facilities*, Hughes Associates, 1995.

Largent, E. J., The metabolism of fluorides in man. *Arch Ind. Health* 21:318-323, 1960.

Machle, W., and K. R. Kitzmiller, The effects of the inhalation of hydrogen fluoride. II. The response following exposure to low concentrations. *J. Ind. Hyg. Toxicol.* 17:223-229, 1935.

Machle, W., F. Tharnann, K. R. Kitzmiller, and J. Cholak, The effects of the inhalation of hydrogen fluoride. I. The response following exposure to high concentrations. *J. Ind. Hyg. Toxicol.* 16:129-145, 1934.

Meacham, B. J., *Fire Technology*, First Quarter, 1993, 35.

Meldrum, M. *Toxicology of Substances in Relation to Major Hazards: Hydrogen Fluoride*. Health and Safety Executive (HSE) Information Centre, Sheffield S37HQ, England, 1993.

NIST 1998.

Naval Research Laboratory Report Ser 6180/0049.2 of 26 January 1995, "Agent Concentration Inhomogeneities in Real Scale Halon Replacement."

Niemann, R., Bayless, H., and Craft, C., "Evaluation of Selected NFPA 2001 Agents for Suppressing Class 'C' Energized Fires," *Proceedings*, Halon Options Technical Working Conference, Albuquerque, NM, pp. 399-412, 1996.

Peatross, M. J., and E. W. Forssell, *A Comparison of Thermal Decomposition Product Testing of Halon 1301 Alternative Agents*, 1996 Halon Options Technical Working Conference, Albuquerque, NM, 1996.

Pedley, M. D., *Corrosion of Typical Orbiter Electronic Components Exposed to Halon 1301 Pyrolysis Products*, NASA TR-339-001, 1995.

Robin, M. L., "Evaluation of Halon Alternatives," *Proceedings of the Halon Technical Working Conference*, April 30-May 1, 1991, Albuquerque, NM, p. 16.

Sax, N. I., *Dangerous Properties of Industrial Materials*, 6th ed., Van Nostrand Reinhold, New York, 1984.

Senecal, Joseph A., Fenwal Safety Systems CRC Technical Note No. 361, Agent Inerting Concentrations for Fuel-Air Systems, May 27, 1992.

Senecal, J.A., "Flame Extinguishing by Inert Gases: Theoretical & Experimental Analysis" Central States Section/The Combustion Institute Meeting, March 2004.

Sheinson et al., R. S., *J. Fire & Flamm.*, 12, 229, 1981.

Sheinson, R. S., "Halon Alternatives — Compartment Total Flooding Testing," *Proceedings of the International Conference on CFC and Halon Alternatives*, December 3-5, 1991, Baltimore, MD, 1991, p. 629.

Sheinson, Ronald S., Harold G. Eaton, Bruce Black, Roger Brown, Howard Burchell, Alexander Maranghides, Clark Mitchell, Glen Salmon, and Walter D. Smith, "Halon 1301 Total Flooding Fire Testing, Intermediate Scale," *Proceedings Halon Alternatives Technical Working Conference*, May 3-5, 1994, Albuquerque, NM.

Sheinson, Ronald S., Alexander Maranghides, Harold G. Eaton, Doug Baryliski, Bruce H. Black, Roger Brown, Howard Burchell, Peter Byne, Tom Friderichs, Clark Mitchell, Michelle Peatross, Glen Salmon, Walter D. Smith, and Frederick W. William, "Large Scale (840M3) Total Flooding Fire Extinguishment Results," *Proceedings Halon Alternatives Technical Working Conference*, May 1995, Albuquerque, NM.

Skaggs, S. R., and T. Moore, *Toxicological Properties of Halon Replacements*, 208th ACS National Meeting, Washington, DC, 1994; S.R. Skaggs and T. Moore, *Toxicology of Halogenated Halon Substitutes*, Fire Safety Without Halon Conference, Zurich, Switzerland, September 1994.

Western Fire Center, Kelso, WA.

Wysocki, T. J., "Single Point Flow Calculations for Liquefied Compressed Gas Fire Extinguishing Agents," Halon Options Technical Working Conference Proceedings, Albuquerque, NM, 1996.

Wysocki, T. J., and B. C. Christensen, "Inert Gas Fire Suppression Systems Using IG541 (Inergen) Solving the Hydraulic Calculation Problem," Halon Options Technical Working Conference Proceedings, Albuquerque, NM, 1996.

E.2 Informational References. *The following documents or portions thereof are listed here as informational resources only. They are not a part of the requirements of this document.*

ASME/ANSI B31, *Code for Pressure Piping*, 1992.

ASTM A 53, *Standard Specification for Pipe, Steel, Black and Hot-Dipped, Zinc-Coated Welded and Seamless*, 1994.

ASTMA 120, *Specification for Welded and Seamless Steel Pipe*, 1984.

DiNunno, P. J., and E. K. Budnick, "A Review of Discharge Testing of Halon 1301 Total Flooding Systems," National Fire Protection Research Foundation, Quincy, MA, 1988.

DiNunno, P. J., and E. W. Forssell, et al., "Evaluation of Halon 1301 Test Gas Simulants," *Fire Technology*, 25 (1), 1989.

DiNunno, P. J., and E. W. Forssell, et al., "Hydraulic Performance Tests of Halon 1301 Test Gas Simulants," *Fire Technology*, 26 (2), May 1990, pp. 121-140.

Fellows, B. R., R. G. Richard, and I. R. Shankland, "Electrical Characterization of Alternative Refrigerants," XVIII International Congress of Refrigeration, August 10-17, 1991.

Ferreira, M. J., C. P. Hanauska, and M. T. Pike, "Thermal Decomposition Products Results Utilizing PFC-410 (3M Brand PFC 410 Clean Extinguishing Agent)," 1992 Halon Alternatives Working Conference, Albuquerque, NM, May 12-14, 1992.

Ferreira, M. J., J. A. Pignato, and M. T. Pike, "An Update on Thermal Decomposition Product Results Utilizing PFC-410," 1992, International CFC and Halon Alternative Conference, Washington, DC, October 1, 1992.

Hirt, C. W., and N. C. Romero, "Application of a Drift-Flux Model to Flashing in Straight Pipes," Los Alamos Scientific Laboratory, Los Alamos, NM, 1976.

Lambertsen, C. J., "Research Bases for Improvements of Human Tolerance to Hypoxic Atmospheres in Fire Prevention and Extinguishment," Institute for Environmental Medicine, University of Pennsylvania, October 30, 1992.

Lambertsen, C. J., "Short Duration INERGEN Exposures, Relative to Cardiovascular or Pulmonary Abnormality," Institute for Environmental Medicine, University of Pennsylvania, February 1, 1993.

Nicholas, J. S., and S. W. Hansen, "Summary of the Physiology of INERGEN," Ansil Fire Protection, April 1, 1993.

Robin, M. L., "Halon Alternatives: Recent Technical Progress," 1992 Halon Alternatives Working Conference, Albuquerque, NM, May 12-14, 1992.

Skaggs, S. R., R. E. Tapscott, and T. A. Moore, "Technical Assessment for the SNAP Program," 1992 Halon Alternatives Working Conference, Albuquerque, NM, May 12-14, 1992.

Tamanini, F. "Determination of Inerting Requirements for Methane/Air and Propane/Air Mixtures by an Ansil Inerting Mixture of Argon, Carbon Dioxide and Nitrogen," Factory Mutual Research, August 24, 1992.

United Nations Environment Programme, Montreal Protocol on Substances that Deplete the Ozone Layer — Final Act 1987, UNEP/RONA, Room DCZ-0803, United Nations, New York, NY, 10017.

E.3 References for Extracts in Informational Sections. (Reserved).



Index

Copyright © 2007 National Fire Protection Association. All Rights Reserved.

The copyright in this index is separate and distinct from the copyright in the document that it indexes. The licensing provisions set forth for the document are not applicable to this index. This index may not be reproduced in whole or in part by any means without the express written permission of NFPA.

-A-

- Abort switches** 4.3.5.3, 7.7.2.4.13, 7.7.2.5.2(4), A.4.3.5.3
- Acceptance, installation** 7.7.2, A.7.7.2.2.10 to A.7.7.2.3
- Accidental discharge** *see* Unwanted system operation
- Actuation systems** 4.3.1, 4.3.3, 7.7.2.4.4, 7.7.2.4.10, 7.7.2.4.11, 7.7.2.4.13, A.4.3.3.5.1, A.5.5.3.3
 - Functional tests 7.7.2.5.2(3)
 - Marine systems 8.5, A.8.5.1.2, A.8.5.2.3
- Adjusted minimum design quantity (AMDQ) (definition)** 3.3.1
- Agent concentration**
 - Definition 3.3.2
 - Design concentration requirements 5.4
 - Cup burner method for determining agent concentration 5.4.2.1, A.5.4.2, Annex B
 - Marine systems 8.8, A.8.8.4, A.8.8.5
 - Sea level equivalent of agent (definition) 3.3.27
- Alarm systems** 4.3.1, 7.7.2.4.4 to 7.7.2.4.6, A.1.5.1.4.1
 - Equipment failure 4.3.5.4
 - Functional tests 7.7.2.5.1 to 7.7.2.5.3
 - Hazardous atmosphere A.1.5.1.4.1
 - Marine systems protecting Class B hazards 8.6.1, 8.6.2, 8.6.5, A.8.6.2, A.8.6.5
 - Operating alarms 4.3.5, A.4.3.5.3
 - Pre-discharge alarm and time delays 1.5.1.4.1, 1.5.1.4.3, 1.5.1.4.4, 4.3.5.6, A.1.5.1.2, A.1.5.1.4.4, A.4.3.5.6.1
 - Working plans 5.1.2.2(18), 5.1.2.2(20), 5.1.2.2(26)
- Application, rate of** 5.7.1, A.5.7.1.2
- Approved/approval**
 - Definition 3.2.1, A.3.2.1
 - Of installations 7.7, A.7.7.2.2.10 to A.7.7.2.3
 - Marine systems 8.12
- Area**
 - Effective floor (definition) C.1.3.1
 - Effective flow (definition) C.1.3.2
 - Effective leakage (ELA) *see* Equivalent leakage area (ELA)
 - Return path (definition) C.1.3.4
- Argon (IG-01)** A.1.4.1.2, Fig. A.4.1.4.1(j)
 - Physical properties Table A.1.4.1(b), Table A.1.4.1(d)
 - Total flooding quantity Table A.5.5.2(a), Table A.5.5.2(b)
- Argon–nitrogen–carbon dioxide blend** *see* IG-541
- Argon–nitrogen inerting blend** *see* IG-55
- Attached volumes**
 - Definition C.1.3.5
 - Door fan measurements C.1.2.2
- Authority having jurisdiction (definition)** 3.2.2, A.3.2.2
- Auto-ignition point, fuel with** 6.4.3.3, A.6.4.3.3

-B-

- Blower** 7.7.2.3
 - Definition C.1.3.6

-C-

- Canadian Transport Commission, regulations** 4.1.4.3, 7.2.1, A.7.2.1
- Carbon dioxide, as inerting agent** A.1.4.1.2
- Carbon dioxide–nitrogen–argon dioxide blend** *see* IG-541
- Cast-iron pipe and fittings** 4.2.1.2, 4.2.3.2
- Ceiling slab (definition)** C.1.3.7
- Chemical fires, use on** 1.4.2.2, A.1.4.2.2
- Class A fire**
 - Definition 3.3.3
 - Flame extinguishment concentrations ... 5.4.2.2, 5.4.2.4, A.5.4.2.2, Table A.5.4.2.2(b), A.5.4.2.4

Class B fire

- Definition 3.3.4
- Flame extinguishment concentrations 5.4.2.1, 5.4.2.3, 8.8.3, A.5.4.2, Annex B
- Local application systems for 6.1.1, 6.4.1.3, 6.4.3.3, A.6.4.1.3, A.6.4.3.3

Class B hazards

- Design factor for enclosure pressure A.5.5.3.3
- Greater than 6000 ft³, marine systems protecting 8.6, A.8.6.1 to A.8.6.6

Class C fire

- Definition 3.3.5
- Flame extinguishment concentrations 5.4.2.5, A.5.4.2.5.2

Clean agents *see also* Agent concentration

- Applicability 1.4.1, A.1.4.1
- Compatibility with other agents 1.8, A.1.8.1
- Decomposition of 1.4.2.4, 8.2.3, A.1.4.2.4, A.1.5.1.1 to A.1.5.1.3
- Definition 3.3.6
- Mixture density calculation C.2.7.1.4
- Quality 4.1.2, A.4.1.2
- Quantity 4.1.1, 5.1.2.2(26), 7.1.3, 7.1.5, 7.7.2.2.11, A.4.1.1.2
- Recycling or disposal of 7.1.4, 7.1.5, A.4.1.2, A.7.1.4
- Retrofitability 1.7
- Supply 4.1, A.4.1.1.2 to A.4.1.4.5(2)
 - Marine systems 8.4

Clearances (electrical) 1.5.2, 8.3.2, A.8.3.2

- Definition 3.3.7

Column pressure

- Calculation C.2.6.1.3
- Definition C.1.3.8

Compatibility of clean agents 1.8, A.1.8.1**Components** Chap. 4**Conductors, ungrounded, electrostatic charging of** A.1.4.2.2**Containers**

- Arrangement 4.1.3, A.4.1.3.2
 - Marine systems 8.4.2, A.8.4.2
 - Characteristics 4.1.4, A.4.1.4.1 to A.4.1.4.5(2)
 - Functional tests 7.7.2.5.1(2)
 - Inspection, testing, and maintenance 7.1.3 to 7.1.6, 7.2, 7.7.2.2.8, 7.7.2.2.9, A.7.2.1, A.7.2.2
 - Marine systems 8.4.2 to 8.4.5, A.8.4.2
 - Nonrefillable 7.1.5
 - Pressure 8.4.2.1; *see also* Pressurization levels
 - Refillable 4.1.4.4, 7.1.3, 7.1.4, 8.11.2, 8.11.3.1, A.7.1.4
 - Working plans 5.1.2.2(12), 5.1.2.2(18), 5.1.2.2(22)
- Control rooms and electronic equipment spaces (marine)** A.8.2.1
- Definition 3.3.8
- Control systems** 4.3.1, 4.3.4, 7.7.2.4.4, 7.7.2.4.14
- Marine systems 8.5, A.8.5.1.2, A.8.5.2.3
 - Primary power source, testing of 7.7.2.5.4
 - Working plans 5.1.2.2(18)
- Cylinders**
- Safe handling procedures 1.5.1.5.1, 1.5.1.5.2
 - Stored, protection for 8.6, A.8.6.1 to A.8.6.6

-D-

- Decomposition, clean agents** 1.4.2.4, 8.2.3, A.1.4.2.4, A.1.5.1.1 to A.1.5.1.3, A.5.5.3.3, A.5.7.1.2

Definitions Chap. 3, C.1.3

Descending interface	
Definition	C.1.3.9
Minimum time calculation	C.2.7.1.7
Retention calculations	C.1.2.3.5
Design concentration requirements	5.4, A.5.4.3
Marine systems	8.8, A.8.8.4, A.8.8.5
Working plans	5.1.2.2(8)
Design factor (DF) (definition)	3.3.9
Design quantity	5.5, A.5.5.1 to A.5.5.3
Adjusted minimum design quantity (AMDQ) (definition)	3.3.1
Final design quantity (FDQ) (definition)	3.3.12
Marine systems	8.8.4, A.8.8.4
Minimum design quantity (MDQ) (definition)	3.3.20
Detection systems	4.3.1, 4.3.2, 7.7.2.4.4, 7.7.2.4.7 to 7.7.2.4.9, A.4.3.2.1
Functional tests	7.7.2.5.1, 7.7.2.5.2
Marine systems	8.5, 8.6.1, A.8.5.1.2, A.8.5.2.3, A.8.6.1
Working plans	5.1.2.2(16), 5.1.2.2(18), 5.1.2.2(26)
Discharge delays	4.3.5.6, A.4.3.5.6.1
Discharge nozzles	4.2.5, A.5.2.1
Discharge pressures, dynamic	C.1.2.3.1
Discharge tests	7.7.2.2.10, A.7.7.2.2.10
Discharge time	5.7.1.2, A.5.2.1, A.5.7.1.2
Local application systems	6.3, 6.4.1, 6.4.3, A.6.4.1.1 to A.6.4.1.3, A.6.4.3.3
Marine systems	8.9.2
Disposal of agents	7.1.4, 7.1.5, A.7.1.4
Distribution system	4.2, A.4.2.1 to A.4.2.4.2
Discharge time	5.7.1.2, A.5.7.1.2
Marine systems	8.9.2
Extended discharge	5.7.2, A.5.7.2
Flow calculations	5.1.2.5, 5.2, A.5.2
Inspection and testing of	7.7.2.2, A.7.7.2.2.10, A.7.7.2.2.13
Marine systems	8.9
Rate of application	5.7.1, A.5.7.1.2
Marine systems	8.9.1
Working plans	5.1.2.2(14), 5.1.2.2(18), 5.1.2.2(19), 5.1.2.2(21)
Door fans	7.7.2.3
Definition	C.1.3.10
Enclosure evaluation	C.2.5
Equipment required	C.2.2.1
Installation	C.2.4
Measurement	C.1.2.2
Leakage calculation	C.2.6.3
Suspended ceiling leakage neutralization method	C.2.6.2
Total enclosure leakage method	C.2.6.1
Test procedure	Annex C
DOT	<i>see</i> U. S. Dept. of Transportation (DOT), regulations
Duration of protection	5.6, A.5.6
Marine systems	8.8.5, A.8.8.5

-E-

Effective floor area (definition)	C.1.3.1
Effective flow area (definition)	C.1.3.2
Electrical and electronic hazards, use for	A.1.4.2; <i>see also</i>
Class C fire	
Marine systems	A.8.2.1
Electrical clearances	1.5.2, 8.3.2, A.8.3.2
Definition	3.3.7
Electrical systems/components	
Inspection of	7.7.2.4
Marine	8.14
Circuits, cylinder storage space	8.6.2 to 8.6.4, 8.6.6, A.8.6.2 to A.8.6.4, A.8.6.6
Working plans	5.1.2.2(15), 5.1.2.2(24) to (26)
Electric control equipment	4.3.4.1
Electrostatic charging, ungrounded conductors	A.1.4.2.2
Employees	
Hazards to	1.5.1, 8.3, A.1.5.1, A.8.3.2
Safety requirements	1.5.1.4, 7.8, A.1.5.1.4.1 to A.1.5.1.4.4, A.7.8
Training	7.6, A.7.6.2

Enclosures	
Definition	C.1.3.11
Design	5.3, A.5.3.5, A.5.3.6
Evaluation	Annex D
Explosion hazard of	A.1.4.2
Inspection	7.4
Integrity procedure	7.7.2.3, A.7.7.2.3, Annex C; <i>see also</i>
Door fans	
Field calibration check	C.2.2.3
Fundamentals	C.1
Leakage control	C.2.8
Limitations and assumptions	C.1.2
Retention calculation	C.1.2.3, C.2.7
Test procedure	C.2
Marine systems	8.7, A.8.7.1, A.8.7.2
Pressurization levels	5.1.2.2(10), 5.1.2.2(28), 5.3.3, 5.3.6, 5.5.3.3, A.5.1.2.2(28), A.5.3.6, A.5.5.3.3
Protected (definition)	C.1.3.13
Safety requirements	1.5.1.4.3
Sealing	7.5.3, 8.7.1(1), A.7.5.3, A.8.7.1
Total flooding systems used in	1.4.2.3, A.1.4.2
Working plans	5.1.2.2(10), 5.1.2.2(18), 5.1.2.2(26)
Enclosure envelope (definition)	C.1.3.12
Engineered systems (definition)	3.3.10
Environmental factors	1.6, A.1.6
Equivalent leakage area (ELA)	5.1.2.2(28), A.5.1.2.2(28)
Calculation	C.2.6.1.1
Definition	C.1.3.3
Evaluation, enclosures	Annex D
Explosion prevention/suppression	5.7.1.2.5, A.1.4.2
Extended discharge	5.7.2, A.5.7.2

-F-

Fan pressurization apparatus (definition)	C.1.3.14
FC	<i>see</i> Perfluorocarbons (FCs)
FIC	<i>see</i> Fluoroiodocarbons (FICs)
Field calibration check, enclosure integrity	C.2.2.3
Fill density	
Containers	4.1.4.1, A.4.1.4.1
Definition	3.3.11
Final design quantity (FDQ) (definition)	3.3.12
Fittings	4.2.3, A.4.2.3.1
Flow calculations	5.2.2
Marine systems	8.4.6, 8.4.7, A.8.4.6, A.8.4.7
Working plans	5.1.2.2(14), 5.1.2.2(19)
FK	<i>see</i> Fluoroketones (FKs)
Flame extinguishment concentrations	5.4.2, A.5.4.2
Marine systems	8.8.3
Method for determining	Annex B
Flammable and combustible liquid fires	<i>see</i> Class B fire
Floor area, enclosure integrity	C.1.2.3.4
Floor slab (definition)	C.1.3.15
Flow calculations	5.1.2.5, 5.2, A.5.2
Flow pressure gauge (definition)	C.1.3.16
Flow tests	7.7.2.2.13, A.7.7.2.2.13
Fluoroiodocarbons (FICs)	A.1.4.1.2
Isometric diagrams	Fig. A.4.1.4.1(b)
Physical properties	Table A.1.4.1(a), Table A.1.4.1(c)
Safe human exposure, time for	Table 1.5.1.2(e)
Total flooding quantity	Table A.5.5.1(q), Table A.5.5.1(r)
Fluoroketones (FKs)	A.1.4.1.2
Physical properties	Table A.1.4.1(a), Table A.1.4.1(c)
Total flooding quantity	Table A.5.5.1(a), Table A.5.5.1(b)
Forced-air ventilating systems	5.3.5, A.5.3.5
Functional testing	7.7.2.5

-H-

Halocarbon agents	
Compatibility	A.1.8.1
Containers	4.1.4.2(1), 4.1.4.5(1), A.4.1.4.1, A.4.1.4.2
Decomposition	A.1.5.1.2, A.5.5.3.3, A.5.7.1.2



Definition 3.3.13, A.3.3.13
 Design concentration 5.5.1, A.5.5.1
 Discharge time 5.7.1.2.1, 8.9.2.1, 8.9.2.2, A.5.7.1.2.1
 Distribution 4.2.1.1, Table 4.2.1.1(b), A.4.2.1.1
 Employees, hazards to 1.5.1.2, A.1.5.1.2
 Flame extinguishment concentrations 5.4.2.2, A.5.4.2.2, Table A.5.4.2.2(b)
 Inspection and tests 7.1.3.1, 7.1.6, 8.11.3, A.8.11.3
 Physical properties Table A.1.4.1(a), Table A.1.4.1(c)
 Recycling or disposal of 7.1.4, A.4.1.4.2, A.7.1.4

Hazards
 Clean agent systems used for ... 1.4.2, 6.2, 6.5.1, 6.5.3, 8.6, A.1.5.1, A.6.5.1, A.8.6.1 to A.8.6.6
 To employees 1.5.1, 8.3, A.1.5.1, A.8.3.2

HCFC *see* Hydrochlorofluorocarbons (HCFCs)
HF *see* Hydrogen fluoride (HF)
HFC *see* Hydrofluorocarbons (HFCs)
Hose test 7.3
Hydrochlorofluorocarbons (HCFCs) A.1.4.1.2
 HCFC Blend A
 Isometric diagrams Fig. A.4.1.4.1(d)
 Physical properties Table A.1.4.1(a), Table A.1.4.1(c)
 Quality Table 4.1.2(c)
 Total flooding quantity Table A.5.5.1(e), Table A.5.5.1(f)
 HCFC Blend B
 Isometric diagrams Fig. A.4.1.4.1(n)
 Physical properties Table A.1.4.1(a), Table A.1.4.1(c)
 Quality Table 4.1.2(d)
 Isometric diagrams Fig. A.4.1.4.1(d), Fig. A.4.1.4.1(e)
 Physical properties Table A.1.4.1(a), Table A.1.4.1(c)
 Total flooding quantity Tables A.5.5.1(e) to A.5.5.1(h)

Hydrofluorocarbons (HFCs) A.1.4.1.2
 Isometric diagrams Figs. A.4.1.4.1(f) to (i), Fig. A.4.1.4.1(n)
 Physical properties Table A.1.4.1(a), Table A.1.4.1(c)
 Safe human exposure, time for Tables 1.5.1.2(b) to 1.5.1.2(d)
 Total flooding quantity Tables A.5.5.1(i) to A.5.5.1(p)

Hydrogen fluoride (HF)
 Background and toxicology of A.1.5.1.2
 Decomposition and A.5.7.1.2

-I-

Identification, piping systems 4.2.1.3
IG-01 *see* Argon (IG-01)
IG-55
 Isometric diagrams Fig. A.4.1.4.1(m)
 Physical properties Table A.1.4.1(b), Table A.1.4.1(d)
 Total flooding quantity Table A.5.5.2(g), Table A.5.5.2(h)
IG-100 *see* Nitrogen (IG-100)
IG-541 A.1.4.1.2, A.1.5.1.3
 Isometric diagram Fig. A.4.1.4.1(l)
 Physical properties Table A.1.4.1(b), Table A.1.4.1(d)
 Total flooding quantity Table A.5.5.2(e), Table A.5.5.2(f)
Indicators, operating 4.3.5
Indicators, refillable containers 4.1.4.4
Inert gas
 Flow test using 7.7.2.2.13, A.7.7.2.2.13
 Predischarge alarms operated by 1.5.1.4.4, A.1.5.1.4.4

Inert gas agents
 Compatibility A.1.8.1
 Containers 4.1.4.2(2), 4.1.4.5(2), A.4.1.4.2, A.4.1.4.5(2)
 Decomposition A.1.5.1.3
 Definition 3.3.14
 Designations for A.1.4.1.2
 Design concentration 5.5.2, A.5.5.2
 Discharge time 5.7.1.2.2, 8.9.2.3, A.5.7.1.2.1
 Distribution 4.2.1.1, Table 4.2.1.1.1(a), A.4.2.1.1, A.5.2
 Employees, hazards to 1.5.1.3, A.1.5.1.3
 Flame extinguishment concentrations 5.4.2.2, A.5.4.2.2, Table A.5.4.2.2(b)

Inspection and tests 7.1.3.2, 7.1.6, 8.11.3.1, A.7.1.4
 Physical properties Table A.1.4.1(b), Table A.1.4.1(d)
 Quality Table 4.1.2(b)
Inerting concentrations 5.1.2.2(8), 5.4.3, A.5.4.3
Inspection 7.1, A.7.1.4
 Electrical components 7.7.2.4
 Enclosures 7.4, 7.7.2.3, A.7.7.2.3, C.2.3.1
 Marine systems 8.11, A.8.11.3
 Mechanical components 7.7.2.2, A.7.7.2.2.10, A.7.7.2.2.13
 Records/reports 7.1.2, 7.1.6, 7.2.2, 8.11.1, 8.11.2, A.7.2.2
 Safety training of inspectors 1.5.1.5
 Visual 7.2.2, A.7.2.2
Installations, approval of 7.7, A.7.7.2.2.10 to A.7.7.2.3
 Marine systems 8.12

-J-

Joints, pipe 4.2.2, 7.7.2.2.3

-L-

Leakage calculation C.2.6.3
Leaks, enclosure ... 7.7.2.3, A.7.7.2.3; *see also* Equivalent leakage area (ELA)
 Alteration C.2.8.2
 Discharge C.1.2.3.8
 Flow characteristics C.1.2.3.6
 Flow direction C.1.2.3.7
 Identification C.2.8.1
 Leak fraction calculation C.2.7.1.3
 Location C.1.2.2, C.1.2.3.9
 Measurement C.2.6.1, C.2.6.2
 Retention calculation C.2.7.1
Limitations, of systems 1.4.2, A.1.4.2
 Marine systems 8.2, A.8.2.1, A.8.2.2
Listed (definition) 3.2.3, A.3.2.3
Local application system Chap. 6
 Definition 3.3.15
Lockout valve 1.5.1.4.3
 Definition 3.3.16
Lower leakage calculation C.2.7.1.2
Lowest observable adverse effect level (LOAEL)
 Definition 3.3.17
 Employee safety 1.5.1.2.1, A.1.5.1.2

-M-

Machinery spaces
 Definition 3.3.18
 Hazards to employees 8.3.1
 Total flooding systems A.8.2.1
Maintenance 1.5.1.5, 7.5, A.7.5
Manifolded storage containers 4.1.3.5, 4.1.4.5, A.4.1.4.5(2)
Manual actuation systems 4.3.3.5 to 4.3.3.7, 4.3.3.10, A.4.3.3.5.1, A.5.5.3.3
 Design concentration, minimum 5.4.2.3
 Installation acceptance 7.7.2.4.10, 7.7.2.4.11, 7.7.2.4.13, 7.7.2.5.2(3)
 Local application systems 6.6, A.6.6
 Marine systems 8.5.2.2 to 8.5.2.5, A.8.5.2.3
Marine systems Chap. 8
 Agent supply 8.4
 Approval of installations 8.12
 Class B hazards greater than 6000 ft, systems protecting 8.6, A.8.6.1 to A.8.6.6
 Definition 3.3.19
 Design concentration requirements 8.8, A.8.8.4, A.8.8.5
 Detection, actuation, and control systems 8.5, A.8.5.1.2, A.8.5.2.3
 Distribution system 8.9
 Electrical systems, compliance of 8.14
 Enclosure 8.7, A.8.7.1, A.8.7.2
 Hazards to personnel 8.3, A.8.3.2
 Inspection and tests 8.11, A.8.11.3

Nozzle placement	8.10
Periodic puff testing	8.13
Use and limitations of	8.2, A.8.2.1, A.8.2.2
Maximum protected height (definition)	C.1.3.18
Measurement, units of	1.3
Mechanical components, inspection of	7.7.2.2, A.7.7.2.2.10, A.7.7.2.2.13
Metal fires, use on	1.4.2.2, 6.4.3.2, A.1.4.2.2
Minimum design quantity (MDQ) (definition)	3.3.20
Minimum protected height	
Calculation	C.2.7.1.6
Definition	C.1.3.19
Minimum time calculation	C.2.7.1.7

-N-

Nitrogen-argon-carbon dioxide blend	<i>see</i> IG-541
Nitrogen-argon inerting blend	<i>see</i> IG-55
Nitrogen (IG-100)	
Flow testing with	7.7.2.2.13, A.7.7.2.2.13
Inerting use	A.1.4.1.2
Isometric diagrams	Fig. A.4.1.4.1(k)
Physical properties	Table A.1.4.1(b), Table A.1.4.1(d)
Total flooding quantity	Table A.5.5.2(c), Table A.5.5.2(d)
No observed adverse effect level (NOAEL)	
Definition	3.3.21
Employee safety	1.5.1.2.1, A.1.5.1.2, A.1.5.1.4.2
Normally occupied enclosure or space	
Definition	3.3.22, A.3.3.22
Halocarbon fire extinguishing agents	1.5.1.2.1, A.1.5.1.2
Safety requirements	1.5.1.4.3
Nozzles	
Choice and location	5.8, 8.10
Discharge	4.2.5, 7.7.2.2.3, 7.7.2.2.5, A.5.2.1
Inspection and testing of	7.7.2.2.2 to 7.7.2.2.7
Local application system	6.1, 6.4, 6.5, A.6.1.3, A.6.4.1.1 to A.6.4.3.3, A.6.5.1, A.6.5.4
Marine systems	8.4.7, 8.4.8, A.8.4.7
Working plans	5.1.2.2(13), 5.1.2.2(18), 5.1.2.2(19)

-O-

Occupiable enclosure or space	
Definition	3.3.23
Operating devices	4.3.3, 4.3.5, A.4.3.3.5.1
Marine systems	8.5.2.5
Working plans	5.1.2.2(23)
Oxygen, sea level equivalent of	A.1.5.1.3
Definition	3.3.28
Oxygen concentrations, personnel safety	1.5.1.3, A.1.5.1.3

-P-

Perfluorocarbons (FCs)	A.1.4.1.2
Isometric diagrams	Fig. A.4.1.4.1(a)
Total flooding quantity	Table A.5.5.1(d), Table A.5.5.1(c)
Periodic puff testing	8.13
Piping	4.2.1, 4.2.2, A.4.2.1
Flow calculations	5.1.2.5, 5.2, A.5.2
Inspection and testing of	7.7.2.2, A.7.7.2.2.10, A.7.7.2.2.13
Joints	7.7.2.2.3
Local application systems	6.1, A.6.1.3
Marine systems	8.4.6 to 8.4.8, A.8.4.6, A.8.4.7
Working plans	5.1.2.2(14), 5.1.2.2(18), 5.1.2.2(19), 5.1.2.2(21)
Plans, working	5.1.2, A.5.1.2.2(28)
Approval of	5.1.3
Flow calculations	5.1.2.5, 5.2, A.5.2
Plastic fuel properties	Table A.5.4.2.2(a)
Pneumatic control equipment	1.5.1.4.3, 1.5.1.4.4, 4.3.4.2, A.1.5.1.4.4
Pneumatic pressure testing	7.7.2.2.12

Power sources	
Marine systems	8.5.2.1
Testing of	7.7.2.5.4
Pre-engineered systems	5.7.1.2.4
Definition	3.3.24
Design	5.1.2.3.1
Discharge time period	A.5.7.1.2.3
Flow calculations	5.2.1.1
Tests	A.5.4.2.2
Use and limitations	1.4.2.1
Preliminary functional test	7.7.2.5.1
Pressure	
Nozzles	A.5.2.1
Specified pressure limit	5.1.2.2(28), A.5.1.2.2(28)
Stored cylinders	8.6.5, A.8.6.5
Pressure adjustment	5.5.3.3, A.5.5.3.3
Pressure differentials, enclosure	5.1.2.2(28), A.5.1.2.2(28), C.1.2.1, C.1.2.3.2, C.2.5.2, C.2.7.1.5
Pressure gauge	
Flow pressure gauge (definition)	C.1.3.16
Room (definition)	C.1.3.17
Pressure relief devices	4.2.1.6, 4.2.1.7, A.4.1.4.1, A.4.2.1.6
Pressure testing	7.1.3, 7.7.2.2.12
Pressurization levels	
Containers	4.1.4.1, 4.1.4.4, A.4.1.4.1
Enclosures	5.1.2.2(10), 5.1.2.2(28), 5.3.3, 5.3.6, 5.5.3.3, A.5.1.2.2(28), A.5.3.6, A.5.5.3.3
Fittings	4.2.3.1, 4.2.3.6, A.4.2.3.1
Marine systems	8.11.2, 8.11.3, A.8.11.3
Piping	4.2.1.1, 4.2.1.6, A.4.2.1.1, A.4.2.1.6
Primary agent supply	
Primary power source	
Marine systems	8.5.2.1
Testing of	7.7.2.5.4
Protected enclosure (definition)	C.1.3.13; <i>see also</i> Enclosures
Protected height	
Maximum (definition)	C.1.3.18
Minimum	<i>see</i> Minimum protected height
Puff test	8.13
Pump rooms	
Definition	3.3.25
Total flooding systems	A.8.2.1
Purpose of standard	1.2

-R-

Records/reports	
Enclosure integrity procedure	7.7.2.3, C.2.9
Inspection	7.1.6, 7.2.2, 8.11.1, 8.11.2, A.7.2.2
Recycling of agents	7.1.4, 7.1.5, A.4.1.2, A.4.1.4.2, A.7.1.4
References	Chap. 2, Annex E
Remote monitoring operations	X:7.7.2.5.3
Reports	<i>see</i> Records/reports
Reserve agent supply	4.1.1.2, 4.1.1.3, 8.4.1, A.4.1.1.2
Retention calculation, enclosure	C.1.2.3, C.2.7
Retrofitability, clean agents to existing system	1.7
Return path	
Definition	C.1.3.20
Door fan measurements	C.1.2.2
Return path area (definition)	C.1.3.4
Room pressure gauge (definition)	C.1.3.17

-S-

Safety	1.5, 6.1.3, 7.8, A.1.5.1, A.6.1.3, A.7.8
Safety factor (SF) (definition)	3.3.26
Scope of standard	1.1
Sea level equivalent of agent (definition)	3.3.27
Sea level equivalent of oxygen	A.1.5.1.3
Definition	3.3.28
Shall (definition)	3.2.4
Shipping containers, DOT regulations	4.1.4.3



- Should (definition)** 3.2.5
- Signs, warning and instruction** 1.5.1.4.1, 1.5.1.4.3, 4.3.5.5, A.1.5.1.4.1
- SI units** 1.3
- Specifications** 5.1.1
- Static pressure differential**
- Calculation C.2.7.1.5
 - Definition C.1.3.21
 - Door fan test C.1.2.1, C.1.2.3.2, C.2.5.2
- Steel pipe** 4.2.1.2, 4.2.3.6
- Storage containers** *see* Containers
- Superpressurization**
- Containers 4.1.4.1, 4.1.4.4, A.4.1.4.1
 - Definition 3.3.29
- Suspended ceiling leakage neutralization method, door fan measurement** C.2.6.2
- System design** Chap. 5
- System functional operational test** 7.7.2.5.2
- T-**
- Tee design factor** 5.5.3.1, A.5.5.3.1, A.5.5.3.2
- Temperatures** 8.4.2.2
- Clean agents and 1.4.2.4, 4.2.1.1, A.1.4.2.4, A.1.5.1, A.1.5.1.2, A.4.1.4.1
 - Containers 4.1.4.6
 - Enclosure integrity C.1.2.3.3
- Tests** 7.1, A.7.1.4
- Container 7.2, A.7.2.2
 - Cup burner method for determining agent concentration 5.4.2.1, A.5.4.2, Annex B
 - Discharge 7.7.2.2.10, A.7.7.2.2.10
 - Door fan test procedure Annex C
 - Flow 7.7.2.2.13, A.7.7.2.2.13
 - Functional 7.7.2.5
 - Hose 7.3
 - Local application systems for 6.1.1
 - Marine systems 8.11, 8.13, A.8.11.3
 - Piping, pneumatic testing of 7.7.2.2.12
 - Primary power source 7.7.2.5.4
 - Safety training of testers 1.5.1.5
 - Time delays** 1.5.1.4.3, 4.3.5.6, A.1.5.1.2, A.4.3.5.6.1
 - Total enclosure leakage method, door fan measurement** C.2.6.1
 - Total flooding**
 - Definition 3.3.30
 - Quantity 5.5, A.5.5.1 to A.5.5.3
 - Marine systems 8.8.4, A.8.8.4 - Total flooding system**
 - Definition 3.3.31
 - Design 5.3.1
 - Enclosure integrity 7.7.2.3, A.7.7.2.3
 - Use and limitations 1.4.2.3, A.1.4.2
 - Marine systems 8.2.1, A.8.2.1 - Training** 1.5.1.5, 7.6, A.7.6.2
- U-**
- Uninterrupted protection** 4.1.1.3
- U. S. Dept. of Transportation (DOT), regulations** 4.1.4.3, 7.2.1, A.7.2.1
- Units of measurement** 1.3
- Unwanted system operation** 4.3.6, A.4.3.6
- Uses, of systems** 1.4.2, A.1.4.2
- Local application systems 6.1.1
 - Marine systems 8.2, A.8.2.1, A.8.2.2
- V-**
- Valves** 4.2.4, A.4.2.4.2
- Flow calculations 5.2.2
 - Marine systems 8.4.6, A.8.4.6
 - Multi-hazard protection, used for 4.2.4.4, 4.2.4.5
- Ventilating systems** 5.3.5, A.1.5.1.4.1, A.5.3.5, A.5.5.3.3
- Marine systems 8.4.2.2, 8.7.2, A.8.7.2
- Venting, piping systems** 4.2.1.6, A.4.2.1.6
- Visual inspection** 7.2.2, A.7.2.2

Sequence of Events Leading to Issuance of an NFPA Committee Document

Step 1: Call for Proposals

- Proposed new Document or new edition of an existing Document is entered into one of two yearly revision cycles, and a Call for Proposals is published.

Step 2: Report on Proposals (ROP)

- Committee meets to act on Proposals, to develop its own Proposals, and to prepare its Report.
- Committee votes by written ballot on Proposals. If two-thirds approve, Report goes forward. Lacking two-thirds approval, Report returns to Committee.
- Report on Proposals (ROP) is published for public review and comment.

Step 3: Report on Comments (ROC)

- Committee meets to act on Public Comments to develop its own Comments, and to prepare its report.
- Committee votes by written ballot on Comments. If two-thirds approve, Report goes forward. Lacking two-thirds approval, Report returns to Committee.
- Report on Comments (ROC) is published for public review.

Step 4: Technical Report Session

- “*Notices of intent to make a motion*” are filed, are reviewed, and valid motions are certified for presentation at the Technical Report Session. (“Consent Documents” that have no certified motions bypass the Technical Report Session and proceed to the Standards Council for issuance.)
- NFPA membership meets each June at the Annual Meeting Technical Report Session and acts on Technical Committee Reports (ROP and ROC) for Documents with “certified amending motions.”
- Committee(s) vote on any amendments to Report approved at NFPA Annual Membership Meeting.

Step 5: Standards Council Issuance

- Notification of intent to file an appeal to the Standards Council on Association action must be filed within 20 days of the NFPA Annual Membership Meeting.
- Standards Council decides, based on all evidence, whether or not to issue Document or to take other action, including hearing any appeals.

Committee Membership Classifications

The following classifications apply to Technical Committee members and represent their principal interest in the activity of the committee.

- M *Manufacturer*: A representative of a maker or marketer of a product, assembly, or system, or portion thereof, that is affected by the standard.
- U *User*: A representative of an entity that is subject to the provisions of the standard or that voluntarily uses the standard.
- I/M *Installer/Maintainer*: A representative of an entity that is in the business of installing or maintaining a product, assembly, or system affected by the standard.
- L *Labor*: A labor representative or employee concerned with safety in the workplace.
- R/T *Applied Research/Testing Laboratory*: A representative of an independent testing laboratory or independent applied research organization that promulgates and/or enforces standards.
- E *Enforcing Authority*: A representative of an agency or an organization that promulgates and/or enforces standards.
- I *Insurance*: A representative of an insurance company, broker, agent, bureau, or inspection agency.
- C *Consumer*: A person who is, or represents, the ultimate purchaser of a product, system, or service affected by the standard, but who is not included in the *User* classification.
- SE *Special Expert*: A person not representing any of the previous classifications, but who has a special expertise in the scope of the standard or portion thereof.

NOTES;

1. “Standard” connotes code, standard, recommended practice, or guide.
2. A representative includes an employee.
3. While these classifications will be used by the Standards Council to achieve a balance for Technical Committees, the Standards Council may determine that new classifications of members or unique interests need representation in order to foster the best possible committee deliberations on any project. In this connection, the Standards Council may make appointments as it deems appropriate in the public interest, such as the classification of “Utilities” in the National Electrical Code Committee.
4. Representatives of subsidiaries of any group are generally considered to have the same classification as the parent organization.

NFPA Technical Committee Document Proposal Form

NOTE: All Proposals must be received by 5:00 pm EST/EDST on the published Proposal Closing Date.

For further information on the standards-making process, please contact the Codes and Standards Administration at 617-984-7249 or visit www.nfpa.org/codes.

For technical assistance, please call NFPA at 1-888-344-3555.

FOR OFFICE USE ONLY

Log #: _____

Date Rec'd: _____

Please indicate in which format you wish to receive your ROP/ROC electronic paper download
(Note: If choosing the download option, you must view the ROP/ROC from our website; no copy will be sent to you.)

Date April 1, 200X Name John J. Doe Tel. No. 716-555-1234

Company Air Canada Pilot's Association

Street Address 123 Summer Street Lane City Lewiston State NY Zip 14092

Please indicate organization represented (if any) _____

1. (a) NFPA Document Title National Fuel Gas Code NFPA No. & Year 54, 200X Edition

(b) Section/Paragraph 3.3

2. Proposal Recommends (check one): new text revised text deleted text

3. Proposal (include proposed new or revised wording, or identification of wording to be deleted): [Note: Proposed text should be in legislative format; i.e., use underscore to denote wording to be inserted (inserted wording) and strike-through to denote wording to be deleted (~~deleted wording~~).]

Revise definition of effective ground-fault current path to read:

3.3.78 Effective Ground-Fault Current Path. An intentionally constructed, permanent, low impedance electrically conductive path designed and intended to carry underground electric fault current conditions from the point of a ground fault on a wiring system to the electrical supply source.

4. Statement of Problem and Substantiation for Proposal: (Note: State the problem that would be resolved by your recommendation; give the specific reason for your Proposal, including copies of tests, research papers, fire experience, etc. If more than 200 words, it may be abstracted for publication.)

Change uses proper electrical terms.

5. Copyright Assignment

(a) I am the author of the text or other material (such as illustrations, graphs) proposed in this Proposal.

(b) Some or all of the text or other material proposed in this Proposal was not authored by me. Its source is as follows (please identify which material and provide complete information on its source):

ABC Co.

I agree that any material that I author, either individually or with others, in connection with work performed by an NFPA Technical Committee shall be considered to be works made for hire for the NFPA. To the extent that I retain any rights in copyright as to such material, or as to any other material authored by me that I submit for the use of an NFPA Technical Committee in the drafting of an NFPA code, standard, or other NFPA document, I hereby grant and assign all and full rights in copyright to the NFPA. I further agree and acknowledge that I acquire no rights in any publication of the NFPA and that copyright and all rights in materials produced by NFPA Technical Committees are owned by the NFPA and that the NFPA may register copyright in its own name.

Signature (Required) _____

PLEASE USE SEPARATE FORM FOR EACH PROPOSAL • NFPA Fax: (617) 770-3500

Mail to: Secretary, Standards Council, National Fire Protection Association, 1 Batterymarch Park, Quincy, MA 02169-7471

6/8/2007

NFPA Technical Committee Document Proposal Form

NOTE: All Proposals must be received by 5:00 pm EST/EDST on the published Proposal Closing Date.

For further information on the standards-making process, please contact the Codes and Standards Administration at 617-984-7249 or visit www.nfpa.org/codes.

For technical assistance, please call NFPA at 1-888-344-3555.

FOR OFFICE USE ONLY

Log #: _____

Date Rec'd: _____

Please indicate in which format you wish to receive your ROP/ROC electronic paper download
(Note: If choosing the download option, you must view the ROP/ROC from our website; no copy will be sent to you.)

Date _____ Name _____ Tel. No. _____

Company _____

Street Address _____ City _____ State _____ Zip _____

Please indicate organization represented (if any) _____

1. (a) NFPA Document Title _____ NFPA No. & Year _____

(b) Section/Paragraph _____

2. Proposal Recommends (check one): new text revised text deleted text

3. Proposal (include proposed new or revised wording, or identification of wording to be deleted): [Note: Proposed text should be in legislative format; i.e., use underscore to denote wording to be inserted (inserted wording) and strike-through to denote wording to be deleted (~~deleted wording~~).]

4. Statement of Problem and Substantiation for Proposal: (Note: State the problem that would be resolved by your recommendation; give the specific reason for your Proposal, including copies of tests, research papers, fire experience, etc. If more than 200 words, it may be abstracted for publication.)

5. Copyright Assignment

(a) I am the author of the text or other material (such as illustrations, graphs) proposed in this Proposal.

(b) Some or all of the text or other material proposed in this Proposal was not authored by me. Its source is as follows (please identify which material and provide complete information on its source):

I agree that any material that I author, either individually or with others, in connection with work performed by an NFPA Technical Committee shall be considered to be works made for hire for the NFPA. To the extent that I retain any rights in copyright as to such material, or as to any other material authored by me that I submit for the use of an NFPA Technical Committee in the drafting of an NFPA code, standard, or other NFPA document, I hereby grant and assign all and full rights in copyright to the NFPA. I further agree and acknowledge that I acquire no rights in any publication of the NFPA and that copyright and all rights in materials produced by NFPA Technical Committees are owned by the NFPA and that the NFPA may register copyright in its own name.

Signature (Required) _____

PLEASE USE SEPARATE FORM FOR EACH PROPOSAL • NFPA Fax: (617) 770-3500

Mail to: Secretary, Standards Council, National Fire Protection Association, 1 Batterymarch Park, Quincy, MA 02169-7471

6/8/2007