

NFPA® 91

Standard for
Exhaust Systems for
Air Conveying of Vapors,
Gases, Mists, and
Noncombustible
Particulate Solids

2010 Edition



NFPA, 1 Batterymarch Park, Quincy, MA 02169-7471
An International Codes and Standards Organization

IMPORTANT NOTICES AND DISCLAIMERS CONCERNING NFPA® DOCUMENTS
NOTICE AND DISCLAIMER OF LIABILITY CONCERNING THE USE OF NFPA DOCUMENTS

NFPA® codes, standards, recommended practices, and guides (“NFPA Documents”), of which the document contained herein is one, are developed through a consensus standards development process approved by the American National Standards Institute. This process brings together volunteers representing varied viewpoints and interests to achieve consensus on fire and other safety issues. While the NFPA administers the process and establishes rules to promote fairness in the development of consensus, it does not independently test, evaluate, or verify the accuracy of any information or the soundness of any judgments contained in NFPA Documents.

The NFPA disclaims liability for any personal injury, property or other damages of any nature whatsoever, whether special, indirect, consequential or compensatory, directly or indirectly resulting from the publication, use of, or reliance on NFPA Documents. The NFPA also makes no guaranty or warranty as to the accuracy or completeness of any information published herein.

In issuing and making NFPA Documents available, the NFPA is not undertaking to render professional or other services for or on behalf of any person or entity. Nor is the NFPA undertaking to perform any duty owed by any person or entity to someone else. Anyone using this document should rely on his or her own independent judgment or, as appropriate, seek the advice of a competent professional in determining the exercise of reasonable care in any given circumstances.

The NFPA has no power, nor does it undertake, to police or enforce compliance with the contents of NFPA Documents. Nor does the NFPA list, certify, test, or inspect products, designs, or installations for compliance with this document. Any certification or other statement of compliance with the requirements of this document shall not be attributable to the NFPA and is solely the responsibility of the certifier or maker of the statement.

ISBN: 978-087765923-5 (Print)
ISBN: 978-087765971-6 (PDF)

12/09

IMPORTANT NOTICES AND DISCLAIMERS CONCERNING NFPA DOCUMENTS

ADDITIONAL NOTICES AND DISCLAIMERS

Updating of NFPA Documents

Users of NFPA codes, standards, recommended practices, and guides (“NFPA Documents”) should be aware that these documents may be superseded at any time by the issuance of new editions or may be amended from time to time through the issuance of Tentative Interim Amendments. An official NFPA Document at any point in time consists of the current edition of the document together with any Tentative Interim Amendments and any Errata then in effect. In order to determine whether a given document is the current edition and whether it has been amended through the issuance of Tentative Interim Amendments or corrected through the issuance of Errata, consult appropriate NFPA publications such as the National Fire Codes® Subscription Service, visit the NFPA website at www.nfpa.org, or contact the NFPA at the address listed below.

Interpretations of NFPA Documents

A statement, written or oral, that is not processed in accordance with Section 6 of the Regulations Governing Committee Projects shall not be considered the official position of NFPA or any of its Committees and shall not be considered to be, nor be relied upon as, a Formal Interpretation.

Patents

The NFPA does not take any position with respect to the validity of any patent rights referenced in, related to, or asserted in connection with an NFPA Document. The users of NFPA Documents bear the sole responsibility for determining the validity of any such patent rights, as well as the risk of infringement of such rights, and the NFPA disclaims liability for the infringement of any patent resulting from the use of or reliance on NFPA Documents.

NFPA adheres to the policy of the American National Standards Institute (ANSI) regarding the inclusion of patents in American National Standards (“the ANSI Patent Policy”), and hereby gives the following notice pursuant to that policy:

NOTICE: The user’s attention is called to the possibility that compliance with an NFPA Document may require use of an invention covered by patent rights. NFPA takes no position as to the validity of any such patent rights or as to whether such patent rights constitute or include essential patent claims under the ANSI Patent Policy. If, in connection with the ANSI Patent Policy, a patent holder has filed a statement of willingness to grant licenses under these rights on reasonable and nondiscriminatory terms and conditions to applicants desiring to obtain such a license, copies of such filed statements can be obtained, on request, from NFPA. For further information, contact the NFPA at the address listed below.

Law and Regulations

Users of NFPA Documents should consult applicable federal, state, and local laws and regulations. NFPA does not, by the publication of its codes, standards, recommended practices, and guides, intend to urge action that is not in compliance with applicable laws, and these documents may not be construed as doing so.

Copyrights

NFPA Documents are copyrighted by the NFPA. They are made available for a wide variety of both public and private uses. These include both use, by reference, in laws and regulations, and use in private self-regulation, standardization, and the promotion of safe practices and methods. By making these documents available for use and adoption by public authorities and private users, the NFPA does not waive any rights in copyright to these documents.

Use of NFPA Documents for regulatory purposes should be accomplished through adoption by reference. The term “adoption by reference” means the citing of title, edition, and publishing information only. Any deletions, additions, and changes desired by the adopting authority should be noted separately in the adopting instrument. In order to assist NFPA in following the uses made of its documents, adopting authorities are requested to notify the NFPA (Attention: Secretary, Standards Council) in writing of such use. For technical assistance and questions concerning adoption of NFPA Documents, contact NFPA at the address below.

For Further Information

All questions or other communications relating to NFPA Documents and all requests for information on NFPA procedures governing its codes and standards development process, including information on the procedures for requesting Formal Interpretations, for proposing Tentative Interim Amendments, and for proposing revisions to NFPA documents during regular revision cycles, should be sent to NFPA headquarters, addressed to the attention of the Secretary, Standards Council, NFPA, 1 Batterymarch Park, P.O. Box 9101, Quincy, MA 02169-7471; email: stds_admin@nfpa.org

For more information about NFPA, visit the NFPA website at www.nfpa.org.

Copyright © 2009 National Fire Protection Association®. All Rights Reserved.

NFPA® 91

Standard for

Exhaust Systems for Air Conveying of Vapors, Gases, Mists, and Noncombustible Particulate Solids

2010 Edition

This edition of NFPA 91, *Standard for Exhaust Systems for Air Conveying of Vapors, Gases, Mists, and Noncombustible Particulate Solids*, was prepared by the Technical Committee on Handling and Conveying of Dusts, Vapors, and Gases. It was issued by the Standards Council on October 27, 2009, with an effective date of December 5, 2009, and supersedes all previous editions.

This edition of NFPA 91 was approved as an American National Standard on December 5, 2009.

Origin and Development of NFPA 91

The National Fire Protection Association as early as 1899 recognized the hazards of blower and exhaust systems. Since 1900, the NFPA Committee on Blower Systems has given continuing attention to the subject. Following World War II, revisions and additions to the standard were recommended by the NFPA Committee on Blower Systems to cover various new developments in the protection of dust collecting systems and stock and refuse conveying systems, and were adopted by the NFPA at its Annual Meetings in 1946, 1947, 1948, and 1949. Editorially revised editions were published in 1959 and 1961. In 1972, Section 200 (Chapter 2) was expanded, and a new Section 500 (Chapter 5), covering systems involving plastic materials, was added. In the 1973 edition, Section 400 (Chapter 4) was completely revised. The 1983 edition was completely updated to conform with the NFPA *Manual of Style* and incorporated minor revisions in each chapter.

The 1990 edition included minor revisions to Chapter 2 including a new Figure 2-8 and Table 2-8(b). Changes were made to recognize NFPA 45, *Standard on Fire Protection for Laboratories Using Chemicals*, and to remove conflicts with that standard. These changes included moving Section 5-2 and Figures 5-2 through 5-5 to Appendix A.

The Technical Committee on Blower Systems completely revised the standard for the 1992 edition, including a new title and new scope. The previous title had been *Standard for the Installation of Blower and Exhaust Systems for Dust, Stock, and Vapor Removal or Conveying*. Chapters 3 and 4 from the 1990 edition were deleted with some requirements from those chapters included in the revised and reorganized Chapter 2 and new Chapters 5, 6, and 7.

Minor changes were made to all chapters in the 1995 edition. The Committee clarified their intent that ducts can be round, oval, or rectangular. A new figure was added to show access openings for different shapes of ducts, and a new table was added in the appendix to show duct velocities for types of materials conveyed.

The 1999 edition incorporated a new scope limiting the applicability of this document to noncombustible particulate solids. The Committee on Handling and Conveying of Dusts, Vapors, and Gases became responsible for NFPA 91 and made changes consistent with the committee's other documents, NFPA 650, *Standard for Pneumatic Conveying Systems for Handling Combustible Particulate Solids*, and NFPA 654, *Standard for the Prevention of Fire and Dust Explosions from the Manufacturing, Processing, and Handling of Combustible Particulate Solids*, that address combustible particulate solids.

In the 2004 revision, the Committee completed changes according to the *Manual of Style for NFPA Technical Committee Documents* and the conditions under which flammable concentrations can exceed 25 percent of the lower flammable limit (LFL) were expanded to match provisions in other NFPA documents. The design requirements for duct hanging and bracing and fire protection requirements for ducting were also updated.

The 2010 edition contains extensive revisions to Chapter 4 on exhaust system design and construction. These revisions bring requirements from the complementary document on pneumatic conveying systems, NFPA 654, to this standard for correlation and consistency. The Committee also added a new chapter on Air–Material Separators (Chapter 7) using concepts from NFPA 654. Chapter 9 has been revised to be made retroactive and to establish requirements for testing frequency. Other changes make the standard consistent with the *Manual of Style for NFPA Technical Committee Documents*.



Technical Committee on Handling and Conveying of Dusts, Vapors, and Gases

Walter L. Frank, *Chair*

Frank Risk Solutions, Inc., DE [SE]

Joe R. Barton, Fountaintown, IN [SE]

Walter S. Beattie, AXA Corporate Solutions/Matrix Risk Consultants, PA [I]

John M. Cholin, J. M. Cholin Consultants Inc., NJ [SE]

Vahid Ebadat, Chilworth Technology Inc., NJ [SE]

Henry L. Febo, Jr., FM Global, MA [I]

Henry W. Garzia, Kidde-Fenwal, Inc., MA [M]

Joseph P. Gillis, Westboro, MA [SE]

Dan A. Guaricci, ATEX Explosion Protection L.P., FL [M]

Paul F. Hart, XL Global Asset Protection Services, IL [I]

William C. Hilton, Georgia-Pacific, GA [U]

Mark L. Holcomb, Kimberly-Clark Corporation, WI [U]

Ray Hunter, Ray Hunter & Associates Inc., AL [M]

Rep. American Air Filter

Gregory I. Hurst, National Starch & Chemical Company, IN [U]

Jerry J. Jennett, Georgia Gulf Sulfur Corporation, GA [M]

David C. Kirby, Baker Engineering & Risk Consultants, WV [SE]

James F. Koch, The Dow Chemical Company, MI [U]

Rep. American Chemistry Council

Guillermo A. Navas, Sheet Metal & Air Conditioning Contractors National Assn., VA [M]

Jack E. Osborn, Airdusco, Inc., TN [M]

James L. Roberts, Fluor Enterprises, Inc., SC [SE]

Mark L. Runyon, Marsh USA Inc., OR [I]

Thomas C. Scherpa, E. I. duPont de Nemours & Company, MA [U]

Richard F. Schwab, Honeywell, Inc., NJ [U]

Thomas J. Slavin, Navistar International Corporation, IL [U]

Rep. American Foundry Society, Inc.

Bill Stevenson, CV Technology, Inc., FL [M]

Jeffrey W. Sutton, Global Risk Consultants Corporation, MN [SE]

Erdem A. Ural, Loss Prevention Science & Technologies, Inc., MA [SE]

Harold H. Weber, Jr., The Sulphur Institute, DC [U]
(Voting Limited to Document 655)

Alternates

Paul A. Cera, Marsh Risk Consulting, CT [I]

(Alt. to M. L. Runyon)

Brice Chastain, Georgia-Pacific, GA [U]

(Alt. to W. C. Hilton)

C. James Dahn, Safety Consulting Engineers Inc., IL [SE]

(Alt. to V. Ebadat)

Robert L. Gravell, E. I. duPont de Nemours & Company, Inc., NJ [U]

(Alt. to T. C. Scherpa)

Albert I. Ness, The Dow Chemical Company, PA [M]

(Alt. to C. J. F. Koch)

Samuel A. Rodgers, Honeywell, Inc., VA [U]

(Alt. to R. F. Schwab)

Nonvoting

Matthew I. Chibbaro, U.S. Department of Labor, DC [E]

William R. Hamilton, U.S. Department of Labor, DC [E]

Harry Verakis, U.S. Department of Labor, WV [E]

Jeffrey J. Wanko, U.S. Chemical Safety & Hazard Investigation Board, DC [SE]

Guy R. Colonna, NFPA Staff Liaison

This list represents the membership at the time the Committee was balloted on the final text of this edition. Since that time, changes in the membership may have occurred. A key to classifications is found at the back of the document.

NOTE: Membership on a committee shall not in and of itself constitute an endorsement of the Association or any document developed by the committee on which the member serves.

Committee Scope: This Committee shall have primary responsibility for documents on the prevention, control, and extinguishment of fires and explosions in the design, construction, installation, operation, and maintenance of facilities and systems processing or conveying flammable or combustible dusts, gases, vapors, and mists.

Contents

Chapter 1 Administration	91- 5	Chapter 7 Air-Material Separators (Air Separation Devices)	91-11
1.1 Scope	91- 5	7.1 General Requirements	91-11
1.2 Purpose	91- 5	7.2 Separators for Noncombustible Particulates	91-11
1.3 Retroactivity	91- 5	7.3 Separators for Flammable Gases, Vapors, and Mists	91-11
1.4 Equivalency	91- 5		
Chapter 2 Referenced Publications	91- 5	Chapter 8 Ignition Sources	91-11
2.1 General	91- 5	8.1 Electrical Equipment	91-11
2.2 NFPA Publications	91- 5	8.2 Static Electricity	91-11
2.3 Other Publications	91- 5	8.3 Manifolds	91-11
2.4 References for Extracts in Mandatory Sections	91- 6	8.4 Open Flames and Sparks	91-12
		8.5 Removal of Ferrous Materials	91-12
Chapter 3 Definitions	91- 6	8.6 Belt Drives	91-12
3.1 General	91- 6	8.7 Bearings	91-12
3.2 NFPA Official Definitions	91- 6	8.8 Equipment	91-12
3.3 General Definitions	91- 6		
Chapter 4 Design and Construction	91- 6	Chapter 9 Fire Protection	91-12
4.1 General Requirements	91- 6	9.1 General	91-12
4.2 Duct Material and Construction	91- 7	9.2 Drainage	91-12
4.3 Access	91- 8	9.3 Testing and Inspection	91-12
4.4 Design Requirements	91- 8		
4.5 Hangers and Supports	91- 8	Chapter 10 Testing and Maintenance	91-12
4.6 Duct Installation	91- 8	10.1 Retroactivity	91-12
		10.2 General	91-12
Chapter 5 Corrosive Materials	91-10	10.3 System Test	91-12
5.1 General	91-10	10.4 System Inspection	91-12
		10.5 Cleanliness	91-13
Chapter 6 Air-Moving Devices	91-10	10.6 Maintenance Program	91-13
6.1 General	91-10	10.7 Maintenance Log	91-13
6.2 Flammable or Combustible Materials	91-10		
6.3 Clearance	91-10	Annex A Explanatory Material	91-13
6.4 Alignment	91-10		
6.5 Maintenance and Inspection	91-11	Annex B Informational References	91-16
6.6 Location	91-11		
6.7 Flexible Connections	91-11	Index	91-18



NFPA 91**Standard for****Exhaust Systems for Air Conveying of Vapors,
Gases, Mists, and Noncombustible Particulate
Solids****2010 Edition**

IMPORTANT NOTE: This NFPA document is made available for use subject to important notices and legal disclaimers. These notices and disclaimers appear in all publications containing this document and may be found under the heading "Important Notices and Disclaimers Concerning NFPA Documents." They can also be obtained on request from NFPA or viewed at www.nfpa.org/disclaimers.

NOTICE: An asterisk (*) following the number or letter designating a paragraph indicates that explanatory material on the paragraph can be found in Annex A.

Changes other than editorial are indicated by a vertical rule beside the paragraph, table, or figure in which the change occurred. These rules are included as an aid to the user in identifying changes from the previous edition. Where one or more complete paragraphs have been deleted, the deletion is indicated by a bullet (•) between the paragraphs that remain.

A reference in brackets [] following a section or paragraph indicates material that has been extracted from another NFPA document. As an aid to the user, the complete title and edition of the source documents for extracts in mandatory sections of the document are given in Chapter 2 and those for extracts in informational sections are given in Annex B. Extracted text may be edited for consistency and style and may include the revision of internal paragraph references and other references as appropriate. Requests for interpretations or revisions of extracted text shall be sent to the technical committee responsible for the source document.

Information on referenced publications can be found in Chapter 2 and Annex B.

Chapter 1 Administration**1.1* Scope.**

1.1.1 This standard provides minimum requirements for the design, construction, installation, operation, testing, and maintenance of exhaust systems for air conveying of vapors, gases, mists, and noncombustible particulate solids as they relate to fire and/or explosion prevention, except as modified or amplified by other applicable NFPA standards.

1.1.2 This standard does not cover exhaust systems for conveying combustible particulate solids that are covered in other NFPA standards (see A.1.1).

1.2 Purpose. The purpose of this standard is to provide technical requirements for exhaust systems that will achieve the following results:

- (1) Provide safety to life and property from fires and explosions
- (2) Minimize the damage in the event that such fires and explosions occur

1.3 Retroactivity. The provisions of this standard reflect a consensus of what is necessary to provide an acceptable degree of protection from the hazards addressed in this standard at the time the standard was issued.

1.3.1 Unless otherwise specified, the provisions of this standard shall not apply to facilities, equipment, structures, or installations that existed or were approved for construction or installation prior to the effective date of the standard. Where specified, the provisions of this standard shall be retroactive.

1.3.2 In those cases where the authority having jurisdiction determines that the existing situation presents an unacceptable degree of risk, the authority having jurisdiction shall be permitted to apply retroactively any portions of this standard deemed appropriate.

1.3.3 The retroactive requirements of this standard shall be permitted to be modified if their application clearly would be impractical in the judgment of the authority having jurisdiction, and only where it is clearly evident that a reasonable degree of safety is provided.

1.4 Equivalency. Nothing in this standard is intended to prevent the use of systems, methods, or devices of equivalent or superior quality, strength, fire resistance, effectiveness, durability, and safety over those prescribed by this standard.

1.4.1 Technical documentation shall be submitted to the authority having jurisdiction to demonstrate equivalency.

1.4.2 The system, method, or device shall be approved for the intended purpose by the authority having jurisdiction.

Chapter 2 Referenced Publications

2.1 General. The documents or portions thereof listed in this chapter are referenced within this standard and shall be considered part of the requirements of this document.

2.2 NFPA Publications. National Fire Protection Association, 1 Batterymarch Park, Quincy, MA 02169-7471.

NFPA 25, *Standard for the Inspection, Testing, and Maintenance of Water-Based Fire Protection Systems*, 2008 edition.

NFPA 51B, *Standard for Fire Prevention During Welding, Cutting, and Other Hot Work*, 2009 edition.

NFPA 68, *Standard on Explosion Protection by Deflagration Venting*, 2007 edition.

NFPA 69, *Standard on Explosion Prevention Systems*, 2008 edition.

NFPA 70®, *National Electrical Code*®, 2008 edition.

NFPA 86, *Standard for Ovens and Furnaces*, 2007 edition.

NFPA 221, *Standard for High Challenge Fire Walls, Fire Walls, and Fire Barrier Walls*, 2009 edition.

NFPA 259, *Standard Test Method for Potential Heat of Building Materials*, 2008 edition.

NFPA 780, *Standard for the Installation of Lightning Protection Systems*, 2008 edition.

2.3 Other Publications.

2.3.1 SMACNA Publications. Sheet Metal and Air Conditioning Contractors' National Association, 4201 Lafayette Center Drive, Chantilly, VA 20151-1209.

Accepted Industry Practice for Industrial Duct Construction, 1975.

Rectangular Industrial Duct Construction Standard, 2004.

Round Industrial Duct Construction Standard, 1999.

Thermoplastic Duct (PVC) Construction Manual, 2nd edition, 1995.

Thermoset FRP Duct Construction Manual, 1997.

2.3.2 Other Publications.

Merriam-Webster's Collegiate Dictionary, 11th edition, Merriam-Webster, Inc., Springfield, MA, 2003.

2.4 References for Extracts in Mandatory Sections.

NFPA 33, *Standard for Spray Application Using Flammable or Combustible Materials*, 2007 edition.

NFPA 329, *Recommended Practice for Handling Releases of Flammable and Combustible Liquids and Gases*, 2010 edition.

NFPA 654, *Standard for the Prevention of Fire and Dust Explosions from the Manufacturing, Processing, and Handling of Combustible Particulate Solids*, 2006 edition.

Chapter 3 Definitions

3.1 General. The definitions contained in this chapter shall apply to the terms used in this standard. Where terms are not defined in this chapter or within another chapter, they shall be defined using their ordinarily accepted meanings within the context in which they are used. *Merriam-Webster's Collegiate Dictionary*, 11th edition, shall be the source for the ordinarily accepted meaning.

3.2 NFPA Official Definitions.

3.2.1* Approved. Acceptable to the authority having jurisdiction.

3.2.2* Authority Having Jurisdiction (AHJ). An organization, office, or individual responsible for enforcing the requirements of a code or standard, or for approving equipment, materials, an installation, or a procedure.

3.2.3 Labeled. Equipment or materials to which has been attached a label, symbol, or other identifying mark of an organization that is acceptable to the authority having jurisdiction and concerned with product evaluation, that maintains periodic inspection of production of labeled equipment or materials, and by whose labeling the manufacturer indicates compliance with appropriate standards or performance in a specified manner.

3.2.4* Listed. Equipment, materials, or services included in a list published by an organization that is acceptable to the authority having jurisdiction and concerned with evaluation of products or services, that maintains periodic inspection of production of listed equipment or materials or periodic evaluation of services, and whose listing states that either the equipment, material, or service meets appropriate designated standards or has been tested and found suitable for a specified purpose.

3.2.5 Shall. Indicates a mandatory requirement.

3.3 General Definitions.

3.3.1* Air-Material Separator (AMS). A collector designed to separate the conveying air from the material being conveyed. [654, 2006]

3.3.2* Air-Moving Device. A fan, blower, or other device that establishes an airflow by moving a volume of air per unit time.

3.3.3 Duct. Pipes, tubes, or other enclosures used for the purpose of pneumatically conveying materials.

3.3.4* Exhaust System. An air-conveying system for moving materials from a source to a point of discharge.

3.3.5* Explosion Hazard. In the context of this standard, an explosion hazard is a volume within the exhaust system that contains a combustible or flammable material at concentrations greater than 25 percent of the relevant lower flammable limit (LFL) at any time during startup, operation, shutdown, maintenance, or process upset.

3.3.6 Fire Barrier. A continuous membrane, either vertical or horizontal, such as a wall or floor assembly, that is designed and constructed with a specified resistance rating to limit the spread of fire and that will also restrict the movement of smoke. Such barriers may have protected openings.

3.3.7 Fire Damper. A device installed in an exhaust system designed to close automatically upon detection of heat to interrupt air flow and to restrict the passage of flame.

3.3.8 Limited Combustible. A building construction material not complying with the definition of noncombustible material that, in the form in which it is used, has a potential heat value not exceeding 8140 kJ/kg (3500 Btu/lb), where tested in accordance with NFPA 259, *Standard Test Method for Potential Heat of Building Materials*, and complies with (a) or (b): (a) materials having a structural base of noncombustible material, with a surfacing not exceeding a thickness of 3 mm (1/8 in.) that has a flame spread index not greater than 50; and (b) materials, in the form and thickness used, other than as described in (a), having neither a flame spread index greater than 25 nor evidence of continued progressive combustion and of such composition that surfaces that would be exposed by cutting through the material on any plane would have neither a flame spread index greater than 25 nor evidence of continued progressive combustion. (Materials subject to increase in combustibility or flame spread index beyond the limits herein established through the effects of age, moisture, or other atmospheric condition shall be considered combustible.) [33, 2007]

3.3.9* Lower Flammable Limit (LFL). That concentration of a combustible material in air below which ignition will not occur. Also known as the lower explosive limit (LEL). [329, 2010]

3.3.10* Noncombustible Material. A material that, in the form in which it is used and under the conditions anticipated, will not ignite, burn, support combustion, or release flammable vapors when subjected to fire or heat.

3.3.11* Noncombustible Particulate Solid. Any noncombustible solid material composed of distinct particles or pieces, regardless of size, shape, or chemical composition.

Chapter 4 Design and Construction

4.1 General Requirements.

4.1.1* The design and installation of exhaust systems shall be the responsibility of persons having a knowledge of these systems.

4.1.2* Incompatible materials shall not be conveyed in the same system.



4.1.3 Unless the circumstances stipulated in 4.1.3.1, 4.1.3.2, or 4.1.3.3 exist, in systems conveying flammable vapors, gases, or mists, the concentration shall not exceed 25 percent of the LFL.

4.1.3.1 Higher concentrations shall be permitted if the exhaust system is designed and protected in accordance with NFPA 69, *Standard on Explosion Prevention Systems*, using one or more of the following techniques:

- (1) Combustible concentration reduction
- (2) Oxidant concentration reduction
- (3) Deflagration suppression
- (4) Deflagration pressure containment

4.1.3.2 Higher concentrations shall be permitted for ovens and furnaces designed and protected in accordance with NFPA 86, *Standard for Ovens and Furnaces*.

4.1.3.3 Higher concentrations shall be permitted where deflagration venting is provided in accordance with NFPA 68, *Standard on Explosion Protection by Deflagration Venting*.

4.1.4 The design of any exhaust system shall require knowledge of the physical and chemical properties and hazardous characteristics of the materials being conveyed.

4.1.5* Air-moving devices shall be sized to establish the velocity required to capture, control, and convey materials through the exhaust system.

4.1.6 Operations generating flames, sparks, or hot material such as from grinding wheels and welding shall not be manifolded into any exhaust system that air conveys flammable or combustible materials.

4.1.7 Magnetic Separations. Where required, magnetic separators shall be installed in accordance with Section 8.5.

4.1.8* System Plans.

4.1.8.1 Plans and specifications for new systems and systems to be modified shall be submitted to the authority having jurisdiction for approval prior to installation or modification.

4.1.8.2 The submittal shall provide information adequate to describe the hazard and to demonstrate safe performance of the system.

4.1.9 Fire dampers shall be permitted to be installed in exhaust systems in the following situations:

- (1) Where ducts pass through fire barriers
- (2) Where a collection system installed on the end of the system is protected with an automatic extinguishing system
- (3) Where the duct system is protected with an automatic extinguishing system
- (4) Where ducts have been listed with interrupters
- (5) Where necessary to facilitate the control of smoke pursuant to the applicable NFPA standards

4.1.10 Fire dampers shall not be installed if the material being exhausted is toxic and if a risk evaluation indicates that the toxic hazard is greater than the fire hazard.

4.1.11 Exhaust ducts shall not pass through fire walls, as defined by NFPA 221, *Standard for High Challenge Fire Walls, Fire Walls, and Fire Barrier Walls*.

4.1.12 Exhaust ducts passing through a fire barrier having a fire resistance rating of 2 hours or greater shall meet either of the following specifications:

- (1) Wrapped or encased with listed or approved materials having a fire resistance rating equal to the fire barrier for 3 m (10 ft) of the duct on each side of the fire barrier including duct supports within this span
- (2) Constructed of materials and supports having a minimum fire resistance rating equal to the fire barrier

4.1.13 Exhaust ducts passing through fire barriers of any fire resistance rating shall be protected by sealing the space around the duct with listed or approved fire stopping having a fire resistance rating equal to the fire resistance rating of the fire barrier.

4.1.14 Unless the circumstances stipulated in 4.1.14.1 or 4.1.14.2 exist, fire detection and alarm systems shall not be interlocked to shut down air-moving devices.

4.1.14.1 Where shutdown is necessary for the effective operation of an automatic extinguishing system, it shall be permitted to interlock fire detection and alarm systems to shut down air-moving devices.

4.1.14.2 Where a documented risk analysis acceptable to the authority having jurisdiction shows that the risk of damage from fire and the products of combustion would be higher with air-moving devices operating, it shall be permitted to interlock fire detection and alarm systems to shut down air-moving devices.

4.2 Duct Material and Construction.

4.2.1 Unless the circumstances stipulated in 4.2.1.1 or 4.2.1.2 exist, duct material shall be noncombustible.

4.2.1.1 Combustible duct material, when protected in accordance with Chapter 9, shall be permitted to be used when the material being conveyed is incompatible with noncombustible construction materials.

4.2.1.2 Listed duct systems approved for use without automatic fire protection and not subject to combustible residue buildup shall be permitted to be used.

4.2.2 The duct construction shall conform to the following applicable Sheet Metal and Air Conditioning Contractors' National Association (SMACNA) standards:

- (1) *Accepted Industry Practice for Industrial Duct Construction*
- (2) *Rectangular Industrial Duct Construction Standard*
- (3) *Round Industrial Duct Construction Standard*
- (4) *Thermoplastic Duct (PVC) Construction Manual*
- (5) *Thermoset FRP Duct Construction Manual*

4.2.3 Duct supports shall be designed to carry the weight of the duct system itself plus the anticipated weight of any conveyed materials.

4.2.4 If sprinkler protection is provided inside the duct system, then the duct supports shall also be designed to carry the anticipated weight of any accumulation of sprinkler discharge.

4.2.5 Laps in duct construction shall be in the direction of airflow.

4.2.6 Condensate.

4.2.6.1 Joints in duct construction shall be liquidtight when the conveying system contains condensable vapors or liquids in suspension.

4.2.6.2 Provisions shall be made for drainage of condensate at low points in the duct.

4.3 Access.

4.3.1* A means shall be provided to inspect the system in accordance with Section 10.3.

4.3.2 The requirement of 4.3.1 shall not apply to ducts handling materials that do not create a condition requiring access into the duct.

4.3.3 Location and Size.

4.3.3.1 Access openings shall be located and sized to satisfy their intended purpose.

4.3.3.2 Where used, access openings shall be located on the tops or sides of the ducts.

4.3.4* Where access openings are used, the closures shall maintain the integrity of the duct system.

4.3.5 Where used, required openings or other penetrations shall be sealed, gasketed, or tightly fitted so that conveyed material does not escape.

4.4 Design Requirements.

4.4.1* An exhaust system shall be inherently balanced, or a means shall be provided for balancing the system.

4.4.2 Where used, balancing devices shall be secured to prevent inadvertent adjustment or loss of transport velocity.

4.4.3 When dampers or louvers are used for weather or back-draft protection, they shall be located on the clean-air side of the filtration system.

4.4.4* Building components shall not be used as parts of a duct system.

4.4.5* Discharge shall terminate away from outside air intakes to prevent material from entering the air intakes.

4.4.6 The rate of airflow at each hood or other pickup point shall be designed so as to capture, convey, and control the material. [654:7.3.2.3]

4.4.7* All ductwork shall be sized to provide the air volume and air velocity necessary to keep the duct interior clean and free of residual material. [654:7.3.2.4]

4.4.8 Hoods.

4.4.8.1 Materials shall be confined to and removed from the area where they are generated, by hoods or enclosures and an air-moving device.

4.4.8.2* When it is not possible for the process to be enclosed or hoods installed, local exhaust ventilation shall be permitted.

4.4.9 Duct liners that are combustible shall meet one of the following requirements:

- (1) They shall be tested as part of a listed duct system that has been evaluated and found to be of low fire hazard not requiring automatic sprinkler protection to prevent fire spread.
- (2) They shall have automatic sprinkler protection as required by Chapter 9.

4.4.10 Additional branch ducts shall not be added to an existing system without redesign of the system.

4.4.11 Branch ducts shall not be disconnected nor unused portions of the system be blanked off without provision for means to maintain required airflow.

4.4.12 Flexible ducts shall be permitted to be used only at inlets where movability or portability is required.

4.5 Hangers and Supports.

4.5.1 Duct supports shall be designed to carry the weight of the duct half filled with material.

4.5.2 Where sprinkler protection is provided or cleaning of the duct will be performed, the hanger's design shall include the weight of any expected liquid accumulation.

4.5.3 Duct supports shall be designed to prevent placing loads on connected equipment.

4.5.4 Hangers and supports exposed to corrosive atmospheres shall be resistant to the corrosive atmospheres.

4.5.5 To avoid vibration and stress on the duct, hangers and supports shall be securely fastened to the building or structure.

4.5.6 Hangers and supports shall be designed to allow for expansion and contraction.

4.6 Duct Installation.

4.6.1 General Requirements. Unless the conditions stipulated in 4.6.1.1 or 4.6.2 exist, all duct systems and system components shall have a clearance of at least 6 in. (152 mm) from stored combustible materials, and not less than ½ in. (13 mm) clearance from combustible construction.

4.6.1.1 Where stored combustible material or combustible construction is protected from ductwork by the use of materials or products listed for protection purposes, clearance shall be maintained in accordance with those listings.

4.6.2 Systems Conveying Combustible Materials. Unless the conditions stipulated in 4.6.2.1 exist, all duct systems and system components handling combustible materials shall have a clearance of not less than 18 in. (457 mm) from stored combustible materials or combustible construction.

4.6.2.1 When the ductwork system is operating at 140°F (60°C) or below and is equipped with an approved automatic extinguishing system designed for the specific hazard, the clearance shall be permitted to be reduced to 6 in. (152 mm) from combustible materials and ½ in. (13 mm) from combustible construction.

4.6.3 Clearance Increases. All duct systems and system components operating at temperatures above 140°F (60°C) shall have clearances from stored combustible materials or combustible construction not less than those listed in Table 4.6.3.

4.6.3.1 Ducts handling materials at temperatures in excess of 900°F (482°C) shall be lined with refractory material or the equivalent.

4.6.3.2 When stored combustible materials or combustible construction are protected from ductwork in accordance with 4.6.4, the clearance established in Table 4.6.3 shall be permitted to be reduced in accordance with Table 4.6.4, but not to less than specified in 4.6.1.

4.6.4 Clearance Reduction Methods. It shall be permitted to protect stored combustible material or combustible construction from ductwork in accordance with Table 4.6.4 and this section.



Table 4.6.3 Basic Minimum Clearances to Unprotected Surfaces

Duct Gas Temperature	Largest Duct Dimension		Clearance	
	in.	mm	in.	mm
140°F–600°F (60°C–315°C) incl.	8	203	8	203
	>8	>203	12	305
>600°F–900°F (>315°C–482°C) incl.	8	203	18	457
	>8	>203	24	610
>900°F (>482°C)	All ducts lined with refractory		24	610

Table 4.6.4 Reduction of Duct Clearance with Specified Forms of Protection

Form of Protection*	Maximum Allowable Reduction in Clearance (%)	
	As Wall Protector or Vertical Surface	As Ceiling Protector or Horizontal Surface
3½ in. (90 mm) thick masonry wall without ventilated air space	33	None
½ in. (13 mm) thick noncombustible insulation board over 1 in. (25.4 mm) glass fiber or mineral wool batts without ventilated air space	50	33
0.024 in. (0.61 mm/24 gauge) sheet metal over 1 in. (25.4 mm) glass fiber or mineral wool batts reinforced with wire, or equivalent on rear face with at least a 1 in. (25.4 mm) air gap	66	66
3½ in. (90 mm) thick masonry wall with at least a 1 in. (25.4 mm) air gap	66	None
0.024 in. (0.61 mm/24 gauge) sheet metal with at least a 1 in. (25.4 mm) air gap	66	50
½ in. (13 mm) thick noncombustible insulation board with at least a 1 in. (25.4 mm) air gap	66	50
0.024 in. (0.61 mm/24 gauge) sheet metal with ventilated air space over at least 0.024 in. (0.61 mm/24 gauge) sheet metal with at least a 1 in. (25.4 mm) air gap	66	50
1 in. (25.4 mm) glass fiber or mineral wool batts sandwiched between two sheets of 0.024 in. (0.61 mm/24 gauge) sheet metal with at least a 1 in. (25.4) mm air gap	66	50

* Clearance reduction applied to and covering all combustible surfaces within the distance specified as required clearance with no protection in Table 4.6.3.

4.6.4.1 In no case shall the clearance between the duct and the combustible surface be reduced below that allowed in Table 4.6.4.

4.6.4.2 Spacers and ties for protection materials shall be of noncombustible material and shall not be installed on the duct side of the protection system.

4.6.4.3 Mineral wool batts (blanket or board) shall have a minimum density of 8 lb/ft³ (130 kg/m³) and have a minimum melting point of 1500°F (816°C).

4.6.4.4 Insulation board used as a part of a clearance reduction system shall meet the following criteria:

- (1) Have a thermal conductivity of 1 Btu in./ft² hr °F (0.14 W/m² hr °C) or less
- (2) Be formed of noncombustible material

4.6.4.5 With all clearance reduction systems, at least 1 in. (25.4 mm) clear space shall be provided between the duct and the thermal shield.

4.6.4.6 When using clearance reduction systems that include an air gap, at least 1 in. (25.4 mm) clear space shall be provided between the thermal shield and the combustible surface.

4.6.4.7 When using clearance reduction systems that include an air gap between the combustible surface and the selected means of protection, air circulation shall be provided by one of the methods in 4.6.4.7.1 through 4.6.4.7.3.

4.6.4.7.1 Air circulation shall be permitted to be provided by leaving all edges of the protecting system open with at least a 1 in. (25.4 mm) air gap.

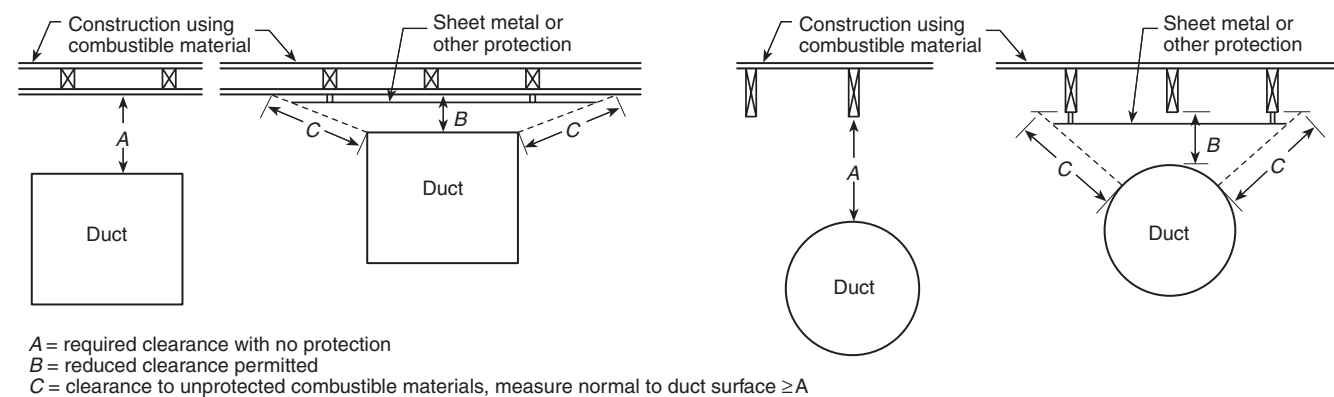

FIGURE 4.6.5.1 Extent of Protection Required to Reduce Clearances from Ducts.

4.6.4.7.2 If the means of protection is mounted on a single flat wall away from corners, air circulation shall be permitted to be provided by one of the following:

- (1) Leaving only the top and bottom edges open to circulation by maintaining the 1 in. (25.4 mm) air gap
- (2) Leaving the top and both side edges open to circulation by maintaining the 1 in. (25.4 mm) air gap

4.6.4.7.3 Thermal shielding that covers two walls in a corner shall be permitted to be open at the top and bottom edges with at least a 1 in. (25.4 mm) air gap.

4.6.5 Measuring Clearances.

4.6.5.1 As shown in Figure 4.6.5.1, all clearances shall be measured from the outer surface of the combustible material to the nearest point on the outer surface of the duct, disregarding any intervening protection over the combustible material.

4.6.5.2 The minimum allowable clearance with protection provided, shown as dimension B in Figure 4.6.5.1, shall be calculated by using the following equation:

$$B = A \cdot \left(1 - \frac{R}{100} \right)$$

where:

- B = minimum allowable clearance with protection
 A = required clearance with no protection
 R = maximum allowable clearance reduction in %

4.6.5.3 The protection applied to the construction using noncombustible materials shall extend far enough in each direction to make distance C in Figure 4.6.5.1, at least equal to the required clearance with no protection A.

Chapter 5 Corrosive Materials

5.1 General.

5.1.1 Exhaust systems utilizing plastic material shall be permitted to be used to convey nonflammable corrosives.

5.1.2 The choice of the material type shall be the responsibility of the design engineer.

5.1.3* All chemical-resistant plastics have properties and limitations that shall be considered in the design of a system.

5.1.4 The minimum standards of materials, construction, and workmanship in 5.1.4.1 through 5.1.4.3 shall be deemed necessary to ensure minimum fire hazard in the operation of these systems.

5.1.4.1 Plastic ducts shall be in accordance with 4.2.1 and 4.4.9.

5.1.4.2 All hoods and air-moving device surfaces that are part of the system shall have flame spread ratings at least equivalent to the flame spread rating of the material of the duct system.

5.1.4.3 Where located in a multistory building or a concealed space, plastic duct materials shall be listed with an external smoke development rating of 50 or less, unless the duct system is located in an area protected by an automatic sprinkler system, or located in a 1-hour fire-rated enclosure.

Chapter 6 Air-Moving Devices

6.1 General.

6.1.1 Air-moving devices shall be constructed of noncombustible materials and shall be designed and installed to safely convey materials through the exhaust system.

6.1.2 Where the materials conveyed are not compatible with noncombustible materials, alternate materials of construction shall be permitted based upon a documented risk evaluation.

6.2 Flammable or Combustible Materials. Where flammable or combustible materials are conveyed at concentrations greater than 1 percent of the LFL, the rotating element of the air-moving device shall be nonferrous, or the air-moving device shall be constructed so that a shift of the rotating element or shaft does not permit two ferrous parts to rub or strike.

6.3 Clearance.

6.3.1 Clearance between the rotating element and the casing shall be provided to avoid friction that might lead to fire.

6.3.2 Allowances shall be made for expansion and loading to prevent contact between moving parts and the duct or housing.

6.4 Alignment. The rotating elements shall be mounted on a shaft designed to maintain proper alignment even when the blades or impeller are loaded.

6.5 Maintenance and Inspection.

6.5.1 Air-moving devices shall be located to permit ready access for inspection, lubrication, maintenance, cleaning, and repair.

6.5.2 Air-moving devices shall be placed on foundations or firmly secured to supports.

6.6 Location. Air-moving devices used in systems that air convey dust or vapors containing residue shall be located on the clean-air side of the filtration system.

6.7 Flexible Connections. Flexible connections shall be permitted in order to minimize the transmission of vibration.

Chapter 7 Air–Material Separators (Air Separation Devices)

7.1 General Requirements.

7.1.1 Air–material separators handling both noncombustible particulates as well as a flammable gas, vapor, or mist shall comply with the requirements of all relevant sections in this chapter.

7.1.2 The discharge system shall be designed to handle the maximum material flow attainable from the system.

7.1.3 Air–material separators shall be sized and selected to assure adequate system air flow under all anticipated design conditions.

7.1.4* All air–material separators shall be equipped with performance monitoring devices for verification of system performance per 7.1.2 and 7.1.3.

7.1.5 Materials of construction of the air–material separator shall not exceed the fire load for which the building compartment fire protection has been designed.

7.1.6 Location.

7.1.6.1 Where an explosion hazard exists within the air–material separator, air–material separators shall be located outside of buildings.

7.1.6.2 The requirement of 7.1.6.1 shall not apply to the following:

- (1) Air–material separators equipped with explosion venting in accordance with NFPA 68, *Standard on Explosion Protection by Deflagration Venting*
- (2) Air–material separators equipped with explosion protection in accordance with NFPA 69, *Standard on Explosion Prevention Systems*
- (3) Air–material separators with volumes less than 8 ft³ (0.2 m³)

7.1.7 Protection.

7.1.7.1 Where both an explosion hazard and a fire hazard exist in an air–material separator, provisions for protection for each type of hazard shall be provided.

7.1.7.2 The protection to be provided shall be permitted to be determined by a documented risk evaluation acceptable to the authority having jurisdiction.

7.1.8 Access. Access openings shall comply with Section 4.3.

7.1.9 Manifolding of Ducts. Where an explosion hazard exists, the requirements in 7.1.9.1 through 7.1.10 shall apply.

7.1.9.1 Manifolding of ducts to air–material separators shall not be permitted.

7.1.9.2 Ducts from a single piece of equipment or from multiple pieces of equipment interconnected on the same process stream shall be permitted to be manifolded.

7.1.9.3 Ducts from nonassociated pieces of equipment shall be permitted to be manifolded provided that each duct is equipped with an isolation device prior to manifolding in accordance with NFPA 69, *Standard on Explosion Prevention Systems*.

7.1.9.4 Ducts for centralized vacuum cleaning systems shall be permitted to be manifolded.

7.1.10 Where lightning protection is provided, it shall be installed in accordance with NFPA 780, *Standard for the Installation of Lightning Protection Systems*.

7.2* Separators for Noncombustible Particulates.

7.2.1* Hopper bottoms shall be designed with a slope suitable for the material being collected.

7.2.2* The type of air–material separator shall be suitable for the particulates to be separated.

7.3 Separators for Flammable Gases, Vapors, and Mists.

7.3.1* The type of separator shall be suitable for the gas, vapor, or mist being separated from the air stream.

7.3.2 A means shall be in place to determine when the media must be replaced in order to provide suitable removal of the filtrate.

7.3.3 Where the conveying gas includes flammable gases or vapors in addition to the noncombustible particulates, air–material separators shall be constructed of noncombustible materials.

7.3.4 Filter media and filter media support frames shall be permitted to be constructed of combustible material.

7.3.5 All system components shall be conductive.

7.3.6 Nonconductive system components shall be permitted where a documented risk evaluation has determined the level of risk from electrostatic ignition and the risk evaluation is acceptable to the authority having jurisdiction.

Chapter 8 Ignition Sources

8.1 Electrical Equipment. All electrical equipment and installations shall comply with the requirements of NFPA 70, *National Electrical Code*.

8.2* Static Electricity.

8.2.1 All system components shall be conductive.

8.2.2* Bonding and grounding with a resistance of less than 1.0×10^6 ohms to ground shall be provided.

8.2.3* Nonconductive equipment shall be permitted to be used in accordance with the requirements of Chapter 5.

8.2.4 Where belt drives are used, the belts shall be electrically conductive with a resistance of 1 megohm or less.

8.3 Manifolds. Operations generating flames, sparks, or hot material such as from grinding wheels and welding shall not

be manifolded into any exhaust system that air conveys flammable or combustible materials.

8.4 Open Flames and Sparks. The requirements of 8.4.1 through 8.4.3 shall be applied retroactively.

8.4.1 Cutting and welding shall comply with the applicable requirements of NFPA 51B, *Standard for Fire Prevention During Welding, Cutting, and Other Hot Work*.

8.4.2 Grinding, chipping, and other operations that produce either sparks or open flame ignition sources shall be controlled by a hot work permit system in accordance with NFPA 51B, *Standard for Fire Prevention During Welding, Cutting, and Other Hot Work*.

8.4.3 Smoking shall be permitted only in designated areas.

8.5 Removal of Ferrous Materials.

8.5.1* Ferrous materials capable of igniting combustible material being conveyed shall be removed from the exhaust stream by magnetic separators of the permanent or electromagnetic type.

8.5.2 Where electromagnetic separators are used, provisions shall be made to indicate the loss of power to the electromagnetic separators.

8.5.3 Where electromagnetic separators are used, they shall be listed or approved.

8.6* Belt Drives. Belt drives shall be designed to stall without the belt slipping, or a safety device shall be provided to shut down the equipment if slippage occurs.

8.7* Bearings.

8.7.1 Roller or ball bearings shall be used on all processing and transfer equipment.

8.7.2 Bearings and drive components shall not be placed inside ducts unless they are protected or enclosed to prevent ignition of flammable materials.

8.7.3 Lubrication shall be performed in accordance with the manufacturer's recommendations.

8.7.4 Bushings shall be permitted to be used when an engineering evaluation shows that mechanical loads and speeds preclude ignition due to frictional heating.

8.8 Equipment. Equipment with moving parts shall be installed and maintained so that true alignment is maintained and clearance is provided to minimize friction.

Chapter 9 Fire Protection

9.1* General. Any portion of an exhaust system utilizing combustible components or having the potential for combustible residue buildup on the inside, where the duct cross-sectional area is greater than or equal to 75 in.² (480 cm²), shall be provided with an automatic extinguishing system within the duct and at the duct intake, hood, enclosure, or canopy, or shall be constructed of material listed for use without sprinkler protection.

9.2 Drainage. When a sprinkler system is installed, means shall be provided to prevent water accumulation in the duct or flow of water back to a process subject that could be damaged by water.

9.3 Testing and Inspection. Fire protection shall be tested and inspected in accordance with NFPA 25, *Standard for the Inspection, Testing, and Maintenance of Water-Based Fire Protection Systems*.

Chapter 10 Testing and Maintenance

10.1 Retroactivity. The requirements of Chapter 10 shall be applied retroactively.

10.2 General. Exhaust systems shall be tested, inspected, and maintained to ensure safe operating conditions.

10.2.1 The responsibility for maintenance shall be assigned to trained personnel who are capable of recognizing potential hazards.

10.2.2 Maintenance shall include the determination that special protection for duct systems is fully operable and that plant automatic sprinkler protection is in service.

10.3* System Test.

10.3.1 When installation of a new system is complete, the system shall be tested to demonstrate performance before acceptance by the user.

10.3.2 Modified systems shall be retested.

10.3.3 Test results shall be recorded and maintained for at least 2 years or two test cycles, whichever is greater.

10.3.4* Existing systems shall be tested annually by the user to demonstrate continued performance.

10.3.5 Where the manufacturer's requirements are more stringent or where conditions of service and documented past test results dictate, testing frequencies shall be permitted to be adjusted accordingly, but not to exceed every 2 years.

10.4* System Inspection.

10.4.1 All system components shall be inspected monthly.

10.4.2 When the manufacturer's requirements are more stringent or where conditions of service and documented past inspection results dictate, inspection frequencies shall be permitted to be adjusted accordingly, but not to exceed quarterly.

10.4.3 Inspection results shall be recorded and maintained for at least 2 years.

10.4.4 The user's operational and maintenance program shall include all of the manufacturer's listed procedures that are applicable to the equipment.

10.4.5 An operational and maintenance checklist shall be maintained.

10.4.6 Accumulations of conveyed materials and residues shall be removed from hoods and enclosures, ducts and fittings, and air-moving devices.

10.4.7 The ducts shall be checked for obstructions such as improperly adjusted dampers or shutters.

10.4.8 Filtration systems shall be inspected and filters cleaned or replaced as required.

10.4.9 Air-moving devices shall be inspected for belt tension and wear and lubrication.

10.4.10 Hoods and enclosures shall be inspected for proper confinement and removal of materials.



10.5 Cleanliness. Ductwork shall be examined periodically to determine adequacy of cleaning frequency.

10.6 Maintenance Program.

10.6.1 All system components shall be maintained in good operating condition.

10.6.2 A written maintenance program shall be established.

10.6.3 The program shall include any and all recommendations provided by the manufacturer.

10.6.4 All deficiencies found during testing and inspection shall be corrected.

10.6.5 Serious deficiencies shall require immediate attention.

10.7 Maintenance Log. An operational maintenance log shall be kept to document maintenance actions.

Annex A Explanatory Material

Annex A is not a part of the requirements of this NFPA document but is included for informational purposes only. This annex contains explanatory material, numbered to correspond with the applicable text paragraphs.

A.1.1 The following NFPA standards contain information on the application of exhaust systems to specific industries or operations:

- (1) NFPA 1, *Fire Code*
- (2) NFPA 30, *Flammable and Combustible Liquids Code*
- (3) NFPA 30B, *Code for the Manufacture and Storage of Aerosol Products*
- (4) NFPA 32, *Standard for Drycleaning Plants*
- (5) NFPA 33, *Standard for Spray Application Using Flammable or Combustible Materials*
- (6) NFPA 34, *Standard for Dipping and Coating Processes Using Flammable or Combustible Liquids*
- (7) NFPA 35, *Standard for the Manufacture of Organic Coatings*
- (8) NFPA 36, *Standard for Solvent Extraction Plants*
- (9) NFPA 45, *Standard on Fire Protection for Laboratories Using Chemicals*
- (10) NFPA 61, *Standard for the Prevention of Fires and Dust Explosions in Agricultural and Food Processing Facilities*
- (11) NFPA 68, *Standard on Explosion Protection by Deflagration Venting*
- (12) NFPA 85, *Boiler and Combustion Systems Hazards Code*
- (13) NFPA 86, *Standard for Ovens and Furnaces*
- (14) NFPA 92A, *Standard for Smoke-Control Systems Utilizing Barriers and Pressure Differences*
- (15) NFPA 92B, *Standard for Smoke Management Systems in Malls, Atria, and Large Spaces*
- (16) NFPA 96, *Standard for Ventilation Control and Fire Protection of Commercial Cooking Operations*
- (17) NFPA 120, *Standard for Fire Prevention and Control in Coal Mines*
- (18) NFPA 204, *Standard for Smoke and Heat Venting*
- (19) NFPA 211, *Standard for Chimneys, Fireplaces, Vents, and Solid Fuel-Burning Appliances*
- (20) NFPA 303, *Fire Protection Standard for Marinas and Boatyards*
- (21) NFPA 318, *Standard for the Protection of Semiconductor Fabrication Facilities*
- (22) NFPA 409, *Standard on Aircraft Hangars*
- (23) NFPA 484, *Standard for Combustible Metals*

- (24) NFPA 654, *Standard for the Prevention of Fire and Dust Explosions from the Manufacturing, Processing, and Handling of Combustible Particulate Solids*
- (25) NFPA 655, *Standard for Prevention of Sulfur Fires and Explosions*
- (26) NFPA 664, *Standard for the Prevention of Fires and Explosions in Wood Processing and Woodworking Facilities*
- (27) NFPA 801, *Standard for Fire Protection for Facilities Handling Radioactive Materials*

A.3.2.1 Approved. The National Fire Protection Association does not approve, inspect, or certify any installations, procedures, equipment, or materials; nor does it approve or evaluate testing laboratories. In determining the acceptability of installations, procedures, equipment, or materials, the authority having jurisdiction may base acceptance on compliance with NFPA or other appropriate standards. In the absence of such standards, said authority may require evidence of proper installation, procedure, or use. The authority having jurisdiction may also refer to the listings or labeling practices of an organization that is concerned with product evaluations and is thus in a position to determine compliance with appropriate standards for the current production of listed items.

A.3.2.2 Authority Having Jurisdiction (AHJ). The phrase “authority having jurisdiction,” or its acronym AHJ, is used in NFPA documents in a broad manner, since jurisdictions and approval agencies vary, as do their responsibilities. Where public safety is primary, the authority having jurisdiction may be a federal, state, local, or other regional department or individual such as a fire chief; fire marshal; chief of a fire prevention bureau, labor department, or health department; building official; electrical inspector; or others having statutory authority. For insurance purposes, an insurance inspection department, rating bureau, or other insurance company representative may be the authority having jurisdiction. In many circumstances, the property owner or his or her designated agent assumes the role of the authority having jurisdiction; at government installations, the commanding officer or departmental official may be the authority having jurisdiction.

A.3.2.4 Listed. The means for identifying listed equipment may vary for each organization concerned with product evaluation; some organizations do not recognize equipment as listed unless it is also labeled. The authority having jurisdiction should utilize the system employed by the listing organization to identify a listed product.

A.3.3.1 Air–Material Separator (AMS). Examples include cyclones, bag filter houses, scrubbers, demisters, and electrostatic precipitators.

A.3.3.2 Air-Moving Device. Air-moving devices include fans, centrifugal fans, or mixed-flow fans. These devices have previously been called blowers or exhausters. Air-moving devices also include steam ejectors and similar devices.

A.3.3.4 Exhaust System. A system can consist of an air-moving device with ducting, connected to the inlet, the discharge, or both. More complicated systems can include ductwork, an air-moving device, control dampers, an air–material separator, noise attenuation, and pollution control equipment.

A.3.3.5 Explosion Hazard. A mist of flammable or combustible liquids has deflagration characteristics that are analogous to dusts. The lower flammable limit for dispersed liquid mists varies with droplet size in a manner that is analogous to particle size for dusts. The determination of these deflagration characteristics is

complicated by droplet dispersion, coalescence, and settling. A typical LFL for a fine hydrocarbon mist is 40 g/m³ to 50 g/m³, which is approximately equal to the LFL for combustible hydrocarbon gases in air at room temperature. Mists of combustible liquids can be ignited at initial temperatures well below the flash point of the liquid. [68: B.2.6]

A.3.3.9 Lower Flammable Limit (LFL). Mixtures below this limit are said to be “too lean.” [329, 2010]

A.3.3.10 Noncombustible Material. Materials reported as passing ASTM E 136, *Standard Test Method for Behavior of Materials in a Vertical Tube Furnace at 750°C*, are considered noncombustible materials.

A.3.3.11 Noncombustible Particulate Solid. Noncombustible particulate solids include dusts, fibers, fines, chips, chunks, flakes, and mixtures of these.

A.4.1.1 Users should refer to the current *Industrial Ventilation — A Manual of Recommended Practice for Design* for the proper design of the system.

A.4.1.2 Materials, when mixed, should not create a fire, explosion, or health hazard.

A.4.1.5 Capture, control, and conveying of materials are achieved by inward airflow generated by the exhaust pickup or intake, the intake velocity, and the duct velocity.

Capture velocities should be high enough to maintain control of the material in order to accomplish the following:

- (1) Convey the material to the intake opening
- (2) Overcome thermal air currents from hot processes or heat-generating operations
- (3) Overcome air currents caused by grinding wheels and belt conveyors
- (4) Overcome air currents caused by dumping and filling operations
- (5) Overcome air currents caused by items such as pedestal fans and other personnel cooling or heating devices.

Exhaust systems designed for gases, vapors, fumes, and fine dust particles (20 microns or less) require intake velocities high enough to offset air currents caused by room cross-drafts.

Duct velocities are determined by the type of material conveyed (see Table A.4.1.5).

The designer also must consider sticky or wet residues or particles, electrostatic effects, and so forth.

For further information, refer to *Industrial Ventilation — A Manual of Recommended Practice for Design*, published by the American Conference of Governmental Industrial Hygienists (ACGIH).

A.4.1.8 The design of the exhaust system should be coordinated with the architectural and structural designs. The plans and specifications should include a list of all equipment, giving manufacturer and type number. Plans should be drawn to an indicated scale and show all essential details as to location, construction, ventilation ductwork, volume of outside air at standard temperature and pressure introduced for safety ventilation, and control wiring diagrams. The details of the plan should also include the following:

- (1) Name of owner and occupant
- (2) Location, including street address
- (3) Point of compass
- (4) Ceiling construction
- (5) Full height cross-section

- (6) Location of fire walls
- (7) Location of partitions
- (8) Materials of duct construction

A.4.3.1 Access into ducts is required to perform intended inspection, to clean interior surfaces, and to service or replace devices located inside the duct.

A.4.3.4 Closures should be constructed of compatible materials and provide equivalent or greater corrosion resistance and pressure rating equivalent to the duct.

A.4.4.1 “Inherently balanced” means the system has been designed using the velocity pressure method described in the ACGIH *Ventilation Manual for Design*.

A.4.4.4 Building components include walls, floors, or roofs.

A.4.4.5 For duct systems containing flammable or combustible materials, an evaluation is necessary to determine adequate exhaust stack termination design. Information on stack height can be found in the *ASHRAE Fundamentals Handbook*, the “Airflow Around Buildings” chapter, or the ACGIH publication, *Industrial Ventilation — A Manual of Recommended Practice for Design*.

A.4.4.7 For guidance on determining air volume and air velocity, refer to *Industrial Ventilation — A Manual of Recommended Practice*, published by the American Conference of Governmental Industrial Hygienists (ACGIH). [654: A.7.3.2.4]

A.4.4.8.2 When the materials cannot be enclosed at the source, a local exhaust ventilation system can be used. Because suction inlets have little directional effect beyond a few inches from the inlet, they should be located to sweep the air and minimize pockets that have no air movement. The location of the air makeup system ductwork and discharge points provides more uniform air movement.

When the materials are heavier than air, the inlets should be located near the floor. When the materials are lighter than air, the inlets should be located near the ceiling of the room or enclosure.

A.5.1.3 Properties that can affect the usability of plastic materials include, but are not limited to, the following:

- (1) Thermal effects such as softening
- (2) UV degradation
- (3) Brittleness
- (4) Static accumulation
- (5) Combustibility

A.7.1.4 Performance monitoring devices include, but are not limited to, pressure differential gauges and transmitters, motor ammeters, and flow gauges.

A.7.2 Combustible particulate solids are outside the scope of this document. If the system is handling a combustible particulate solid, refer to NFPA 654, *Standard for the Prevention of Fire and Dust Explosions from the Manufacturing, Processing, and Handling of Combustible Particulate Solids*.

A.7.2.1 The slope of the hopper bottom should address material properties such as material angle of repose, flow characteristics, moisture level, and material separator geometry. Proper slope angle will promote flow from the hopper by gravity alone.



Table A.4.1.5 Range of Minimum Duct Design Velocities

Nature of Contaminant	Examples	Design Velocity	
		m/min	ft/min
Vapors, gases, smoke Fumes	All vapors, gases, and smoke Welding	305–610* 610–763	1000–2000* 2000–2500
Very fine light dust	Cotton lint, wood flour, litho powder	763–915	2500–3000
Dry dusts and powders	Fine rubber dust, Bakelite® molding powder dust, jute lint, cotton dust, shavings (light), soap dust, leather shavings	915–1220	3000–4000
Average industrial dust	Grinding dust, buffing lint (dry), wool jute dust (shaker waste), coffee beans, shoe dust, granite dust, silica flour, general material handling, brick cutting, clay dust, foundry (general), limestone dust, packaging and weighing asbestos dust in textile industries	1068–1220	3500–4000
Heavy dusts	Sawdust (heavy and wet), metal turnings, foundry tumbling barrels and shake-out, sandblast dust, wood blocks, hog waste, brass turnings, cast-iron boring dust, lead dust	1220–1373	4000–4500
Heavy or moist dusts	Lead dusts with small chips, moist cement dust, asbestos chunks from transite pipe cutting machines, buffing lint (sticky), quick-lime dust	1373 and up	4500 and up

*Any desired velocity (economic optimum velocity usually within this range).

Source: ACGIH, *Industrial Ventilation — A Manual of Recommended Practice for Design*.

A.7.2.2 Different particulates have different settling velocities, particle sizes, and shapes, which necessitate specific collection and separation technologies. It is important for the separator to be designed for the particulate.

A.7.3.1 Examples include oil mist separators, electrostatic separators, scrubbers, high efficiency air filtration units (roll or cartridge media), cyclonic separators, and others.

A.8.2 See NFPA 77, *Recommended Practice on Static Electricity*; and the AIChE publications by Britton, *Avoiding Static Ignition Hazards in Chemical Operations*; and Pratt, *Electrostatic Ignitions of Fires and Explosions*.

A.8.2.2 Bonding minimizes the potential difference between conductive objects. Grounding minimizes the potential difference between objects and ground.

Using metal ducts with nonconductive plastic liners to convey mists and particulate solids can create the potential for electrostatic discharge sufficient to ignite conveyed materials or shock personnel.

A.8.2.3 PVC and other nonconductive duct materials can allow static accumulations and should be avoided. There are some conductive or static dissipative plastics that can be considered where corrosion resistance is required.

A.8.5.1 Magnets lose strength over time and should be replaced as necessary.

A.8.6 Transmission of power by direct drive should be used where possible in preference to belt or chain drives.

A.8.7 Consideration should be given to the potential for overheating caused by dust entry into bearings. Bearings should be located outside the exhaust stream where they are less exposed and more accessible for inspection and service. Where bearings are in contact with particulate solid streams, sealed or purged bearings are preferred.

A.9.1 For additional information on these topics, please see the following NFPA standards:

- (1) NFPA 11, *Standard for Low-, Medium-, and High-Expansion Foam*
- (2) NFPA 12, *Standard on Carbon Dioxide Extinguishing Systems*
- (3) NFPA 12A, *Standard on Halon 1301 Fire Extinguishing Systems*
- (4) NFPA 13, *Standard for the Installation of Sprinkler Systems*
- (5) NFPA 15, *Standard for Water Spray Fixed Systems for Fire Protection*
- (6) NFPA 17, *Standard for Dry Chemical Extinguishing Systems*
- (7) NFPA 17A, *Standard for Wet Chemical Extinguishing Systems*
- (8) NFPA 750, *Standard on Water Mist Fire Protection Systems*
- (9) NFPA 2001, *Standard on Clean Agent Fire Extinguishing Systems*

A.10.3 The required procedure and the minimum data necessary for a thorough initial ventilation test are outlined as follows:

- (1) Review the system specifications and drawings to determine the relative location and sizes of ducts, fittings, and associated system components.
- (2) Inspect the system to determine that its installation is in accordance with the specifications and drawings, and check items such as fan rotation, belt slippage, damper settings, and thermal overload sizes of starters.
- (3) Make a single-line drawing of the installed system and select and identify test locations.
- (4) Measure the air volume, fan static pressure, motor rpm and amperes, and the temperature of the air in the system.
- (5) Determine pressure drops across all components such as air-cleaning equipment.
- (6) Record the test data and design specifications.

- (7) Compare the test data with design specifications and determine if alterations or adjustments of the system are necessary to meet specifications.
- (8) If alterations or adjustments are made, retest the system and record the final test data, noting any physical changes that were made on the sketch.
- (9) Provide a permanent label indicating fan data such as static pressures, rpm, and motor current.
- (10) Lock all dampers and mark positions with permanent marker.
- (11) Retain test data sheets for the life of the system.

The field tests described in the preceding list pertain to air-handling characteristics only. At times it is necessary or desirable to conduct tests of the environment to determine if the system is providing the desired environmental control. In these cases, the services of a trained industrial hygienist would be required.

For some tests, moisture content of the air in the system or the ambient barometric pressure should be obtained.

All periodic measurements can also be made continuously by means of an operating console or other remote readout system.

The value of obtaining ventilation test data is noted in the following applications:

- (1) To record the initial performance of the system and determine if it is functioning in accordance with specifications
- (2) To determine the degree of compliance with applicable codes or trade association standards
- (3) To provide data upon which to base any necessary changes in the system
- (4) To obtain data to assist in the design of future systems
- (5) To determine whether the system has sufficient capacity for additional ductwork or other alterations
- (6) To obtain data through periodic checks to determine when maintenance or repairs are necessary

A.10.3.4 The following procedure should be followed for measurements needed to perform the periodic tests:

- (1) Refer to the initial test data sheet for test locations.
- (2) Inspect the system for physical damage (broken, corroded, collapsed duct, etc.) and correct operation of components (fan rotation, damper positions, air cleaner condition, etc.).
- (3) Measure static pressure at the same locations used in the initial test.
- (4) Compare measured static pressure recorded at the same locations used in the initial test to the initial pressure values.
- (5) Make and record any corrections required.
- (6) Recheck the system to verify performance if corrections have been made.

A.10.4 Inspection should include hoods; enclosures; ducts; duct connections; filtration system; blast gates locked in marked positions; access openings closed and secured; air-moving device inlets and outlets; air-moving device for belt tension, vibration, and lubrication; and termination and adjacent surfaces.

Annex B Informational References

B.1 Referenced Publications. The documents or portions thereof listed in this annex are referenced within the informational sections of this standard and are not part of the requirements of this document unless also listed in Chapter 2 for other reasons.

B.1.1 NFPA Publications. National Fire Protection Association, 1 Batterymarch Park, Quincy, MA 02169-7471.

NFPA 1, *Fire Code*, 2009 edition.

NFPA 11, *Standard for Low-, Medium-, and High-Expansion Foam*, 2010 edition.

NFPA 12, *Standard on Carbon Dioxide Extinguishing Systems*, 2008 edition.

NFPA 12A, *Standard on Halon 1301 Fire Extinguishing Systems*, 2009 edition.

NFPA 13, *Standard for the Installation of Sprinkler Systems*, 2010 edition.

NFPA 15, *Standard for Water Spray Fixed Systems for Fire Protection*, 2007 edition.

NFPA 17, *Standard for Dry Chemical Extinguishing Systems*, 2009 edition.

NFPA 17A, *Standard for Wet Chemical Extinguishing Systems*, 2009 edition.

NFPA 30, *Flammable and Combustible Liquids Code*, 2008 edition.

NFPA 30B, *Code for the Manufacture and Storage of Aerosol Products*, 2007 edition.

NFPA 32, *Standard for Drycleaning Plants*, 2007 edition.

NFPA 33, *Standard for Spray Application Using Flammable or Combustible Materials*, 2007 edition.

NFPA 34, *Standard for Dipping and Coating Processes Using Flammable or Combustible Liquids*, 2007 edition.

NFPA 35, *Standard for the Manufacture of Organic Coatings*, 2005 edition.

NFPA 36, *Standard for Solvent Extraction Plants*, 2009 edition.

NFPA 45, *Standard on Fire Protection for Laboratories Using Chemicals*, 2004 edition.

NFPA 61, *Standard for the Prevention of Fires and Dust Explosions in Agricultural and Food Processing Facilities*, 2008 edition.

NFPA 68, *Standard on Explosion Protection by Deflagration Venting*, 2007 edition.

NFPA 77, *Recommended Practice on Static Electricity*, 2007 edition.

NFPA 85, *Boiler and Combustion Systems Hazards Code*, 2007 edition.

NFPA 86, *Standard for Ovens and Furnaces*, 2007 edition.

NFPA 92A, *Standard for Smoke-Control Systems Utilizing Barriers and Pressure Differences*, 2009 edition.

NFPA 92B, *Standard for Smoke Management Systems in Malls, Atria, and Large Spaces*, 2009 edition.

NFPA 96, *Standard for Ventilation Control and Fire Protection of Commercial Cooking Operations*, 2008 edition.

NFPA 120, *Standard for Fire Prevention and Control in Coal Mines*, 2010 edition.

NFPA 204, *Standard for Smoke and Heat Venting*, 2007 edition.

NFPA 211, *Standard for Chimneys, Fireplaces, Vents, and Solid Fuel-Burning Appliances*, 2010 edition.

NFPA 303, *Fire Protection Standard for Marinas and Boatyards*, 2006 edition.

NFPA 318, *Standard for the Protection of Semiconductor Fabrication Facilities*, 2009 edition.

NFPA 409, *Standard on Aircraft Hangars*, 2004 edition.

NFPA 484, *Standard for Combustible Metals*, 2009 edition.

NFPA 654, *Standard for the Prevention of Fire and Dust Explosions from the Manufacturing, Processing, and Handling of Combustible Particulate Solids*, 2006 edition.

NFPA 655, *Standard for Prevention of Sulfur Fires and Explosions*, 2007 edition.

NFPA 664, *Standard for the Prevention of Fires and Explosions in Wood Processing and Woodworking Facilities*, 2007 edition.

NFPA 750, *Standard on Water Mist Fire Protection Systems*, 2010 edition.

NFPA 801, *Standard for Fire Protection for Facilities Handling Radioactive Materials*, 2008 edition.

NFPA 2001, *Standard on Clean Agent Fire Extinguishing Systems*, 2008 edition.

B.1.2 Other Publications.

B.1.2.1 ACGIH Publications. American Conference of Governmental Industrial Hygienists, 1330 Kemper Meadow Drive, Cincinnati, OH 45240-1634.

Industrial Ventilation — A Manual of Recommended Practice for Design, 26th edition, 2007.

B.1.2.2 AIChE Publications. American Institute of Chemical Engineers, Three Park Avenue, New York, NY 10016-5991.

Britton, L.G., *Avoiding Static Ignition Hazards in Chemical Operations*, 1999.

Pratt, T. H., *Electrostatic Ignitions of Fires and Explosions*, 1997.

B.1.2.3 ASHRAE Publications. American Society of Heating, Refrigerating, and Air Conditioning Engineers, Inc., 1791 Tullie Circle, N.E., Atlanta, GA 30329.

ASHRAE Fundamentals Handbook, 2005.

B.1.2.4 ASTM Publications. ASTM International, 100 Barr Harbor Drive, West Conshohocken, PA 19428-2959.

ASTM E 136, *Standard Test Method for Behavior of Materials in a Vertical Tube Furnace at 750°C*, 2004.

B.1.2.5 Other Publications.

B.2 Informational References. The following documents or portions thereof are listed here as informational resources only. They are not a part of the requirements of this document.

ACGIH, *Industrial Ventilation — A Manual of Recommended Practice for Operation and Maintenance*, 2007.

B.3 References for Extracts in Informational Sections. NFPA 68, *Standard on Explosion Protection by Deflagration Venting*, 2007 edition.

NFPA 329, *Recommended Practice for Handling Releases of Flammable and Combustible Liquids and Gases*, 2010 edition.

NFPA 654, *Standard for the Prevention of Fire and Dust Explosions from the Manufacturing, Processing, and Handling of Combustible Particulate Solids*, 2006 edition.

Index

Copyright © 2009 National Fire Protection Association. All Rights Reserved.

The copyright in this index is separate and distinct from the copyright in the document that it indexes. The licensing provisions set forth for the document are not applicable to this index. This index may not be reproduced in whole or in part by any means without the express written permission of NFPA.

-A-	
Administration	Chap. 1
Equivalency.....	1.4
Purpose.....	1.2
Retroactivity.....	1.3
Scope.....	1.1, A.1.1
Air-Material Separator (AMS)	
Definition.....	3.3.1, A.3.3.1
Air-Material Separators (Air Separation Devices)	Chap. 7
General Requirements.....	7.1
Access.....	7.1.8
Location.....	7.1.6
Manifolding of Ducts.....	7.1.9
Protection.....	7.1.7
Separators for Flammable Gases, Vapors, and Mists.....	7.3
Separators for Noncombustible Particulates.....	7.2, A.7.2
Air-Moving Device	
Definition.....	3.3.2, A.3.3.2
Air-Moving Devices	Chap. 6
Alignment.....	6.4
Clearance.....	6.3
Flammable or Combustible Materials.....	6.2
Flexible Connections.....	6.7
General.....	6.1
Location.....	6.6
Maintenance and Inspection.....	6.5
Approved	
Definition.....	3.2.1, A.3.2.1
Authority Having Jurisdiction (AHJ)	
Definition.....	3.2.2, A.3.2.2
-C-	
Corrosive Materials	Chap. 5
General.....	5.1
-D-	
Definitions	Chap. 3
Design and Construction	Chap. 4
Access.....	4.3
Location and Size.....	4.3.3
Design Requirements.....	4.4
Hoods.....	4.4.8
Duct Installation.....	4.6
Clearance Increases.....	4.6.3
Clearance Reduction Methods.....	4.6.4
General Requirements.....	4.6.1
Measuring Clearances.....	4.6.5
Systems Conveying Combustible Materials.....	4.6.2
Duct Material and Construction.....	4.2
Condensate.....	4.2.6
General Requirements.....	4.1
Magnetic Separations.....	4.1.7
System Plans.....	4.1.8, A.4.1.8
Hangers and Supports.....	4.5
Duct	
Definition.....	3.3.3
-E-	
Exhaust System	
Definition.....	3.3.4, A.3.3.4
Explanatory Material	Annex A
Explosion Hazard	
Definition.....	3.3.5, A.3.3.5
-F-	
Fire Barrier	
Definition.....	3.3.6
Fire Damper	
Definition.....	3.3.7
Fire Protection	Chap. 9
Drainage.....	9.2
General.....	9.1, A.9.1
Testing and Inspection.....	9.3
-I-	
Ignition Sources	Chap. 8
Bearings.....	8.7, A.8.7
Belt Drives.....	8.6, A.8.6
Electrical Equipment.....	8.1
Equipment.....	8.8
Manifolds.....	8.3
Open Flames and Sparks.....	8.4
Removal of Ferrous Materials.....	8.5
Static Electricity.....	8.2, A.8.2
Informational References	Annex B
-L-	
Labeled	
Definition.....	3.2.3
Limited Combustible	
Definition.....	3.3.8
Listed	
Definition.....	3.2.4, A.3.2.4
Lower Flammable Limit (LFL)	
Definition.....	3.3.9, A.3.3.9
-N-	
Noncombustible Material	
Definition.....	3.3.10, A.3.3.10
Noncombustible Particulate Solid	
Definition.....	3.3.11, A.3.3.11
-R-	
Referenced Publications	Chap. 2
General.....	2.1
NFPA Publications.....	2.2
Other Publications.....	2.3
References for Extracts in Mandatory Sections.....	2.4
-S-	
Shall	
Definition.....	3.2.5
-T-	
Testing and Maintenance	Chap. 10
Cleanliness.....	10.5
General.....	10.2
Maintenance Log.....	10.7
Maintenance Program.....	10.6
Retroactivity.....	10.1
System Inspection.....	10.4, A.10.4
System Test.....	10.3, A.10.3



Sequence of Events Leading to Issuance of an NFPA Committee Document

Step 1: Call for Proposals

- Proposed new Document or new edition of an existing Document is entered into one of two yearly revision cycles, and a Call for Proposals is published.

Step 2: Report on Proposals (ROP)

- Committee meets to act on Proposals, to develop its own Proposals, and to prepare its Report.
- Committee votes by written ballot on Proposals. If two-thirds approve, Report goes forward. Lacking two-thirds approval, Report returns to Committee.
- Report on Proposals (ROP) is published for public review and comment.

Step 3: Report on Comments (ROC)

- Committee meets to act on Public Comments to develop its own Comments, and to prepare its report.
- Committee votes by written ballot on Comments. If two-thirds approve, Report goes forward. Lacking two-thirds approval, Report returns to Committee.
- Report on Comments (ROC) is published for public review.

Step 4: Technical Report Session

- “Notices of intent to make a motion” are filed, are reviewed, and valid motions are certified for presentation at the Technical Report Session. (“Consent Documents” that have no certified motions bypass the Technical Report Session and proceed to the Standards Council for issuance.)
- NFPA membership meets each June at the Annual Meeting Technical Report Session and acts on Technical Committee Reports (ROP and ROC) for Documents with “certified amending motions.”
- Committee(s) vote on any amendments to Report approved at NFPA Annual Membership Meeting.

Step 5: Standards Council Issuance

- Notification of intent to file an appeal to the Standards Council on Association action must be filed within 20 days of the NFPA Annual Membership Meeting.
- Standards Council decides, based on all evidence, whether or not to issue Document or to take other action, including hearing any appeals.

Committee Membership Classifications

The following classifications apply to Technical Committee members and represent their principal interest in the activity of the committee.

- M *Manufacturer:* A representative of a maker or marketer of a product, assembly, or system, or portion thereof, that is affected by the standard.
- U *User:* A representative of an entity that is subject to the provisions of the standard or that voluntarily uses the standard.
- I/M *Installer/Maintainer:* A representative of an entity that is in the business of installing or maintaining a product, assembly, or system affected by the standard.
- L *Labor:* A labor representative or employee concerned with safety in the workplace.
- R/T *Applied Research/Testing Laboratory:* A representative of an independent testing laboratory or independent applied research organization that promulgates and/or enforces standards.
- E *Enforcing Authority:* A representative of an agency or an organization that promulgates and/or enforces standards.
- I *Insurance:* A representative of an insurance company, broker, agent, bureau, or inspection agency.
- C *Consumer:* A person who is, or represents, the ultimate purchaser of a product, system, or service affected by the standard, but who is not included in the *User* classification.
- SE *Special Expert:* A person not representing any of the previous classifications, but who has a special expertise in the scope of the standard or portion thereof.

NOTES;

1. “Standard” connotes code, standard, recommended practice, or guide.
2. A representative includes an employee.
3. While these classifications will be used by the Standards Council to achieve a balance for Technical Committees, the Standards Council may determine that new classifications of members or unique interests need representation in order to foster the best possible committee deliberations on any project. In this connection, the Standards Council may make appointments as it deems appropriate in the public interest, such as the classification of “Utilities” in the National Electrical Code Committee.
4. Representatives of subsidiaries of any group are generally considered to have the same classification as the parent organization.

NFPA Document Proposal Form

NOTE: All Proposals must be received by 5:00 pm EST/EDST on the published Proposal Closing Date.

For further information on the standards-making process, please contact the Codes and Standards Administration at 617-984-7249 or visit www.nfpa.org/codes.

For technical assistance, please call NFPA at 1-800-344-3555.

FOR OFFICE USE ONLY

Log #: _____

Date Rec'd: _____

Please indicate in which format you wish to receive your ROP/ROC electronic paper download
(Note: If choosing the download option, you must view the ROP/ROC from our website; no copy will be sent to you.)

Date April 1, 200X Name John J. Doe Tel. No. 716-555-1234

Company Air Canada Pilot's Association Email _____

Street Address 123 Summer Street Lane City Lewiston State NY Zip 14092

*****If you wish to receive a hard copy, a street address MUST be provided. Deliveries cannot be made to PO boxes.**

Please indicate organization represented (if any) _____

1. (a) NFPA Document Title National Fuel Gas Code NFPA No. & Year 54, 200X Edition

(b) Section/Paragraph 3.3

2. Proposal Recommends (check one): new text revised text deleted text

3. Proposal (include proposed new or revised wording, or identification of wording to be deleted): [Note: Proposed text should be in legislative format; i.e., use underscore to denote wording to be inserted (inserted wording) and strike-through to denote wording to be deleted (~~deleted wording~~).]

Revise definition of effective ground-fault current path to read:

3.3.78 Effective Ground-Fault Current Path. An intentionally constructed, permanent, low impedance electrically conductive path designed and intended to carry underground electric fault current ~~conditions~~ from the point of a ground fault on a wiring system to the electrical supply source.

4. Statement of Problem and Substantiation for Proposal: (Note: State the problem that would be resolved by your recommendation; give the specific reason for your Proposal, including copies of tests, research papers, fire experience, etc. If more than 200 words, it may be abstracted for publication.)

Change uses proper electrical terms.

5. Copyright Assignment

(a) I am the author of the text or other material (such as illustrations, graphs) proposed in the Proposal.

(b) Some or all of the text or other material proposed in this Proposal was not authored by me. Its source is as follows: (please identify which material and provide complete information on its source)

ABC Co.

I hereby grant and assign to the NFPA all and full rights in copyright in this Proposal and understand that I acquire no rights in any publication of NFPA in which this Proposal in this or another similar or analogous form is used. Except to the extent that I do not have authority to make an assignment in materials that I have identified in (b) above, I hereby warrant that I am the author of this Proposal and that I have full power and authority to enter into this assignment.

Signature (Required) _____

PLEASE USE SEPARATE FORM FOR EACH PROPOSAL

Mail to: Secretary, Standards Council · National Fire Protection Association
1 Batterymarch Park · Quincy, MA 02169-7471 OR
Fax to: (617) 770-3500 OR Email to: proposals_comments@nfpa.org

NFPA Document Proposal Form

NOTE: All Proposals must be received by 5:00 pm EST/EDST on the published Proposal Closing Date.

For further information on the standards-making process, please contact the Codes and Standards Administration at 617-984-7249 or visit www.nfpa.org/codes.

For technical assistance, please call NFPA at 1-800-344-3555.

FOR OFFICE USE ONLY

Log #: _____

Date Rec'd: _____

Please indicate in which format you wish to receive your ROP/ROC electronic paper download
(Note: If choosing the download option, you must view the ROP/ROC from our website; no copy will be sent to you.)

Date _____ Name _____ Tel. No. _____

Company _____ Email _____

Street Address _____ City _____ State _____ Zip _____

*****If you wish to receive a hard copy, a street address MUST be provided. Deliveries cannot be made to PO boxes.**

Please indicate organization represented (if any) _____

1. (a) NFPA Document Title _____ NFPA No. & Year _____

(b) Section/Paragraph _____

2. Proposal Recommends (check one): new text revised text deleted text

3. Proposal (include proposed new or revised wording, or identification of wording to be deleted): [Note: Proposed text should be in legislative format; i.e., use underscore to denote wording to be inserted (inserted wording) and strike-through to denote wording to be deleted (~~deleted wording~~).]

4. Statement of Problem and Substantiation for Proposal: (Note: State the problem that would be resolved by your recommendation; give the specific reason for your Proposal, including copies of tests, research papers, fire experience, etc. If more than 200 words, it may be abstracted for publication.)

5. Copyright Assignment

(a) I am the author of the text or other material (such as illustrations, graphs) proposed in the Proposal.

(b) Some or all of the text or other material proposed in this Proposal was not authored by me. Its source is as follows: (please identify which material and provide complete information on its source)

I hereby grant and assign to the NFPA all and full rights in copyright in this Proposal and understand that I acquire no rights in any publication of NFPA in which this Proposal in this or another similar or analogous form is used. Except to the extent that I do not have authority to make an assignment in materials that I have identified in (b) above, I hereby warrant that I am the author of this Proposal and that I have full power and authority to enter into this assignment.

Signature (Required) _____

PLEASE USE SEPARATE FORM FOR EACH PROPOSAL

Mail to: Secretary, Standards Council · National Fire Protection Association
1 Batterymarch Park · Quincy, MA 02169-7471 OR
Fax to: (617) 770-3500 OR Email to: proposals_comments@nfpa.org